

**LIAO CERAMICS BETWEEN 907 AD AND 1125 AD
IN NORTHERN CHINA**

Dissertation

zur Erlangung des akademischen Grades

Doktor der Philosophie

der Fakultät für Kulturwissenschaften

der Eberhard-Karls-Universität Tübingen

vorgelegt von Jing Lu

aus Liaoning , China

2008

Gedruckt mit Genehmigung der Fakultät
für Kulturwissenschaften der
Eberhard Karls Universität Tübingen

Hauptgutachter: Prof. Dr. Ernst Pernicka

Zweitgutachter: PD Dr. Mayke Wagner

Tag der mündlichen Prüfung: 09.Juli. 2008

Dekan: Prof. Dr. Thomas Schäfer

CONTENT

CONTENT.....	i
ACKNOWLEDGMENTS.....	xiii
TECHNICAL NOTES.....	xiv
LIST OF TABLES.....	xv
LIST OF TIMELINE TABLES.....	xviii
LIST OF MAPS.....	xix
LIST OF CHARTS.....	xx
LIST OF PLATES.....	xxi
LIST OF FIGURES.....	xxxvi
CHAPTER 1 INTRODUCTION.....	1
1.1 Introduction.....	1
1.1.1 The Scope of This Study.....	1
1.1.2 Methods.....	2
1.1.3 Sources of Study Materials.....	2
1.1.4 Problems and Objectives.....	3
1.2 Geographical framework.....	4
1.2.1 Geographical Borders.....	4
1.2.2 Administrative Division (Main Residents).....	5
1.3 Historical framework.....	6
1.3.1 History and Society.....	6
1.3.1.1 Historical Background.....	6
1.3.1.2 Political System.....	8
1.3.1.3 Social Economy.....	9
1.3.2 A Chronology of Liao Emperors.....	10
1.4 Previous studies.....	11

1.4.1 1920s-1940s.....	11
1.4.1.1 An Initial Definition of Liao Ceramics	11
1.4.1.2 Liao Kiln Sites.....	12
1.4.1.3 Liao City Sites and Tombs	13
1.4.1.4 Publications.....	13
1.4.2 1950s-1980s.....	14
1.4.2.1 Liao Kiln Sites.....	14
1.4.2.2 Liao Tombs and Other Sites.....	14
1.4.2.3 Publications.....	15
1.4.2.3.1 Chinese Publications.....	15
1.4.2.3.2 Japanese Publications	17
1.4.2.3.3 Publications in Western Languages	19
1.4.3 1990s-2000s.....	20
1.4.3.1 Liao Kiln Sites.....	20
1.4.3.2 Liao Tombs	20
1.4.3.3 Publications.....	21
1.4.3.3.1 Chinese Publications.....	21
1.4.3.3.1.1 Articles	21
1.4.3.3.1.2 Books.....	23
1.4.3.3.2 Japanese Publications	23
1.4.3.3.3 Publications in Western Languages	24
CHAPTER 2 THE ARCHAEOLOGICAL DISCOVERY OF LIAO CERAMICS	25
2.1 Finds from different kiln sites.....	25
2.1.1 The Gangwayaocun (GWYC) Kiln.....	26
2.1.1.1 General Introduction	26
2.1.1.2 Kilns and Technology.....	27

2.1.1.3 Varieties of Ceramics.....	28
2.2.1.3.1 White Stoneware and Porcelain	28
2.2.1.3.2 Three-color and Monochrome-glazed Earthenware.....	29
2.2.1.3.3 Black- (Brown-, and Teadust-green-) Glazed Stoneware.....	30
2.1.1.4 Inscriptions	30
2.1.1.5 Property.....	31
2.1.2 The Shangjing (SJY) Kiln	31
2.1.2.1 General Introduction	31
2.1.2.2 Kilns and Technology.....	32
2.1.2.3 Varieties of Ceramics.....	33
2.1.2.3.1 White Stoneware and Porcelain	33
2.1.2.3.2 Black-glazed Stoneware	34
2.1.2.3.3 Green-glazed Stoneware.....	34
2.1.2.3.4 Marbled Wares.....	34
2.1.2.4 Inscriptions	35
2.1.2.5 Property.....	35
2.1.3 The Nanshan (NSY) Kiln	35
2.1.3.1 General Introduction	35
2.1.3.2 Technology	36
2.1.3.3 Varieties of Ceramics.....	36
2.1.3.3.1 Three-color Lead-glazed Earthenware.....	36
2.1.3.3.2 Monochrome White-, Yellow-, and Green-glazed, Low-fired Earthenware	36
2.1.4 The Baiyingele (BYGL) Kiln	37
2.1.4.1 General Introduction	37
2.1.4.2 Kilns and Technology.....	37

2.1.4.3 Varieties of Ceramics.....	37
2.1.4.4 Property.....	38
2.1.5 The Hadayingge (HDYG) Kiln	38
2.1.6 The Xiaobeigou (XBG) Kiln	38
2.1.7 The Yaokengdi (YKD) Kiln	39
2.1.8 The Dongshabuertai (DSBET) Kiln.....	39
2.1.9 The Gangguantun (GGT) Kiln.....	39
2.1.9.1 General Introduction.....	39
2.1.9.2 Kilns and Technology.....	40
2.1.9.3 Varieties of Ceramics.....	40
2.1.9.4 Property.....	41
2.1.10 The Longquanwu (LQW) Kiln	41
2.1.10.1 General Introduction	41
2.1.10.2 Kilns and Technology	42
2.1.10.3 Varieties of Ceramics	42
2.1.10.3.1 White Stoneware and Porcelain.....	43
2.1.10.3.2 Three-color-glazed Earthenware	43
2.1.10.3.3 Black-glazed and Brown-glazed Wares	44
2.1.10.4 Inscriptions on Ceramics	44
2.1.10.5 Property	45
2.1.11 The Xiaoshuiyu (XSY) Kiln.....	45
2.1.12 The Cijiawu (CJW) Kiln	46
2.1.13 The Jiezhuang (JZY) Kiln	46
2.1.14 The Huairen (HRY) Kiln.....	47
2.1.15 The Datong (DTY) Kiln.....	48
2.1.16 The Longhua (LHY) Kiln.....	48

2.2 Finds from tombs, pagodas, and resident sites.....	49
2.2.1 Dated Tombs and Pagodas.....	49
2.2.3 Comparison of Dated and Undated Liao Tombs	108
CHAPTER 3 CERAMIC SHAPES	111
3.1 The bag-shaped pilgrim flask.....	111
3.1.1 Introduction.....	111
3.1.2 Typological Analysis.....	114
Group 1: Flasks With a Perforated Slab-handle.....	114
Group 2: Flasks With a Loop-handle	116
3.2 The Lugged Pilgrim Flask.....	119
3.2.1 Introduction.....	119
3.2.2 Typological Analysis.....	120
3.3 The Lugged Vase	121
3.3.1 Introduction.....	121
3.3.2 Typological Analysis.....	121
3.4 The Bowl-mouth Bottle.....	123
3.4.1 Introduction.....	123
3.4.2 Typological Analysis.....	123
3.5 The Carinate-shoulder Bottle.....	124
3.5.1 Introduction.....	124
3.5.2 Typological Analysis.....	124
3.6 The Long-Neck Vase.....	125
3.6.1 Introduction.....	125
3.6.2 Typological Analysis.....	125
3.7 The Phoenix-Head Vase	128
3.7.1 Introduction.....	128

3.7.2 Typological Analysis.....	129
3.8 The Spouted Ewer (Pitcher)	130
3.8.1 Introduction.....	130
3.8.2 Typological Analysis.....	131
3.9 The Chicken-leg vase	140
3.9.1 Introduction.....	140
3.9.2 Typological Analysis.....	141
3.10 Chinese-style Vases.....	142
3.11 The Jar	143
3.11.1 Introduction	143
3.11.2 Typological Analysis.....	144
3.12 The Basin.....	147
3.12.1 Introduction	147
3.12.2 Typological Analysis.....	148
3.13 The Spittoon.....	149
3.13.1 Introduction	149
3.13.2 Typological Analysis.....	149
3.14 The Saucer	151
3.14.1 Introduction	151
3.14.2 Typological Analysis.....	151
3.15 The Ring-foot Bowl	153
3.16 The Dragon-Handled Bowl	156
3.17 The Flat-Base Bowl	157
3.18 The Step-foot bowl.....	157
3.19 The Ring-foot Dish.....	158
3.20 The Flat-Base Dish.....	160

3.21	The Oblong-lobed dish.....	162
3.22	The Inkstone and brush-washer Combination.....	163
3.22.1	Introduction	163
3.22.2	Typological Analysis.....	164
3.23	The Ocarina (Holed Wind Instrument).....	165
3.23.1	Introduction	165
3.23.2	Typological Analysis.....	165
3.24	The Pillow	166
3.24.1	Introduction	166
3.24.2	Typological Analysis.....	166
3.25	The Box	167
3.25.1	Introduction	167
3.25.2	Typological Analysis.....	167
3.26	The Lamp And Incense Burner	168
3.27	The Sculpture	169
CHAPTER 4 DECORATION AND INSCRIPTION		170
4.1	Glazed Decoration	170
4.1.1	Monochrome-glazed Decoration	170
4.1.1.1.	White Glaze	170
4.1.1.2	Black (Brown, Teadust-green) Glaze.....	172
4.1.1.3	Yellow (Amber) Glaze.....	173
4.1.1.4	Green Glaze	173
4.1.2	Polychrome-glazed Decoration.....	174
4.1.2.1	Three-color Glazing.....	174
4.1.2.2	Double-color Glazing.....	175
4.2	Patterned Decoration	176

4.2.1 Motifs.....	176
4.2.1.1 The Peony Spray.....	176
4.2.1.2 The Peony Scroll	179
4.2.1.3 The Herbaceous Peony.....	180
4.2.1.4 Overlapping Lotus Petals	181
4.2.1.5 The Lotus Rosette and Related Ornaments	182
4.2.1.6 Scrolling Vines and Other Floral Ornaments	183
4.2.1.7 Plantain Leaves	184
4.2.1.8 The Stippling Plum Blossom.....	184
4.2.1.9 The Butterfly	184
4.2.1.10 Fish.....	185
4.2.1.11 The Dragon-fish.....	186
4.2.1.12 The Dragon and the Phoenix	187
4.2.1.13 The Monkey	188
4.2.1.14 The Human Figure	188
4.2.1.15 Others.....	189
4.2.2 Layout.....	189
4.2.3 Techniques.....	192
4.2.3.1 Incising & Carving.....	192
4.2.3.2 Molding.....	194
4.2.3.3 Applied Relief.....	195
4.2.3.4 Painting.....	196
4.3 Inscriptions.....	197
CHAPTER 5 MANUFACTURAL TECHNIQUE.....	201
5.1. The Forming and the raw materials of the bodies.....	201
5.1.1. Throwing.....	201

5.1.2. Molding	202
5.1.3. Other Methods of Forming.....	203
5.1.4. Different Varieties of the Bodies.....	203
5.1.5. Earthenware (or Tao 陶 in Chinese)	205
5.1.6. Stoneware and Porcelain (or Ci 瓷 in Chinese).....	208
5.2. Slipping.....	215
5.3. Glazing and the raw materials of glazes.....	216
5.3.1. White Stoneware and Porcelains	217
5.3.2. Lead Glazes	219
5.3.3. Borax Glazes.....	221
5.4. Loading (stacking) methods and kiln instruments	223
5.5. Firing and Kilns	226
5.5.1. The Firing Process	227
5.5.2. Fuel	229
5.5.3. Kiln.....	229
CHAPTER 6 A TENTATIVE CHRONOLOGICAL CLASSIFICATION	231
6.1 The Early Liao (907-947 and 947-969)	235
6.2 The Middle Liao (969-982 and 982-1031 and 1031-1055)	238
6.3 The Late Liao (1055-1125)	243
CHAPTER 7 CONCLUSION	249
GLOSSARY OF CHINESE CHARACTERS	256
Personal names.....	256
Place names.....	256
Dynasty names.....	260
Kilns and wares of China Proper	260
Inscriptions	260

Material and mineral names	260
Tribes and clans	260
Reign titles	260
Titles.....	260
Vessel names.....	261
Others	261
ABBREVIATIONS.....	262
Tombs	262
Kiln sites	264
Pagodas	264
APPENDICES.....	265
Table 24 Chronology of dynastic China	265
Table 25 Index of abbreviations of Liao tombs (a-z).....	265
Table 26 Index of abbreviations of Liao kiln sites (a-z).....	280
Table 27 List of unearthed objects and other collections: Bag-shaped pilgrim flask with perforated slab handle.....	282
Table 28 List of unearthed objects and other collections: Bag-shaped pilgrim flask with loop handle	292
Table 29 List of unearthed objects and other collections: lugged pilgrim flask	306
Table 30 List of unearthed objects and other collections: lugged vase	306
Table 31 List of unearthed objects and other collections: Bowl-mouth bottle	307
Table 32 List of unearthed objects and other collections: carinate-shoulder bottle	309
Table 33 List of unearthed objects and other collections: Long-neck vase	311
Table 34 List of unearthed objects and other collections: Phoenix-head vase.....	316
Table 35 List of unearthed objects and other collections: Spouted ewer (Pitcher).....	318
Table 36 List of unearthed objects and other collections: Chicken-leg vase.....	338
Table 37 List of unearthed objects and other collections: Chinese style vase.....	341

Table 38 List of unearthed objects and other collections: Jar	344
Table 39 List of unearthed objects and other collections: Basin.....	350
Table 40 List of unearthed objects and other collections: Spittoon.....	355
Table 41 List of unearthed objects and other collections: Saucer	359
Table 42 List of unearthed objects and other collections: Ring-foot bowl.....	362
Table 43 List of unearthed objects and other collections: Dragon-handled Bowl.....	377
Table 44 List of unearthed objects and other collections: Flat-base bowl.....	378
Table 45 List of unearthed objects and other collections: Step-foot bowl.....	379
Table 46 List of unearthed objects and other collections: Ring-foot dish.....	379
Table 47 List of unearthed objects and other collections: Flat-base dish	387
Table 48 List of unearthed objects and other collections: Oblong-lobed dish	392
Table 49 List of unearthed objects and other collections: Inkstone and Brush-washer	394
Table 50 List of unearthed objects and other collections: Ocarina	396
Table 51 List of unearthed objects and other collections: Pillow	399
Table 52 List of unearthed objects and other collections: Box	400
Table 53 List of unearthed objects and other collections: Lamp and Incense Burner	402
Table 54 List of unearthed objects and other collections: Sculpture	402
BIBLIOGRAPHY	408
MAPS.....	498
CATALOGUE.....	516
3.1 Bag-shaped pilgrim flask	516
3.1.1 Group 1.....	516
3.1.2 Group 2.....	539
3.2 Lugged pilgrim flask.....	579
3.3 Lugged vase.....	582
3.4 Bowl-mouth bottle	585

3.5 Carinate shoulder bottle	589
3.6 Long-neck vase	595
3.7 Phoenix-head vase.....	611
3.8 Spouted ewer.....	619
3.9 Chicken-leg vase.....	661
3.10 Chinese style vases	670
3.11 Jar.....	678
3.12 Basin	703
3.13 spittoon	718
3.14 saucer	728
3.15 Ring-foot bowl.....	738
3.16 Dragon-handled bowl.....	783
3.17 Flat-base bowl	785
3.18 Step-foot bowl	787
3.19 Ring-foot dish	789
3.20 Flat-base dish.....	810
3.21 Oblong-lobed dish.....	824
3.22 Inkstone and brush-washer	834
3.23 Ocarina	840
3.24 Pillow	847
3.25 Box.....	850
3.26 Lamp and Incense burner.....	855
3.27 Sculpture.....	858
PLATES AND FIGURES.....	872
CHRONOLOGICAL SEQUENCES OF LIAO CERAMICS	971
CHARTS.....	992

ACKNOWLEDGMENTS

First of all I would like to express my deep gratitude to Prof. Dr. Ernst Pernicka (Institute for Pre- and Protohistory and the Archaeology of the Middle ages, Eberhard-Karls-University of Tübingen) and PD. Dr. Mayke Wagner (Department of Eurasian Archaeology, German Archaeological Institute), my two supervisors, for the time and knowledge which they enriched this dissertation, and for all the help they have given to me during the course of my study. They introduced many experts and colleagues to me, which has helped me to build communication in this study field. Certainly the strong common sense of Prof. Pernicka and Dr. Wagner's crystal-clear logic contributed significantly to the final shape of this dissertation.

A huge thank you is also due to Prof. Guan Baocong (Shenyang, China), who led me into this research field and gave me great encouragement during the whole period of my study. His abundant collection of Liao ceramics enriched this dissertation.

I am greatly indebted to Prof. Dr. Manfred Korfmann, the former director of the Troia Project, my former supervisor, for the encouragement and for all the help he gave me during the first year of my doctoral education in Tübingen, who expanded my experience and view on archaeology. He will always be remembered in my whole life.

I am very grateful to the SHKP-Kwok's Foundation for the Scholarship, which provide the funding for my study.

I would like to thank all the staff of Troia-Project, Institute for Pre- and Protohistory and the Archaeology of the Middle ages, Eberhard-Karls-University of Tübingen, for their help with my work during the period I studied there, especially Mrs. Utta Gabriel and Mrs. Christel Bock. Their friendship and kindness will always be remembered.

In addition, a huge thank you is also due to Mrs. Anna Egger, the English editor, for her patient revising work on my draft and for her kindness.

I am grateful to many of my colleagues in the School of Archaeology and Museology, Peking University, especially Prof. Quan Kuishan (director of Ceramic Archaeology Institute).

Next I must thank Prof. Guo Zhizong, Prof. Li Hua, Prof. Zhang Yan, Prof. Peng Shanguo, Mr. Kazuo Toyomasu, Mr. Xu Daqing, Mrs. Chen Xiaoxue, Mr. Zhang Fan, for the support and advice on my study, and for all the help during my investigation in China.

Finally, I would like to thank my parents for their love and support. But my warmest thanks must go to my husband, Mr. Feng Wuyong. It would not have been possible for me to carry out the research for over three years abroad without his understanding and patience. I would not have been here without my husband's encouragement and support. His love is the driving force of my studying.

TECHNICAL NOTES

1. Chinese names and terms have been transliterated according to the Pinyin system. With the exception of some Romanized terms *Khitan*, *Qara-khitai*, *Jurchen*, *Manchurian etc.*, which are often used in Western literatures, these foreign names have been written in standard phonetic notations, according to their Chinese transcriptions.
2. Dates are generally given according to the Gregorian calendar. Chinese dates are given only when they have a specific importance to the study.
3. The term *Kiln* in this study have both narrow and genral meanings. The narrow meaning is an essential part of the manufacture of all ceramics, which, by definition, require heat treatment, often at high temperature. The general meaning is a kilns' area composed by many kiln sites which produce ceramics with the same style. For example, the GWYC kiln indicates many kiln sites around the Gangwayaocun village, the GWYC kiln site indicates the specific kiln site in Gangwayacun village.
4. The copyright of maps and pictures without reference belongs to the author.
5. The unit of ceramic's size in catalogue is cm.

LIST OF TABLES

Table 1 The Five Capitals of the Liao Dynasty.....	5
Table 2 Chronology of the Liao Dynasty (907-1125 AD).....	10
Table 3 Dated Liao Tombs and Discoveries of Liao Ceramics.....	49
Table 4 Undated Liao Tombs and Liao Ceramics Discovered Therein in Comparison with Dated Tombs	62
Table 5 Comparison of Dated and Undated Liao Tombs.....	108
Table 6 The chemical composition of raw materials of the bodies of Liao three-color lead-glazed ceramics	205
Table 7 The Chemical Composition of the bodies of Liao three-color lead-glazed ceramics....	206
Table 8 The sintering temperature and physical properties of the bodies of Liao earthenware	207
Table 9 The composition of Liao dynasty borax glazed earthenware bodies from LQW kiln site	207
Table 10 The sintering temperature and physical properties of Liao dynasty borax glazed earthenware bodies from LQW kiln site	208
Table 11 The composition of the raw materials in the bodies of Liao white-glazed stoneware and porcelains	209
Table 12 The Chemical composition of the bodies of Liao white-glazed stoneware and porcelains.....	211
Table 13 The sintering temperature and physical properties of the bodies of Liao white-glazed stoneware and porcelains.....	212
Table 14 The chemical composition of body of white-glazed porcelain from the LQW kiln site	213
Table 15 The sintering temperature and physical properties of Liao dynasty white porcelain bodies from the LQW kiln site	214
Table 16 The chemical composition of slips on Liao three-color lead-glazed ceramics from the GWYC kiln site	215
Table 17 The chemical composition of the glazes of Liao white-glazed stonewares and porcelains.....	217
Table 18 The chemical composition of Liao white-glazed porcelain of the LQW kiln sites	218

Table 19	The chemical composition of the glazes of Liao three-colored earthenware.....	220
Table 20	The spectrum analysis of Liao lead glazes of the GWT kiln site.....	220
Table 21	The chemical composition of the glazes on Liao borax-glazed earthenware from the LQW kiln site.....	222
Table 22	Different opinions on the chronological classification of Liao ceramics.....	231
Table 23	A tentative chronological classification of Liao ceramics.....	232
Table 24	Chronology of dynastic China.....	265
Table 25	Index of abbreviations of Liao tombs (a-z).....	265
Table 26	Index of abbreviations of Liao kiln sites (a-z).....	280
Table 27	List of unearthed objects and other collections: Bag-shaped pilgrim flask with perforated slab handle.....	282
Table 28	List of unearthed objects and other collections: Bag-shaped pilgrim flask with loop handle.....	292
Table 29	List of unearthed objects and other collections: lugged pilgrim flask.....	306
Table 30	List of unearthed objects and other collections: lugged vase.....	306
Table 31	List of unearthed objects and other collections: Bowl-mouth bottle.....	307
Table 32	List of unearthed objects and other collections: carinate-shoulder bottle.....	309
Table 33	List of unearthed objects and other collections: Long-neck vase.....	311
Table 34	List of unearthed objects and other collections: Phoenix-head vase.....	316
Table 35	List of unearthed objects and other collections: Spouted ewer (Pitcher).....	318
Table 36	List of unearthed objects and other collections: Chicken-leg vase.....	338
Table 37	List of unearthed objects and other collections: Chinese style vase.....	341
Table 38	List of unearthed objects and other collections: Jar.....	344
Table 39	List of unearthed objects and other collections: Basin.....	350
Table 40	List of unearthed objects and other collections: Spittoon.....	355
Table 41	List of unearthed objects and other collections: Saucer.....	359
Table 42	List of unearthed objects and other collections: Ring-foot bowl.....	362

Table 43 List of unearthed objects and other collections: Dragon-handled Bowl	377
Table 44 List of unearthed objects and other collections: Flat-base bowl	378
Table 45 List of unearthed objects and other collections: Step-foot bowl	379
Table 46 List of unearthed objects and other collections: Ring-foot dish	379
Table 47 List of unearthed objects and other collections: Flat-base dish.....	387
Table 48 List of unearthed objects and other collections: Oblong-lobed dish.....	392
Table 49 List of unearthed objects and other collections: Inkstone and Brush-washer	394
Table 50 List of unearthed objects and other collections: Ocarina	396
Table 51 List of unearthed objects and other collections: Pillow.....	399
Table 52 List of unearthed objects and other collections: Box.....	400
Table 53 List of unearthed objects and other collections: Lamp and Incense Burner	402
Table 54 List of unearthed objects and other collections: Sculpture.....	402

LIST OF TIMELINE TABLES

Timeline Table 1: Bag-shaped pilgrim flask (Group 1).....	972
Timeline Table 2: Bag-shaped pilgrim flask (Group 2).....	973
Timeline Table 3: Lugged pilgrim flask & Lugged vase	974
Timeline Table 4: Bowl-mouth bottle & Carinate shoulder bottle.....	975
Timeline Table 5: Long-neck vase	976
Timeline Table 6: Phoenix-head vase & Spouted ewer1.....	977
Timeline Table 7: Spouted ewer2.....	978
Timeline Table 8: Spouted ewer3.....	979
Timeline Table 9: Spouted ewer3 & Chicken-leg vase	980
Timeline Table 10: Chinese-style vase & Jar1.....	981
Timeline Table 11: Jar2.....	982
Timeline Table 12: Basin.....	983
Timeline Table 13: Spittoon.....	984
Timeline Table 14: Saucer	985
Timeline Table 15: Ring-foot bowl1	986
Timeline Table 16: Ring-foot bowl2.....	987
Timeline Table 17: Dragon-handled bowl , Flat-base bowl , Step-foot bowl , Flat-base dish1	988
Timeline Table 18: Ring-foot dish	989
Timeline Table 19: Oblong-lobed dish, Inkstone and brush-washer, Ocarina, Pillow.....	990
Timeline Table 20: Box & Lamp and Incense burner	991

LIST OF MAPS

Map 1: Liao empire, Ca. 1111 AD (google map, after Tan Qixiang, 1982)	499
Map 2: The administrative division of Liao (google map, after Tan Qixiang, 1982).....	500
Map 3: The reference location of Liao (Khitan), Western Liao (Qara Khitai) and Post-Western Liao (Kirman)	501
Map 4: Asia ca. 1142 AD : the Qara khitai (Western Liao) empire (after Biran 2005, 220, map3)	502
Map 5: Liao kiln sites.....	503
Map 6: GWYC kiln site.....	504
Map 7 ; Liao kiln sites around the Central Capital	505
Map 8: SJY kiln site.....	506
Map 9: Liao kiln sites around the Supreme Capital.....	507
Map 10: GGT kiln site	508
Map 11: Liao kiln sites around the Eastern Capital.....	509
Map 12: LQW kiln site.....	510
Map 13: Liao kiln sites around the Southern Capital.....	511
Map 14: JZY kiln site.....	512
Map 15: Liao kiln sites around the Western Capital	513
Map 16: Spread and distribution of the triangular kiln-setting support in China (after Kerr & Wood 2004, 341, fig. 86).....	514
Map 17: Spread of the step-setter technique (after Kerr & Wood 2004, 345, fig. 89).....	515

LIST OF CHARTS

Chart 1: Quantity analysis of different ceramic shapes of Liao dynasty.....	992
Chart 2: Quantity analysis of different ceramic shapes in Early Liao dynasty.....	993
Chart 3: Quantity analysis of different ceramic shapes in Middle Liao dynasty	994
Chart 4: Quantity analysis of different ceramic shapes in Late Liao dynasty.....	995
Chart 5: Case analysis on bag-shaped pilgrim flask	996
Chart 6: Quantity analysis of different glazes in Liao dynasty.....	997
Chart 7: Quantity analysis of different glazes in Early Liao dynasty.....	998
Chart 8: Quantity analysis of different glazes in Middle Liao dynasty	999
Chart 9: Quantity analysis of different glazes in late Liao dynasty	1000
Chart 10: Quantity comparison of unglazed and glazed Liao ceramics	1001
Chart 11: Quantity analysis of glaze varieties of Liao ceramics in the upper class of Khitan people	1002
Chart 12: Quantity analysis of glaze varieties of Liao ceramics in the middle class of Khitan people	1003
Chart 13: Quantity analysis of glaze varieties of Liao ceramics in the lower class of Khitan people	1004
Chart 14: Quantity analysis of glaze varieties of Liao ceramics in Han people.....	1005

LIST OF PLATES

Pl. 1: GWYC kiln-landscape.....	872
Pl. 2: Liao-type tile with molded animal mask	872
Pl. 3: GWYC-white stoneware.....	872
Pl. 4: GWYC-white stoneware.....	872
Pl. 5: GWYC-White porcelain	872
Pl. 6: GWYC-lead glazed earthenware.....	873
Pl. 7: GWYC-lead glazed earthenware.....	873
Pl. 8: GWYC- black (brown, tea-dust green glazed stoneeware	873
Pl. 9: GWYC- black (brown glazed stoneware).....	873
Pl. 10: GWYC- sgraffito black painted white stoneware	873
Pl. 11: GWYC- black painted white stoneware	873
Pl. 12: GWYC-sgraffito white stoneware.....	874
Pl. 13: GWYC- white stoneware with carved-lines decoration.....	874
Pl. 14: GWYC- kiln instruments.....	875
Pl. 15: GWYC- kiln instruments.....	875
Pl. 16: GWYC- kiln instruments.....	876
Pl. 17: GWYC- kiln instruments.....	876
Pl. 18: GWYC-Stacked white bowls with support-spurs left on the bottom.....	876
Pl. 19: GWYC- white bowl with spur-scars left on the bottom.....	876
Pl. 20: GWYC-Sticked white bowls' stackes	876
Pl. 21: GWYC- circle-shaped instruments.....	876
Pl. 22: GWYC-triangular shaped spurs.....	877
Pl. 23: GWYC-cylinder shaped supporting instruments	877

Pl. 24: GWYC-bowl	878
Pl. 25: : GWYC-ocarina.....	878
Pl. 26: GWYC-chessmen	878
Pl. 27: GWYC-vase	878
Pl. 28: GWYC-ewer	878
Pl. 29: GWYC-ewer	878
Pl. 30: GWYC-inkstone.....	878
Pl. 31: GWYC-dish.....	878
Pl. 32: GWYC-jar	878
Pl. 33: GWYC- vase	878
Pl. 34: GWYC-ewer	878
Pl. 35: GWYC—chicken leg vase	878
Pl. 36: GWYC-inkstone & brush-wash basin.....	878
Pl. 37: GWYC-incense burner & box.....	878
Pl. 38: GWYC- jar, vase & bowls.....	878
Pl. 39: GWYC-bowls	878
Pl. 40: GWYC-dishes & bag-shaped pilgrim flask	878
Pl. 41: GWYC- jar.....	878
Pl. 42: GWYC: outer-mold of ewer	879
Pl. 43: GWYC- inner-mold of dish.....	879
Pl. 44: GWYC- Guan and Xinguan mark on cylinder shaped firing instruments (Feng Yongqian 1984a, 386-92, pl.14:1,2, fig.2:1,3.)	879
Pl. 45: SJY- landscape	880
Pl. 46: SJY-excavation trenches in 1940 by Li Wenxin and Kuroda Genji	880
Pl. 47: SJY- saggar shards	880
Pl. 48: SJY- white porcelain shards.....	880

Pl. 49: SJY- white stoneware shards	881
Pl. 50: SJY-white porcelain shard with incised designs	881
Pl. 51: SJY- black glazed stoneware.....	881
Pl. 52: SJY- black glazed big jar shard.....	881
Pl. 53: SJY tea-dust green glazed stoneware	881
Pl. 54: SJY- marbled ware	882
Pl. 55: BYGL-landscape.....	882
Pl. 56: BYGL-brocken fire bricks with kiln sweat.....	882
Pl. 57: BYGL- cylinder shaped supporting instruments.....	882
Pl. 58: BYGL-shards spread around	882
Pl. 59: BYGL-bobbin shaped supporting insruments.....	882
Pl. 60: BYGL-shard of chicken-leg vase.....	883
Pl. 61: BYGL-black (tea-dust green) glazed stoneware.....	883
Pl. 62: BYGL-white stoneware.....	883
Pl. 63: HDYG-tea-dust green glazed camel.....	883
Pl. 64: GGT-landscape	883
Pl. 65: GGT- sticked bowls' stacks.....	883
Pl. 66: GGT-three spur-scars left on the dishes' bottoms.....	884
Pl. 67: GGT-unglazed circle and some with spur-scars left on the bowls' bottoms	884
Pl. 68: GGT- four spur-scars left on the bowls' bottoms	884
Pl. 69: GGT-supporting clay pads	884
Pl. 70: GGT- cylinder shaped support instruments	885
Pl. 71: GGT- mold instruments	885
Pl. 72: GGT-mold instument	885
Pl. 73: GGT-mold instrument	885
Pl. 74: GGT- firing and loading instruments	886

Pl. 75: GGT- bobbin shaped spacers.....	886
Pl. 76: three-foot shaped spacers.....	886
Pl. 77: GGT- strip shaped instruments.....	886
Pl. 78: GGT-triangular spacer	886
Pl. 79: GGT-cone shaped instruments.....	886
Pl. 80: GGT- white glazed bowl	886
Pl. 81: GGT- white glazed bowl	887
Pl. 82: GGT- white glazed bowl	887
Pl. 83: GGT- white glazed bowl	887
Pl. 84: GGT- white glazed bowl	887
Pl. 85: GGT- white glazed bowl	887
Pl. 86: GGT- white glazed bowl	887
Pl. 87: GGT- white glazed bowl	887
Pl. 88: GGT- white glazed bowl	887
Pl. 89: GGT- white glazed bowl	888
Pl. 90: GGT- white glazed dish.....	888
Pl. 91: GGT- white glazed dish.....	888
Pl. 92: GGT- white glazed dish.....	888
Pl. 93: GGT- white glazed ewer	888
Pl. 94: GGT- white glazed ewer	888
Pl. 95: GGT- white glazed incense burner.....	888
Pl. 96: GGT- white glazed incense burner.....	888
Pl. 97: GGT- white glazed jar	889
Pl. 98: GGT- white glazed jar	889
Pl. 99: GGT- white glazed jar	889
Pl. 100: GGT- white glazed jar	889

Pl. 101: GGT- white glazed jar	889
Pl. 102: GGT- white glazed vase.....	889
Pl. 103: GGT- white glazed vase.....	890
Pl. 104: GGT- white glazed vase.....	890
Pl. 105: GGT- white glazed basin	890
Pl. 106: GGT- white glazed basin	890
Pl. 107: GGT- white glazed covers	890
Pl. 108: GGT- white glazed covers	890
Pl. 109: GGT- white glazed figures.....	891
Pl. 110: GGT- white glazed figures.....	891
Pl. 111: GGT- white and black glazed animal toys	891
Pl. 112: GGT- white glazed animal toys	891
Pl. 113: GGT- white glazed taming-lion toys	891
Pl. 114: GGT- white glazed toy	891
Pl. 115: GGT- white glazed inkstone	892
Pl. 116: GGT- white glazed mini vases	892
Pl. 117: GGT- black glazed bowl	892
Pl. 118: GGT- black glazed bowl	892
Pl. 119: GGT- black glazed bowl	892
Pl. 120: GGT- black glazed bowl	892
Pl. 121: GGT- black glazed bowl	892
Pl. 122: GGT- black glazed bowl	892
Pl. 123: GGT- black glazed bowl	893
Pl. 124: GGT- black glazed bowl	893
Pl. 125: GGT- black glazed bowl	893
Pl. 126: GGT- black glazed dish	893

Pl. 127: GGT- black glazed step-bowl.....	893
Pl. 128: GGT- black glazed mini vase.....	893
Pl. 129: GGT- black glazed vases.....	894
Pl. 130: GGT- black glazed vase.....	894
Pl. 131: GGT- black glazed vase.....	894
Pl. 132: GGT- black glazed vase.....	894
Pl. 133: GGT- black glazed vase.....	894
Pl. 134: GGT- black glazed vase.....	894
Pl. 135: GGT- black glazed vase.....	895
Pl. 136: GGT- black glazed chicken-leg vase.....	895
Pl. 137: GGT- black glazed vase.....	895
Pl. 138: GGT- black glazed ewer.....	895
Pl. 139: GGT- black glazed ewer.....	895
Pl. 140: GGT- black glazed ewer.....	895
Pl. 141: GGT- black glazed ewer.....	896
Pl. 142: GGT- black glazed ewer.....	896
Pl. 143: GGT- black glazed jar.....	896
Pl. 144: GGT- black glazed jar.....	896
Pl. 145: GGT- black glazed jar.....	896
Pl. 146: GGT- tea-dust green glazed jar.....	896
Pl. 147: GGT- black glazed jar.....	897
Pl. 148: GGT- black glazed saucer.....	897
Pl. 149: GGT- inner black glazed jar.....	897
Pl. 150: GGT- black glazed jar.....	897
Pl. 151: GGT- black glazed basin.....	897
Pl. 152: GGT- black glazed ewer.....	897

Pl. 153: GGT- black glazed covers	898
Pl. 154: GGT- black glazed cover	898
Pl. 155: GGT- black glazed lamp	898
Pl. 156: GGT- black glazed lamp	898
Pl. 157: GGT- black glazed lamp	898
Pl. 158: GGT- black glazed lamp	898
Pl. 159: GGT- black glazed lamp	899
Pl. 160: GGT- black glazed lamp	899
Pl. 161: GGT- black glazed dog-shape toy.....	899
Pl. 162: GGT- black glazed horse-shape toy.....	899
Pl. 163: GGT- black glazed toys	899
Pl. 164: GGT- black glazed monkey-shape toy.....	899
Pl. 165: GGT- black glazed animal-head shaped ocarinas.....	900
Pl. 166: GGT- black glazed animal-head shaped ocarinas.....	900
Pl. 167: GGT- black glazed animal-head shaped ocarinas.....	900
Pl. 168: GGT- black glazed animal-head shaped ocarina.....	900
Pl. 169: GGT- black glazed shard of ewer with inner tube	900
Pl. 170: GGT- black glazed animal mask.....	900
Pl. 171: GGT- unglazed chessmen	900
Pl. 172: LQW-landscape (Beijingshi wenwu yanjiusuo 2002, pl.1)	901
Pl. 173: LQW- white stoneware shards	909
Pl. 174: LQW- white stonewares (Beijingshi wenwu yanjiusuo 2002, pl.5)	909
Pl. 175: LQW- white porcelain shards.....	909
Pl. 176: LQW- white porcelain bowl	909
Pl. 177: LQW- white porcelain dish.....	909

Pl. 178: LQW- green and yellow glazed earthenwares (Beijingshi wenwu yanjiusuo 2002, pl.3)	910
Pl. 179: LQW- three color glazed earthenware buddha and unglazed buddha biscuit (Beijingshi wenwu yanjiusuo 2002, pl.6,7)	910
Pl. 180: LQW- three-color glazed tile with Shouchangwu inscription (Beijingshi wenwu yanjiusuo 2002, pl.8:1,2)	910
Pl. 181: XSY-firing instruments (Zhao guanglin 1984a, 410, fig.3)	910
Pl. 182: CJW-firing instruments (Zhao Guanglin 1984a, 412, fig.6)	910
Pl. 183: JZY- landscape	910
Pl. 184: JZY- white porcelain square dish	911
Pl. 185: JZY- white stoneware shards	911
Pl. 186: JZY- white porcelain spitton	911
Pl. 187: JZY-brown glazed jar shard	912
Pl. 188: JZY- white stoneware bowl shard	912
Pl. 189: JZY- white stoneware jar	912
Pl. 190: JZY- brown glazed jar	912
Pl. 191: JZY- white glazed stoneware shard with carved design	913
Pl. 192: JZY- White stoneware shards	913
Pl. 193: JZY- white and black glazed shards	914
Pl. 194: JZY- white shards	914
Pl. 195: JZY- white porcelain shard with impressed floral design	915
Pl. 196: JZY- black and tea-dust green glazed chicken-leg vase shards	915
Pl. 197: JZY- green and black glazed shards	915
Pl. 198: JZY- black glazed stoneware bowl shard	915
Pl. 199: JZY- black glazed stoneware shard	916
Pl. 200: JZY- black glazed shards with carved floral designs	916
Pl. 201: JZY- black stoneware shard with impressed design	917

Pl. 202: JZY- brown glazed stoneware shard	917
Pl. 203: JZY- black glazed stoneware shards.....	917
Pl. 204: JZY- black galzed stoneware shard	917
Pl. 205: JZY- white bowl with incised designs	918
Pl. 206: JZY- white vase.....	918
Pl. 207: JZY- white ewer.....	918
Pl. 208: JZY- white jar.....	918
Pl. 209: JZY- white porcelain bowl with cover.....	918
Pl. 210: JZY- black glazed bowl	918
Pl. 211: JZY- black galzed jar with carved designs.....	918
Pl. 212: JZY- bobbin shaped supporting instrument.....	919
Pl. 213: JZY- saggar fragments	919
Pl. 214: XYY (Dadong kiln site)- white stoneware shards.....	920
Pl. 215: XYY (Dadong kiln site)- white stoneware shards.....	920
Pl. 216: XYY (Dadong kiln site)- white stoneware shards.....	920
Pl. 217: XYY (Dadong kiln site)- outer black and inner white stoneware shards.....	920
Pl. 218: XYY (Dadong kiln site)- white porcelain shard.....	921
Pl. 219: XYY (Dadong kiln site)- tea-dust green glazed shard.....	921
Pl. 220: XYY (Dadong kiln site)- black and brown glazed shards.....	921
Pl. 221: XYY (Dadong kiln site)- firing instruments	921
Pl. 222: EMK (Zhangwagou kiln site)- tea-dust green glazed bowl shard	922
Pl. 223: EMK (Zhangwagou kiln site)- brown and tea-dust green glazed stoneware shards ...	922
Pl. 224: EMK (Zhangwagou kiln site)- black and brown glazed stoneware shards	923
Pl. 225: EMK (Zhangwagou kiln site)- tea-dust green glazed bowl shard	923
Pl. 226: EMK (Zhangwagou kiln site)- tea-dust green glazed bowl shard	924

Pl. 227: EMK (Zhangwagou kiln site)- black and tea-dust green glazed stoneware shards with incised designs	924
Pl. 228: EMK (Zhangwagou kiln site)- outer black and inner white glazed shard	924
Pl. 229: EMK (Zhangwagou kiln site)- black glazed stoneware shards.....	924
Pl. 230: EMK (Zhangwagou kiln site)- black glazed stoneware	925
Pl. 231: EMK (Zhangwagou kiln site)- outer black and inner white glazed shard	925
Pl. 232: EMK (Zhangwagou kiln site)- black glazed bowl shard	925
Pl. 233: EMK (Zhangwagou kiln site)- tea-dust green glazed vase shard	925
Pl. 234: EMK (Zhangwagou kiln site)- tea-dust green glazed chicken-leg vase bottom	925
Pl. 235: EMK (Zhangwagou kiln site)- black glazed lamp shard	925
Pl. 236: EMK (Zhangwagou kiln site)- black glazed chicken-leg vase bottom	926
Pl. 237: EMK (Zhangwagou kiln site)- black glazed shard with incised design.....	926
Pl. 238: EMK (Zhangwagou kiln site)- black glazed shards	926
Pl. 239: EMK (Zhangwagou kiln site)- black galzed stoneware shard with incised design.....	926
Pl. 240: EMK (Zhangwagou kiln site)- white bowl with incised design.....	926
Pl. 241: EMK (Zhangwagou kiln site)- white stoneware bowl.....	926
Pl. 242: EMK (Zhangwagou kiln site)- bobbin shaped supporting instrument	927
Pl. 243: EMK (Zhangwagou kiln site)- round supporting pad	927
Pl. 244: EMK (Zhangwagou kiln site)- mold instrument.....	927
Pl. 245: EMK (Zhangwagou kiln site)- bobbin shaped supporting instrument	927
Pl. 246: EMK (Zhangwagou kiln site)- supporting spurs	927
Pl. 247: EMK (Zhangwagou kiln site)- cylinder shaped supporting instrument.....	927
Pl. 248: Plant and flower pot painted on a stone coffin of a tomb at Erbadi, Keshiketeng Banner, Inner Mongolia (Xiang Chunsong 1984, pls. 10, 72)	928
Pl. 249: Peony spray-Mold for impressing decoration on the interior of lobed dishes. Excavated from GWYC kiln site. (Feng Yongqian 1984a, 386-392, fig.3)	928
Pl. 250: Peony spray on phoenix-head vase (detail from Cat. 354).....	928

Pl. 251: Peony spray on phoenix-head vase (detail from Cat. 356).....	929
Pl. 252: Peony spray on carinate shoulder bottle (detail from Cat. 291).....	929
Pl. 253: Peony spray on long-neck vase (detail from Cat. 342).....	929
Pl. 254: Peony spray on long-neck vase (detail from Cat. 314).....	929
Pl. 255: Peony spray on long-neck vase (detail from Cat. 332).....	929
Pl. 256: Peony spray on basin (detail from Cat. 711).....	929
Pl. 257: Peony spray on bag-shaped pilgrim flask (detail from Cat. 163).....	930
Pl. 258: Peony spray on bag-shaped pilgrim flask (detail from Cat. 164).....	930
Pl. 259: Peony spray on bag-shaped pilgrim flask (detail from Cat. 162).....	930
Pl. 260: Peony spray on bag-shaped pilgrim flask (detail from Cat. 216).....	930
Pl. 261: Peony spray with two leaves extending horizontally outwards on round dish (detail from Cat. 1055).....	931
Pl. 262: Peony spray with two leaves extending horizontally outwards on round dish (detail from Cat. 1057).....	931
Pl. 263: Peony spray on the shoulder of jar (detail from Cat. 614).....	932
Pl. 264: Peony spray on jar (detail from Cat. 664).....	932
Pl. 265: Peony scroll on long-neck vase (detail from Cat. 304).....	932
Pl. 266: Peony scroll on long-neck vase (detail from Cat. 303).....	933
Pl. 267: Peony scroll on big jar (detail from Cat. 614).....	933
Pl. 268: Peony scroll on big jar (detail from Cat. 615).....	933
Pl. 269: Peony scroll on big jar (detail from Cat. 611).....	933
Pl. 270: Peony scroll on big jar (detail from Cat. 673).....	933
Pl. 271: Peony scroll on big jar (detail from Cat. 676).....	933
Pl. 272: Peony scroll on big jar (detail from Cat. 677).....	933
Pl. 273: Peony scroll on big jar (detail from Cat. 679).....	933
Pl. 274: Peony scroll on big jar (detail from Cat. 621).....	934
Pl. 275: Peony scroll on vase (detail from Cat. 570).....	934

Pl. 276: Peony scroll on vase (detail from Cat. 571)	934
Pl. 277: Peony scroll on vase (detail from Cat. 572)	934
Pl. 278: Peony scroll on vase (detail from Cat. 369)	934
Pl. 279: Peony scroll on vase (detail from Cat. 370)	934
Pl. 280: Peony scroll on ewer (detail from Cat. 491)	935
Pl. 281: Peony scroll on inkstone (detail from Cat. 1204)	935
Pl. 282: Herbaceous peony on basin (description see Cat. 742)	935
Pl. 283: Herbaceous peony on basin (description see Cat. 741)	935
Pl. 284: Herbaceous peony on long-neck vase (detail from Cat. 312)	936
Pl. 285: Herbaceous peony on basin (description see Cat. 313)	936
Pl. 286: Overlapping Lotus petals on bowl (description see Cat. 953)	937
Pl. 287: Overlapping Lotus petals on bowl (description see Cat. 955)	937
Pl. 288: Overlapping Lotus petals on ewer (description see Cat. 395)	938
Pl. 289: Overlapping Lotus petals on vase (detail from Cat. 570)	938
Pl. 290: Overlapping Lotus petals on vase (detail from Cat. 571)	938
Pl. 291: Lotus rosette on Liao ceramic basin (detail from Cat. 716)	940
Pl. 292: S-curved petals on the shoulder of long-neck vase (detail from Cat. 304)	942
Pl. 293: S-curved petals on the shoulder of phoenix-head vase (detail from Cat. 356)	942
Pl. 294: Scrolling vines on bag-shaped pilgrim flask (detail from Cat. 72)	943
Pl. 295: Leaf design on Type B of Group2 bag-shaped pilgrim flask (detail from Cat. 219)	943
Pl. 296: Leaf scroll on handle of ewer (detail from Cat. 465)	945
Pl. 297: Stippling plum blossom on jar (detail from Cat. 610)	947
Pl. 298: Stippling plum blossom on jar (detail from Cat. 672)	947
Pl. 299: Stippling plum blossom on bowl (detail from Cat. 997)	947
Pl. 300: : Butterfly on Tang silver box , Tang dynasty. (detail from Cat. 1160)	948
Pl. 301: Butterfly on ewer (detail from Cat. 491)	949

Pl. 302: Butterfly on ewer (detail from Cat. 489).....	949
Pl. 303: Butterfly on ewer (detail from Cat. 425).....	949
Pl. 304 : Fish on oblong lobed dish, Tang dynasty. (description see Cat. 1167)	950
Pl. 305: Fish on basin (description see Cat. 732)	950
Pl. 306: Fish on basin (description see Cat. 735)	950
Pl. 307: dragon-fish formed Greeware ewer unearthed from SQ1 tomb, Beipiao, Liaoning. Made at a Northern Song kiln. 10th-early 11th Century. L:14cm (Xu Yulin 1971, 44-51)	952
Pl. 308: Dragon-fish formed ewer (description see Cat. 507).....	952
Pl. 309: Dragon-fish formed ewer (description see Cat. 523).....	952
Pl. 310: Dragon-fish formed ewer (description see Cat. 505).....	953
Pl. 311: Dragon-fish formed ewer (description see Cat. 504).....	953
Pl. 312: Dragon-fish formed ewer (description see Cat. 503).....	953
Pl. 313: Phoenix on ewer (detail from Cat. 425).....	954
Pl. 314: Dragon on ewer (detail from Cat. 428)	954
Pl. 315: Dragon on ewer (detail from Cat. 429)	954
Pl. 316: Dragon on bag-shaped pilgrim flask (detail from Cat. 86).....	954
Pl. 317: Monkey on bag-shaped pilgrim flask (detail from Cat. 54)	955
Pl. 318: Monkey on bag-shaped pilgrim flask (detail from Cat. 59)	955
Pl. 319: Monkey on bag-shaped pilgrim flask (detail from Cat. 87)	955
Pl. 320: Human tamping lion motif on brush-washer (detail from Cat. 1213).....	956
Pl. 321: Human motif on jar (detail from Cat. 687)	956
Pl. 322: Human figure (description see Cat. 1312).....	956
Pl. 323: Human figure (description see Cat. 1313).....	956
Pl. 324: Human figure (description see Cat. 1314).....	957
Pl. 325: Human figure (description see Cat. 1315).....	957
Pl. 326: Human figure (description see Cat. 1316).....	957

Pl. 327: Human figure (description see Cat. 1317).....	957
Pl. 328: Human figure (description see Cat. 1318).....	957
Pl. 329: Human figure (description see Cat. 1320).....	957
Pl. 330: Human figure (description see Cat. 1321).....	958
Pl. 331: Human figure (description see Cat. 1322).....	958
Pl. 332: Firing-ball motif on three-colored tile from LQW kiln (Beijingshi wenwu yanjiusuo 2002).....	958
Pl. 333: Layout of the designs on outer wall of three-colored inkstone (description see Cat. 1204).....	962
Pl. 334: Layout of the designs on outer wall of three-colored inkstone (description see Cat. 1210).....	962
Pl. 335: Layout of the designs on outer wall of three-colored inkstone (description see Cat. 1214).....	962
Pl. 336: Layout of the designs on over surface of three-colored inkstone (description see Cat. 1210).....	963
Pl. 337: Layout of the designs on over surface of three-colored inkstone (description see Cat. 1214).....	963
Pl. 338: Layout of the designs on outer wall of three-colored box (description see Cat. 1274)	963
Pl. 339: Layout of the designs on outer wall of yellow glazed box (description see Cat. 1273)	963
Pl. 340: Layout of the designs on outer wall of three-colored box (description see Cat. 1277)	963
Pl. 341: Layout of the designs on outer wall of three-colored box (description see Cat. 1278)	964
Pl. 342: Inscription by ink on jar bottom (detail from Cat. 681).....	964
Pl. 343: Inscription incised on shoulder of chicken-leg vase (Lu Jing 2003, 335, pl. 4-448)	964
Pl. 344: Inscription incised on shoulder of chicken-leg vase (detail from Cat. 551)	964
Pl. 345: Inscription incised on shoulder of chicken-leg vase (detail from Cat. 554)	964
Pl. 346: Inscription incised on shoulder of chicken-leg vase (detail from Cat. 568)	964
Pl. 347: Inscription incised on shoulder of chicken-leg vase (Lu Jing 2003, 335, pl. 4-445)	965

Pl. 348: Inscription incised on shoulder of chicken-leg vase (Lu Jing 2003, 335, pl. 4-446)	965
Pl. 349: Inscription incised on three-colored tile (Beijingshi wenwu yanjiusuo 2002).....	965
Pl. 350: Inscription incised on base of basin (Lu Jing 2003, 336, pl. 4-459).....	965
Pl. 351: Inscription incised on base of vase (detail from Cat. 582).....	965
Pl. 352: Guan mark on firing instrument from GWYC kiln	966
Pl. 353: Xinguan mark on firing instrument from GWYC kiln	966
Pl. 354: Guan mark on bowl (detail from Cat. 884).....	967
Pl. 355: Guan mark on bowl (detail from Cat. 972).....	967
Pl. 356: Guan mark on lugged vase (detail from Cat. 245)	967
Pl. 357: Guan mark on long neck vase (detail from Cat. 293)	967
Pl. 358: Guan mark on bowl (detail from Cat. 407).....	967
Pl. 359: Guan mark on bowl (detail from Cat. 896).....	967
Pl. 360: Mural painting of east wall of the rear chanber of Tomb M10, Xuanhua, Hebei Province. (after Hebeisheng wenwu yanjiusuo 2001, pl. 18.)	969
Pl. 361: Stone panel with relif decoration, from the tomb of Mme Xiao and her husband, Yelu Woli, at Yangjiayingzi in Balin Left Banner (after Shen Hsueh-man 2006, 213, cat. 50b)	969
Pl. 362: Mural painting of south wall of the rear chanber of ZSQ tomb, at Xuanhua, Hebei Province. (after Hebeisheng wenwu yanjiusuo 2001)	970
Pl. 363: Gilded silver boxes, from the relic deposit (dated 974) underneath Famen Pagoda in Fufeng, Shaanxi Province (after after Shen Hsueh-man 2006, 348, Fig. 118)	970

LIST OF FIGURES

Fig. 1: GWYC-kiln (Mok 1985, fig.13)	874
Fig. 2: GWYC-kilns (Peng Shanguo 2003,35, fig.2-1)	874
Fig. 3: GWYC- kiln instruments (after Peng Shanguo 2003, 36-36, fig. 2-2, 2-3, changed).....	875
Fig. 4: GWYC-triangular shaped spurs and the loading method	877
Fig. 5: GWYC- bobbin shaped supporting instrument and usage	877
Fig. 6: GWYC- decorations (Jia Zhoujie 1973, 241-3,fig.2)	879
Fig. 7: SJY- saggars.....	880
Fig. 8: SJY-supporting spurs	880
Fig. 9: SJY- vessel shapes	881
Fig. 10: LQW- workshop 2-4 (Beijingshi wenwu yanjiusuo 2002, 54, fig. 11)	901
Fig. 11: LQW- workshop 1 (Beijingshi wenwu yanjiusuo 2002, 63, fig.14)	902
Fig. 12: LQW- kiln 13 & recovery (Beijingshi wenwu yanjiusuo 2002, 43, 468, fig.6, 148)	903
Fig. 13: LQW- kiln 10 & recovery (Beijingshi wenwu yanjiusuo 2002, 45, 467 fig.7, 147)	904
Fig. 14: LQW- kiln 10 & recovery (Beijingshi wenwu yanjiusuo 2002, 48, 469, fig.8, 149)	905
Fig. 15: LQW- kiln 9-11 (Beijingshi wenwu yanjiusuo 2002, 51, fig.9.).....	906
Fig. 16: LQW- saggars (Beijingshi wenwu yanjiusuo 2002, 112, 115, fig.33, fig.34, changed).906	
Fig. 17: LQW- firing instruments (Beijingshi wenwu yanjiusuo 2002, 117, fig.35, changed) ..906	
Fig. 18: LQW-inner molds of square dish and round dish (Beijingshi wenwu yanjiusuo 2002, 182, fig.59:1)	906
Fig. 19: LQW- loading methods (Beijingshi wenwu yanjiusuo 2002, 408, fig.143)	907
Fig. 20: LQW- loading methods (Beijingshi wenwu yanjiusuo 2002, 409, fig.144)	907
Fig. 21: : LQW- vessel shapes	908
Fig. 22: JZY- vessel shapes (Feng Xianming 1984, 417, fig.3)	911
Fig. 23: Peony spray on oblong lobed dish (detail from Cat. 1177).....	927

Fig. 24: Peony spray on oblong lobed dish (detail from Cat. 1181).....	927
Fig. 25: Peony spray on oblong lobed dish (detail from Cat. 1182).....	928
Fig. 26: Peony spray on silver ewer and bowl from a store of silver found near Balin Right Banner, Inner Mongolia, c. 1100. (Ba Youwen & Cheng Shun 1980, 45-51)	928
Fig. 27: Peony spray on inkstone (detail from Cat. 1206)	928
Fig. 28: Peony spray on the interior of dish (detail from Cat. 1029).....	930
Fig. 29: Peony spray on the interior of dish (detail from Cat. 1072).....	930
Fig. 30: Peony spray on the interior of dish (Zhu Zifang & Xu Ji 1983 168-95, fig. 20:2)	931
Fig. 31: Peony spray with two leaves extending horizontally outwards on round dish (detail from Cat. 1037)	931
Fig. 32: Peony spray with two leaves extending horizontally outwards on inkstone (detail from Cat. 1206)	931
Fig. 33: Flower spray with two leaves extending horizontally outwards on inkstone (detail from Cat. 1206)	931
Fig. 34: Flower spray with four leaves pointing outwards on square dish (detail from Cat. 1148)	932
Fig. 35 Flower spray with two leaves extending horizontally outwards on brush-washer (detail from Cat. 1203)	932
Fig. 36: Peony scroll on long-neck vase (detail from Cat. 301)	932
Fig. 37: Detail from an epitaph of ZKY tomb (Deng Baoxue 1983, 30-38, fig. 15).....	935
Fig. 38: Detail from a wood coffin of JFYZ tomb (Xiang Chunsong 1984, pl.76).....	935
Fig. 39: Peony scroll on the interior wall of bowl (detail from Cat. 892)	935
Fig. 40: : Peony scroll on the interior wall of bowl (detail from Cat. 854).....	935
Fig. 41: Overlapping Lotus petals on jar (description see Cat. 653).....	936
Fig. 42: Overlapping Lotus petals on jar (description see Cat. 654).....	936
Fig. 43: Overlapping Lotus petals on jar (description see Cat. 655).....	936
Fig. 44: Overlapping Lotus petals on jar (description see Cat. 661).....	936
Fig. 45: Overlapping Lotus petals on bowl (description see Cat. 842).....	936
Fig. 46: Overlapping Lotus petals on bowl (description see Cat. 952).....	936

Fig. 47: Overlapping Lotus petals on bowl (description see Cat. 957).....	937
Fig. 48: Overlapping Lotus petals on phoenix-head vase (description see Cat. 351).....	937
Fig. 49: Overlapping Lotus petals on long-neck vase (detail from Cat. 298)	937
Fig. 50: Overlapping Lotus petals on ewer (description see Cat. 452).....	937
Fig. 51: Overlapping Lotus petals on ewer (description see Cat. 393).....	938
Fig. 52: Overlapping Lotus petals on ewer (description see Cat. 396).....	938
Fig. 53: Overlapping Lotus petals on ewer (description see Cat. 430).....	938
Fig. 54: Overlapping Lotus petals on ewer (description see Cat. 442).....	938
Fig. 55: Overlapping Lotus petals on ewer (description see Cat. 405).....	938
Fig. 56 : Lotus rosette-detail from a silver cup with handle. Tang dynasty. (Gyllensvard 1957, fig. 87:e)	939
Fig. 57: Lotus rosette-detail from a three-colored tray. Tang dynasty. (Gyllensvard 1957, fig. 87:i).....	939
Fig. 58: Lotus rosette-detail from a stone stele of a Liao tomb at Xigushan, Liaoning (Yan Wanzhang 1957, 69-82. fig.1).....	939
Fig. 59: Lotus rosette-detail from a wall painting of a Liao tomb at Xuanhua, Hebei. (Hebeisheng wenwu guanlichu et al. 1935, 31-39, pl.1)	939
Fig. 60: Lotus rosette on Liao ceramic basin (detail from Cat. 176).....	939
Fig. 61: Lotus rosette on Liao ceramic basin (detail from Cat. 715).....	939
Fig. 62: Lotus rosettes on oblong lobed dish (detail from Cat. 1191).....	940
Fig. 63: Lotus rosettes on oblong lobed dish (detail from Cat. 1200).....	940
Fig. 64: Lotus rosettes on oblong lobed dish (detail from Cat. 1184).....	940
Fig. 65: Metallic origin of lotus rosettes ornament on Tang gold or silver wares (Qi Dongfang 1999).....	940
Fig. 66: Lotus rosettes on silver oblong lobed dish (detail from Cat. 1172)	940
Fig. 67: Lotus rosettes on flat-base dish (detail from Cat. 1113).....	941
Fig. 68: Lotus rosette on flat-base dish (detail from Cat. 1112).....	941
Fig. 69: Lotus rosette on flat-base dish (detail from Cat. 1114).....	941

Fig. 70: S-curved petals on ring-foot dish (detail from Cat. 1050).....	941
Fig. 71: Detail from the cover of a three-colored box (Wirgin 1960, 25-46, fig.8:g)	941
Fig. 72: Lotus rosette on ring-foot dish (detail from Cat. 1053)	941
Fig. 73: Lotus rosette detail from a square dish mold discovered in LQW kiln site (Beijingshi wenwu yanjiusuo 2002.).....	941
Fig. 74: Lotus rosette detail from a square dish mold discovered in LQW kiln site (Beijingshi wenwu yanjiusuo 2002.).....	941
Fig. 75: S-curved petals on the jar and cover (detail from Cat. 655).....	942
Fig. 76: S-curved petals on cover from LQW kiln site (Beijingshi wenwu yanjiusuo 2002)	942
Fig. 77: Scrolling vines on bag-shaped pilgrim flask (detail from Cat. 82).....	942
Fig. 78: Scrolling vines on bag-shaped pilgrim flask (detail from Cat. 89).....	942
Fig. 79: Scrolling vines on bag-shaped pilgrim flask (detail from Cat. 90).....	943
Fig. 80: Scrolling vines on bag-shaped pilgrim flask (detail from Cat. 92).....	943
Fig. 81: Scrolling vines on bag-shaped pilgrim flask (detail from Cat. 62).....	943
Fig. 82: Scrolling vines on bag-shaped pilgrim flask (detail from Cat. 70).....	943
Fig. 83 : Leaf scroll on the mouth rim of oblong lobed dish (detail from Cat. 1177)	944
Fig. 84 : Leaf scroll on the mouth rim of oblong lobed dish (detail from Cat. 1181)	944
Fig. 85 : Leaf scroll on the mouth rim of oblong lobed dish (detail from Cat. 1185)	944
Fig. 86 : Leaf scroll on the mouth rim of oblong lobed dish (detail from Cat. 1198)	944
Fig. 87 : Leaf scroll on the mouth rim of oblong lobed dish (detail from Cat. 1186)	944
Fig. 88 : Leaf scroll on square dish (detail from Cat. 1146).....	944
Fig. 89 :Leaf scroll on the mouth rim of square dish mold from LQW kiln site(Beijingshi wenwu yanjiusuo 2002).....	945
Fig. 90 : Leaf scroll on the mouth rim of square dish mold from LQW kiln site (detail from Cat. 1143).....	945
Fig. 91 : Leaf scroll on cover from LQW kiln site(Beijingshi wenwu yanjiusuo 2002)	945
Fig. 92: Scroll cloud on inkstone (detail from Cat. 1206).....	945

Fig. 93: Leaf scroll on shoulder of ewer (detail from Cat. 422)	945
Fig. 94: Scroll cloud-detail from a stone stele of a tomb at xigushan, Jinxi, Liaoning. (Yan Wanzhang 1957, 69-82, fig.1).....	946
Fig. 95: Plantain leaves on ewer and bowl (detail from cat. 960, Cat. 418)	946
Fig. 96: Plantain leaves on ewer and bowl (detail from Cat. 416).....	946
Fig. 97: Plantain leaves on ewer (detail from Cat. 419).....	946
Fig. 98: Plantain leaves on jar (detail from Cat. 663).....	946
Fig. 99: Plantain leaves on jar (detail from Cat. 662).....	946
Fig. 100: Plantain leaves on ewer (detail from Cat. 422).....	946
Fig. 101: Plantain leaves on ewer	946
Fig. 102: Plantain leaves on ewer (detail from Cat. 492).....	947
Fig. 103: Plantain leaves on bowl (detail from Cat. 921).....	947
Fig. 104: Stippling plum blossom on bag-shaped pilgrim flask (detail from Cat. 220)	947
Fig. 105: Stippling plum blossom on ewer (detail from Cat. 472).....	947
Fig. 106: Butterfly on triangular dish, Five Dynasties. (detail from Cat. 1158).....	947
Fig. 107: Butterfly on square dish (detail from Cat. 1134).....	948
Fig. 108: Butterfly on square dish (detail from Cat. 1135).....	948
Fig. 109: Butterfly on Liao amber box (detail from Cat. 1161).....	948
Fig. 110: Detail from a Yue ware dish (Feng Xianming, 1973, 20-29, fig.2)	948
Fig. 111: Detail from a Ding ware dish (Feng Xianming, 1973, 20-29, fig.1)	948
Fig. 112: Butterfly (or bee) on a bowl shard from GWYC kiln site (Lu Jing 2003, 323, pl. 4-370)	948
Fig. 113: Butterfly (or bee) on a bowl shard from GWYC kiln site (Lu Jing 2003, 323, pl. 4-369)	948
Fig. 114: Butterfly (or bee) on oblong lobed dish (detail from Cat. 1181)	949
Fig. 115: Butterfly (or bee) on oblong lobed dish (detail from Cat. 1182)	949
Fig. 116: Butterfly (or bee) on oblong lobed dish (detail from Cat. 1177)	949

Fig. 117: Butterflies on ocarina (detail from Cat. 1225).....	950
Fig. 118: Fish on oblong lobed dish (description see Cat. 1184, Cat. 1185).....	950
Fig. 119: Fish on basin (description see Cat. 731)	950
Fig. 120: Fish on the handle of ewer (description see Cat. 489)	951
Fig. 121: Dragon-fish (makara) on stone carving at Amaravati, India. Circa 200-205 B.C. (after Cen Rui 1983, 78-80, fig.2).....	951
Fig. 122: Dragon-fish (makara) on coffin of the tomb of Li He at Shangshengcun, Sanyuanxian, Shaanxi, Sui Dynasty. (after Cen Rui 1983, 78-80, 85 fig.1: left).....	951
Fig. 123: Dragon-fish (makara) on coffin of the tomb of Li He at Shangshengcun, Sanyuanxian, Shaanxi, Sui Dynasty. (after Zeng Yu 1984, 33-36, fig.2).....	951
Fig. 124: Detail from a silver plate unearthed at Dingmaoqiao, Dantu, Jiangsu. Tang dynasty. (Zeng Yu 1984, 33-36, fig. 6:A).....	951
Fig. 125: Detail from a gold cup unearthed at Xian, Shaanxi. Tang dynasty. (He Lin et al. 1983, p.14).....	951
Fig. 126: Detail from a silver plate unearthed at Kalaqin Banner, Inner Mongolia. Tang dynasty. (Cen Rui 1983, 78-80, fig.5).....	952
Fig. 127: Gilt silver plaque decorated with two dragon-fish chasing pearls. Unearthed from SQ1 tomb, Beipiao, Liaoning. Liao product. 10th century. L: 18cm, W: 10.5cm. (Xu Yulin 1971, 44-51, fig.5)	952
Fig. 128: : Dragon-fish formed ewer (description see Cat. 508)	952
Fig. 129: Dragon-fish formed ewer (description see Cat. 506)	953
Fig. 130: Phoenix on a shard from GWYC kiln. (Zhou Jie 1973, 241-243, fig:2).....	953
Fig. 131: Phoenix incised on a white glazed bowl unearthed from GYY tomb, dated to 1026. D: 21cm. (Zhu Zifang & Xu Ji 168-195, fig. 4:9).....	953
Fig. 132: Phoenix incised on a guan marked white glazed dish unearthed from YMT7. Probably Ding ware. 10th century. D: 15.6 cm. (Feng Yongqian 1975, 40-48, fig. 1:1).....	954
Fig. 133: Dragon on bag-shaped pilgrim flask (detail from Cat. 66)	954
Fig. 134: Monkey on bag-shaped pilgrim flask (detail from Cat. 56).....	955
Fig. 135: Monkey sculpture (detail from Cat. 1296).....	955
Fig. 136: : Monkey sculptures unearthed from LQW kiln (Beijingshi wenwu yanjiusuo 2002)	955

Fig. 137: Human motif on bag-shaped pilgrim flask (detail from Cat. 70)	956
Fig. 138: Firing-ball motif on bag-shaped pilgrim flask (detail from Cat. 57).....	958
Fig. 139: Firing-ball motif on bag-shaped pilgrim flask (detail from Cat. 60).....	958
Fig. 140: Whirling floral design on basin (description see Cat. 748)	958
Fig. 141: Whirling floral design on basin (description see Cat. 749)	959
Fig. 142: Sun floral design on basin (description see Cat. 727)	959
Fig. 143: Whirling floral design on basin (description see Cat. 729)	959
Fig. 144: Net floral design on basin (description see Cat. 714)	959
Fig. 145: Layout of the designs on three-colored oblong lobed dish-Type A (detail from Cat. 1185).....	959
Fig. 146: Layout of the designs on three-colored oblong lobed dish-Type B (detail from Cat. 1181).....	959
Fig. 147: Layout of the designs on three-colored oblong lobed dish-Type C (detail from Cat. 1201).....	960
Fig. 148: Layout of the designs on three-colored oblong lobed dish-Type D (detail from Cat. 1186).....	960
Fig. 149: Layout of the designs on three-colored eight lobed dish-Type A (detail from Cat. 1111)	960
Fig. 150: Layout of the designs on three-colored eight lobed dish-Type B (detail from Cat. 1110)	960
Fig. 151: Layout of the designs on three-colored eight lobed dish-Type C (detail from Cat. 1114)	960
Fig. 152: Layout of the designs on three-colored eight lobed dish-Type D (detail from Cat. 1112)	960
Fig. 153: Layout of the designs on three-colored square dish (detail from Cat. 1148)	961
Fig. 154: Layout of the designs on three-colored square dish (detail from Cat. 1144)	961
Fig. 155: Layout of the designs on three-colored round dish- Type A (detail from Cat. 1037).....	961
Fig. 156: Layout of the designs on three-colored round dish- Type B (Lu Jing 2003, 331, pl. 4-422)	961
Fig. 157: Layout of the designs on three-colored round dish- Type C (Lu Jing 2003, 332, pl. 4-424)	961

Fig. 158: Layout of the designs on three-colored round dish- Type D (detail from Cat. 1050)	961
Fig. 159: Layout of the designs on outer wall of three-colored inkstone (description see Cat. 1206)	962
Fig. 160: Layout of the designs on outer wall of three-colored inkstone (description see Cat. 1213)	962
Fig. 161: Layout of the designs on over surface of three-colored inkstone (description see Cat. 1206)	962
Fig. 162: Layout of the designs on outer wall of three-colored box (description see Cat. 1276)	963
Fig. 163: Inscription incised on shoulder of vase (Lu Jing 2003, 335, pl. 4-443)	965
Fig. 164: Guan mark on bottle (detail from Cat. 286)	966
Fig. 165: Guan mark on ewer (detail from Cat. 452)	966
Fig. 166: Guan mark on ewer (detail from Cat. 433)	966
Fig. 167: Guan mark on jar (detail from Cat. 657)	966
Fig. 168: Mural painting of GYY tomb at Guyingzi, Chaoyang, Liaoning Province, dated to 1026. (after Zhu Zifang & Xu Ji 1983, 168-95, fig.13)	968
Fig. 169: : Mural painting of EBD tomb at Keshiketeng Banner, Inner Mongolia. (after Xiang Chunsong 1984, 89-90)	968
Fig. 170: Mural painting of a Liao tomb at Kangyingzi, Aohan Banner, Inner Mongolia. (after Xiang Chunsong 1979, 22-32, fig. 11:5)	968
Fig. 171: : Mural painting of a Liao tomb at Kangyingzi, Aohan Banner, Inner Mongolia. (after Xiang Chunsong 1979, 22-32, fig. 11:2)	968
Fig. 172: : Mural painting of Southeast wall of ZGY tomb, Xuanhua, Hebei Province. (after Hebeisheng wenwu yanjiusuo 2001)	969
Fig. 173: : Mural painting of GYY tomb at Guyingzi, Chaoyang, Liaoning Province, dated to 1026. (after Zhu Zifang & Xu Ji 1983, 168-95, fig.13)	969

CHAPTER 1 INTRODUCTION

1.1 INTRODUCTION

This introductory section will provide an outline of both the scope of this dissertation and the methods applied, as well as a list of the sources of my study materials. Moreover, it will identify my research objectives and refer to difficulties encountered during my analytical work.

1.1.1 The Scope of This Study

The term “Liao ceramics” normally falls into a narrow definition on the one hand and a generalized definition on the other hand.

The narrow definition designates ceramics made in Liao territory and used by the residents of the Liao Empire. Among these are, firstly, the most characteristic ceramics utilized by nomadic Khitan people – i.e. the bag-shaped pilgrim flask, the long-neck vase, the chicken-leg vase, the phoenix-head vase, and the oblong lobed dish - and secondly, the Han-style ceramics manufactured and handled by the Han people.

The generalized definition of Liao ceramics is an extension of the narrow definition, additionally including related ceramics which were used but not fabricated by the residents of the Liao Empire, e.g. several Ding and Cizhou wares from Hebei, Central China, and Qingbai wares from Jiangxi province, South China. Accordingly, the generalized definition remains slightly imprecise, and it is important to recall that only those ceramics produced by the Liao qualify as truly authentic wares, whereas the related ceramics, fabricated in other areas of China and used by the Liao, cannot unrestrictedly function as representatives of Liao culture and technology.

Hence, for the purpose of this study, I will apply the narrow definition of Liao ceramics as specified above, which comprises the glazed ceramics produced within the territory of the Liao Empire. Temporally, the focus of my dissertation will be on the period from the establishment of the Liao Empire in 907 AD¹ to its replacement by the Jin dynasty in 1125 AD. In terms of geography, the narrow definition refers to the large territory of the Liao Empire, including today’s northeastern Inner Mongolia, Liaoning province, the northern Hebei province, Beijing, Tianjin, Jilin, and part of Heilongjiang province. In the context of ceramics, it comprises glazed, low-fired earthenwares, glazed, high-fired stonewares, and porcelains; unglazed wares, however, are only rarely included. Further to be noted is that

¹ The Liao dynasty was established in 907 by Yelü Abaoji who, thenceforward, named himself the Great Han (Khan) of the Khitan. In 916, Abaoji appointed himself emperor of the state he had named “Kithan”; his successor, Emperor Taizong, altered the state name from “Khitan” to “Great Liao” in the year 938; Emperor Shengzong renamed it yet again to “Great Khitan” before, in 1066, it was changed back to “Great Liao”, the designation which was to remain valid until the fall of the dynasty. While the majority of Chinese historians have considered 916 AD to mark the beginning of the Liao dynasty, most Western historians predate it to 907 AD; the latter dating also forms the basis of this study. Henceforth, I will omit the specification “AD” when referring to ancient Chinese periods.

glazed Liao ceramics account for the majority, i.e. approximately 80%, of unearthed Liao funeral objects (Chart 10). Pieces of unglazed pottery conventionally put to use as funeral objects, mainly occur in tombs of the Han people of the Liao dynasty (Chart 14) and in a number of lower class Khitan tombs (Chart 13).

In this study, the identification of ceramics from Liao tombs will be based on excavation reports, expert studies, and on my personal experience acquired during numerous investigations of Liao kiln sites. The observations which I could draw from the large quantities of unearthed Liao ceramics on location constitute an important element of my discussion.

1.1.2 Methods

Fundamentally, my study is based on Liao ceramics which have been unearthed from dated Liao tombs. Only by comparing pieces from this group of ceramics with other unearthed objects, and by referring to similarities between forms of burial chambers, will it be possible to roughly determine the age of otherwise undated tombs. Therefore, in a first step, I will provide an outline of all relevant dated Liao kiln sites, summarizing their geographical, temporal, and technical details.

Subsequently, the study results acquired on the basis of these premises will be employed to create a typological summary of the unearthed ceramic materials.

In the following, this typological analysis will be used to classify Liao ceramics by stages, and furthermore, to summarize the evolution of Liao ceramics at different phases. Additionally, several timeline tables of diverse shapes of Liao ceramics will be drawn up.

Furthermore, according to these timeline tables of unearthed ceramics, several Liao ceramic collections from museums and private sources will be approximately identified and dated. Ideally, it would be possible to employ scientifically sound methods to identify Liao ceramic collections; yet, in the present study environment, facing the continuous lack of a comprehensive scientific database as well as dealing with the damage done to some collections, the methods I have chosen to conduct this study are as valid as they can possibly be.

Finally, I will use the results drawn from the first four steps of my analysis to construct a chronological framework of Liao ceramics and thus create a relatively reliable foundation for future analyses in this field of study.

Where it was not possible for me to obtain and analyze samples myself, I have reviewed results from former scientific studies. Fortunately, the multitude and high quality of these analyses grant a valid basis for the study of Liao ceramics.

From several wall paintings of Liao tombs it is possible to obtain clues as to the usage of Liao ceramics. This aspect will also be considered in my study.

1.1.3 Sources of Study Materials

The ceramic materials I have examined for this study include all published Liao ceramics unearthed from Liao tombs, kiln sites, and other sites before 2006. Further included are Liao ceramic collections from museums worldwide, as well as several pieces of Liao ceramics in private hands.

The text material quoted in this dissertation comprises international reports on said collections, published before 2006.

1.1.4 Problems and Objectives

Despite the fact that more than seventy years have passed since Liao ceramics became a scientific field of study in the 1930s, fundamental deficiencies remain:

1. The quantity of recovered material from Liao kiln sites remains small, and articles have only been published on a minority of these finds. As a matter of fact, merely two Liao kiln sites, the LQW and GWYC kilns, have ever been scientifically excavated, and to this day, only the excavation report of the LQW kiln site in Beijing has been published². Consequently, the present stage of Liao ceramic studies lacks scientifically unearthed materials from Liao kiln sites. In order to amend this insufficiency, I have personally investigated a majority of the important Liao kiln sites in Inner Mongolia, Liaoning, Shanxi province, and Beijing over a period of several years, collecting hundreds of shards of Liao ceramics and firing instruments from the grounds. Moreover, I have examined numerous exposed profiles. My findings on these shards will form an important supplement to this study.
2. Due to historical and political reasons, large numbers of exquisite Liao ceramics were scattered to Japan and other western countries before World War II. Recalling previous publications from all around the world, it transpires that the works of foreign scholars of Liao ceramic studies mainly concentrate on collections made available to them by their local museums, whereas the studies of Chinese scholars primarily focus on Liao ceramic collections in China. While the term of Liao ceramics is an integral concept, regardless of whether findings were made in or outside of China, no one book has ever successfully combined both strands of Liao ceramic studies to this day. Thus, it is essential and feasible to create a comprehensive study at the present stage of research.
3. On Account of the language barrier, newly excavated Chinese Liao ceramics from Liao tombs or kiln sites are relatively difficult for western scholars to obtain and utilize for their studies. Due to this circumstance, very few articles and books on the study of Liao ceramics have been published in English over the last twenty years, and the cognitive degree of respective studies has not been advanced since. Yet, with ever more discoveries of Liao ceramics coming to light, the field's research database deserves to be updated and expanded by the newly available information. Moreover, a comprehensive study in English is urgently awaited by archeologists around the world, and I hope to supply this need by way of this dissertation.

2 Beijingshi wenwu yanjiusuo 2002.

4. After the Liao dynasty was conquered by the Jin dynasty in 1115, a number of Liao's noble citizens escaped westward to the area of Turkestan where, in 1131, they established a new empire in Central Asia, known to Muslims as the Qara Khitai (the Black Khitans), and as Western Liao to the Chinese. The empire existed for nearly ninety years, until it was vanquished by the Mongols in 1218. A branch of the Khitan people escaped to the north of today's Iran, where they were eventually assimilated into the local community. Due to this historical circumstance, it appears that the resulting particular relationship between Liao, Central Asia, and Iran should be traceable on contemporary ceramics from these regions; however, no studies have been published up-to-date, concerning questions such as: Is there evidence of a connection between Liao and Islam ceramics? And, if yes, what exact appearance does it take? Unfortunately, I cannot further pursue this aspect, as an excursion into Islamic ceramics would go beyond the scope of my study.
5. Previous investigation reports on Liao kiln sites have been rather sketchy and contained very few illustrations, making it difficult to draw a substantial understanding from them. Therefore, I will include in numerous photos of Liao ceramics' shards and kiln sites which were taken during my field work in this study. The majority of these first-hand materials will be entirely novel to the public, and will hopefully inspire future analyses.
6. How can Liao white wares be distinguished from Ding wares, Xing wares, and Cizhou wares? How to discern Liao three-color-glazed ceramics from Tang three-color-glazed ceramics? Such questions of definition are another central concern of this thesis. As they have frequently been addressed in former studies by the aid of scientific analyses and databases, and as I am unable to conduct an analysis of such extend with the means available to me, I instead take this opportunity to compose a comprehensive summary of previously published results on the topic. –

1.2 GEOGRAPHICAL FRAMEWORK

1.2.1 Geographical Borders

The Liao Empire was established on the Manchurian Plain from where it expanded to the east and the southwest, in the course absorbing the realms of the Xi 奚 and Bohai 渤海, and occupying sixteen prefectures (zhou 州) of the later Jin dynasty (Houjin 后晋) in 937. Over the following decades, Liao troops repeatedly invaded Song China (a conflict only transiently resolved by the 1004 peace treaty of Chanyuan 澶渊) and attacked the Korean empire of Goryeo 高丽.

The territory of the Liao Empire was bordered in the south by the line of the Great Wall and northern Shanxi. It continued due east across the area of what is today the northern part of Hebei province, including the region which has become the site of the capital city Beijing. The province of Liaoning, covering almost the whole of Inner Mongolia, was also under Liao control. For some time, the allegiance of the Khitan with certain governors of eastern China seemed to promise the fulfillment of the Khitan ruler's ambition to be seen

as the emperor of the whole of China; yet, in spite of such intermittent alliances, the frontier described above was reaffirmed by both sides during the brief reigns of the late Jin and the late Zhou dynasties in northeastern China. The emperors of the northern Song dynasty (960-1127) made no effort to destroy Khitan power, but instead suffered occasional raids by the northerners, even paying them a handsome annual tribute so they would refrain from further attacks. In 1114, Khitan forces were finally defeated and dispersed by their nomad adversaries.

At the beginning of the 12th century, the territory of the Liao dynasty reached its largest extent. In the east, it stretched to the coast of the Northern Sea, the Eastern Sea, the Yellow Sea, and the Bohai Sea; in the west, it ranged to the Altai Mountain and the Bailongdui Desert in Xinjiang; in the north to the Kelulun, the E'erkun, and the Selun'ge Rivers; in the northeast to the southern ridge of the Outer Xing'an Mountains; in the south to the northern part of the Shanxi, Hebei, and Gansu provinces.

1.2.2 Administrative Division (Main Residents)

Imitating the administrative pattern of the Song, the Khitan ran five capitals, around the circuits of which the majority of the population resided. Each of these capitals was the seat of an administration (dao 道)(see Table 1).

Table 1 The Five Capitals of the Liao Dynasty

Capital	Prefecture	Present-Day Place
Supreme Capital (Shangjing 上京)	Linhuang 临潢	Balin Left Banner, Inner Mongolia
Central Capital (Zhongjing 中京)	Dading 大定	Ningcheng, Liaoning
Eastern Capital (Dongjing 东京)	Liaoyang 辽阳	Liaoyang, Liaoning
Western Capital (Xijing 西京)	Datong 大同	Datong, Shanxi
Southern Capital (Nanjing 南京)	Xijin 析津	Beijing

The Supreme Capital (Shangjing) was established within the old Khitan grazing grounds of northwestern Inner Mongolia in 918, between the upper course of the Huang River (today's Shira Muren) and the Xing'an Mountains. The ruins found at the site of the Mongol city of Bore Khoton correspond closely to the historical record, both in their

general arrangement and in more conspicuous details depicting: two "cities" with walls of different heights, the same number of gates similarly located, etc.³ Therefore, it is arguably more reasonable to consider Bore Khoton the original site of the Supreme Capital than to follow earlier identifications which locate the city farther to the northwest.

The Eastern Capital (Dongjing), situated in the southern part of the Manchurian Plain in 928, is now the site of Liaoyang, Liaoning province.

The Southern Capital (Nanjing) was practically identical with the present-day capital of China, Beijing, which was established in 938.

The Central Capital (Zhongjing) was established at a relatively late date in 1007.⁴ It was located in the mountainous regions of southern Inner Mongolia, near the Shira Muren's southern tributary, then called the Tu River and known today as the Laoha River.⁵

The Western Capital (Xijing) was the latest capital which was established in Liao dynasty, the established date is in 1044. It is situated in the northern part of the present-day Shanxi province, in the region of Datong, which was known by that name even at the time of the Liao Empire.

Each of the five capitals controlled a territory or circuit (dao) registered in the name of its principal city. In order to distinguish the capital cities from their circuits, which the Chinese text often fails to do, the English equivalent will subsequently be given to refer to the capital, while the Romanized Chinese form will be retained for its respective circuit. Thus, Shangjing 上京 will be rendered, according to the context, as either Supreme Capital (meaning the city itself), or as Shangjing (meaning its circuit).

1.3 HISTORICAL FRAMEWORK

1.3.1 History and Society

1.3.1.1 Historical Background

The Liao dynasty was a regime established by the Khitan (Qidan 契丹) tribe. It was on the northeastern steppe of today's Mongolia and Manchuria, where part of the so-called Eastern Hu (Donghu) people, for instance the Khitan and the Xi, roamed. The name Khitan first appears in Northern Wei (Beiwei) sources, but scarcely any detailed information exists on the early period of the Khitan people.

Evidently, they divided into eight tribes and settled in the area between the Huang River (the present Shira Muren in Inner Mongolia) and Huanglong (contemporary Chaoyang in Liaoning). Commercial relationships with the northern Wei court were entertained, and horses and skins were "exported". During the Tang dynasty, the Kithan fought against the Turks (Chinese: Tujue); subsequently, the Kithan ruler, Kuge of the Dahe clan, who had

3 Wittfogel, Karl August, and Chia-shêng Fêng 1949, 44-45.

4 Wittfogel, Karl August, and Chia-shêng Fêng 1949, 44-45.

5 Wittfogel, Karl August, and Chia-shêng Fêng 1949, 44-45.

united the tribes in a federation, was installed as governor (dudu) of the Songmo region and given the imperial family name Li. His descendants acted as local governors for several decades before Li Jinzhong rebelled against empress Wu Zetian. Later on, Li Shihuo was presented with a Chinese princess named Yongle.

Shortly before the An Lushan rebellion, the Khitan opposed the Tang dynasty one last time; for the remainder of the Tang period, good relations were retained. In 730, the Yaonian clan was in control and produced a number of khans (Chinese: kehan); however, the Yelü clan dominated over the Khitan federation from 907 onwards. Yelü Abaoji, the chief of the Khitan tribe, established the Khitan Kingdom in 916 and proclaimed himself its emperor. Historically, Yelü Abaoji is referred to as Emperor Taizu. Two years later, he erected his capital north of the Shira Moren River and named it Huangdu (Imperial Capital). In 947, Emperor Taizong renamed his dynasty "Great Liao"; yet Emperor Shengzong revived the name Khitan in the year 983, and in 1066, Emperor Daozong restored the name "Great Liao". As per Western merchants' acceptance, the name of China proper was changed into Khitan.

In the wake of the foundation of the kingdom in 907, Abaoji gradually conquered its weak neighboring tribes. In 926, he vanquished the Uigurs in Ganzhou and captured Bohai State.

Emperor Taizong (Yelü Deguang) reigned from 926 to 947, a period during which the Liao dynasty expanded into territory which reached from the Mongolian border into Manchuria, and comprised the sixteen prefectures south of the Great Wall. The latter area was to remain outside of Chinese control for over 400 years, a circumstance which posed a serious threat to the Northern Song (960-1127). However, the region simultaneously functioned as a center for the mutual cultural exchange between the Chinese and the northern people.

After obtaining the sixteen prefectures, Liao founded an additional capital in Yanjing, on the site of contemporary Beijing. From this base, they began their expansion into the Central Plains where, in 946, they took Kaifeng, the capital of the Song dynasty, and proceeded to attack the weak troops of the civil-oriented Song government. Yet, due to tenacious resistance in the Central Plains, the latter attempt eventually had to be abandoned.

Between the reigns of the emperors Taizong and Jinzong, political disputes troubled the Liao court.

Upon the death of Jinzong, his 12-year-old son Yelü Longxu, historically known as Emperor Shengzong, succeeded him to the throne. As the new emperor was too young to conduct state affairs, the court was in fact controlled by his mother, Empress Xiao. She appointed Yelü Xiuge to be her senior general, and in 987 waged a war against and defeated the Song army. Thenceforward, warfare between the two countries never stopped until the end of the Liao Empire.

Weary of the ceaseless skirmishes with the nomad people – Liao had launched another war in 1004 - the Song proposed them with the Chanyuan Treaty in 1005. It required the Liao to ensure quiet frontiers in exchange for the payment of an annual tribute by the Song.

After the treaty was signed, the nature of the relationship between these two states changed from one of purely political rivalry to a supposedly fraternal one. For the first time in Chinese history there were two Sons of Heaven, each recognizing the other.

By aid of the tribute paid by the Song, the Liao dynasty rapidly progressed and reached its peak, both economically and politically.

The conclusion of the Chanyuan Treaty marked a turning point in the relations between the Song and the Liao; with their signature the Song, who considered themselves the natural heirs to political dominance and their state to be the Central Kingdom, recognized Liao legitimacy for the first time in history. The peaceful relationship lasted until 1125, when the Song broke the truce by inviting the Jin to attack the Liao.

After the prosperity enjoyed during the reigns of the emperors Shengzong and Xingzong, the Liao dynasty fell into decline. In the early years of the 12th century, the Jurchen tribe gradually grew in strength and became a great threat to the Liao. By 1115, the Jurchen had established their own dynasty, Jin dynasty (1115 - 1234), with Aguda as their emperor. In the same year, the Jin army captured Huanglong, a strategically important town of the Liao. Subsequently, the Jurchen established an alliance with the Song so as to attack the Liao; yet, the Song would come to regret this coalition when they were defeated by the Jurchen, and witnessed them establish themselves as the Jin dynasty in 1115.

As a consequence of economical disasters and internal quarrels, the Liao government became brittle, and soon the Jin army occupied most of Liao's territory. In 1125, Emperor Tianzuo was captured by the Jin army, an act effectively ending the Liao dynasty.

In 1131, Yuelü Dashi, a minister of former Liao, reestablished the Liao in the Chuhe valley by assembling those troops and tribes which had survived the Jin armies and had moved it to Zhenzhou. The Chuhe Valley subsequently became known as Western Liao.

Yuelü Dashi subdued Uyghur and Turkish tribes, and moved his capital to Balashagun (situated in today's Kirgizstan, also known as Husi Woluduo, Kuc-Ordo, or Kus-Ordo). His empire, which he expanded further to the west and into the city states of the Tarim Basin, was also known by its Turkish name Qara-Khitai (Chinese: Halaqidan) or Black Khitan. **(Map 4)** Women of the imperial clan, like Empress Chengtian, influenced the empire after the death of Yelü Dashi (posthumous title Xiliao Dezong). In 1211, Naiman, chieftain Kücülüg (Chinese: Quchulü), required shelter in the Western Liao court and consequently forced Yelü Zhilugu to cede. The Western Liao Empire was conquered by the Mongols in 1218.

1.3.1.2 Political System

The Liao dynasty claimed to be the legitimate successor to the Tang. They incorporated their own tribes under respective chieftains and formed a confederation with other

subdued tribes in the region - a constellation which was eventually transformed into a hereditary monarchy.

The Liao employed a differential rule, i.e. different political systems were applied to people from different cultures and economies in different areas. The kinds of administrative orders most often applied were the tribal system, the slavery system, the Bohai system, and for the Han people, the feudal system.

For the Khitan people, a tribal system was adapted, in which they maintained their traditional rites, and to a great extent, retained their own style of cuisine and clothing. Accordingly, for the Han people, particularly in the farming region, the political system established under the Tang was reserved, including the use of Tang official titles, an examination procedure for the appointment of the civil service, and a Chinese-style tax regime. Moreover, the Chinese language continued to be used and the customs of the Han were kept.

At the time, officials were divided into two groups, according to whether they came from the north or the south; corresponding systems of administration were set up for each area. On the one hand, the Khitan administrative system, known as the orthodox system, was applied to Khitan officials, i.e. northern officials. On the other hand, the Han administrative system was applied to the Han officials, i.e. southern officials. On account of disparate customs and levels of economic development, the northern officials mainly governed the Khitan Tartars and other nomadic peoples, while the southern officials took charge of agricultural areas mainly populated by the Han people. As the Liao dynasty had been founded by the Khitan, northern officials were superior in status to their southern counterparts, regardless of the fact that the southern administrative system was actually that feudal order which had been practiced in the Central Plain states. After the Liao conquered the sixteen prefectures in the Yanyun area, this system was further improved.

1.3.1.3 Social Economy

Liao went through different stages of economic development. In its early years, while mainly dependent on expansion, slavery, and thievery, its economic growth was slow and disrupted. It was not until the reign of Emperor Shengzong, that Liao rulers managed to institute a feudal reform coupled with the adoption of a differential economic management system, which effected a distinct economic progress throughout the north.

The economy of Liao was based on horse and sheep breeding, as well as on agriculture; fishing played an important complementary role. Those engaged in agriculture were predominantly Han people in the south and Bohai people in the east - was populated by various northern grassland; the fishing-hunting zone covered the Khitan area between the rivers Shira Muren and Tuhe, and the territory of the Jurchen people in the northeast. The integration of the three economic zones into a political system advanced communication between different nationalities and promoted their economies to a higher level. The oldest feudal economy of the three zones in the south dominated this commercial coalition. Importantly, the supply of salt was controlled by government

monopoly, providing an important source of revenue. Iron smelting was also an important industrial contribution to the wealth of the dynasty.

1.3.2 A Chronology of Liao Emperors

Table 2 Chronology of the Liao Dynasty (907-1125 AD) ⁶

Temple Names	Birth Names	Periods of Reigns	Eras
Taizu (太祖)	Yelü Abaoji (耶律阿保机)	907-926	Shence (神册) 916-922 Tianzan (天赞) 922-926 Tianxian (天显) 926
Taizong (太宗)	Yelü Deguang (耶律德光)	926-947	Tianxian (天显) 927-938 Huitong (会同) 938-947 Datong (大同) 947
Shizong (世宗)	Yelü Ruan (耶律阮)	947-951	Tianlu (天禄) 947-951
Muzong (穆宗)	Yelü Jing (耶律璟)	951-969	Yingli (应历) 951-969
Jingzong (景宗)	Yelü Xian (耶律贤)	969-982	Baoning (保宁) 969-979 Qianheng (乾亨) 979-982
Shengzong (圣宗)	Yelü Longxu (耶律隆绪)	982-1031	Qianheng (乾亨) 982 Tonghe (统和) 983-1012 Kaitai (开泰) 1012-1021 Taiping (太平) 1021-1031
Xingzong (兴宗)	Yelü Zongzhen (耶律宗真)	1031-1055	Jingfu (景福) 1031-1032 Chongxi (重熙) 1032-1055
Daozong (道宗)	Yelü Hongji (耶律洪基)	1055-1101	Qingning (清宁) 1055-1064

⁶ This table is based on http://en.wikipedia.org/wiki/Liao_Dynasty#Liao_Dynasty_907-1125.

			Xianyong (咸雍) 1065-1074 Taikang (太康) or Dakang (大康) 1075-1084 Da'an (大安) 1085-1094 Shouchang (寿昌) or Shoulong (寿隆) 1095-1101
Tianzuo(天祚帝)	Yelü Yanxi (耶律延禧)	1101-1125	Qiantong (乾统) 1101-1110 Tianqing (天庆) 1111-1120 Baoda (保大) 1121-1125

1.4 PREVIOUS STUDIES

1.4.1 1920s-1940s

1.4.1.1 An Initial Definition of Liao Ceramics

It was not until the early 20th century that Liao ceramics were noticed by archeologists, following an area excavation of the northeastern region of China performed by the Japanese during a period of occupation.

The resurrection of the Liao Yongqing mausoleum⁷ in particular, made a name for Liao ceramics. In 1930 and 1931, Japanese scholars Torri Ryuzo and Namio Egami, respectively conducted an investigation thereof, subsequently venturing an initial tentative definition of Liao ceramics.⁸

By 1935, a large collection of Liao ceramics had been accumulated in the Mukden (today's Shenyang) Museum,⁹ the late mansion of Tang Yulin 汤玉麟, governor of the former Rehe province¹⁰. In order to increase the number of treasures in his father's newly built residence, his son had ordered a large quantity of relics. These were to be obtained by resurrecting the Liao tombs in Chifeng, Inner Mongolia, which contained numerous pieces of Liao ceramics. Following the establishment of the Japanese puppet-state Manchukuo,

7 It was the tomb of the empire of Shengzong (983-1031), located in Suoborigasumu, Balin Left Banner, Inner Mongolia.

8 Kuroda Genji & Sugimura Yuzo, 1958.

9 The proto-museum of the Liaoning Museum, located in Shenyang City, Liaoning Province.

10 Rehe (simplified Chinese: 热河省; traditional Chinese: 熱河省; pinyin: Rèhé shěng; literally "Hot River"), also known as Jehol, is a defunct Chinese province that used to consist of part of today's Hebei province, Liaoning province and Inner Mongolia in north-eastern China.

the mansion was turned into the Mukden Museum by the new government; its collections were enhanced by the Liao relics which the Japanese unearthed, and put up for public exhibition.¹¹

In 1933, Kuroda Genji and Yamashita Taizo, while preparing this exhibition, distinguished Liao ceramics from other potteries, specifically defining the bag-shaped pilgrim flask¹², the chicken-leg vase, and several three-color-glazed ceramics as Liao wares. The bag-shaped pilgrim flask (cock's-comb bottle), was thus noticed by experts for the very first time, marking the starting point of the long-due recognition of the importance of Liao ceramics.

1.4.1.2 Liao Kiln Sites

From the beginning of the 1930s until 1944, several Liao kiln sites were discovered, including the Gangguantun (GGT) kiln site in Liaoyang, the Daguantun (DGT) kiln at Fushun, Liaoning, the Gangwayaocun (GWYC) kiln at Chifeng, as well as the Shangjing (SJY) and Baiyingele (BYGL) kilns at Lingdong, Balin left Banner, Inner Mongolia.

The site of GGT kilns in Liaoyang, Liaoning, was located at the beginning of the 1930s, but unfortunately many pieces were destroyed in the course of the ruthless excavations conducted by the Japanese occupants.¹³

In 1937, Sugimura Yuzo reported the discovery of the Daguantun kiln site in Fushun, Liaoning.¹⁴

Tamura Jitsuzo found the SJY kiln site in Lindong, Balin left Banner, Inner Mongolia, and collected some white-glazed and black-glazed shards from the grounds in 1939.¹⁵ From 1940 to 1944, Koyama Fujio, Kuroda Genji, and Li Wenxin investigated the SJY kiln site, performing a tentative excavation thereof.¹⁶

In 1942, a Japanese Buddhist priest found the GWYC kiln in Chifeng, Inner Mongolia, and collected a number of fragments, thereby attracting the attention of the Japanese. In 1943, Yukibushi Uehara¹⁷ and Takeichi Saito investigated the GWYC kiln, arriving at a preliminary understanding of its range, the varieties of its ceramic products, the firing instruments employed, etc. A 1944 excavation, organized by Koyama Fujio, Kuroda Genji,

11 Koyama Fujio 1962, 69-81.

12 It was also referred to as a cock's-comb bottle.

13 Komura Toshio 1930, 1933; Li Wenxin, 1951.

14 Sugimura Yuzo 1937, 68-69.

15 Tamura Jitsuzo & Kobayashi Yukio 1953a.

16 Tamura Jitsuzo & Kobayashi Yukio 1953a; Li Wenxin 1958a, 10-22.

17 The Curator of the Mukden Museum.

and Yukibushi Uehara, was also performed at the GWYC kiln. The attendant Chinese scholar Tong Zhuchen published a brief report on the project.¹⁸

1.4.1.3 Liao City Sites and Tombs

Other sites of Liao cities and tombs were found during the first period (1920s-1940s), and even though these remained few in quantity, numerous Liao ceramics could still be recovered from them.

In the early 1920s, French missionary Joseph Mullie traveled to eastern Inner Mongolia to investigate the city sites and tombs of the Liao dynasty. Mullie noticed a number of yellow-glazed and blue-glazed tiles scattered on the ground of the settlements of the Zuzhou, Qingzhou, and Boluocheng city sites, etc.¹⁹

During the 1930s and 1940s, more Liao tombs and settlements were located and excavated, bringing to light a considerable number of burial objects, also including several Liao ceramics. The most noteworthy among these tombs are the XDW tomb at Fuxin, Liaoning province (1925)²⁰, the SFC tomb at Balin Left Banner, Inner Mongolia (1939)²¹, a tomb at the old train station of Jianping, Liaoning province (1939)²², the ZKM tomb at Zhangjiayingzi, Jianping, Liaoning province, and the JGFR tomb at Fuxin, Liaoning province (1949)²³, etc. The earliest pieces of Liao ceramics which have been accurately identified according to the site of their excavation were, for one, a bag-shaped pilgrim flask unearthed from a Liao tomb at the old train station of Jianping city, Liaoning province, a site first discovered in 1939 and cleaned by Li Wenxin in 1940. Furthermore, a dark-green-glazed bag-shaped pilgrim flask was detected in this tomb, which occupies an important position in the research of Liao ceramics (**Cat. 10**).

Up to 1951, more than 300 pieces of Liao ceramics were collected by the Northeastern Museum - successor of the Mukden Museum and predecessor of the Liaoning Provincial Museum - which constituted the foundation for studies to come.

1.4.1.4 Publications

In the first half of the 20th century, research materials of Liao ceramics and scientifically excavated Liao tombs were few and far between. The majority of surveys and excavation studies on Liao kiln sites had been conducted by the Japanese. Following Japanese excavations, publications dealing with archaeological works performed in the old Liao domain were published one after another.

18 Tong Zhuchen 1944, 18-20.

19 Min Xuanhua 1956.

20 Li Wenxin 1958a, 10-22.

21 Li Wenxin 1958a, 10-22.

22 Li Wenxin 1958a, 10-22.

23 Li Wenxin 1958a, 10-22.

Of the earliest important works, it were Torii Ryuzo's four volumes *The Culture of the Liao Dynasty from the Viewpoint of Archaeology*, published in 1936²⁴, which offered a detailed explanation of archaeological investigations of several Liao sites. Additionally, a number of Liao wares were reproduced as illustrations therein, including the bag-shaped pilgrim flasks in brown, green, or white glaze, and a chicken-leg vase.

Several articles of equal relevance for the study of Liao ceramics were published by Yamashita Taizo, Mori Osamu, and Tomita Kojiro.²⁵ The bag-shaped pilgrim flask, the most characteristic vessel form among Liao wares, constituted the focal point of all of these articles²⁶. More comprehensive studies on Liao ceramics were still to come.

Another prestigious paper on the bag-shaped pilgrim flask was put forward by Shimada Sadahiko, who distinguished two types of the bag-shaped pilgrim flask; one tab-styled, the other handle-styled, both of them with a bag-shaped body. Furthermore, Sadahiko indicated that both kinds of the bag-shaped pilgrim flask had been manufactured in China, Japan, and Korea even before the 10th century.²⁷

In brief, during the first half of the 20th century the Japanese conducted more research on Liao ceramics than the Chinese, and in these studies the relationship between China, Japan, and Korea was relatively more concerned. Their works, and particularly the survey and excavation reports on Liao kiln sites, were the harbinger of the study of Liao ceramics.

1.4.2 1950s-1980s

1.4.2.1 Liao Kiln Sites

More Liao kiln sites were detected, investigated, and excavated between the 1950s and the 1980s; the GWYC kiln, the SQG kiln, and the NSY kiln in Inner Mongolia, the LQW, XSY, and CJW kilns in Beijing, and the JZY kiln in Shanxi province, etc. All of these discoveries offered themselves as preconditions for the further in-depth study of Liao ceramics.

1.4.2.2 Liao Tombs and Other Sites

After new China was established in 1949, Chinese archaeologists performed numerous scientific excavations of Liao tombs and other Liao sites. The most distinct feature of Liao ceramic studies during this period was its focus on these discoveries.

Diverse Liao tombs and other sites were found and cleaned out in Inner Mongolia, and in the provinces Liaoning, Jilin, Heilongjiang, Hebei, and Shanxi, as well as in Beijing. (Table 24) Meanwhile, large quantities of Liao ceramics came to light.

24 Torri Ryuzo 1936.

25 Yamashita Taizo 1936, 421; Mori Osamu 1937, 184-187; Tomita Kojiro & Kai-ming Chiu 1948, 122-124.

26 Koyama Fujio 1946; Saito Kikutaro 1942; Shimada Sadahiko 1937.

27 Shimada Sadahiko, 1940.

1.4.2.3 Publications

1.4.2.3.1 Chinese Publications

In China, Li Wenxin was the earliest scholar to attempt a systematic study of Liao ceramics. Based on the archaeological materials available to him, and viewed from aesthetic and technically sound perspective he created the comprehensive research style of Liao ceramics.

Li Wenxin's 1958 "*Summary of Liao Ceramics*"²⁸ represents the first systematic study of Liao ceramics, wherein excavated materials are enumerated, and the features of Liao ceramics' forms and decorations are illustrated in detail. Besides, Li Wenxin was the first to define five varieties of the bag-shaped pilgrim flask. Chronologically, they are shaped in a flattened body with a single tab, a flattened body with double tabs, a flattened body with a looped handle, a long round body with a looped handle, and a short round body with a looped handle. The publication also presents a hitherto unprecedented division of Liao ceramics into two styles, namely the Khitan-style and the Han-style. Comprising these pioneering cognitions, the study constitutes a milestone achievement on the road to subsequent comprehensive analyses.

In a 1961 catalog book of Liao ceramics, edited by the Liaoning Provincial Museum, Li Wenxin contributed the postscript.²⁹ Based on the changes visible in the bag-shaped pilgrim flask and other ceramics unearthed from Liao tombs, he therein ventured to split the developmental process of Liao ceramics into two periods. In this context, the FMM tomb at Dayingzi, Inner Mongolia³⁰, functions as the representative of the earlier period; the XSW tomb³¹ at Qinheimen and the XXZ tomb at Jinxi, Liaoning province³² are examples of the later period.

Subsequently, as ever more datable Liao tombs were excavated up to the 1980s, the middle period of the developing process of Liao ceramics was defined by archaeologists; it is represented by the HXM tomb at Hebei³³ and the GZX tomb at Liaoning.³⁴

During the 1970s and 1980s, advanced by the increase of unearthed Liao ceramics, the study statement of the scientific field became more detailed.³⁵ The range of topics was

28 Li Wenxin 1958a, 10-22.

29 Liaoningsheng bowuguan 1961.

30 Chen Wanli 1956a, 15-16; Zheng Shaozong 1956, 1-26.

31 Li Wenxin 1954, 163-202.

32 Yan Yu 1960, 34-35

33 Tang Yunming 1973, 276-78.

34 Zhu Zifang & Xu Ji 1983, 168-95.

35 Liang Shuqin 1981, 147-50; Feng Yongqian 1981b, 571-94; Feng Yongqian 1984b, 386-92; Li Hongjun 1983, 38-41.

enhanced, including discussions on development stages, forms, decorations, technology, and production, etc. All of these studies were influenced by Li Wenxin's groundbreaking definitions and in their entirety constituted a powerful supplement to it.

Feng Yongqian must be named as another influential scholar of Liao ceramic studies, who investigated and excavated many Liao kiln sites and tombs, and published a great number of reports on the unique findings of his investigations.

In 1978, Yongqian reinvestigated the GWYC kiln. In his respective 1984 report³⁶ he discusses its time of foundation and property, viewing it as an official kiln due to the inscriptions he discovered on firing instruments.

Scientific analyses on the clay and glaze were made by the Liaoning Ceramics Institute in the 1980s.³⁷ For the first time, the study of Liao ceramics was thus approached with the aid of modern scientific methods.

In 1983, Tong Zhuchen submitted a paper on several problems of the study of Liao ceramics to a conference on archaeological work in Khitan; it would also be included in a 1989 compilation of his most influential works. In this paper he proposes a yet sketchy chronology of Liao ceramics, mainly based on the development of the bag-shaped pilgrim flask. Furthermore, he indicates that the functions of some Liao ceramics can be deduced from wall paintings or portrait stones in Liao tombs.³⁸

Xu Pingfang, in a 1984 publication, focuses on the evolution of Liao ceramics unearthed from Liao tombs. Succinctly, he discusses the relationship between the evolution of the bag-shaped pilgrim flask and the acculturating progress of the Khitan and Han people, thus enhancing the connection between household utensils and the evolution of society from a historical perspective.³⁹

In 1984, a pioneering and authoritative book on the history of Chinese ceramics was published⁴⁰, constituting the most important and comprehensive book in this study field to date. Many experts and archaeologists on Chinese ceramics contributed to the work, among them Yan Wanzhang, who authored the chapter on Liao ceramics. Wanzhang gives a complete summary of previous studies, and proceeds to present a more systematic study on Liao ceramics, including references to the heritage of artisans and kiln sites, varieties, technology, and features of the forms and decorations, etc. The publication of this book symbolized the coming of a unanimous idea of the study of Liao ceramics.

³⁶ Feng Yongqian 1984, 386-92.

³⁷ Guan Baocong & Ye Shuqing 1985; Cong Wenyu et al. 1992.

³⁸ Tong Zhuchen 1989, 78-89.

³⁹ Xu Pingfang 1984, 110-19.

⁴⁰ Zhongguo guisuanyan xuehui 1984.

Guan Baocong is another important scholar of the study of Liao ceramics, known to have headed the recovery project of Liao ceramics at the Liaoning Ceramics Institute. In the 1980s, he investigated most of the Liao kiln sites in Inner Mongolia and Liaoning province, obtaining numerous shards and for the first time analyzing the glaze and clay of Liao ceramics with the aid of modern scientific methods; his results were widely used in later studies.⁴¹ Based on these scientific analyses and his artistic researches on Liao ceramics, Guan Baocong performed restoration on ancient Liao ceramics and created the modern art of Liao ceramics.⁴²

Discussions on special forms of Liao ceramics were equally popular during the 1980s. Particular attention was paid to aspects of bag-shaped pilgrim flasks, ranging from the definition of the name to the analysis of its function, from the study of its typology to the research of its evolution.⁴³ Among the other forms examined were the dragon-shaped ewers of the Liao dynasty, researched in 1986 and 1987 by Sun Ji⁴⁴ and Mok Kar Leung Harold⁴⁵. In 1986, Li Hongjun redefined the warm basin (Nuanpen in Chinese)⁴⁶ as the based plate⁴⁷; yet, in 1996, it was renamed by Liu Fengzhu to brush-wash basin.⁴⁸ Actually, it is a part of the combination of inkstone and brush-wash basin, and this part works as the latter.

The most important catalog book of this period was the 1961 *Selection of Liao Ceramics*⁴⁹, a directory of Liao ceramics collected by the Liaoning Provincial Museum. It contained 107 plates, most of which had never been published before, thus constituting the grounds for later studies.⁵⁰

1.4.2.3.2 Japanese Publications

As mentioned before, large quantities of Liao ceramics had been brought to Japan and some Western countries during the first half of the 20th century (i.e. the first period of Liao ceramic studies). From the 1950s to the 1980s, the study of Liao ceramics continued to be pursued by the Japanese.

41 Cong Wenyu et al. 1992; Guan Baocong & Ye Shuqing 1985.

42 Guan Baocong et al. 1981.

43 Li Yufeng 1989b, 195-200.

44 Sun Ji 1986, 74-78.

45 Mok 1987.

46 It was referred to as a warm basin by Li Wenxin in an earlier study.

47 Li Hongjun 1992, 140-42.

48 Liu Fengzhu 1996, 133-34.

49 Liaoningsheng bowuguan 1961.

50 Liaoningsheng bowuguan 1961.

In 1955, Kuroda Genji's *Ceramics of the Liao and Jin Dynasty* was published in the 10th volume of the *Catalogue of World Ceramics*.⁵¹ In 1958, Kuroda Genji and Sugimura Yuzo edited *Ceramics of the Liao Dynasty*, which belongs to the series of the Corpus of Ceramics, published by Beibiyousha.⁵² These two books were among the more important publications of the 1950s, as they contain many reproductions of Liao wares collected by the Japanese.

Sugimura Yuzo published his work on Liao ceramics, *Ceramics of Liao Dynasty*, in 1974, contributing to an extensive pottery book series.⁵³ The work, which is arguably the most important analysis of Liao ceramics in Japanese collections, contained 84 plates and 24 illustrations of Liao ceramics, most of them collected in Japan. Yuzo discussed aspects of the historical context of the Liao dynasty, the discovery of Liao ceramics in Liao tombs and kiln sites, the features of Liao ceramics, etc.

In the same year, Mino Yukata published a general study on Liao ceramics.⁵⁴

Tamura Jitsuzo differentiated between the Tang-Song and the Liao-style of Liao ceramics in 1977, specially focusing his discussion on the bag-shaped pilgrim flask, the chicken-leg vase, the long-neck vase, and three-colored ceramics. Furthermore, he introduced shards collected at Liao kiln sites and Qingling (the merge name of the mausoleums of the Shengzong, Xingzong and Daozong empires).⁵⁵

In 1981, featured in volume 13 of the series on *Ceramic Art of the World* - a publication concerning Chinese ceramics of the Liao, Jin, and Yuan Dynasties - was Mikami Tsugio's preliminary division of the development process of Liao ceramics into four phases.⁵⁶ However, due to the limited number of unearthed materials, Tsugio failed to give an in-depth explanation of the devolution patterns of these periods.

In 1986, an important catalog of Liao ceramics⁵⁷ was contained in the series *Corpus of Chinese Ceramics* by the Japanese publisher Binobi (Kyoto). It itemizes 166 pieces of Liao ceramics unearthed and collected in China. The Chinese scholars Yan Wanzhang and Guan Baocong contributed articles to the book, discussing several aspects of Liao ceramics, such as form, decoration, kiln, technique, inscription, recovery, etc. Seeing as the work

51 Kuroda Genji 1955.

52 Kuroda Genji & Sugimura Yuzo 1958.

53 Sugimura Yuzo 1974.

54 Mino Yutaka 1974, 250-51.

55 Tamura Jitsuzo 1977b.

56 Mikami Tsugio 1981a, 43-169.

57 Shanghai renmin meishu chubanshe 1986.

comprises the majority of all relevant Liao ceramics unearthed before the 1980s, it represents a basic catalog for scholars of this scientific field.⁵⁸

During this research period (1950s-1980s), Japanese scholars, too, put forward a number of articles specifically concerning aspects, such as forms, decorations, and kilns of Liao ceramics.

For instance, in 1954 and 1987 respectively, Saito Kikutaro⁵⁹ and Hasegawa Michitaka⁶⁰ published articles on the chicken-leg vases of the Liao and Jin dynasties.

Furthermore, Hasegawa Michitaka put forward an outstanding article on the bag-shaped pilgrim flask in 1978, based on unearthed materials from Liao tombs.⁶¹

In 1973, Kuroda Genji published his report on investigative field work at GWYC kiln sites.⁶²

In the same year, Mikami Tsugio presented a case study of the ceramics fabricated at the GGT kiln site.⁶³

In brief, Japanese scholars continued to play an important role in the study of Liao ceramics during this period of research; however, while their publications - mainly catalog books - contained articles by renowned scholars and inspired many a later study, the contributions often remained perfunctory.

1.4.2.3.3 Publications in Western Languages

Ceramic historians of the western hemisphere had become interested in Liao ceramics from the 1960s onward, and over the following two decades the majority of them published their findings on the field in English.

Among the more important of these western publications were those by Jan Wirgin and Mino Yutaka. Wirgin was the first to write an English article on Liao ceramics in 1960, giving a general introduction to forms and decorations; "*Some Notes on Liao Ceramics*" was included in *Bulletin of the Museum of Far Eastern Antiquities*, no.32, 1960⁶⁴.

Mino Yutaka's "*Some Aspects of the Development of Liao Dynasty Ceramics*" was published in *Oriental Art*, vol.17, autumn, 1971⁶⁵, presenting a specific discussion of several pieces

58 Shanghai renmin meishu chubanshe 1986.

59 Saito Kikutaro 1954.

60 Hasegawa Michitaka 1987, 38-57.

61 Hasegawa Michitaka 1978.

62 Kuroda Genji et al.1973,241-43.

63 Mikami Tsugio 1973, 5-20.

64 Wirgin 1960, 25-46.

65 Mino Yutaka 1971, 245-51.

of Liao wares selected by the author. By then, Liao ceramics had irrevocably become a substantial part of the study of Chinese ceramics.

In 1973, Mino Yukato put forward one of the most influential Western publications to date, *Ceramics in the Liao Dynasty*. In this catalog book of a 1973 New York exhibition, the itemized ceramics are exhibits compiled from western private and museum collections.

Mok Kar Leung Harold wrote his M.Phil thesis on Liao ceramics in 1985⁶⁶, and despite the fact that it has never been published, it still represents the very first comprehensive study on Liao ceramics in the English language.

1.4.3 1990s-2000s

1.4.3.1 Liao Kiln Sites

In contrast to previous works, which were limited by the ranges of investigations, Chinese archeologists began to scientifically excavate several kiln sites from the 1990s onward.

Accordingly, in 1991, 1993, and 2005, the LQW kiln sites in Beijing were uncovered by the Beijing Cultural Relic's Research Institute.⁶⁷

The Shanxi Archaeology Institute unearthed the JZY kiln sites and some kiln sites of the Tang dynasty in 1997.⁶⁸

The Inner Mongolia Archaeology Institute and the Chifeng Municipal Museum excavated the GWYC kiln sites in 1995, 1996, and 1998, clearing an area of 550 square miles; however, the unearthed materials remain to be organized.⁶⁹

1.4.3.2 Liao Tombs

A large number of Liao tombs was scientifically cleared out during this period, and correspondingly criminal diggings were more rampant than ever before, showing a surge of legal and illegal attention paid to the nomadic Liao culture, and in extension, to its ceramics.

In the appendix of this study, thousands of unearthed Liao ceramics are listed in the Tables 24 to 51. Due to the great extend of this listing, it is quite possible that some pieces have been omitted and that various degrees of illegal disturbances of tombs have been unknowingly included.

66 Mok 1985.

67 Beijingshi wenwu yanjiusuo 2002.

68 Ren Zhilu & Meng Yaohu 1998; Ren Zhilu 2000,42-44.

69 Guo Zhizhong & Su Dong 2005, 14-29.

The distinct burial customs of Liao stipulated that ceramics be used as funeral objects. This fact accounts for a higher appearance of ceramics in Liao tombs than in Central Chinese tombs of the same historical period.

1.4.3.3 Publications

1.4.3.3.1 Chinese Publications

1.4.3.3.1.1 Articles

Beginning in the 1990s, which were marked by the discovery of ever more comprehensive archaeological materials of Liao ceramics, several scholars tackled the task of compiling typological and chronological works.

It was Qiao Liang and Yang Jing who, in 1993, divided the development process of Liao ceramics into five stages, including a period before the establishment of Liao, i.e. pre-Liao.⁷⁰

Another partition of the same development process into only three stages was put forward by Tong Zhuchen in 1989⁷¹, and later again by Liang Shuqin in 1994⁷².

In 1996, Zhang Guilian also discussed the evolution of Liao ceramics over three stages; yet these were inconsistent with the phases presented by Tong Zhuchen and Liang Shuqin.⁷³

In 1995 and 1996 respectively, Yang Jing⁷⁴ and Feng Enxue⁷⁵, put together typological works on bag-shaped pilgrim flasks.

It was during this eventful period, which abounded with ever more discoveries, that the typological and chronological works on Liao ceramics needed to be revised again and again. All of these adjustments represent a substantial groundwork for later studies.

Several discussions about aspects of related ceramics unearthed from Liao tombs were also put forward, and are briefly listed below.

In 1994, Yu Yongbing focused his attention to Liao, Yue, Ding, and Qingbai wares which had been discovered in Liao tombs.⁷⁶

In the same year, Qi Honghao and Huang Xiuchun, proposed definitions of Ding white wares from Liao and white wares unearthed at Beijing.⁷⁷

70 Qiao Liang & Yang Jing 1993, 382-93.

71 Tong Zhuchen 1989, 78-89.

72 Liang Shuqin 1994, 30-41.

73 Zhang Guilian 1996.

74 Yang Jing 1995b, 632-39.

75 Feng Enxue 1996, 35-42.

76 Yu Yongbing 1994.

A significant attempt on defining Liao white wares was made by Li Hongjun in 1997.⁷⁸

In 1998, Xie Mingliang proposed an in-depth description of Yue and Yaozhou wares unearthed from Liao tombs.⁷⁹

Likewise, Peng Shanguo discusses Yue, Yaozhou, and Qingbai wares unearthed from Liao territory in his 2003 book.⁸⁰

In 1992, Chen Yaocheng analyzed the glazes of Liao ceramics excavated from the LQW kiln sites and subsequently proclaimed that evidence of the use of borax in ceramics existed in shards of Liao three-colored wares.⁸¹

Firing instruments and loading methods of the LQW kiln sites are examined in the works of Liu Lanhua (1995)⁸² and Huang Xiuchun (2000)⁸³.

Peng Shanguo and Guozhizong presented a tentative study on the firing and loading technology of GWYC kiln sites in the year 2000.⁸⁴

In 1992, Feng Yongqian outlined four varieties of Liao ceramics, i.e. porcelain, glazed pottery, unglazed pottery and tile⁸⁵. Notably, the latter two categories had been ignored in former studies, as they do not strictly represent Liao ceramic products.

Li Hongjun reviewed characteristics of Liao ceramics in the context of forms, decorations, and aesthetics in 1994.⁸⁶

Additionally, a number of case studies of Liao ceramics unearthed from special tombs and areas appeared.

Among these were the case studies of Peng Shanguo (1998)⁸⁷ and Chen Kelun (2000)⁸⁸, concerning ceramics unearthed from the YLYZ tomb.

77 Qi Honghao et al. 1994.

78 Li Hongjun 1997.

79 Xie Mingliang 1998.

80 Peng Shanguo 2003.

81 Chen Yaocheng 1992, 317-21.

82 Liu Lanhua 1995b.

83 Huang Xiuchun 2000.

84 Peng Shanguo & Guo Zhizhong 2000, 41-5.

85 Feng Yongqian 1992.

86 Li Hongjun 1995a, 108-15.

87 Peng Shanguo 1998b, 72-3.

In 1994, Liu Li presented a survey of the Liao ceramics unearthed from the Lingyuan area of Liaoning province.⁸⁹

1.4.3.3.1.2 Books

A premium excavation report on the LQW kiln was published in 2002⁹⁰. It illustrates numerous examples of finds, including intact pieces, as well as fragments and shards with corresponding drawings of the presumed shape of the complete pieces. Moreover, the work contains findings on the production of ceramics during the Liao dynasty and the kiln site itself.

In 2003, Lu Jing publicized a comprehensive study on Liao ceramics. Based on the meticulous typological and chronological analysis of material unearthed from Liao kiln sites as well as on on-site investigations, Lu continued her studies with focus on a number of museum collections and private sources.⁹¹

In the same year, Peng Shanguo published his doctoral dissertation on the study of unearthed ceramics from Liao territory, a work concerning not only Liao ceramics, but also related ceramics excavated in the same area.⁹²

In 2004, an exhibition catalog on the artistic legacy of the nomadic Khitan culture was published by the Art Museum of the Chinese University of Hong Kong, edited in Chinese and English. The section on utensils contained the first publication of numerous pieces of Liao ceramics from museums and several private collections.⁹³

1.4.3.3.2 Japanese Publications

Yuba Tadanori includes mention of three-colored Liao ceramics in his 1995 book on Chinese three-colored ceramics.⁹⁴

Between 2001 and 2004, Imano Haruki conducted a series of studies of Liao kiln sites and tombs⁹⁵ in which Liao ceramics played an important role. Haruki publicized an article on

88 Chen Kelun 2000.

89 Liu li 1994b, 104-9.

90 Beijingshi wenwu yanjiusuo 2002.

91 Lu Jing 2003.

92 Peng Shanguo 2003.

93 So 2004.

94 Yuba Tadanori 1995.

95 Imano Haruki 2001-2004.

Liao kiln sites in 2001⁹⁶ and in the following year put forward a paper on the Liao ceramics excavated from Liao tombs.⁹⁷

In the year 2005, Kazuo Toyomasu investigated several Liao kiln sites, including the SJY and GWYC kilns of Inner Mongolia, the LQW kiln in Beijing, the GGT kiln in Liaoning, and other related kiln sites in Central China. In the following year, he published investigation reports on these kiln sites, and proclaimed his findings on connections between ceramics of China, Korea, and Japan.⁹⁸

1.4.3.3.3 Publications in Western Languages

The German scholar Hannelore Eisenhofer-Halim published her 1996 work on Liao ceramics in her mother tongue.⁹⁹ The book presents a relatively comprehensive introduction to Liao ceramics, but more importantly, it conveys a western archeological perspective on the field of Liao ceramic studies.

An exhibition on Liao culture, "*Gilded Splendor: Treasures of Chin 's Liao Empire (907 - 1125) Touring Around the World*", was installed on different locations between 2006 and 2007, namely at the Asia Society Museum in New York (5 October - 31 December, 2006), at the Museum für Ostasiatische Kunst in Cologne (27 January - 22 April, 2007), and at the Museum Rietberg in Zurich (13 May - 15 July, 2007). Over 200 recently excavated objects from Inner Mongolia were put on display, revealing the complex cultural and religious legacy of the Khitan and the Kithan reign over China during the Liao dynasty. Curator Hsueh-man Shen edited the exhibition catalogue book which also featured a number Liao ceramics.¹⁰⁰

96 Imano Haruki 2001.

97 Imano Haruki 2002, 21-42.

98 Kazuo Toyomasu 2006.

99 Eisenhofer-Halim 1996.

100 Shen Hsueh-man 2006.

CHAPTER 2 THE ARCHAEOLOGICAL DISCOVERY OF LIAO CERAMICS

2.1 FINDS FROM DIFFERENT KILN SITES

To date, archaeological excavations and investigations have located the majority of Liao kiln sites in, or in the proximity of one of the five capitals of the Liao Empire (**Map 5**). This clustering of the production facilities is explained by the fact that the administrative centers in their concomitant function as economic hubs had a great demand for ceramics. Namely, these kilns are: the Shangjing (SJY) kiln, the Nanshan (NSY) kiln, and the Baiyingele (BYGL) kiln at Lindong, Balin Left Banner, Inner Mongolia (near the Supreme Capital); furthermore, the Gangwayaocun (GWYC) kiln at Chifeng, Inner Mongolia (near the Central Capital Ningcheng); the Gangguantun (GGT) kiln at Liaoyang, Liaoning (near the Eastern Capital); the Longquanwu (LQW) kiln, the Xiaoshuiyu (XSY) kiln, and the Cijiawu (CJW) kiln at Beijing (near the Southern Capital); and finally, the Jiezhuang (JZY) kiln at Hunyuan, the Huairen (HRY) kiln at Huairen, and a kiln at Qingciyaocun (QCY), Datong, Shanxi province (near the Western Capital). From these archaeological discoveries it can be deduced that Liao kiln sites were installed specially to meet the daily needs of the Liao people for ceramic wares. Surrounding the tracts were abundant sources of clay, fuel, and water, all of which are substantial for the production of ceramics.

A detailed discussion of each of these kiln sites will be conducted in the following. Unfortunately, the production site at Datong must be excepted from this, as information on it is restricted to the knowledge of its operating time from the Late Liao to the Jin dynasty (1115-1234), and its favored pieces of production, i.e. coarse vessels like black-glazed chicken-leg vases.¹⁰¹

Three more kiln sites can be attributed to the Liao dynasty: the Daguantun (DGT) kiln at Fushun (**Map 11**), the Liuli kiln at Beijing, and the Longhua (LHY) kiln at Chengde. The Japanese were the first to inspect the DGT kiln in the early years of the 20th century¹⁰², predominantly locating shards of black-glazed, brown-glazed and teadust-green-glazed vessels which had once been intended for daily use. It is important to mention, however, that besides said make and function, hardly anything is known about the Liao products of Daguantun.

While the Liuli kiln at Beijing was discovered to have mainly produced architectural accessories¹⁰³, all that can be said with any certainty about the LHY kiln is that a Liao kiln site

101 Shanxi Yungang guji baoyang suo 1958,72; Zhongguo guisuan yan xuehui 1982, 70.

102 Sugimura Yuzo 1937, 68-69.

103 Wenwu bianji weiyuanhui 1984, preface.

existed at Chengde.¹⁰⁴ A detailed understanding of the tract, however, can only be achieved once an archaeological report on it will be published.

2.1.1 The Gangwayaocun (GWYC) Kiln

2.1.1.1 General Introduction

The GWYC kiln site is situated at Gangwayao village, Houtougou township, Chifeng city, Inner Mongolia, in the narrow valley of the upper reaches of the river Banzhijian, 70 kilometers west of Ningcheng (Dading, the Central Capital of Liao)(**Map 6, Pl. 1**). It covers an area of approximately 2 square kilometers, from Huangtukeng village in the east, over Gangwayaoat village at its center, to Shuiquan village in the west. While the northern part of the tract rests on undulating hills, it is bordered by the Majianan Mountain in the south. The Wutaitu River winds along its foot to pour into the Banzhijian River (a tributary of Yingjin River) farther to the east. The area abounds in coal resources and quality clay minerals. In addition, the rich water sources of ground and river water grant that the natural environment of the GWYC site is highly suitable for a ceramic industry.

The kiln was discovered by Kodama Shigeo, Uehara Shinobu, and Saito Takeichi in 1943, and was revisited in the following year by Kuroda Genji, Koyama Fujio, and Li Wenxin. After the end of the Sino-Japanese War, Chinese archaeologists also repeatedly investigated the site.

With twenty to thirty kilns located in the area, GWYC is undoubtedly the largest and most important kiln site which has been discovered to this day. Its products are of a profuse variety and the tract across which ceramic shards are scattered covers approximately 1 square kilometer.

Moreover, there are pillars inscribed with Sanskrit (Buddhist inscriptions) to be found, as well as Liao-type bricks and tiles which are decorated on their broadsides with molded animal masks (**Pl. 2**). Among the GWYC kilns' remains and shards are fragments of several Khitan-style ceramic forms which verify its status as a Liao kiln; counted among these are the bag-shaped pilgrim flask (cock's-comb), the long-neck vase, the chicken-leg vase, the oblong-lobed dish, etc.

The products unearthed on location comprise white wares (**Pl. 3, Pl. 4, Pl. 5**), three-color-glazed wares, monochrome green-glazed and yellow-glazed wares (**Pl. 6, Pl. 7**), teadust-green-glazed and black-glazed wares (**Pl. 8, Pl. 9**), as well as a number of Cizhou-type sgraffito wares (**Pl. 10, Pl. 12**).

The GWYC kiln is estimated to have started its operation at around the reigns of the emperors Taizong (927-947) and Shizong (947-951), and to have been in use until after the end of the Liao dynasty. Many existing Liao ceramics can be attributed to it, particularly those unearthed

104 Qinggongyebu taoci gongye kexue yanjiusuo 1983, 322.

in or near Chifeng city, e.g. early pieces recovered from the FMM tomb at Dayingzi, Chifeng, Inner Mongolia, and the late examples from the XLZZ tomb at Ningcheng, Inner Mongolia.¹⁰⁵

2.1.1.2 Kilns and Technology

It can be deduced from the site's profile, which was flushed by the river, that the GWYC kilns are arranged from east to west over a length of approximately 100 meters. Their roofs barely rise above the ground, the highest elevating to only 50 centimeters. The regular kiln chamber is of a round shape which measures between 3 and 10 meters in diameter (**Fig. 1, Fig. 2**). The accumulative layer left inside the kiln chambers adds up to approximately 1 to 2 meters. Large quantities of ceramic products, predominantly coarse, white-glazed stoneware and teadust-green-glazed chicken-leg vases, were stacked on the flat-bed-shaped furnace siege of the chamber.

The SQG (Shuiquangou) kiln site is situated on a hillside, 0.5 kilometers south of the Shuiquan village. At least a dozen of kilns were exposed from the ground, revealing an arrangement from north to south. Notably, the kiln chambers are small in size and sometimes dragon-shaped. The site had been repeatedly investigated by scholars in the 1970s and 1980s¹⁰⁶, but it was only in the years 1995, 1996, and 1998, that the Inner Mongolia Research Institute of Cultural Relics and Archaeology and the Chifeng Municipal Museum scientifically excavated a total area of approximately 550 square meters.¹⁰⁷

The project delivered an extensive output and evidenced that different ceramic products were fired in their own particular kilns. For instance, the disparate firing temperatures for white stonewares, three-color-glazed, and monochrome-glazed earthenwares made it impossible to simultaneously fire the different ceramics in one kiln.

In accordance with varying firing techniques, two different methods of kiln construction can be observed. One kind of kiln consists exclusively of fire bricks, while the other is made of a combination of fire bricks on the inside and bricks (or stones) on the outside. The scope of kiln instruments mostly contains saggars, support spurs, support circles, and bedders (**Fig. 3, Pl. 14-Pl. 17**). When stacked, white-glazed bowls were normally separated and supported by three or four round-shaped clay-spurs (**Pl. 18**). As a result of the simultaneous firing of ceramic products and support tools, they frequently stuck to each other when they were taken from the kiln (**Pl. 20**) and had to be broken apart. This procedure often left three to four scars on the bottom of a vessel, seriously affecting its aesthetic value (**Pl. 19**). Accordingly, a multitude of waste products was also discovered at the SQG kiln site, consisting of stacks of support spurs and ceramics which could not be separated, some of them counting up to a dozen clotted bowls (**Pl. 20**). Further finds included a number of products with unglazed rims (Chinese: mangkou) which are representative of a technique of upside down loading

105 Zheng Shaozong 1956, 1-26; Li Yiyou 1961, 44-49.

106 Feng Yongqian 1984, 393-407; Wang Jianguo 1987.

107 Wang Dafang & Guo Zhizhong 1996; Guo Zhizhong & Liu Bing 1998; Liu Bing 1998.

supported by circle-shaped instruments (**Pl. 21**). It is, in fact, a highly advanced loading method, developed by artisans of China proper, which helped to avoid the firing defects mentioned above. The circle-shaped instrument, which I could identify during my own investigation of the site, can be considered evidence for the influence of the Ding kiln of China proper on GWYC (**Pl. 21**).

The production process of three-color and monochrome lead-glazed earthenware ran through five phases: the forming, the coating with white slip, the high-firing into biscuit, the glazing of the biscuit with different lead colors, and a final bout of low-firing. Popular among the support instruments employed during firing were triangular one-side spurs made from the same white clay as the earthenware. They generally left three scars on the ceramics vessels (**Pl. 22**). On account of the flowing direction of the glaze and the glaze left on the spurs, it may be assumed that utensils like bowls and dishes were supported upside down and stacked on the spurs during the firing process (**Fig. 4**). Apart from the triangular one-side spurs, some triangular double-side spurs (**Fig. 4**) were also discovered at GWYC; however, their specific function still needs to be proved.

Furthermore, bobbin-shaped firing instruments made from coarse, white clay and measuring approximately 5 cm in length (**Fig. 5**), were unearthed from the grounds. Such tools were applied as lateral support for tall vessels like chicken-leg vases (**Fig. 5**), and left round or ovoid scars on the ceramics' shoulders (**Cat. 553**).

Also scattered on the grounds were large quantities of cylindrical support instruments (**Pl. 23**). With diameters ranging between 7 and 10 centimeters, these devices bear the residues of a brown or a teadust-green glaze on their surfaces. Notably, one side of the cylinders is flat while the other one is broken.

2.1.1.3 Varieties of Ceramics

2.2.1.3.1 White Stoneware and Porcelain

White wares are the main products of the GWYC kiln. They can be divided into two types.

On the one hand, there are porcelain products (**Pl. 5**) of very fine quality which bear no white slip under the transparent glaze. They are high-fired to the point of translucency and come very close in quality to the Ding and Xing wares of China proper.¹⁰⁸ However, their numbers are limited.

On the other hand, stoneware of a far rougher make (**Pl. 3, Pl. 4**) can also be found at GWYC. The body of this kind of product is sandy, slightly yellow, and sometimes, particularly in the case of large vessels, interspersed with dark flecks. The surface texture of the broken section shows that the body is not as lustrous as that of some white wares from other kilns. While the latter are slipped and covered in a milky white bright slip, the glaze applied to most of the coarse, large GWYC vessels is of a heavy yellowish opaque muddy white color.

108 Feng Yongqian 1984b, 386-392.

In the majority of cases the firing support tools in the saggars were three-footed, round-shaped spurs; but small, fire-resistant clay balls were also employed, often leaving three spur marks on the interior bottom of the vessels.

The ceramic forms most commonly produced at the GWYC kiln are bowls (**Pl. 24, Pl. 39**), ewers (**Pl. 34**), jars (**Pl. 32**), vases (**Pl. 33**), and boxes (**Pl. 37**). Additionally, some chessmen were discovered on-site (**Pl. 26**), as well as a number of toys like dogs, horses, and ocarinas in the shape of animal heads.

The decorative motifs most often applied to GWYC ceramic vessels are the phoenix, the fish, the lotus, the peony, clouds, water-waves, and scrolling patterns. They are incised, carved, impressed, or molded (**Fig. 6**) upon the potteries. As these decorations are extremely similar to the ones found on Ding wares, it is assumed that Ding-kiln potters initiated the work at GWYC.

Aside from ceramics influenced by Ding and Xing wares, many other GWYC products showed strong touches of typical Cizhou decorations, e.g. sgraffito or paintings in brown or black. The best example of Cizhou-style GWYC ceramics are jars decorated with the sgraffito technique (**Pl. 10**) which have ever been discovered at Gangwayao village, the site of the GWYC kiln.¹⁰⁹ While several shards incised with floral designs on an iron-black or dark-brown ground are closely related to the sgraffito jars, they still underwent a more innovative treatment. Those Cizhou-style ceramics painted in brown and black with iron oxide pigments (**Pl. 11**) are mainly decorated with simple designs, e.g. an outline on the edge of the mouth, repeated straight lines, repeatedly crossed, straight lines, daubs, or some dotted floral motifs of plum blossoms and grass blades.

2.2.1.3.2 Three-color and Monochrome-glazed Earthenware

Low-fired lead-glazed earthenwares occur in fewer quantities than white stonewares. Typically, their bodies are of a pinkish color and somewhat soft.

During the process of glazing, the naked bodies of the ceramics were first covered with white slip and high-fired into biscuit (**Pl. 25, Pl. 28, Pl. 29, Pl. 30, Pl. 36**), before a monochrome or polychrome lead glaze was applied.

Three-clawed spurs were used to support the vessels during the firing process, causing the pieces to sustain three small, round spur scars at their center (**Fig. 4**). Three-color lead-glazed earthenwares, as well as green or yellow monochrome lead-glazed earthenwares, were fired in the same kilns; in the process the bodies were high-fired before the application of the glazes and a subsequent finishing bout of low-firing.

The earthenwares mainly occur in the shapes of round dishes, square dishes, bowls, and bag-shaped pilgrim flasks (**Pl. 40**); other forms include long-neck vases (**Pl. 38**), phoenix-head vases, inkstones (**Pl. 30, Pl. 36**), ewers (**Pl. 28**), oblong-lobed dishes, ocarinas (**Pl. 25**) etc. The

109 Feng Yongqian 1981, 65-70.

discovery of shards of bag-shaped pilgrim flasks and phoenix-head vases at GWYC has been of particular importance. The bag-shaped pilgrim flasks, the first two shards of which were found in 1944, followed by more finds of Chinese archaeologists in the 1990s (Pl. 40), are very similar to bag-shaped pilgrim flasks unearthed from Liao tombs. Consequently, most existing bag-shaped pilgrim flasks can be attributed to the GWYC kiln with some certainty. The phoenix-head vases and oblong-lobed dishes, also very typical Liao shapes, are likewise believed to have been produced at GWYC as corroborating evidence has been found at the kiln sites.

The majority of three-colored polychrome lead-glazed earthenwares are decorated with molded designs, a characteristic of Liao lead-glazed wares. The most frequent motifs are the phoenix, the fish, the lotus, the peony, human figures, water-waves, and some scrolling patterns (Fig. 6). Furthermore, numerous molded instruments have also been unearthed at the GWYC kiln site (Pl. 42, Pl. 43).

2.2.1.3.3 Black- (Brown-, and Teadust-green-) Glazed Stoneware

Black-glazed stonewares were discovered in fewer quantities than white and three-colored earthenwares at GWYC. Among those numbers unearthed, chicken-leg vases occupy the dominant position; other finds comprise small parts of bowls, dishes, and jars (Pl. 8, Pl. 9).

Due to divergent firing temperatures, the glazes of single chicken-leg vases, with their tall slim shape and coarse, specked bodies, show different color depths. The tones range from black to brown as well as from a grayish-green, reminiscent of teadust, to a grayish-yellow.

2.1.1.4 Inscriptions

Only few inscribed fragments have been discovered at the GWYC kiln site. According to statistics figured up from several investigations, three to five samples were incised with a guan (official) mark¹¹⁰. This particular character is small and coarsely etched into the vessel, usually on its bottom, inside the ring-foot. Furthermore, instances of the guan (official) and xinguan (new official) marks have been found craved into the side surfaces of cylindrical firing instruments (Pl. 44). The shoulders of chicken-leg vases are often incised with such Chinese character marks as “Li Zao”, “Bao Zhu”, or “Zhai Xiu” etc, which are likely to denote the names of the producers or traders. Another kind of inscription observed on the shoulders of

110 Guan is the pronunciation of the Chinese character 官, which means official.

chicken-leg vases are Khitan characters¹¹¹, such as “Qian ... year” (i.e. “Qiantong such-and-such year”) (PI. 343-PI. 348)¹¹², usually indicating the vessels’ production date.

2.1.1.5 Property

Concerning the propertyship of the GWYC kiln site, Jin Yufu, during the mid-fifties of the 20th century, cited an information recorded in ancient Chinese literature to maintain that the Liao official kiln should be located at Chifeng city, and furthermore, that white wares discovered in the FMM tomb at Dayingzi, Chifeng and dated to 959, were products of the Liao official kiln.¹¹³ Evidently, Jin Yufu’s conclusion that all white wares bearing the guan (official) mark, as well as other related white wares, were produced by that official kiln is no longer tenable. It was first objected by Chen Wanli, and eventually overthrown by an increased understanding of ceramics which bear the guan mark.¹¹⁴ Song and Yuan historical records state that an “officer for fine wares” (ciyao guan) was established by the Liao emperor and that there was an “official kiln” (guan yao). Furthermore, a Yuan dynasty enumeration of “official kiln officers” (guan yao guan) states that a kiln existed under Liao control at a place identifiable as Songshanzhou, the site of a walled town not far from the Chifeng kiln described before. This evidence is in favor of the argument that this place was indeed the official kiln of the Liao and the source of the marked fine white wares. It ought to be mentioned that the use of the guan mark had previously been introduced on Ding wares, and that it remains uncertain whether it was the Liao emperor or one of his confreres, the rulers of the 10th-century states in northeastern China, to first to adopt this method of controlling and taxing the manufacture of fine pottery in his territory. Nevertheless, as evidenced by a guan-marked saggar found at the premises in 1975 (PI. 44), the GWYC kiln at Chifeng is that Liao official kiln mentioned in Chinese documents.¹¹⁵

2.1.2 The Shangjing (SJY) Kiln

2.1.2.1 General Introduction

111 The Khitan used two functionally independent systems of writing, known as the large script and the small script. While the former was derived from Chinese (Han characters), the latter was reportedly created by the scholar Diela ca. 925 AD, and is said to have been inspired by the Uyghur alphabet. Both scripts were connected to the spoken language of Khitan. Despite the fact that there are several clues to its origins pointing in different directions, the Khitan language is most probably Mongolic, and its agglutinating nature is poorly fitted for monosyllabic logographs. The small script had logographs as well as characters which were completely phonemic. The Jurchen (ancestors of the Manchu people) derived their large script in part from Khitan.

112 Neimenggu zizhiqu wenwu gongzuodui 1963.

113 Jin Yufu 1956, 1-4.

114 Chen Wanli, 1956, 15-16.

115 Feng Yongqian 1984a, 393-407.

The SJY kiln site is situated in the old city Linhuangfu of the Liao Supreme Capital Shangjing, three kilometers south of today's Lindong township, Balin Left Banner, Inner Mongolia. The Huang River flows nearby (**Map 8, Pl. 45**).

The site's expanse is rather small, stretching over approximately 80 meters from north to south, and 50 meters from east to west. It was first discovered by Yamamoto Mamoru in 1939, and investigated by Koyama Fujio in the following year. In May of 1944, Li Wenxin and Kuroda Genji performed a tentative excavation of the SJY kiln site which required a fortnight and made it possible to define its scope and scale (**Pl. 46**). Remarkably, several saggars and other firing instruments have been recovered from the premises.

As evidenced by great numbers of scattered shards and firing instruments, large amounts of varied wares appear to have been produced at this kiln site during a short period of time. The quality of its products is notably superior, heavily influenced by both Ding and Xing wares of China proper, and directly supervised by Liao.

Koyama Fujio and Li Wenxin took different positions where the duration of the SJY kiln was concerned.

Koyama believed that the operation of the kiln started with the reign of the Emperor Taizong (927-947), and that its closure coincided with the fall of the Liao dynasty.¹¹⁶ However, such an estimation of the running period appears to be too long.

Li Wenxin pointed out that the small scale of the kiln indicates that it could only have been operated over a short stretch time, i.e. approximately two years. Judging from a copper coin cast with the characters "Yuanfengtongbao" that was found in the SJY kiln, Li states that the kiln may have begun operation at around 1087.¹¹⁷

However, taking into account the shards carrying the guan mark, Li's conclusion is neither absolutely convincing: the date of white wares bearing this inscription has recently been traced back to an earlier point in time, probably not later than the early 11th century. The above-mentioned guan-marked lugged vase unearthed at Shangjing, also appears in a form prevalent during the Early Liao dynasty. Moreover, it is imprudent to base the dating of the kiln merely on the finding of the Yuanfengtongbao coin, considering that the circumstances under which it was left on the kiln site are yet unknown. Consequently, it appears most appropriate to connect the SJY kiln to the Early Liao dynasty.

2.1.2.2 Kilns and Technology

The shape of the kilns of SJY is hemispherical. The firing tools located on-site comprise saggars, spurs, and circular support instruments (**Pl. 47, Fig. 7, Fig. 8**). Notably, the saggars appear in two different forms: one is intended to hold stacked bowls and dishes in place and has a

116 Koyama Fujio 1962, 69-81.

117 Li Wenxin 1958b, 97-107.

hollow, cylindrical shape with a flat bottom. The other form displays a circular bottom and, depending on the height of the vessels, can contain three to five bowls or dishes (**Fig. 7**). The spurs occur in three forms, i.e. in trigeminal, round, and triangle shapes, each equipped with three prongs to fixate the vessel (**Fig. 8**). The circular support instrument, which was invented by the artisans of the Ding kiln of China proper, is the most important tool for the upside down loading method.

2.1.2.3 Varieties of Ceramics

The SJY kiln is known to have fabricated three varieties of ceramic products: white wares, black-glazed wares, and green-glazed wares.

2.1.2.3.1 White Stoneware and Porcelain

White wares constitute the largest variety among the products of the SJY kiln.

The bodies of white wares occur in two different variations. One is a purely white high-fired porcelain ware of very fine quality which bears no white slip under the transparent glaze layer (**Pl. 48**). It undoubtedly represents the optimum product among Liao ceramics, and is regarded to show a close resemblance to Ding and Xing wares of China proper. The body is of a fine white color; however, in some cases it appears somewhat darker and slightly lustrous, with a glassy appearance in the break. The other variation consists of thicker, coarser stoneware bodies (**Pl. 49**). Some of these large vessels bear grayish-black impurities in their white bodies, a circumstance explained by the fact that they were intended for ordinary use only, diminishing the degree of selection and the handling of the clay.

The thinly applied transparent glaze is rather pure, and of a warm white hue. In some cases it may carry a yellowish sheen, or have accidentally been given a light-green color. The latter is caused by an imperfectly controlled oxidizing firing atmosphere which results from a change of the wood used as fuel.

The ceramics of SJY occur in various shapes (**Fig. 9**). Traditional Chinese vessel types, such as bowls, dishes, vases, jars, basins, boxes, and spittoons etc. can be found, as well as distinguished Khitan vessel types preferred by Khitan people, such as the long-neck vase, the lugged flask¹¹⁸, long-handled ewers, the square dish, the oblong-lobed dish, and a dish with a marshmallow contour. The oblong-lobed dish of SJY is particularly interesting, as its fine porcelain quality and white-glazed decoration distinguishes it from most other existing examples of this vessel form which is usually confined to three-colored earthenware with molded designs.

During my investigation of the SJY site in April 2001, a white-glazed porcelain shard of a small bowl was discovered, decorated with an incised floral design (**Pl. 50**). It was of an extremely fine make and comparable to Ding wares of China proper. A corresponding whole piece of the kind is exhibited at the Liaoshangjing Museum (former Balin Left Banner Museum).

118 Wang Qing 1979, 3-14. Two shards of the lugged flask have been unearthed in the Shangjing area in 1979, which are regarded to be products of the SJY kiln.

In conclusion, it can be observed that most white wares discovered at the SJY kilns have plain surfaces, and that only a few of the pieces bear carved or incised decorations. Counted among the decorative motifs are mainly flowers; a few shards display an incised dragon motif.¹¹⁹

2.1.2.3.2 Black-glazed Stoneware

Black-glazed wares also occupy an important position among the various products of the SJY kiln, constituting the second largest group after white stoneware and porcelains (**Pl. 51, Pl. 52, Pl. 53**).

Their bodies are made from the same clay as white wares and are of an equal quality. The glaze is black and glossy, lustrous and warm, and displays green and brown reflections. Massed glaze can be seen where it was thickly applied.

The shapes of black-glazed stonewares are of little variety. Most often to be found are vases, bottles, jars, ewers, or basins. However, grayish-white stoneware tiles with a black glaze were also produced at the site, and attracted the particular attention of scholars on account of their similarity to the tiles covering the roof of the ancestral temple of the Liao Emperor Taizu at Zhuzhoucheng, near the Lindong township.¹²⁰

2.1.2.3.3 Green-glazed Stoneware

In comparison with white and black wares, the numbers of unearthened green-glazed wares are limited. While their quality is decent, it does not compare to the fine make of the white and black-glazed wares, and their hardness conveyed to the excavators a hint of an “intermediate temperature between a low and high firing”.¹²¹ Koyama Fujio, who discovered some fragments of this type, described them to be white-bodied. The SJY wares appear to be superior to most other green-glazed products discovered in Liao tombs, i.e. pinkish-buff earthenwares, of which Li Wenxin assumed that their body was not fired separately before the glazing.

2.1.2.3.4 Marbled Wares

During my 2001 visit of the SJY site, a small shard of a marbled ware was discovered (**Pl. 54**); more precisely, the fragment belonged to the mouth of a little bowl. The material is very fine and dense, and consists of a combination of yellowish-white and brown-colored clay. On the one hand, based on the features of the clay and glaze, it is very similar to the marbled ware bowls found in Liao tombs and pagodas at Liaoning and Jilin province in recent years. On the other hand, it differs from the marbled wares found at the kiln sites of Hebei province of China proper, the clay of which is looser, and the colors of which are much brighter; especially the white color which has a very pure tinge. Since the SJY kiln site has not yet been scientific excavated, this small piece of marbled ware provides a new clue to the place of production of those marbled wares found in other Liao tombs and pagodas.

119 Li Wenxin 1958b, 97-107, pl. 5:2.

120 Koyama Fujio 1962, 69-81.

121 Li Wenxin 1958b, 97-107.

2.1.2.4 Inscriptions

Oftentimes, various marks are incised on the base of a vessel¹²², representing a unique trademark of SJY wares. The eight most frequently recorded varieties of such imprints (、 、 卩、 、 、 卩、 开、 ○) have been suggested to be either records of orderings, or signatures of different ceramic workshops which had formed partnerships. Of even more importance, however, is Koyama Fujio's SJY discovery of several shards engraved on their bases with the character guan (official).¹²³ One of the above-mentioned lugged vases is an example of a vessel engraved with this mark. It is important to note that guan-marked ceramics have long constituted a problem in the study of Chinese ceramics.

2.1.2.5 Property

In 1962, Koyama Fujio proclaimed the SJY to have been an official kiln site. On the one hand, his claim was based on the striking resemblance of the black-glazed tiles found at SJY to those covering the roof of the ancestral temple of the Emperor Taizu in Zuzhoucheng; on the other hand, it rested on his discovery of several ceramic shards inscribed with the guan mark.¹²⁴

However, Li Wenxin disagreed with this position. He argued that the small scale of the SJY kiln would have made it impossible to cope with the great demand for tiles for Taizu's temple, in the remains of which over ten thousands pieces of tile have been discovered. He concludes that the SJY kiln was not an official kiln, but that it was set up either by Khitan's aristocrats or by the monks of nearby temples.¹²⁵

Nevertheless, from 1980s onward, Chinese archaeologists tended to regard the SJY kiln as an official production site, judging from the good quality of its wares and the location of the tract inside the imperial city of the Liao Supreme Capital.¹²⁶

2.1.3 The Nanshan (NSY) Kiln

2.1.3.1 General Introduction

The NSY kiln site specialized in the production of low-fired lead-glazed earthenware. The tract is located on a mountainside, about 1.5 kilometers southwest of the old city Linhuangfu of Shangjing (the Supreme Capital of Liao), at today's Lindong township, Balin Left Banner, Inner Mongolia (**Map 9**).

Unfortunately, it was severely damaged, and the kilns themselves are no longer in existence. All that remains of the ancient production site are a number of shards and kiln tools scattered

122 Li Wenxin 1958b, 97-107, pl. 5:2.

123 Koyama Fujio 1962, 69-81.

124 Koyama Fujio 1962, 69-81.

125 Li Wenxin 1958b, 97-107.

126 Zhongguo guisuanyan xuehui 1982, 314.

on the ground. It can be securely deduced from the small quantity of residue and the restricted area over which it is distributed, that the NSY kiln was of small scale and only operated for a short time. On account of evidence of lead glazing, it is believed that the kiln began to operate in the later part of the Liao dynasty and was run until around the Dakang reign (1057-1084) of the Emperor Daozong.¹²⁷

2.1.3.2 Technology

Multiple three-clawed spurs were found on the NSY grounds. These tools supported a firing technique which had also been applied before by several Tang kilns, like those at Jiaxian and Henan, and which continued to be practiced in many Song kilns, particularly in Cizhou-type kilns.¹²⁸

2.1.3.3 Varieties of Ceramics

The ceramic variety most frequently produced at the NSY kiln was low-fired lead-glazed earthenware. Defined by the color of their glazing decoration, there are polychrome lead-glazed wares as well as monochrome white-, yellow-, and green-glazed wares. The white, yellow, and green glazes were either applied together on a single vessel to produce a three-color glaze, or applied individually to give the piece a monochrome shine.

2.1.3.3.1 Three-color Lead-glazed Earthenware

The bodies of three-color lead-glazed earthenware are of a comparatively soft, pinkish material. The colors of the glazes applied to it are green, yellow, and white, none of which is particularly glossy and all of which tend to flake off easily. Many fragments should be decorated with glaze, but the glaze has completely flaked off, so that only the bare body remains. Between the body and the glaze is an intermediate layer of white slip. Three-color lead-glazed earthenwares most often appear in the shapes of dishes or basins.

These NSY products are remarkably similar to most examples of three-color lead-glazed earthenwares recovered from Liao tombs. The wares discovered at CGB11 (**Cat. 729**), CKTDS4 (**Cat. 731**), LBB (**Cat. 724**), and DSLT1 (**Cat. 727**) tombs, for instance, are believed to have been produced at the NSY kiln site.¹²⁹ Even though the NSY pieces do not quite resemble typical Liao three-color lead-glazed wares, e.g. oblong-lobed dishes with impressed designs later produced at the GWYC kiln, they still marked an advance towards polychrome decoration.

2.1.3.3.2 Monochrome White-, Yellow-, and Green-glazed, Low-fired Earthenware

Monochrome white-, yellow-, and green-glazed low-fired earthenwares are yet another product of the NSY kiln site. They possess reddish and soft bodies reminiscent of three-color pieces.

127 Zhongguo guisuanyan xuehui 1982, 316.

128 Feng Xianming 1965, 26-56; Mino Yutaka 1981, Appendix B.

129 Liaoningsheng bowuguan 1961, 109.

Their glaze is pure white and cool, applied over layer of slip. In some instances, white- or yellow-glazed pieces are adorned with a small green design which creates a nice decorative effect; this special feature is a trademark of NSY products.

Among the archaeological finds which are likely to have been produced at the NYC kiln are white- and green-glazed earthenware basins from various Liao tombs (**Cat. 741, Cat. 738, Cat. 739, Cat. 743**), the white- and green-glazed earthenware long-neck vase collection of the Tokyo Museum (**Cat. 313**), the white- and green-glazed earthenware phoenix-head vase exhibited at the Royal Ontario Museum, Toronto (**Cat. 370**), as well as several pieces of white- and green-glazed, earthenwares with incised floral designs.

2.1.4 The Baiyingele (BYGL) Kiln

2.1.4.1 General Introduction

The BYGL kiln site concentrated on the production of large, rough vessels with teadust-green or black glaze. It is located in a large field behind Bayingele village, Hadayingge township, Balin Left Banner, Inner Mongolia, about 2.5 kilometers west of the old city of Shangjing (the Supreme Capital of Liao) (**Map 9, Pl. 55**).

The tract was discovered by Li Wenxin when, during his 1944 visited of the SJY kiln site, he incidentally performed a very rough investigation in BYGL. Many of its kilns are in ruins and some are even buried underground. The area in which shards and kiln tools are scattered stretches about 300 meters from east to west, and 500 meters from north to south. In some places, the underground layer of shards measures over 1 meter. These facts show that the BYGL was a notably large-scale production site.

2.1.4.2 Kilns and Technology

According to investigation reports, three kilns of hemispheroid shape have been exposed in the southern part of the BYGL kiln site, scattered around which are red burned clay and broken fire bricks with kiln sweat. On the western side of these three kilns, two regions of accumulated crushed clay minerals have been located, amounting to a gauge of 10 centimeters. These tracts are assumed to represent the clay mineral selection regions of this kiln site. During my own 2001 investigation of BYGL, I found that said three kilns were completely destroyed; therefore, the only clues as to where the ancient kiln was once located are the broken fire bricks, the firing instruments with kiln sweat (**Pl. 56, Pl. 57**), as well as the ceramic shards scattered on the ground (**Pl. 58**).

The characteristic BYGL methods of loading were comparatively primitive, if one may judge from the custom of firing tall jars without the protection of saggars or other flame screening equipment, and of setting the vessels straight into the kiln. Nevertheless, fire-resistant clay balls or posts were placed within the vessels to prevent their collapse during firing, and bobbin-shaped kiln tools separated the stacked pieces (**Pl. 59**). Thus, there are often scars on the mouths, bases, and bodies of BYGL pieces.

2.1.4.3 Varieties of Ceramics

The products of the BYGL kiln occur in three varieties of diverse quantity.

One variety is teadust-green-glazed stoneware, predominantly in the shape of chicken-leg vases (**Pl. 60**). These vessels are thick-walled pots, the coarse, yellowish bodies of which are fired to be very hard. The glaze is of a grayish yellow-green color and commonly said to be reminiscent of teadust-green. The distinctive form of the chicken-leg vase, i.e. a small mouth, a flat base, and a tall cylindrical body, often occurred among Liao ceramics. Concerning its function, it has been suggested that it was used for fermenting milk, or that it was favored by Khitan people as it required only a little storage space in a tent.

The second BYGL ceramic variety is black-glazed stoneware (**Pl. 61**). The body of this type of vessel is the same as that of the teadust-green-glazed ware; its glaze, however, is pure black, fine and warm, but not particularly glossy. In comparison with the products of the nearby SJY kiln, the black-glazed wares of the BYGL kiln are of inferior quality and occur in smaller quantities. Among them the form of large jars is predominant, and particularly common are jars bearing two handles on their shoulders.

The third variety is white-glazed stoneware which, however, occurs only seldom (**Pl. 62**).

2.1.4.4 Property

As reflected by its relatively rough and coarse products, the BYGL kiln was a folk kiln. Its operation has been estimated to have begun roughly around the reigns of Jingzong (969-983) and Shengzong (983-1031).¹³⁰

2.1.5 The Hadayingge (HDYG) Kiln

The HDYG kiln specialized in the production of big vessels of teadust-green-glazed and black-glazed stoneware. It is located at the foot of Hadayingge West Hill, Balin Left Banner, Inner Mongolia, 5 kilometers west of the ancient Shangjing city (the Supreme Capital of Liao) (**Map 9**). Broken fire bricks, firing instruments covered with kiln sweat, and ceramic shards are scattered on its grounds. The accumulative underground layer of waste products and instruments adds up to a gauge of approximately 1 meter. Not only is the HDYG tract strikingly similar to BYGL in respect to the style of its kilns, but also regarding the varieties of its ceramics, as well as its firing and loading techniques. Apart from the predominant production of such big vessels as teadust-green-glazed chicken-leg vases, small toys in the shape of horses and camels were also made at HDYG. An example of the latter, the teadust-green-glazed camel, displayed in Pl. 63, was collected by Guan Baocong in the 1980s while he investigated on location. Unfortunately, during my own 2001 visit of the area, I had to find that the ancient kiln site had meanwhile been completely destroyed and is now a country yard.

2.1.6 The Xiaobeigou (XBG) Kiln

The XBG is a pottery kiln site, situated 1 kilometer east of Xinnong village at Sanshan township, Inner Mongolia (**Map 9**). It has been exposed by the flush of a flood to be standing on a small

130 Zhongguo guisuanyan xuehui 1982, 316.

cliff. The kiln was built from stone and measures 3 meters in diameter and 2.5 meters in height. The inside walls bear traces of burns, and covering the floor is a 30 centimeter, black and brown layer of burnt oil. Located south of the kiln site is a big pit wherein a large quantity of fine grey pottery shards can be found.

2.1.7 The Yaokengdi (YKD) Kiln

The YKD is a comparatively large kiln site, located at Huanghuagou village, Shanzuizi township, Wengniute Banner, Inner Mongolia (**Map 9**). The exposed area covers approximately 10,000 square meters; contained among the shattered shards are white-glazed porcelain firing instruments and spurs. Moreover, a number of burned charcoals have been left on the grounds.

2.1.8 The Dongshabuertai (DSBET) Kiln

Several kiln sites are contained in DSBET, namely the DBWS kiln, the SQGC kiln, the BSY kiln, and the LBYH kiln (**Map 9**). Among these, the SQGC kiln is the largest in scale, and judging from fragments scattered on its grounds, its main product was white-glazed stoneware. White- and green-glazed wares have been discovered in the DBWS kiln. The sintering temperature of the clay is relatively low and the color of the body is a pinkish white. The main forms are bowls, dishes, and basins. Trigeminal-shaped spurs were the most popular support instruments.

Numerous white- and green-glazed wares, as well as monochrome white-glazed wares recovered from Liao tombs of Aluke'erqin Banner are likely to have been produced at the DSBET kiln site. Among these are a number of white- and green-glazed basins, excavated from Liao tombs at Xianfeng, Shuangsheng and Tianshankou townships, and white-glazed bowls from Liao tombs of Chaidamu township. The majority of these tombs have been dated to the Late Liao period, correspondingly proving the Liao status of DSBET.

2.1.9 The Gangguantun (GGT) Kiln

2.1.9.1 General Introduction

The extensive GGT kiln area is second in size only to the GWYC kiln. It is situated in Gangguantun village by the Taizi River, near the old site of Liaoyangfu (the Eastern Capital of Liao), about 30 kilometers east of today's Liaoyang city, Liaoning province (**Map 10, Pl. 64**).

A Japanese traveler, Adachi Yotaro, discovered the GGT kiln in 1905. Subsequently, it was repeatedly investigated by Japanese archaeologists. The wide extent of the area over which shards are distributed indicates the tract's large scale.

The GGT site comprises at least thirteen kilns, the majority of which are densely positioned on the south bank of the Taizi River behind the small village of Gangguantun. Judging from black-painted pieces resembling Cizhou-type wares, the GGT kiln presumably started its operation during the Late Liao. The supposition that the production site flourished during the Jin dynasty (1115-1234) is evidenced by two discoveries, an earthenware inkstone inscribed Shihchengxian and a number of Northern Song copper coins. As Yanzhou was renamed

Shichengxian during the Jin dynasty - the city was destroyed in Yuan times – the GGT kiln’s concurrence with it may be deduced.¹³¹ More kilns are located in the southwestern part of the village and east of the highway, at the base of Nanshan Hill. The black-glazed stoneware kilns, situated behind the village at the city gate of Yanzhou, near the north bank of the river, probably date back to the Yuan dynasty (1280-1368).

2.1.9.2 Kilns and Technology

Regarding the technology employed at GGT, similarities to the Cizhou kiln of China proper can be observed, despite the fact that its products are of comparatively rough quality. Its bowls and dishes are all only half-glazed on the outside. When stacked on top of each other, three to four clay-beads were positioned between the pieces as spacers (**Pl. 65, Pl. 66, Pl. 68**) and a round clay pad was put under the lowermost piece (**Pl. 69**). Up until the Jin and Yuan dynasties, an inside-glaze-sweeping method was applied and bead-spacers used in the stacking of the ceramics (**Pl. 67**). A special feature of the GGT kilns was that instead of saggars, fire-resistant bricks were used to support and protect the vessels in the kiln. Accordingly, not a single sagger fragment has ever been found in the area. The kilns are round and constructed with the fire-resistant bricks which are quite large and diversely patterned. Moreover, numerous conical instruments have been found in the proximity of the site and in the nearby river (**Pl. 79**), raising the question: Are these firing or fishing instruments? While no definite answer has yet been agreed upon, the habitat of the tools implies that they are likely to be products of the GGT kiln and were presumably used for fishing.

2.1.9.3 Varieties of Ceramics

The ceramic products of the GGT kiln site are mainly white-glazed, black-glazed, and brown-glazed stonewares. Further discoveries include a few pieces of white-glazed stonewares painted in black and resembling Cizhou wares of China proper. A sparse number of three-color lead-glazed earthenwares has also been found.

The white wares of the GGT kiln are generally of rough quality (**Pl. 80-Pl. 116**), and thus quite inferior to SJY wares and GWYC products. The vessels’ bodies are coarse and often display red and black specks. As was the custom with GWYC wares, a layer of white slip was also applied to the ceramic body before glazing at GGT. The hue of the glaze is a yellowish white, and in places where there is no slip it can be observed to be only semi-transparent. The majority of the ceramics produced were utensils intended for daily use, such as bowls (**Pl. 80-Pl. 89**), dishes (**Pl. 90-Pl. 92**), ewers (**Pl. 93 -Pl. 94**), jars (**Pl. 97-Pl. 101**), and vases (**Pl. 102, Pl. 103**). Various small toys, e.g. dogs, horses, camels, monster-headed ocarinas, and human figures, were also manufactured at the kiln (**Pl. 109-Pl. 114**). Notably, the majority of GGT products remained without surface decorations. Only very few examples of incised designs, imitating the Ding-style of China proper, were discovered. Among them was a white-glazed inkstone found at Gangguantun village (**Pl. 115**). Moreover, some shards were adorned with casual and

131 Li Wenxin 1958b, 97-107. “Shitoucheng” is the place name used during the Jin dynasty to replace the old name “Yanzhou 岩州”. The city was destroyed during the Yuan period.

sketchy designs, painted on the white slip in black or brown (**Pl. 105, Pl. 107**). Similar to designs on GWYC wares, GTT adornments are mostly straight lines or simple flower-bud or grass-blade motifs (**Pl. 107**). The workmanship is careless and clumsy. These pieces are presumably remains of the Late or post-Liao periods.

Black-glazed stonewares are of the same clay material as white-glazed stonewares, but produced into even coarser quality (**Pl. 117-Pl. 170**). The glaze is pure black and its application does not extend to the foot of the vessel. Many black-glazed bowls, jars, and bottles were made for daily use. A particular kind of coarse, red-bodied ware with lusterless gray-black glaze has also been discovered; however, it was produced in the Late Liao or post-Liao period. While there are some beautifully made black-glazed vessels, such as dishes, small jars, and big bowls, the variety of ceramic shapes is dominated by large, rough vessels designed for daily use, such as chicken-leg vases.

2.1.9.4 Property

Judging from its relatively rough and coarse products, the GGT kiln was a folk kiln. However, a full understanding of the site has not yet been achieved, requiring future studies to be conducted.

2.1.10 The Longquanwu (LQW) Kiln

2.1.10.1 General Introduction

The LQW is a kiln site representative of the Liao dynasty in ancient North China. It is located in Longquanwu village, 6 kilometers northeast of the Mentongou township in the western suburb of today's Beijing (the Southern Capital of Liao). The tract is bordered in by mountain chains on three sides, and by the Yongding River flowing north to south (**Map 12, Pl. 172**). The vicinity of the LQW kiln abounds with water resources, quality coal, and mudstone, all necessary means of production in a ceramic industry. Such favorable natural conditions provided the material foundation of setting up ceramic workshops.

The LQW kiln site is remarkably large-scale, stretching 230 meters east to west and 120 meters north to south, thus covering a total area of 27,600 square meters. The discovery of the tract dates back to 1975.¹³² In the early 1990s, an extensive archaeological excavation brought to light more than 8,000 objects, 13 kiln ruins, and 2 workshops within an unearthened area of over 1,000 square meters. (**Fig. 10, Fig. 11**)¹³³

These discoveries of the LQW kiln site are undoubtedly important, which provided quantities of materials to the study of the products, kiln structures and firing technique of this kiln site. They also offer evidences to understand the place of production of some white porcelains unearthened from Liao tombs and pagodas in Beijing area.

132 Lu Qi 1978, 26-32.

133 Liu Yiquan 1994; Huang Xiuchun et al. 1997; Zhao Guanglin 1986, 628-31.

The remains left on the LQW kiln site fall into seven layers, judging from the stratigraphical evidence recorded in the excavated area. Deposits of Liao culture can be divided into three phases, using cues from the form, glaze, body, and decoration of unearthed specimen. Based on the excavators' study, the LQW kiln is estimated to have started production around the reign of Emperor Taizong (927-947), and to have ceased after the fall of the Liao Empire.¹³⁴

2.1.10.2 Kilns and Technology

The LQW kilns are of a round, downdraft construction that is quite common in northern China. Overlooking the site, the individual kilns are built in an oblong or U-shape. Each kiln is composed of the fire chamber, the furnace bottom, and chimneys, generally measuring about 6 meters in length and 2.5 to 3.5 meters in width (**Fig. 12-Fig. 15**).

Kiln no. 13 has been best preserved (**Fig. 12**). It is U-shaped and about 5.44 meters long. Its irregularly trapezoid fire chamber, which is 0.95 meters deep, was repaired and reconstructed in ancient times. The furnace bottom is 3.12 meters long and 3.12 to 3.3 meters wide. The formerly fractured walls on the north and south side of the kiln have been conserved and reach to 0.18 meters at the highest point. The surface of the furnace bottom is covered with a 0.18 meter layer of grey-colored fire clay. Unfortunately, all four of the kiln's smock flues have been destroyed. The soil at the bottom of the two square chimneys was sintered into hardness and is covered with a grayish-brown tinge. To conserve the fire chamber and to preserve the heating temperature, two protective walls were built around the south and north sides of the kiln chamber, made from bluestones and saggars.

The LQW loading technique relied on the use of saggars to keep stacked vessels in place. Furthermore, clay spurs or round pads were spaced between the vessels as only very few pieces were loaded singly in a sagger (**Fig. 16**). Three-color-glazed wares were loaded upside down and supported by trigeminal spurs (**Fig. 17**). It is worth noting, that a loading method applying two mouth-facing saggars containing mouth-facing vessels, is seldom seen in other kiln sites of North China (**Fig. 19, Fig. 20**).

2.1.10.3 Varieties of Ceramics

The ceramics produced at the LQW kiln are predominantly white wares, but also comprise some black-glazed, brown-glazed, and teadust-green-glazed stonewares, as well as green-glazed and three-colored-glazed earthenwares.

The ceramic shapes of this kiln site are exclusively in the Han-style of China proper; the nomadic Khitan-style (such as the bag-shaped pilgrim flask, long-neck vase, phoenix-head vase, and oblong-lobed dish) does not appear at LQW. While the shapes occurring most frequently are bowls, dishes, jars, and vases, there are also fewer numbers of pillows, incense burners,

134 Phase I dates from 938 to 1031, Phase II from 1032 to 1056, Phase III from 1056 to 1125, Phase IV from 1125 to 1135; the phases accumulate to a total period of 180 years. Zhongguo guisuanyan xuehui 1982, 317.

boxes, chess pieces, and some animal-shaped toys like monkeys, sheep, dogs, oxen, lions, and camels (**Fig. 21**). These toys are small in size, varied in form, and lifelike in workmanship.

2.1.10.3.1 White Stoneware and Porcelain

The white wares of the LQW kiln can be broadly divided into two varieties according to their period of production.

White wares from the early phase of LQW production display traces of manufacturing by an inferior technology (**Pl. 173, Pl. 174**). The bodies of such pieces are coarse and not skillfully molded. The dim glaze is of a muddy opaque white, at times appearing greenish-gray or with a heavy yellowish tinge. Only one half of the outer wall of the vessel is coated in glaze, regardless of its function - bowl or dish - and the inner bottom commonly bears four spur scars. While there are some kundikas, jars, boxes, and vases, the white wares most frequently appear in the shapes of either bowls or dishes. The decorative design is uniform, and in most cases the surface remains plain.

In the Middle and Late Liao periods, white wares became increasingly finer (**Pl. 175-Pl. 177**), with white and hard bodies which imply a relatively high grade of porcelain. The glaze is a lustrous white with a slightly greenish tinge. The latter is caused, like that of some SJY products, by a certain degree of reduction during firing. In stark contrast to the finds of the Early Liao period, spur-marks inside round vessels of the Middle and Late Liao were decreased. The shapes most frequently occurring are round, daily used utensils like bowls, dishes, and cups. The bowls are comparatively deep containers resting on a ring foot and with a mouth curving slightly to the outside; in some cases they display a regular contour reminiscent of the segment of a sphere (**Pl. 176**). One particular type of bowl is decorated on the sides with shallow reliefs, suggesting long petals. Small dishes for the most part retain the overall shape of bowls, except that they are proportioned to be wider and shallower. Several other shapes, such as jars, ewers, saucers, and pure water bottles occur as well (**Fig. 21**).

As revealed by a portion of unearthed pieces, incised designs were the prevalent form of decoration, and counting among the most frequent motifs were lotus petals, plantain leaves, and scrolling designs (**Fig. 44, Fig. 98, Fig. 99**). The designs of some vessels creates an effect which is very similar to the one found on Ding wares of China proper.

Although the quality of LQW white wares differs according to the phase of production, the products remain to be of a higher standard than white wares produced at the GWYC and GGT kiln sites. The distinction of value is based on the glazing technique of LQW, according to which the glaze is applied directly onto the body, foregoing a prior coating of the ceramic with a layer of white slip.

Numerous of the white wares discovered in Beijing, which were formerly attributed to Ding and Xing wares, are identical to the shards found at the LQW kiln site. Hence, they should be identified as Liao rather than Song products.

2.1.10.3.2 Three-color-glazed Earthenware

The three-color-glazed ware began to be fired at the LQW kiln in the Middle and Late Liao periods, though only in small amounts. The fine and compact bodies were fired twice and coated with a smooth glossy glaze which gives the vessels a hue of yellow, green, or white with crackles. A thermo luminescence (TL) analysis conducted by the Shanghai Institute of Ceramics shows that the glaze of some three-color-glazed LQW shards contains 10-13% boric oxide, thus constituting evidence of the earliest use of the chemical in ceramics. Other examples could only be found in ceramics that were produced half a millennium later and are dated, on the one hand, to the reign of Kangxi (1662-1722) during the Qing dynasty of China, and to 1699 Japan on the other hand. The results of said TL analysis have been widely recognized by scholars worldwide; e.g. Nigel Wood¹³⁵ from the UK, and Robert A. Smith¹³⁶ from the USA published papers especially concerning the question of the discovery of boric oxide in LQW ceramics. Still, no modern technological analysis will ever suffice to answer the question, why Liao potters abandoned the 'modern' glaze technology they had discovered.

The recovery of three-color-glazed earthenwares and the molded instruments of square dishes from the LQW kiln site hints at the high level of production of three-color-glazed earthenwares in the Liao dynasty. Dishes, boxes, and pillows represent the most popular forms, the majority of which were made of fine clay and adorned with a luminous glaze (**Pl. 178**). The most frequent motifs of decoration are peonies, lotuses, butterflies, scroll flowers, etc. Apart from utensils for daily use, several big objects like building components were produced and later discovered at the LQW kiln site. More particularly the latter comprise zoomorphic ornaments for palace roofs, tile ends, and some sculptures of Buddha (**Pl. 179**). The designs on most of the big tile ends are plucked peony branches and chaplets. According to the forms and decorations, these three-color-glazed construction components were not used by the common people, but intended for palace buildings.¹³⁷ Several three-colored Buddhas, such as the ones collected in Liao temples (**Cat. 1339, Cat. 1338**), in the Kansas Museum (**Cat. 1340**), and in the Louvre, are all likely to have been produced at the LQW kiln site.

2.1.10.3.3 Black-glazed and Brown-glazed Wares

It is only a minority of LQW products which are glazed in brown, black, and tee-dust green. The body is white, similar to that of the white wares. Various shards of brown-glazed bowls are glazed in black on the mouth rim, while some black-glazed pieces are glazed in white on the interior.

2.1.10.4 Inscriptions on Ceramics

135 Wood 1999. Nigel Wood is an expert on ancient and modern glaze technology. He researched the subject at Oxford University, England, and teaches at London's Royal College of Art and the University of Westminster, as well as internationally.

136 Smith 1997. Dr. Smith is senior scientist at U.S. Borax Inc.

137 Beijingshi wenwu yanjiusuo 1990, 154-6.

Several chronological inscriptions have been discovered on three-color-glazed earthenwares, e.g. three Chinese characters - "Shouchang Wu" ('Shouchang' denoting the era of Emperor Daozong, 'Wu' being the pronunciation of the number five, resulting in a combined meaning of 'the fifth year of Shouchang', i.e. 1099) - incised on a three-colored tile fragment (**Pl. 180**). From this carving it is possible to deduce that three-color earthenware was already produced at the LQW kiln during the Liao Daozong period (1095-1101).

2.1.10.5 Property

The property of the LQW kiln site remains a controversial subject among scholars. While some believe it to be an official kiln, others argue in favor of a folk kiln. I am of the opinion that it is the latter school's position which is substantiated by the evidence unearthed from the site.

Due to the following reasons, I maintain that the LQW kiln site is a folk kiln:

- a) In Chinese history, many folk kilns are known to have produced ceramics for the government and the empire. Hence, it is possible that the LQW kiln, too, was a folk kiln which produced potteries for official purposes.
- b) According to the ancient literature *Songhuiyaojigao*, Liao had an official supervisor installed to control the production of the LQW kiln. While scholars arguing on behalf of an official kiln consider this fact their strongest argument, a close look at Chinese history provides grounds for reasonable doubt. Seeing as several Chinese kiln sites, such as the Yue and the Yaozhou kilns, were officially supervised but privately owned, it is well possible that a similar management operated at the LQW kiln.
- c) The products of the LQW kiln site include fine wares and coarse wares, which were fabricated for both official and commercial purposes. Different commodities were made to meet different needs, and accordingly, they can be found in both Liao tombs of common people and in the glaze tile construction components of the palace gardens of Liao's Southern Capital. Hence, it is safe to assume that both common people and the government consumed LQW produce.
- d) Based on ancient literature, special officials were placed at the LQW to control the tax collection from the workshops. This circumstance proves that the government insured the taxing of the owner of the commercial production site. Coincidentally, this is powerful evidence in support of the folk kiln school.

2.1.11 The Xiaoshuiyu (XSY) Kiln

The XSY kiln site is situated on the western bounds of Xiaoshuiyu village, in the northeast of Miyun county, Beijing area (**Map 13**). A stream flows by the eastern border of the tract.

It was discovered by Zhao Guanglin in 1979,¹³⁸ and is almost intact. The kiln site was seriously destroyed. Traces of three kilns remain on the ground. The firing instruments found

138 Zhao Guanglin 1984a, 408-15.

on-site contain saggars, support instruments, and spacers (**Pl. 181**). The firing technique employed at the XSY kiln is similar to that of the LQW kiln site, but the quality of its products is much coarser.

The main variety among the products fired at XSY is white ware; only few pieces of green ware and brown-glazed ware occur.

Ceramics manufactured at XSY are mainly vessels of simple shapes, such as bowls, jars, vases, basins, etc. The typical form of the chicken-leg vase was also fabricated at this location. Most of the vessels are undecorated, but some shards carved with lotus petals may also be found. The quality of the XSY produce, i.e. yellowish, grayish, or pinkish bodies is relatively rough. Even the bodies of white wares, despite a generally finer quality, bear impurities. Accordingly, XSY products are usually inferior to those of the neighboring LQW kiln, particularly in regard of hardness, refinement, and whiteness.

Production at the XSY kiln started in the Liao dynasty and continued into the Jin dynasty. Accordingly, most of the shards scattered on location can be dated to the Liao period. However, only very few of the white ware shards discovered at XSY were attributed to this age, as they are distinct from the more numerous remnants of Liao products by their far higher quality and especially fine make.

2.1.12 The Cjiawu (CJW) Kiln

The CJW kiln site is situated in Fangshan county, southwest of Beijing; the Dashi River flows by it from south to north (**Map 13**). The natural environment provides sources of coal and mineral clay. It was seriously destroyed. Unfortunately, the kiln site has been almost completely destroyed, leaving no traces of the actual kilns. Only shards and firing tools, i.e. saggars and support instruments, could be recovered from the grounds. A particularly extensive find was made in 1965, uncovering a multitude of shards and even several intact pieces like jars and chicken-leg vases. Further investigations were made in 1981, producing even more fragments and firing instruments (**Pl. 182**).¹³⁹

The CJW kiln was operated from the Early Liao period into the Jin and Yuan dynasties. The majority of the Liao products, which were of a rather rough quality, comprised white-glazed, black-glazed, and green-glazed stonewares. Most of these pieces are bluish-green half-glazed bowls; fewer vessels are finished in green, yellow, or brown. In the long history of the kiln, the most important phase is associated with the Jin and Yuan dynasties when techniques became more advanced and the ceramic products were of higher quality and better craftsmanship.

2.1.13 The Jiezhuang (JZY) Kiln

Located in Jiezhuang of Hunyuan county, Shanxi province, the JZY kiln is one of the early found kilns so far discovered in the area (**Map 14, Pl. 191**). The earliest kiln belonging to the site is situated in Guci village, which was built during the Tang dynasty. The finds taken from the

139 Zhao Guanglin 1984a, 408-15.

Guci kiln counted high amounts of bowls and jars in white or black glaze. The mat decoration of the vessels is similar to that of Henan. Bowls embellished with white glaze on the interior and black-glazed on the exterior are a trademark of this region.

The kiln site was discovered by Feng Xianming in 1977¹⁴⁰, and reinvestigated by Li Zhiyan in 1984¹⁴¹; a scientific excavation of the Tangkuaidi kiln of JZY was conducted by the Archaeology Institute of Shanxi province in 1997. The various products of the Tangkuaidi kiln contain Ding-style, white-glazed porcelain wares with impressed designs which were discovered at a Liao site in Qianwagou village of the Helinge'er township and in a tomb at Haoqianyingzi, Chayou Front Banner, Inner Mongolia. Furthermore, large quantities of black-glazed, big vases were recovered from a number of Liao tombs of the Late period, such as the WHW6 tomb in Datong city, Shanxi province, and the Liugong tomb in a southwestern suburb of the same town which is dated to 1119. These finds show that the Western Capital of Liao was the center of the distribution for the JZY kiln's products. While some white-glazed and black-glazed stonewares bearing carved decorations are also scattered on JZT kiln site area (**Pl. 191, Pl. 200**), no samples have been found in the tombs or at other Liao sites, forbidding the conclusion that these ceramics were fabricated during the Liao dynasty. Last to be mentioned is that the ceramic shapes of the discovered pieces mostly represent utensils intended for daily use, such as bowls, dishes, jars, pillows, and bottles (**Pl. 205-Pl. 211, Fig. 22**).

Regarding the firing and loading technique of JYZ, the five characteristic scars frequently left on the bottom of the bowls indicate that bead shaped support instruments were used as spacers between stacked vessels.

During the Jin and Yuan dynasties, the kiln produced black wares with carved designs which were quite common in the Yanbei region. Additionally, wares with cut or stamped decorations were made.

2.1.14 The Huairen (HRY) Kiln

HRY kiln comprises several kiln sites, namely the Emaokou (EMK), the Wujia (WJY), the Wanyao (WYY), and the Xiaoyu (XYY) kilns. The WJY kiln is the earliest among them (**Map 15**). The XYY kiln area is located 15 kilometers southwest of the center of Huairen county (**Map 15**), the EMK kiln lies 7.5 kilometers northwest of it (**Map 15**).

Multitudes of white-glazed, black-glazed, and brown-glazed stonewares (**Pl. 214-Pl. 247**) were discovered at the EMK kiln, which I had the fortune to visit myself in 2005. Some of these pieces are adorned with painted, incised, or carved decorations (**Pl. 240, Pl. 239, Pl. 227, Pl. 237**). Furthermore, several fragments of chicken-leg vases are scattered on the ground (**Pl. 236, Pl. 234**), the majority of which were produced during the Liao and Jin dynasties.

140 Feng Xianming 1984, 416-21.

141 Li Zhiyan 1985, 930-9.

The main products found at the XYY kiln are black wares (**Pl. 220**), e.g. vases with rope patterns and large-mouthed jars. The latter are usually decorated with simple carved designs and a glassy black glaze. The mouth of the jar is coarse and thick, and as such very distinct from its Datong counterparts. Traces of oil spot glaze were also found at the XYY kiln, but it seems not to have been commonly used.

The main products of the EMK kiln were black-glazed, brown-glazed, and teadust-green-glazed stonewares (**Pl. 222-Pl. 239**); yet, some white-glazed stonewares painted in black or bearing carved decorations were also discovered on the location, as well as several black-glazed stonewares with carved designs (**Pl. 240, Pl. 239, Pl. 227, Pl. 237**). The bodies of EMK stonewares are yellowish white and coarse. The shapes are dominated by utensils of daily use, i.e. bowls, dishes, some big jars, and chicken-leg vases. On the bottom of the ring-foot of some of the bowls, ink inscriptions like “Liu” and “Zhao” etc. can be found, denoting the first name of the owner or the producer of the bowl. The support instruments often left eight scars on the inside bottom of bowls and dishes.

2.1.15 The Datong (DTY) Kiln

The DTY kiln is located in a suburb of Datong, about 11.5 kilometers from the city’s center (**Map 15**).

The site was investigated by Ye Zhemin in 1977. The main products of the DTY kiln are black-glazed stonewares, some of them with carved designs. The decorations of incised and carved designs are more sophisticated than those found on wares of the HRY kiln; most of the DTY pieces were produced during the Liao and Jin dynasties. Jars and chicken-leg vases can also often be found on the tract.

2.1.16 The Longhua (LHY) Kiln

Japanese scholars came across the LHY site in Longhua county, Hebei province, in the early 1940s (**Map 7**). The main products of the kiln, which was operated during the Liao and Jin dynasties, were white-glazed, black-glazed, and brown-glazed stonewares, as well as white-glazed stonewares painted with black pigment. The vessels are roughly made and have loose bodies.

2.2 FINDS FROM TOMBS, PAGODAS, AND RESIDENT SITES

2.2.1 Dated Tombs and Pagodas

As most Liao kiln sites have not been scientifically excavated, the extensive amount of Liao ceramics found in Liao tombs and pagodas constitute highly important materials for a typological and chronological study of these tracts. Importantly, epitaphs and other inscriptions have been preserved in a number of tombs and pagodas, providing reliable information for the precise dating of these places. Even on ceramics pieces themselves, inscriptions of dating have been discovered. The shoulder of one chicken-leg vase, for example, bears the incision "Qian ... year" (i.e. 'Qiantong such-and-such year'; Qiantong denoting the era of Liao's last emperor Tianzuodi from 1101-1110).¹⁴² Such references recorded on Liao ceramics procure reliable evidence for the correct dating of the pieces, even if they stem from hitherto undated Liao tombs and sites, or are part of a museum collection. Hence, they form the basic material for this study (see Table 3).

Table 3 Dated Liao Tombs and Discoveries of Liao Ceramics

No.	Abb. name of tomb or pagoda	Owner	Place			Dating evidence	Date (AD)	Emperor	Unearthed ceramics
			Province	Banner/ city/ county/ district	Township/ village				
1	BS1 ¹⁴³	Unknown	Inner Mongolia	Aluke'erqin Banner	Baoshan	Ink inscription	923	Taizu	White-glazed dishes and jars; brown-glazed bowls.

¹⁴² Neimenggu zizhiq wenwu gongzuodui 1963.

¹⁴³ Qi Xiaoguang et al. 1998, 73-95.

No.	Abb. name of tomb or pagoda	Owner	Place			Dating evidence	Date (AD)	Emperor	Unearthed ceramics
			Province	Banner/city/county/district	Township/village				
2	YLYZ ¹⁴⁴	Yelü Yuzhi and Chonggun	Inner Mongolia	Aluke'erqin Banner	Hansumu	Epitaph	942	Taizong	White-glazed bag-shaped pilgrim flasks, long-neck vases, jars, flat-bottom bowls, bowls, and basins; brown-glazed bag-shaped pilgrim flasks, dish-mouth bottles, and jars; green-glazed vases.
3	ZDJ ¹⁴⁵	Zhao Dejun	Beijing			Epitaph	958	Muzong	White-glazed boxes, bowls; unglazed pottery basins and jars.
4	FMM ¹⁴⁶	Fuma Xiao Shilu and Zhigu	Inner Mongolia	Linxi county, Chifeng city	Dayingzi	Epitaph	959	Muzong	White-glazed bag-shaped pilgrim flasks, long-neck vases, ewers and jars; green-glazed pilgrim flasks; teadust-green-glazed jars.
5	YMT7 ¹⁴⁷	Unknown	Liaoning	Faku county		Inscription on lacquered ware	977	Jingzong	Brown-glazed bag-shaped pilgrim flasks, long-neck bottles and jars; teadust-green-glazed chicken-leg vases; white-glazed long-neck vases, ewers and bowls.

144 Neimenggu wenwu kaogu yanjiusuo 1996, 4-32.

145 Beijingshi wenwu gongzuodui 1962, 246-253.

146 Zheng Shaozong 1956, 1-26.

147 Liaoningsheng bowuguan et al. 1975, 26-36.

No.	Abb. name of tomb or pagoda	Owner	Place			Dating evidence	Date (AD)	Emperor	Unearthed ceramics
			Province	Banner/city/county/district	Township/village				
6	LYN ¹⁴⁸	Yelü Yanning	Liaoning	Chaoyang city		Epitaph	986	Shengzong	White-glazed saucers and bowls; unglazed grey pottery long-neck bottles.
7	HYM ¹⁴⁹	Han Yi	Beijing	Shijingshan district	Babaoshan	Epitaph	1011	Shengzong	White-glazed spittoons, jars, bowls, and flat-bottom bowls; teadust-green-glazed chicken-leg vases.
8	LYJ ¹⁵⁰	Liu Yujie	Liaoning	Chaoyang city		Epitaph	1000	Shengzong	White-glazed dishes; white-glazed shards painted with black pigment; pottery jars, vases, and bottles.
9	SJG1 ¹⁵¹	Unknown	Liaoning	Chaoyang city	Shangjiagou	Epitaph	1002	Shengzong	Green-glazed bag-shaped pilgrim flasks; white-glazed ewers, warming bowls, jars, bowls, and dishes.
10	WYM ¹⁵²	Wang Yue	Liaoning	Kazuo county, Chaoyang city		Epitaph	1005	Shengzong	White-glazed bowls.

148 Liaoningsheng bowuguan wenwu gongzuodui 1980, 18-22.

149 Huang Xiuchun et al. 1984, 361-81.

150 Wang Chengsheng 1987.

151 Deng Baoxue et al. 1983, 30-38.

152 Li Wenxin et al. 1962, 479-87.

No.	Abb. name of tomb or pagoda	Owner	Place			Dating evidence	Date (AD)	Emperor	Unearthed ceramics
			Province	Banner/city/county/district	Township/village				
11	Pagoda JGS ¹⁵³	Jing Guang Monastery	Beijing	Shunyi county		Dvaja	1014	Shengzong	White-glazed human-shaped porcelain ewer; white-glazed ewers, vases, jars, dishes, and boxes.
12	HXM ¹⁵⁴	Han Xiang	Hebei	Qian'an	Shanglu villiage	Epitaph	1017	Shengzong	Green-glazed bag-shaped pilgrim flasks; white-glazed ewers, sauces, bowls, and dishes.
13	CGGZ ¹⁵⁵	Princess of Chen and Xiao Shaoju	Inner Mongolia	Naiman Banner	Qinglong-shan	Epitaph	1018	Shengzong	Green-glazed long-neck vases, and jars; teadust-green-glazed chicken-leg vases; white-glazed jars, boxes, and bowls.
14	GY ¹⁵⁶	Geng Yanyi	Liaoning	Chaoyang city	Guyingzi	Epitaph	1020	Shengzong	Green-glazed bag-shaped pilgrim flasks; white-glazed jars, ewers, bowls, and dishes.
15	GZX ¹⁵⁷	Geng Zhixin	Liaoning	Chaoyang city	Guyingzi	Epitaph	1026	Shengzong	White-glazed brush-washer bowls, jars, ewers, bowls, dishes and saucers; green-glazed bag-shaped pilgrim flask; yellow-glazed ewers and warming bowls.

153 Su Tianjun 1964, 49-51.

154 Tang Yunming 1973, 276-8.

155 Sun Jianhua & Zhangyu 1987, 4-24; Neimenggu wenwu kaogu yanjiusuo et al. 1993.

156 Zhu Zifang & Xu Ji 1983, 168-195.

157 Zhu Zifang & Xu Ji 1983, 168-195.

No.	Abb. name of tomb or pagoda	Owner	Place			Dating evidence	Date (AD)	Emperor	Unearthed ceramics
			Province	Banner/city/county/district	Township/village				
16	XJM ¹⁵⁸	Xiao Jin	Liaoning	Fuxin city		Epitaph	1029	Shengzong	White-glazed shards.
17	JGFR ¹⁵⁹	Dame of Jin (Jin Guo Furen)	Liaoning	Fuxin city		Epitaph	1038	Xingzong	Yellow-glazed, green-glazed, and misty-blue-glazed shards.
18	Pagoda CYBTTG ¹⁶⁰	Celestial palace of north pagoda	Liaoning	Chaoyang city		Inscription on brick	1043	Xingzong	White-glazed porcelains.
19	Pagoda CYBTDG ¹⁶¹	Under-ground palace of north pagoda	Liaoning	Chaoyang city		Inscription on brick	1044	Xingzong	White-glazed square dishes, round dishes, bowls, jars, and kundikas; green-glazed ware.
20	Pagoda WGJGSLT ¹⁶²	Wugou Jinguang Sheli Ta	Liaoning	Shenyang city		Inscription on stone case	1044	Xingzong	White-glazed kundikas.

158 Li Yufeng & Yuan Haibo 1988..

159 Li Wenxin 1958a, 10-22.

160 Dong Gao & Zhang Hongbo 1992, 1-28.

161 Dong Gao & Zhang Hongbo 1992, 1-28.

162 Shenyangshi wenguanhui et al. 1986.

No.	Abb. name of tomb or pagoda	Owner	Place			Dating evidence	Date (AD)	Emperor	Unearthed ceramics
			Province	Banner/city/county/district	Township/village				
21	QHM1 ¹⁶³	Unknown	Liaoning	Yi county	Qinghemem	Epitaph	1044	Xingzong	White-glazed bag-shaped pilgrim flasks, long-neck vases, spittoons, and jars.
22	LRY ¹⁶⁴	Liu Riyong	Liaoning	Chaoyang city		Epitaph	1046	Xingzong	White-glazed sheep-shaped stoneware painted with black pigment.
23	Pagoda QZBT ¹⁶⁵	Baita	Inner Mongolia	Balin Right Banner	Qingzhou	Inscription on tablet	1049	Xingzong	White-glazed dishes.
24	Pagoda BZCT ¹⁶⁶		Beijing	Fangshan county	Beizheng-cun village	Inscription on stone case	1051	Xingzong	White-glazed dishes.
25	WZM ¹⁶⁷	Wang Ze	Beijing	Fengtai district		Epitaph	1053	Xingzong	White-glazed porcelain bowls, dishes, saucers, boxes, kundikas, jars, brush-washers, and lamps; black-glazed jars; misty-blue-glazed bowls.

163 Li Wenxin 1954, 163-202.

164 Wang Chengsheng 1987.

165 De Xin et al. 1994, 4-33.

166 Qi Xin & Liu Jingyi 1980, 147-58.

167 Beijingshi wenwu guanlichu 1972, 35-40.

No.	Abb. name of tomb or pagoda	Owner	Place			Dating evidence	Date (AD)	Emperor	Unearthed ceramics
			Province	Banner/city/county/district	Township/village				
26	QHM2 ¹⁶⁸	Xiao Shenwei	Liaoning	Yi county	Qinghemem	Epitaph	1057	Daozong	Green-glazed bag-shaped pilgrim flasks, phoenix-head vases, jars; white-glazed bowls, boxes, vases, ewers, and basins.
27	Pagoda DLS ¹⁶⁹	Dulesi Temple	Tianjin	Ji county			1058	Daozong	White-glazed and green-glazed wares.
28	ZKY ¹⁷⁰	Zhao Kuangyu	Liaoning	Chaoyang city		Epitaph	1060	Daozong	White-glazed ewers with carved designs, bowls, and dishes.
29	SFC ¹⁷¹	Unknown	Inner Mongolia	Balin Left Banner	Sifang-cheng	Dvaja	1066	Daozong	Green-glazed phoenix-head vases; yellow-glazed big dishes; three-color-glazed inkstone; white-glazed bag-shaped pilgrim flasks.
30	XTM (MWG3) ¹⁷²	Xiao Tang	Inner Mongolia	Ningcheng county, Chifeng city	Maiwang-gou	Epitaph	1070	Daozong	White-glazed wares; three-color-glazed earthenware; misty-blue-glazed porcelains.

168 Li Wenxin 1954, 163-202.

169 Tianjin lishi bowuguan kaogudui et al. 1989, 89-119.

170 Deng Baoxue et al.1983, 30-38.

171 Li Wenxin 1958, 97-107.

172 Ji Ping & Ta La 1997, 609-30.

No.	Abb. name of tomb or pagoda	Owner	Place			Dating evidence	Date (AD)	Emperor	Unearthed ceramics
			Province	Banner/ city/ county/ district	Township/ village				
31	XFJ ¹⁷³	Xiao Fujun	Inner Mongolia	Ningcheng county, Chifeng city	Yuezhangzi	Epitaph	1072	Daozong	White-glazed stoneware; green-glazed earthenware; yellow-glazed earthenware; brown-glazed stoneware; misty-blue-glazed porcelain wares.
32	XDW ¹⁷⁴	Xiao Dewen	Liaoning	Fuxin city		Epitaph	1075	Daozong	White-glazed jars painted with black; green-glazed bowls; misty-blue-glazed shards.
33	QDC ¹⁷⁵	Qin Dechang	Liaoning	Jianping county	Sanjiaxiang	Epitaph	1075	Daozong	White-glazed stoneware; green-glazed earthenware; yellow-glazed earthenware; green-glazed stoneware; misty-blue-glazed porcelains.
34	KL1 ¹⁷⁶	Unknown	Inner Mongolia	Kulun Banner	Wulibuge village	Copper coins	1080	Daozong	White-glazed, gourd-shaped ewer, jars, vases, bowls, and flat-bottom bowls.

173 Neimenggu wenwu kaogu yanjiusuo et al. 1994, 548-52.

174 Li Wenxin 1958, 97-107.

175 Li Bo 1995, 14-19.

176 Wang Jianqun & Chen Xiangwei 1989.

No.	Abb. name of tomb or pagoda	Owner	Place			Dating evidence	Date (AD)	Emperor	Unearthed ceramics
			Province	Banner/ city/ county/ district	Township/ village				
35	XBTB (MWG4) ¹⁷⁷	Xiao Beiteben	Inner Mongolia	Ningcheng county, Chifeng city	Maiwang-gou	Epitaph	1081	Daozong	White-glazed wares; yellow-glazed earthenware; misty-blue-glazed porcelains.
36	BTZM ¹⁷⁸	Unknown	Inner Mongolia	Aohan Banner	Baitazi	Dvaja	1081	Daozong	Yellow-glazed earthenware; misty-blue-glazed porcelains.
37	XXZ ¹⁷⁹	Xiao Xiaozhong	Liaoning	Jinxi county	Xigushan	Epitaph	1089	Daozong	Yellow-glazed bag-shaped pilgrim flasks; green-glazed phoenix-head vases; three-color-glazed square dishes and oblong-lobed dishes.
38	XPL ¹⁸⁰	Xiao Paolu	Liaoning	Faku county		Epitaph	1090	Daozong	White-glazed bowls, dishes, boxes, and ewers.
39	ZKM ¹⁸¹	Zheng Ke	Liaoning	Jianping county		Epitaph	1090	Daozong	White-glazed bowls; brown-glazed jars; three-color-glazed dishes; yellow-glazed spittoons.

177 Ji Ping & Ta La 1997, 609-30.

178 Shao Guotian 1978, 119-21.

179 Yan Yu 1960, 34-5.

180 Feng Yongqian 1983, 624-35.

181 Li Wenxin 1958, 97-107.

No.	Abb. name of tomb or pagoda	Owner	Place			Dating evidence	Date (AD)	Emperor	Unearthed ceramics
			Province	Banner/city/county/district	Township/village				
40	DHB ¹⁸²	Unknown	Liaoning	Lingyuan county	Dahebei township	Epitaph	1091	Daozong	
41	WHW6 ¹⁸³	Unknown	Shanxi	Datong city	Wohuwan	Title deed for land	1093	Daozong	Black-glazed jars.
42	ZKZ ¹⁸⁴	Zhang Kuangzheng	Hebei	Xuanhua	Xiabali	Epitaph	1093	Daozong	White-glazed stoneware; yellow-glazed earthenware; teadust-green-glazed stoneware; three-color-glazed earthenware.
43	ZWZ ¹⁸⁵	Zhang Wenzao	Hebei	Xuanhua	Xiabali	Epitaph	1093	Daozong	White-glazed stoneware; yellow-glazed earthenware; teadust-green-glazed stoneware; three-color-glazed earthenware.
44	DLZ ¹⁸⁶	Unknown	Liaoning	Liaoyang city	Dalinzi	Epitaph	1096	Daozong	White-glazed ware and black-glazed ware.

182 Liu Li 1994b, 104-9.

183 Bian Chengxiu 1959, 73.

184 Liu Haiwen et al. 1995. Hebeisheng wenwu guanlichu et al. 1975, 31-39.

185 Zheng Shaozong 1996, 14-46; Tao Zongyi et al. 1990, 1-19.

186 Yi Qing'an 1956, 79-80.

No.	Abb. name of tomb or pagoda	Owner	Place			Dating evidence	Date (AD)	Emperor	Unearthed ceramics
			Province	Banner/city/county/district	Township/village				
45	LHM ¹⁸⁷	Liu Hu	Inner Mongolia	Aohan Banner		Epitaph	1099	Daozong	White-glazed wares.
46	SWFM ¹⁸⁸	Shang Wei	Inner Mongolia	Ningcheng city	Zhouzhang-zi	Epitaph	1099	Daozong	White-glazed bowls, dishes, ewers, warming bowls and cups.
47	YLQ ¹⁸⁹	Yelü Qi	Inner Mongolia	Aluke'erqin Banner		Epitaph	1108	Tianzuo	Misty-blue-glazed bowls and dishes with impressed designs.
48	WHW3 ¹⁹⁰	Unkknown	Shanxi	Datong city	Wohuwan	Epitaph	1109	Tianzuo	White-glazed wares.
49	GSM ¹⁹¹	Guo shi	Shanxi	Datong city		Epitaph	1109	Tianzuo	White-glazed and green-glazed wares.
50	Pagoda CSS ¹⁹²	Chongshou Temple	Liaoning	Shenyang city		Inscription on stone case	1108	Tianzuo	Misty-blue-glazed porcelains.

187 Shao Guotian et al. 1999c, 1-38, 43.

188 Zheng Long 1961, 50-1.

189 Qi Xiaoguang 1997, 7-13.

190 Zhang Bingren 1963, 432-36.

191 Bian Chengxiu 1959, 73.

192 Li Wenxin 1958, 10-22.

No.	Abb. name of tomb or pagoda	Owner	Place			Dating evidence	Date (AD)	Emperor	Unearthed ceramics
			Province	Banner/city/county/district	Township/village				
51	HSX ¹⁹³	Han Shixun	Hebei	Xuanhua city	Xiabali	Epitaph	1111	Tianzuo	White-glazed and yellow-glazed wares.
52	ZTM ¹⁹⁴	Unknown	Beijing		Zhaitang	Dvaja	1111	Tianzuo	White-glazed jars; three-color-glazed burners and jars.
53	MZW ¹⁹⁵	Ma Zhiwen couples	Beijing	Daxing county		Epitaph	1113	Tianzuo	White-glazed bowls and dishes; misty-blue-glazed saucers.
54	DWD ¹⁹⁶	Ding Wendao	Beijing			Epitaph	1113	Tianzuo	White-glazed bowls and dishes; green-glazed bowls.
55	Pagoda JJS ¹⁹⁷	Foundation of pagoda in Jingjuesi temple	Hebei	Yi county		Ink inscription	1115	Tianzuo	White-glazed dishes; misty-blue-glazed bowls, dishes, vases, saucers, and burners.

193 Liu Haiwen & Yancheng 1992, 1-11.

194 Beijingshi wenwu shiye guanliju et al. 1980, 23-7.

195 Zhang Xiande 1980, 30-7.

196 Beijingshi wenwu gongzuodui 1963, 145-46.

197 Shi Yongshi 1986, 76-80.

No.	Abb. name of tomb or pagoda	Owner	Place			Dating evidence	Date (AD)	Emperor	Unearthed ceramics
			Province	Banner/ city/ county/ district	Township/ village				
56	ZSQ ¹⁹⁸	Zhang Shiqing	Hebei	Xuanhua city	Xiabali	Epitaph	1116	Tianzuo	Yellow-glazed bowls, ewers, spittoons, saucers and single hand flat-bottom bowls; three-color-glazed dishes; black-glazed chicken-leg vases.
57	ZGY ¹⁹⁹	Zhang Gongyou	Hebei	Xuanhua city	Xiabali	Epitaph	1117	Tianzuo	White-glazed ewers, dishes and bowls; brown-glazed and teadust-green-glazed chicken-leg vases.
58	LCS ²⁰⁰	Liu Chengsui	Shanxi	Datong city		Epitaph	1119	Tianzuo	White-glazed bowls and flat-bottom bowls; black-glazed vases.
59	ZSB ²⁰¹	Zhang Shibei couples	Hebei	Xuanhua city	Xiabali	Epitaph	1115-1144	Tianzuo	White-glazed bowls and dishes; yellow-glazed, single handle, flat-bottom bowls, gourd-shaped ewers, bowls, saucers, and spittoons; yellow- and green-glazed basins. Brown-glazed vases.

198 Hebeisheng wenwu guanlichu et al. 1975, 31-39.

199 Tao Zongyi et al. 1990, 1-19.

200 Bian Chengxiu 1959, 73.

201 Tao Zongyi et al. 1990, 1-19.

2.2.2 Undated Tombs

At the current stage of archaeological studies, most Liao tombs lack epitaphs or other chronological inscriptions to aid an estimation of their dating. Therefore, any attempt to attribute them to a certain era must be made on the basis of several factors, such as the type and the form of the tombs, burial objects, and relations between various burial objects in the same tomb. By comparing these aspects to characteristics of the dated Liao tombs listed in Table 1, it is possible to determine an estimate date of otherwise undated tombs.

Table 4 Undated Liao Tombs and Liao Ceramics Discovered Therein in Comparison with Dated Tombs

No.	Abb. name of tomb	Place			Unearthed ceramics	Comparison with dated tombs	Parallel, dated tombs/rough date
		Province	Banner/city/county/district	Township/village			
1	SZG1 ²⁰²	Inner Mongolia	Aohan Banner	Shazigou	White-glazed wares 9; green-glazed wares 3.	A black-burnished dish-mouthed bottle is similar to the ones discovered in the YLYZ tomb. A green-glazed bag-shaped flat-bottom pilgrim flask, as well as an iron jar, a bronze mirror, and some harness attachments are similar to counterparts from the FMM tomb.	YLYZ (942) FMM (959)
2	DQTL3 ²⁰³	Inner Mongolia	Keyou Middle Banner	Daiqintala	White-glazed wares 11; green-glazed wares 18; brown-glazed wares 2.	Some jars and flat-bottom bowls are similar to counterparts from the YLYZ tomb. Some bowls are similar to the ones found in the SZG1 tomb. As proved before, SZG1 can be dated close to the YLYZ and FMM tombs.	YLYZ (942) FMM (959)

202 Shao Guotian 1987, 889-904.

203 Meng Jianren & Piao Chunyue 1997, 651-67.

No.	Abb. name of tomb	Place			Unearthed ceramics	Comparison with dated tombs	Parallel, dated tombs/rough date
		Province	Banner/city/county/district	Township/village			
3	HLB1 ²⁰⁴	Liaoning	Fuxin city	Hailiban	White-glazed wares 14; green-glazed wares 4; brown-glazed ware 1; misty-blue-glazed ware 1.	Some step cups, long-neck bottles, dishes, and jars are similar to counterparts discovered in the SZG1 tomb. Some jars are similar to ones discovered in the YLYZ and FMM tombs. Some bag-shaped pilgrim flasks are similar to counterparts discovered in the DQTL3 tomb. SZG1 and DQTL3 are dated close to the YLYZ and FMM tombs.	YLYZ (942) FMM (959)
4	HLDT2 ²⁰⁵	Liaoning	Kangping county	Houliudong-tun	White-glazed wares 3; misty-blue-glazed wares 8.	Some bag-shaped pilgrim flasks are similar to counterparts discovered in the HLB1 tomb. The HLB1 tomb is dated close to the YLYZ and FMM tombs.	YLYZ (942) FMM (959)
5	ZKC1 ²⁰⁶	Liaoning	Jinzhou city	Zhangkang villiage	White-glazed wares 9.	A dish-mouthed, lugged bottle is similar to counterparts discovered in the DQTL3 tomb. Some pottery jars are similar to the ones discovered in the ZDJ tomb. DQTL3 is dated close to the YLYZ and FMM tombs.	YLVZ (942) FMM (959) ZDJ (958)

204 Li Yufeng 1991, 106-19, 23.

205 Zhang Shaoqing 1988, 819-24.

206 Liu Qian 1984, 990-1002.

No.	Abb. name of tomb	Place			Unearthed ceramics	Comparison with dated tombs	Parallel, dated tombs/rough date
		Province	Banner/city/county/district	Township/village			
6	QJZ ²⁰⁷	Liaoning	Fuxin city	Qijiazi	White-glazed ware 1; brown-glazed ware 1; misty-blue-glazed ware 1.	Some bag-shaped pilgrim flasks are similar to counterparts discovered in the HLB1 tomb. HLB1 tomb is dated close to the YLYZ and FMM tombs.	YLYZ (942) FMM (959)
7	NZLYZ1 ²⁰⁸	Liaoning	Fuxin city	Nanzao-liyin gzi	White-glazed wares 2; brown-glazed ware 1; misty-blue-glazed ware 1.	Some jars are similar to counterparts discovered in the YLYZ tomb. Some grey pottery, long-neck bottles are similar to the ones discovered in the HLB1 tomb. HLB1 tomb is dated close to the dated YLYZ and FMM tombs.	YLYZ (942) FMM (959)
8	DHG1 ²⁰⁹	Inner Mongolia	Aohan Banner	Dahenggou	Unglazed pottery wares.	Some dish-mouthed bottles are similar to counterparts discovered in the NZLYZ1 tomb. NZLYZ1 tomb is dated close to the dated YLYZ and FMM tombs.	YLYZ (942) FMM (959)
9	HSN ²¹⁰	Inner Mongolia	Keyou Rear Banner	Husinao	Unglazed pottery wares.	Some dish-mouthed bottles are similar to the ones discovered in the NZLYZ1 tomb. The NZLYZ1 tomb is dated close to the dated YLYZ and FMM tombs.	YLYZ (942) FMM (959)

207 Zhao Zhensheng & Bai Jie 1995, 1008 -12.

208 Liaoningsheng wenwu kaogu yanjiusuo et al. 1992, 54-63.

209 Shao Guotian 1987, 889-904.

210 Zhang Baizhong 1983, 18-22.

No.	Abb. name of tomb	Place			Unearthed ceramics	Comparison with dated tombs	Parallel, dated tombs/rough date
		Province	Banner/city/county/district	Township/village			
10	ZKC4 ²¹¹	Liaoning	Jinzhou city	Zhangkang villiage	Unglazed pottery wares.	A lugged pilgrim flask is similar to the ones discovered in the HSN tomb. The HSN tomb is dated close to the dated YLYZ and FMM tombs.	YLYZ (942) FMM (959)
11	MTYZ2 ²¹²	Inner Mongolia	Zhelimu Union	Mutouyinzi village, Nailingao township	White-glazed ware 1; green-glazed ware 1.	Some dish-mouthed bottles are similar to the ones discovered in the NZLYZ1 tomb. Some harness ornaments and buckle ornaments are similar to the ones discovered in the FMM tomb. The NZLYZ1 tomb is dated close to the dated YLYZ and FMM tombs.	YLYZ (942) FMM (959)
12	ZLK2 ¹³	Liaoning	Jianping city	Zhuluke	White-glazed wares 7.	Some long-neck vases and ewers are similar to counterparts discovered in the FMM tomb. Some white-glazed porcelain bowls are similar to the ones discovered in the YLYZ and FMM tombs.	YLYZ (942) FMM (959)
13	BYD ²¹⁴	Liaoning	Fuxin city	Baiyüdu	White-glazed wares 7; white-glazed earthenware with green pigment.	Some bag-shaped pilgrim flasks are similar to counterparts discovered in the HLB1 tomb. A ewer is similar to the ones discovered in the ZLK tomb. The HLB1 and ZLY tombs are both dated close to the dated tombs of YLYZ and FMM.	YLYZ (942) FMM (959)

211 Liu Qian 1984, 990-1002.

212 Zheng Long 1981, 231-43.

213 Feng Yongqian 1960, 15-24.

No.	Abb. name of tomb	Place			Unearthed ceramics	Comparison with dated tombs	Parallel, dated tombs/rough date
		Province	Banner/city/county/district	Township/village			
14	EBD2 ²¹⁵	Inner Mongolia	Keshiketeng Banner	Erbadi	Dark-green-glazed ware 1; black pottery wares 2.	Some dish-mouthed bottles are similar to counterparts discovered in the YLYZ, HLB1, and SZG tombs. The HLB1 and SZG tombs are dated close to YLYZ and FMM tombs.	YLYZ (942) FMM (959)
15	EBD1 ²¹⁶	Inner Mongolia	Keshiketeng Banner	Erbadi	Green and yellow-glazed long-neck vase 1; unglazed black pottery dish-mouth bottle 1.		907-969
16	GCM ²¹⁷	Inner Mongolia	Balin Left Banner	Goucun village	White-glazed wares.		907-969
17	ZJY1 ²¹⁸	Liaoning	Jianping city	Zhangjiayao	Green-glazed bag-shaped pilgrim flask.		907-969

214 Yuan Haibo 1985, 958-59.

215 Xiang Chunsong 1984a, 80-90.

216 He Yong & Pang Ruixiang 1990.

217 Xiang Chunsong 1999.

218 Pei Yaojun 1996, 57-62.

No.	Abb. name of tomb	Place			Unearthed ceramics	Comparison with dated tombs	Parallel, dated tombs/rough date
		Province	Banner/city/county/district	Township/village			
18	BLC ²¹⁹	Liaoning	Chaoyang city	Boluochi	Green-glazed, dish-mouthed, lugged vase		907-969
19	CYZ ²²⁰	Liaoning	Lingyuan county	Caiyuanzi village	White-glazed bag-shaped pilgrim flask with black painted.		907-969
20	GMC ²²¹	Inner Mongolia	Wengniute Banner	Goumencun village	Green-glazed ware.		907-969
21	HLC1 ²²²	Hebei	Shangyi	Huluncun village	White-glazed ware 1; green-glazed wares 2; yellow-glazed ware 1; brown-glazed ware 1.		907-969

219 Feng Yongqian 1981c, 65-71.

220 Liu Li 1994b, 104-9.

221 Feng Yongqian 1981, 65-71.

222 He Yong & Pang Ruixiang 1990, 21-6.

No.	Abb. name of tomb	Place			Unearthed ceramics	Comparison with dated tombs	Parallel, dated tombs/rough date
		Province	Banner/city/county/district	Township/village			
22	MTYZ1 ²²³	Inner Mongolia	Zhelimu Union	Mutouyingzi village, Nailingao township	White-glazed ware 1.		907-969
23	DQTL1 ²²⁴	Inner Mongolia	Keyou Middle Banner	Daiqintala	White-glazed bowls 2; green-glazed saucer 1.		907-969
24	HLDT1 ²²⁵	Liaoning	Kangping county	Houliudongtun	White-glazed wares.		907-969
25	KPYZ1 ²²⁶	Liaoning	Beipiao	Koupuyinzi	White-glazed wares 2.		907-969
26	QYC ²²⁷	Inner Mongolia	Linxi	Qiyi village	White-glazed dish-mouth bottle 1.		907-969

223 Zheng Long 1981, 231-43.

224 Meng Jianren & Piao Chunyue 1997, 651-67.

225 Zhang Shaoqing 1986, 922-25.

226 Liaoning Chaoyang diqu wenwuzu 1978, 129-34.

227 Wang Gang 1997.

No.	Abb. name of tomb	Place			Unearthed ceramics	Comparison with dated tombs	Parallel, dated tombs/rough date
		Province	Banner/city/county/district	Township/village			
27	YBS ²²⁸	Liaoning	Jianping	Yebaishou	Green-glazed wares.		907-969
28	DST3 ²²⁹	Inner Mongolia	Zhunge'er	Dashata	Black-glazed dish-mouth lugged vase 1; unglazed pottery 5.		907-969
29	ABEGE ²³⁰	Inner Mongolia	Balin Right Banner	Aobaoenge'er	White-glazed bowl 1; Unglazed grey pottery chicken-leg vases 2.		907-969
30	HSXM ²³¹	Heilongjiang		Heshanxiang	Unglazed pottery jars 2.		907-969

228 Liaoningsheng bowuguan 1961.

229 Zheng Long 1981, 95-101.

230 Neimenggu wenwu kaogu yanjiusuo 1994a, 537-41.

231 Fu Weiguang & Jin Zhu 1989, 32-5.

No.	Abb. name of tomb	Place			Unearthed ceramics	Comparison with dated tombs	Parallel, dated tombs/rough date
		Province	Banner/city/county/district	Township/village			
31	LBB ²³²	Liaoning	Faku county	Libeibao	White-glazed ware 2; green-glazed earthenware 1; green-glazed stoneware 1; unglazed pottery ware 1.		907-969
32	SJYM ²³³	Heilongjiang		Shajiayao	Unglazed pottery wares.		907-969
33	XFZC ²³⁴	Heilongjiang		Xinfeng-zhuang	Unglazed pottery bottle 1.		907-969
34	AYC ²³⁵	Heilongjiang	Zhaodong city	Anye village	Unglazed grey pottery dish-mouthed bottle 1; unglazed black pottery jar 1.		907-969

232 Lin Maoyu & Xian Junyan 2001, 36-43.

233 Qiao Liang & Yang Jing 2001, 44-50.

234 Qiao Liang & Yang Jing 2001, 44-50.

235 Zhang Jie & Zhu Tao 2004, 38-39.

No.	Abb. name of tomb	Place			Unearthed ceramics	Comparison with dated tombs	Parallel, dated tombs/rough date
		Province	Banner/city/county/district	Township/village			
35	ZDB ²³⁶	Liaoning	Chaoyang	Zhaoduba	White-glazed ware 1; yellow-glazed wares 2; unglazed pottery ware 1.		907-969
36	CGWS ²³⁷	Inner Mongolia	Balin Right Banner	Chaganwusu			907-969
37	SLG3 ²³⁸	Inner Mongolia	Keyou Middle Banner	Shuanglong-gang	Unglazed grey pottery bottle 1.		907-969
38	SLG1 ²³⁹	Inner Mongolia	Keyou Middle Banner	Shuanglong-gang	Unglazed pottery jar 1.		907-969
39	SLG2 ²⁴⁰	Inner Mongolia	Keyou Middle Banner	Shuanglong-gang	Unglazed pottery bottle 1.		907-969

236 Chaoyangshi bowuguan 2004, 64-66.

237 Miao Runhua 1995, 20-4.

238 Neimenggu wenwu kaogu yanjiusuo 1997, 60-7.

239 Neimenggu wenwu kaogu yanjiusuo 1997, 60-7.

240 Neimenggu wenwu kaogu yanjiusuo 1997, 60-7.

No.	Abb. name of tomb	Place			Unearthed ceramics	Comparison with dated tombs	Parallel, dated tombs/rough date
		Province	Banner/city/county/district	Township/village			
40	WJF ²⁴¹	Inner Mongolia	Linxi	Wujianfang	White-glazed wares 2; unglazed black pottery bottle 1.		907-969
41	BYTL ²⁴²	Inner Mongolia	Kazuo Rear Banner	Baiyintala	Unglazed grey pottery long-neck bottle 1.		907-969
42	GDG ²⁴³	Inner Mongolia	Wengniute Banner	Guangdegong township	Green-glazed wares 3.	Some bag-shaped pilgrim flasks are similar to counterparts discovered in the YMT7 tomb.	YMT7(977)
43	BZLG ²⁴⁴	Inner Mongolia	Keyou Middle Banner	Bazhalaga	White-glazed ware 1; green-glazed wares 2.	Some bag-shaped pilgrim flasks are similar to counterparts discovered in the GDG tomb. The GDG tomb is dated close to the YMT7 tomb.	YMT7(977)
44	DEQG ²⁴⁵	Inner Mongolia	Aluke'erqin Banner	Dao'erqige	Green-glazed wares 2.	Some bag-shaped pilgrim flasks are similar to counterparts discovered in the BZLG tomb. The BZLG tomb is dated close to the YMT7 tomb.	YMT7(977)

241 Wang Gang & Lü Qing 2001, 124-26.

242 Ben Heling 2002.

243 Xiang Chunsong 1989, 41-44.

244 Su Ritai 1982, 64-68.

245 Cong Yanshuang 1992, 149-51.

No.	Abb. name of tomb	Place			Unearthed ceramics	Comparison with dated tombs	Parallel, dated tombs/rough date
		Province	Banner/city/county/district	Township/village			
45	DJWP ²⁴⁶	Inner Mongolia	Ningcheng	Dujiawopu	Green-glazed wares; yellow-glazed wares.	A green-glazed long-neck bottle is similar to the ones discovered in the YMT7 tomb. The shape of a dark-yellow-glazed, lugged pilgrim flask is similar to that of a green-glazed one discovered in the GDG tomb. The GDG tomb is dated close to YMT7 tomb.	YMT7(977)
46	AXZ ²⁴⁷	Beijing	Shunyi county	Anxinzhuang	White-glazed wares 6; green-glazed ware 1; yellow-glazed wares 2; misty blur glazed wares 4.	A bag-shaped pilgrim flask and a long-neck vase are similar to counterparts discovered in the YMT7 tomb.	YMT7(977)
47	XTTG3 ²⁴⁸	Inner Mongolia	Ningcheng	Xiaotang-tugou	White-glazed wares.	A long-necked ewer is similar to one discovered in the YMT7 tomb.	YMT7(977)

246 Liaoningsheng bowuguan 1961.

247 Beijingshi wenwu yanjiusuo 1992, 17-23.

248 Qi Xiaoguang 1991, 68-71.

No.	Abb. name of tomb	Place			Unearthed ceramics	Comparison with dated tombs	Parallel, dated tombs/rough date
		Province	Banner/city/county/district	Township/village			
48	BL4 ²⁴⁹	Liaoning	Kazuo county	Beiling	White-glazed wares 4; green-glazed pilgrim flasks 2; brown and white-glazed ware 1.	A ewer bearing a carved design of lotus petals is similar to the ones discovered in the SJG1 tomb.	SJG1 (1002)
49	CGB11 ²⁵⁰	Inner Mogolia	Balin Left Banner	Chaganba	White-glazed wares 5.	Some bag-shaped pilgrim flasks are similar to counterparts discovered in the BL4 tomb. The BL4 tomb is dated close to the SJG1 tomb.	SJG1 (1002)
50	DSL1 ²⁵¹	Liaoning	Zhangwu county	Dashalitu	White-glazed wares 5; yellow-glazed wares 2.	A basin is similar to the one discovered in the CGB11 tomb. The CBGB11 tomb is dated close to the SJG1 tomb.	SJG1 (1002)

249 Wu Jiachang 1986, 32-51.

250 Dong Wenyi 1984, 91-93.

251 Wan Xin 1999, 15-23.

No.	Abb. name of tomb	Place			Unearthed ceramics	Comparison with dated tombs	Parallel, dated tombs/rough date
		Province	Banner/city/county/district	Township/village			
51	QHM4 ²⁵²	Liaoning	Yi county	Qinghemmen	White-glazed wares 4; tea-dust green-glazed ware 1; misty-blue-glazed wares 8; green-glazed wares 3; black-glazed wares 2.	A white-glazed, bag-shaped pilgrim flask is similar to the ones discovered in the SJG1 tomb. A long-neck bottle is similar to the ones discovered in the CGGZ tomb.	SJG1 (1002) CGGZ (1018)
52	SQ1 ²⁵³	Liaoning	Beipiao county	Shuiquan	White-glazed wares 6; green-glazed earthenware 7; misty-blue-glazed wares 6; green-glazed stoneware 1.	A bag-shaped pilgrim flask is similar to the ones discovered in the HXM and GYY tombs.	HXM (1017) GYY (1020)

252 Li Wenxin 1954, 163-202.

253 Xu Yulin 1977, 44-51.

No.	Abb. name of tomb	Place			Unearthed ceramics	Comparison with dated tombs	Parallel, dated tombs/rough date
		Province	Banner/city/county/district	Township/village			
53	KL3 ²⁵⁴	Inner Mongolia	Kulun Banner		White-glazed wares 3; green-glazed earthenware 1; green-glazed stoneware 1.	A jar is similar to the ones discovered in the pagoda JGS.	Pagoda JGS (1014)
54	QCH ²⁵⁵	Liaoning	Chaoyang city	Qianchuang-hu	White-glazed wares 5; green-glazed earthenware 13; misty-blue-glazed wares 2; green-glazed stoneware 1.	Some bag-shaped pilgrim flasks are similar to counterparts discovered in the HXM and GYY tombs. Phoenix-head vases are similar to ones discovered in the SQ1 tomb.	HXM (1017) GYY (1020)
55	BL1 ²⁵⁶	Liaoning	Kazuo county	Beiling	White-glazed wares 8; green-glazed wares 2; tea-dust green-glazed ware 1.	Some bag-shaped pilgrim flasks are similar to counterparts discovered in the HXM and GYY tombs. A white-glazed porcelain ewer with a design of carved lotus petals is similar to the ones discovered in the SQ1 tomb.	HXM (1017) GYY (1020)

254 Wang Jianqun & Chen Xiangwei 1989.

255 Jin Fengyi 1980, 17-29.

256 Wu Jiachang 1986, 32-51.

No.	Abb. name of tomb	Place			Unearthed ceramics	Comparison with dated tombs	Parallel, dated tombs/rough date
		Province	Banner/city/county/district	Township/village			
56	ELC ²⁵⁷	Inner Mongolia	Tongliao county	Erlinchang	White-glazed ware 1; green-glazed wares 3; three-color-glazed earthenware 1; green-glazed stoneware 3.	Some bag-shaped pilgrim flasks are similar to counterparts discovered in the HXM and GYY tombs.	HXM (1017) GYY (1020)
57	ZKC2 ²⁵⁸	Liaoning	Jinzhou city	Zhangkang village	White-glazed ware 1; green-glazed earthenwares 5; misty-blue-glazed wares 2; green-glazed stoneware 1.	Some bag-shaped pilgrim flasks are similar to counterparts discovered in the HXM and GYY tombs.	HXM (1017) GYY (1020)
58	PJG1 ²⁵⁹	Inner Mongolia	Aohan Banner	Pijianggou	White-glazed ware 1; green-glazed ware 1; black-glazed ware 1; marbled green-glazed ware 1.	Some bag-shaped pilgrim flasks are similar to counterparts discovered in the HXM and GYY tombs.	HXM (1017) GYY (1020)

257 Zhang Baizhong 1985, 56-62.

258 Liu Qian 1984, 990-1002.

259 Qiu Guobin 1998, 46-52, 63.

No.	Abb. name of tomb	Place			Unearthed ceramics	Comparison with dated tombs	Parallel, dated tombs/rough date
		Province	Banner/city/county/district	Township/village			
59	SLC ²⁶⁰	Hebei	Qian'an	Shanglu village	White-glazed wares; Green-glazed wares.	982-1031	
60	WDGM ²⁶¹	Hebei	Fengning county	Wudaogou-men	White-glazed ware 1; green-glazed ware 2; tea-dust green-glazed ware 1; unglazed pottery wares 3.	982-1031	
61	YMT5 ²⁶²	Liaoning	Faku county	Yemaotai	White-glazed wares.	982-1031	
62	YWG ²⁶³	Hebei	Luanping county	Yinwogou	White-glazed wares 5; green-glazed wares 4.	982-1031	

260 Meng Zhaoyong & Chen Ping 1990, 88-91.

261 Zhang Hanying 1996, 18-25.

262 Feng Yongqian 1994, 163-90.

263 Ma Qingpeng & Zhao Zhihou 1997, 47-49.

No.	Abb. name of tomb	Place			Unearthed ceramics	Comparison with dated tombs	Parallel, dated tombs/rough date
		Province	Banner/city/county/district	Township/village			
63	YFC ²⁶⁴	Hebei	Ji county	Yingfangcun	Green-glazed bag-shaped pilgrim flasks 2.		982-1031
64	ZKC3 ²⁶⁵	Liaoning	Jinzhou city	Zhangkang village	Green-glazed bag-shaped pilgrim flask.		982-1031
65	BXT ²⁶⁶	Inner Mongolia	Keyou Front Banner	Baixintun	White-glazed wares 3.		982-1031
66	SSG4 ²⁶⁷	Inner Mongolia	Kalaqin Banner	Shangshao-guo	Green-glazed wares.		982-1031
67	XJG ²⁶⁸	Hebei	Pingquan county	Xiaojigou	White-glazed long-neck ewer; green-glazed bag-shaped pilgrim flask.		982-1031

264 Zhao Wengang 1992, 36-41.

265 Liu Qian 1984, 990-1002.

266 Pan Xingyong 1965, 374-6.

267 Xiang Chunsong 1991, 33-39.

268 Zhang Xiufu et al. 1982, 50-53.

No.	Abb. name of tomb	Place			Unearthed ceramics	Comparison with dated tombs	Parallel, dated tombs/rough date
		Province	Banner/city/county/district	Township/village			
68	XDZ ²⁶⁹	Heilongjiang		Xidianzi	Unglazed pottery jar 1.		982-1031
69	JZZ ²⁷⁰	Liaoning	Beipiao county	Jizhangzi	White-glazed wares 4.		982-1031
70	DYZ ²⁷¹	Inner Mongolia	Chifeng	Dayingzi	White-glazed wares 4.	Some bag-shaped pilgrim flasks are similar to counterparts discovered in the QHM1 tomb.	QHM1 (1044)
71	SLG ²⁷²	Inner Mongolia	Keyou Middle Banner	Shuanglong-gang	White-glazed bowl 1; green-glazed bag-shaped pilgrim flasks 2.		1031-1055
72	SLG ²⁷³	Inner Mongolia	Keyou Middle Banner	Shuanglong-gang	Unglazed pottery wares 3.		1031-1055

269 Qiao Liang & Yang Jing 2001, 44-50.

270 Han Baoxing 1995, 149-56.

271 Zheng Shaozong 1956, 1-26.

272 Neimenggu wenwu kaogu yanjiusuo 1997, 60-7.

273 Neimenggu wenwu kaogu yanjiusuo 1997, 60-7.

No.	Abb. name of tomb	Place			Unearthed ceramics	Comparison with dated tombs	Parallel, dated tombs/rough date
		Province	Banner/city/county/district	Township/village			
73	DXG1 ²⁷⁴	Liaoning	Jianping county	Daxigou	White-glazed wares 15; green-glazed ware 1.		1031-1055
74	DSJ ²⁷⁵	Liaoning	Kazuo county	Dasanjia	White-glazed bag-shaped pilgrim flask with green painted.		1031-1055
75	HPC ²⁷⁶	Inner Mongolia	Linxi	Hepingcun village	Green-glazed ware.		1031-1055
76	YMT2 ²⁷⁷	Liaoning	Faku county	Yemaotai	Green-glazed earthenwares 4; green-glazed stoneware 11; tea-dust green-glazed stoneware 2; unglazed pottery basin 1.		1031-1055

274 Xin Yan & Hua Yubing 1991, 40-47.

275 Chaoyangshi bowuguan 1996.

276 Feng Yongqian 1981, 65-71.

No.	Abb. name of tomb	Place			Unearthed ceramics	Comparison with dated tombs	Parallel, dated tombs/rough date
		Province	Banner/city/county/district	Township/village			
77	XHD ²⁷⁸	Inner Mongolia	Linxi	Xiaohada	White-glazed earthenware 2; white-glazed stoneware 2; green-glazed earthenwares 9; green-glazed stoneware 1.		1031-1055
78	HTH1 ²⁷⁹	Inner Mongolia	Zhalute Banner	Haotehua	White-glazed earthenware 1; green-glazed earthenwares 3; green-glazed stoneware 1.		1031-1055
79	DPC ²⁸⁰	Liaoning	Zhangwu	Dongping village	White-glazed wares 3.		1031-1055
80	XNRM ²⁸¹	Inner Mongolia	Kazuo Middle Banner	Xiaonuri	White-glazed porcelain wares 5.		1031-1055

277 Xu Zhiguo & Wei Chunguang 2000, 48-51.

278 Wang Gang 1998, 40-9.

279 Zhongguo shekeyuan neimenggu gongzuodui et al. 2003, 3-14.

280 Liu Junyu & Sun Gang 1999, 31-4.

No.	Abb. name of tomb	Place			Unearthed ceramics	Comparison with dated tombs	Parallel, dated tombs/rough date
		Province	Banner/city/county/district	Township/village			
81	TZM2 ²⁸²	Liaoning	Fuxin	Tizimiao	White-glazed wares 7; Green-glazed jar 1.		1031-1055
82	TZM3 ²⁸³	Liaoning	Fuxin	Tizimiao	Green-glazed bowl 1.		1031-1055
83	BTYZ ²⁸⁴	Liaoning	Xinmin	Batuyingzi	White-glazed wares 15; green-glazed wares 4; yellow-glazed wares 3; brown-glazed wares 3; misty-blue-glazed ware 1; three-colored glazed wares 2.	Some bag-shaped pilgrim flasks and long-neck vases are similar to counterparts discovered in the QHM2 tomb.	QHM2 (1057)

281 Wu Yaqin & Wang Ruiqing 2000.

282 Liao Zhenjin & Wang Yi 2004, 31-37.

283 Liao Zhenjin & Wang Yi 2004, 31-37.

284 Feng Yongqian 1960, 15-24.

No.	Abb. name of tomb	Place			Unearthed ceramics	Comparison with dated tombs	Parallel, dated tombs/rough date
		Province	Banner/city/county/district	Township/village			
84	LTL ²⁸⁵	Jilin	Shuangliao	Luotuoling	Yellow-glazed wares.	Some bag-shaped pilgrim flasks are similar to ones discovered in the QHM2 tomb.	QHM2 (1057)
85	XDM ²⁸⁶	Inner Mongolia	Chifeng city	Xindi	Green-glazed wares; yellow-glazed wares.	Spittoons are similar to the ones discovered in the HPYZ1 tomb. Bag-shaped pilgrim flasks and long-neck vases are similar to the ones discovered in the QHM2 tomb. The HPYZ1 tomb is dated close to the XBTB(MWG4) tomb.	QHM2 (1057) XBTB (MWG4) (1081)
86	MJ1 ²⁸⁷	Liaoning	Zhangwu county	Majia	White-glazed wares 6; misty-blue-glazed ware 1.	Some bowls are similar to the ones discovered in the XFJ tomb.	XFJ (1072)
87	BL3 ²⁸⁸	Liaoning	Kazuo	Beiling	White-glazed wares 2; yellow-glazed wares 5; three-color-glazed wares 8.	Yellow-glazed, bag-shaped pilgrim flasks and three-color-glazed, oblong lobed dishes are similar to counterparts discovered in the XXZ tomb. A ewer is similar to the ones discovered in the KL1 tomb.	KL1 (1080) XXZ (1089)

285 Duan Yiping 1983a, 43-6.

286 Xiang Chunsong 1990, 38-41

287 Wan Xin 1999, 15-23.

288 Wu Jiachang 1986, 32-51.

No.	Abb. name of tomb	Place			Unearthed ceramics	Comparison with dated tombs	Parallel, dated tombs/rough date
		Province	Banner/city/county/district	Township/village			
88	HPYZ1 ²⁸⁹	Inner Mongolia	Chifeng city	Hepingyingzi	Green-glazed ware 1; yellow-glazed wares 2; tea-dust green-glazed wares 2; three-color-glazed ware 1.	Some bag-shaped pilgrim flasks are similar to the ones discovered in the XBTB(MWG4) tomb.	XBTB (MWG4) (1081)
89	FZZ ²⁹⁰	Inner Mongolia	Aohan Banner	Fanzhangzi	White-glazed wares 3; brown-glazed wares 2; three-color-glazed ware 1.	A yellow-glazed phoenix-head vase is similar to the ones discovered in the XXZ tomb. Three-color-glazed lobbed dishes are similar to the ones discovered in the XXZ and BL3 tombs.	XXZ (1089)
90	XLZZ1 ²⁹¹	Inner Mongolia	Ningcheng county	Xiaoliuzhangzi	White-glazed wares 6; yellow-glazed wares 5; three-color-glazed wares 5.	Three-color-glazed, oblong lobed dishes are similar to the ones discovered in the BL3 tomb. A saucer from XLZZ1 is similar to ones discovered in the JFYZ tomb. Three-color square dishes from XLZZ1 are similar to the ones discovered in the XXZ tomb.	XXZ (1089)

289 Xiang Chunsong 1991, 33-39.

290 Ta La & Yiyou 1984, 75-9.

291 Li Yiyou 1961, 44-9.

No.	Abb. name of tomb	Place			Unearthed ceramics	Comparison with dated tombs	Parallel, dated tombs/rough date
		Province	Banner/city/county/district	Township/village			
91	XLZZ2 ²⁹²	Inner Mongolia	Ningcheng county	Xiaoliuzhangzi	Green-glazed wares 2; yellow-glazed ware 1; three-color-glazed wares 2.		
92	XLZZ3 ²⁹³	Inner Mongolia	Ningcheng county	Xiaoliuzhangzi	Green-glazed wares 2; yellow-glazed ware 1' three-color-glazed wares 2.		
93	XLZZ4 ²⁹⁴	Inner Mongolia	Ningcheng county	Xiaoliuzhangzi	Green-glazed wares 2; yellow-glazed ware 1; three-color-glazed wares2.		

292 Li Yiyou 1961, 44-9.

293 Li Yiyou 1961, 44-9.

294 Li Yiyou 1961, 44-9.

No.	Abb. name of tomb	Place			Unearthed ceramics	Comparison with dated tombs	Parallel, dated tombs/rough date
		Province	Banner/city/county/district	Township/village			
94	JFYZ ²⁹⁵	Liaoning	Jianping and Xinmin	Jiefangyingzi	Green-glazed ware 1; yellow-glazed wares 11; three-color-glazed wares 8.	Some bag-shaped pilgrim flasks and long-neck vases are similar to counterparts discovered in the QHM2 tomb. A flat-bottom bowl is similar to the ones discovered in the XLZZ1 tomb. The XLZZ1 tomb is dated close to the KL1 and XXZ tombs.	QHM2 (1057) KL1 (1080) XXZ (1089)
95	CDM ²⁹⁶	Inner Mongolia	Aluke'erqin Banner	Chaidamu	White-glazed ware 1; green-glazed ware 1.	The construction form of the tomb is similar to that of the XLZZ3 and XLZZ4 tombs. The burial custom is similar that of the XLZZ and JFYZ tombs. The XLZZ tombs are dated close to the KL1 and XXZ tombs.	KL1 (1080) XXZ (1089)
96	WLHD ²⁹⁷	Inner Mongolia	Aluke'erqin Banner	Wulanhada	White-glazed wares 3; green-glazed wares 2.	Some bag-shaped pilgrim flasks are similar to the ones discovered in the CDM tomb. CDM tomb is dated close to KL1 and XXZ tombs.	KL1 (1080) XXZ (1089)
97	HQYZ6 ²⁹⁸	Inner Mongolia	Chayou Front Banner	Haoqianyingzi	White-glazed wares 12.	Some dishes are similar to the ones discovered in the XLZZ1 and WLHD tombs. The WLHD tomb is dated close to the KL1 and XXZ tombs.	KL1 (1080) XXZ (1089)

295 Feng Yongqian 1960, 15-24.

296 Tian Li & Qi Xiaoguang 1981, 77-79.

297 Wang Jianguo & Ma Junshan 1986, 74-76.

298 Wumeng wenwu gongzuozhan 1985, 7-44.

No.	Abb. name of tomb	Place			Unearthed ceramics	Comparison with dated tombs	Parallel, dated tombs/rough date
		Province	Banner/city/county/district	Township/village			
98	HQYZ9 ²⁹⁹	Inner Mongolia	Chayou Front Banner	Haoqianying-zi	White-glazed wares 3; yellow-glazed ware 1.	Some dishes are similar to the ones discovered in the PJG3 and WLHD tombs. The PJG3 tomb is dated close to the KL1 and XXZ tombs.	KL1 (1080) XXZ (1089)
99	PJG2 ³⁰⁰	Inner Mongolia	Aohan Banner	Pijianggou	White-glazed wares 4; brown-glazed ware 1.	A gourd-shaped ewer is similar to the ones discovered in the BL3 tomb. The BL3 tomb is dated close to the KL1 and XXZ tombs.	KL1 (1080) XXZ (1089)
100	PJG3 ³⁰¹	Inner Mongolia	Aohan Banner	Pijianggou	White-glazed wares 4; brown-glazed ware 1.	Some bag-shaped pilgrim flasks are similar to the ones discovered in the BL3 tomb. Oblong lobed dishes are similar to the ones discovered in the XLZZ and BL3 tombs. Spittoons are similar to the ones discovered in the XLZZ4 tomb. The XLZZ4 and BL3 tombs are dated close to the KL1 and XXZ tombs.	KL1 (1080) XXZ (1089)
101	XPJG ³⁰²	Hebei	Fengning county	Xiaopijiang-gou	White-glazed ware1; yellow-glazed wares 2; three-colored glazed wares 2.	Three-colored square dishes are similar to the ones discovered in the XLZZ1 tomb. Phoenix-head vases are similar to the ones discovered in the XLZZ3 tomb. The XLZZ1 and XLZZ3 tombs are dated close to the KL1 and XXZ tombs.	KL1 (1080) XXZ (1089)

299 Wumeng wenwu gongzuozhan 1985, 7-44.

300 Qiu Guobin 1998, 46-52, 63.

301 Qiu Guobin 1998.

No.	Abb. name of tomb	Place			Unearthed ceramics	Comparison with dated tombs	Parallel, dated tombs/rough date
		Province	Banner/city/county/district	Township/village			
102	GS1 ³⁰³	Liaoning	Jianchang county	Guishan	White-glazed wares 6; yellow-glazed ware 1; tea-dust green-glazed ware 1; misty-blue-glazed wares 6.	A chicken-leg vase is similar to those chicken-leg vases bearing "Qian...year" (i.e. "Qiantong such-and-such year") inscriptions on their shoulders. Qiantong is the era of Emperor Tianzuo, 1101-1110. There also is a copper coin named "Shensong Yuanbao" 圣宋元宝, which was made in 1101.	Qiantong period (1101-1110)
103	JSF ³⁰⁴	Beijing	Xicheng district	Jinshifang road	Yellow-glazed wares 2.	A single-handled flat-bottom bowl is similar to the ones discovered in the ZSQ, ZWZ, and ZSB tombs.	ZWZ (1093) ZSQ (1116) ZSB (1115-1144)
104	BTZ ³⁰⁵	Inner Mongolia	Aohan Banner	Baitazi	Yellow-glazed bowl and dish.		1055-1125
105	HSM306	Inner Mongolia	Aluke'erqin Banner	Hansumusu-mu	White-glazed wares.		1055-1125

302 Zhang Hanying & Bai Guang 1993, 957-58.

303 Jin Fengyi & Xu Ji 1985, 48-55.

304 Beijingshi wenwu guanlichu 1972, 35-40.

305 Shao Guotian 1978, 119-21.

306 Liu Bing et al. 1998, 26-34, 38.

No.	Abb. name of tomb	Place			Unearthed ceramics	Comparison with dated tombs	Parallel, dated tombs/rough date
		Province	Banner/city/county/district	Township/village			
106	SHZC ³⁰⁷	Heilongjiang	Qiqihaer	Sanhezhuanchang, Meiersi	White-glazed wares.		1055-1125
107	MTCZ ³⁰⁸	Liaoning	Chaoyang	Mutouchengzi	White-glazed wares 2; green-glazed ware 1; tea-dust green-glazed ware 1.		1055-1125
108	QJG1 ³⁰⁹	Inner Mongolia	Chifeng city	Qujiagou	Three-color-glazed earthenware.		1055-1125
109	Hoard SGC ³¹⁰	Hebei	Chengde city	Sangoucun village	White-glazed wares.		1055-1125
110	SJZ ³¹¹	Liaoning	Lingyuan county	Sanjiazi township	Three-color-glazed ware.		1055-1125

307 Xin Jian & Cui Fulai 1991, 30-31.

308 Zhang keju 1995, 31-34.

309 Xiang Chunsong 1991, 33-39.

310 Tian Shuhua 1986, 83-6.

311 Liu Li 1994b, 104-9.

No.	Abb. name of tomb	Place			Unearthed ceramics	Comparison with dated tombs	Parallel, dated tombs/rough date
		Province	Banner/city/county/district	Township/village			
111	SGYZ ³¹²	Liaoning	Jianping city	Shaoguoyinzi	Three-color-glazed ware.		1055-1125
112	TJYZ ³¹³	Inner Mongolia	Ningcheng	Tiejiangyinzi	White-glazed wares; yellow-glazed ware.		1055-1125
113	YS3 ³¹⁴	Inner Mongolia	Aohan Banner	Yangshan village	White-glazed wares 8; yellow-glazed ware 1; three-color-glazed wares 2; misty-blue-glazed wares 5.		1055-1125
114	THCZ ³¹⁵	?	Qianguo	Tahucheng-zhi	White-glazed wares.		1055-1125

312 Chaoyangshi bowuguan 1996.

313 Zhao Guodong et al. 1997, 68-72.

314 Shao Guotian et al. 1999, 1-38, 43.

315 He Ming 1982a, 44-49.

No.	Abb. name of tomb	Place			Unearthed ceramics	Comparison with dated tombs	Parallel, dated tombs/rough date
		Province	Banner/city/county/district	Township/village			
115	TJYZM ³¹⁶	Liaoning	Beipiao	Taijiyingzi	Yellow-glazed ware.		1055-1125
116	WJS1 ³¹⁷	Inner Mongolia	Aluke'erqin Banner	Wanjinshan	White-glazed wares; white-glazed basin with green painted.		1055-1125
117	WJS2 ³¹⁸	Inner Mongolia	Aluke'erqin Banner	Wanjinshan	Yellow-glazed wares.		1055-1125
118	WJZ ³¹⁹	Liaoning	Fuxin city	Wujiazi	Green-glazed ware; yellow-glazed wares.		1055-1125
119	XLC5 ³²⁰	Liaoning	Chaoyang city	Xilao village	White-glazed box with green painted.		1055-1125

316 Chaoyangshi bowuguan 1996.

317 Liu Bing et al. 1998, 26-34, 38.

318 Liu Bing et al. 1998, 26-34, 38.

319 Zhao Zhensheng & Bai Jie 1995, 1008-12.

320 Wang Chengsheng 1987.

No.	Abb. name of tomb	Place			Unearthed ceramics	Comparison with dated tombs	Parallel, dated tombs/rough date
		Province	Banner/city/county/district	Township/village			
120	XSC4 ³²¹	Inner Mongolia	Tuquan county	Xishancun village	Green-glazed wares 3.		1055-1125
121	XSG ³²²	Liaoning	Kazuo county	Xishangen	Three-color-glazed ware.		1055-1125
122	XLZ ³²³ Z5	Inner Mongolia	Ningcheng	Xiaoliuzhang-zi	Yellow-glazed ware.		1055-1125
123	XTTG4 ³²⁴	Inner Mongolia	Ningcheng	Xiaotangtu-gou	Yellow-glazed long-neck bottle.		1055-1125
124	XLC ³²⁵	Inner Mongolia	Aluke'erqin Banner	Xinlincun village	Green-glazed wares; white-glazed basin with green painted.		1055-1125

321 Meng Jianren & Qian Yucheng 1994, 542-7.

322 Chaoyangshi bowuguan 1996.

323 Li Yiyou 1961, 44-9.

324 Qi Xiaoguang 1991c, 68-71.

325 Feng Yongqian 1981c, 65-71.

No.	Abb. name of tomb	Place			Unearthed ceramics	Comparison with dated tombs	Parallel, dated tombs/rough date
		Province	Banner/city/county/district	Township/village			
125	XLG ³²⁶	Liaoning	Kazuo	Xinglonggou	White-glazed wares.		1055-1125
126	YLW ³²⁷	Liaoning	Lingyuan county	Yanlanwa	Three-color-glazed inkstone.		1055-1125
127	YMT2 ³²⁸	Liaoning	Faku county	Yemaotai	White-glazed wares 7; three-color-glazed basin 1.		1055-1125
128	YMT3 ³²⁹	Liaoning	Faku county	Yemaotai	White-glazed wares;tea-dust green-glazed ware.		1055-1125
129	YMT8 ³³⁰	Liaoning	Faku county	Yemaotai	White-glazed wares 8.		1055-1125

326 Fu Zongde 1988, 381-83.

327 Liu Li 1994b, 104-9.

328 Feng Yongqian 1994a, 163-90.

329 Feng Yongqian 1994a, 163-90.

330 He Xianwu & Zhang Xingde 1996, 41-47.

No.	Abb. name of tomb	Place			Unearthed ceramics	Comparison with dated tombs	Parallel, dated tombs/rough date
		Province	Banner/city/county/district	Township/village			
130	YDM ³³¹	Beijing	Fengtai district	Yongding-men	White-glazed wares.		1055-1125
131	CZ1 ³³²	Beijing	Changping county	Chenzhuang village	White-glazed wares 4; green-glazed ware 1.		1055-1125
132	DGB ³³³	Liaoning	Fuxin city	Daguben	White-glazed wares.		1055-1125
133	KL6 ³³⁴	Inner Mongolia	Kulun Banner	Qianwulibu-g e	White-glazed wares 16.		1055-1125
134	CKTDS4 ³³⁵	Inner Mongolia	Aluke'erqin Banner	Chaoketu-d ngshan, Hansumus -mu	White-glazed bowls 2; green-glazed phoenix-head vase 1; white-glazed basin with green pigment painted 1.		1055-1125

331 Shoudu bowuguan 1991.

332 Changpingxian wenguansuo 1993, 68-77.

333 Liu Bing et al. 1998, 26-34, 38.

334 Zhelimumeng bowuguan et al. 1982, 35-46, 28.

No.	Abb. name of tomb	Place			Unearthed ceramics	Comparison with dated tombs	Parallel, dated tombs/rough date
		Province	Banner/city/county/district	Township/village			
135	DYHT ³³⁶	Beijing		Dayu Alley	Black-glazed wares.		1055-1125
136	DZZ ³³⁷	Liaoning	Kazuo county	Dazhangzi village	Green-glazed wares.		1055-1125
137	DGBM ³³⁸	Hebei	Langfang city, Yongqing county	Dongguanbei	White-glazed porcelain gourd-shaped ewer.		1055-1125
138	FTM ³³⁹	Beijing	Fengtai district		White-glazed wares		1055-1125
139	GJT ³⁴⁰	Inner Mongolia	Tuquan	Guojiatun	Green-glazed wares.		1055-1125

335 Liu Bing et al. 1998, 26-34, 38.

336 Beijingshi wenwu guanlichu 1972, 35-40.

337 Fu Zongde 1988, 861-2.

338 Zhang Zhaoxiang & Wu Yuru 1997, 61-3.

339 Shoudu bowuguan 1991.

340 Li Yiyu 1955, 122-23.

No.	Abb. name of tomb	Place			Unearthed ceramics	Comparison with dated tombs	Parallel, dated tombs/rough date
		Province	Banner/city/county/district	Township/village			
140	HXMD ³⁴¹	Inner Mongolia	Aluke'erqin Banner	Haoxiumao-du	White-glazed ware.		1055-1125
141	HRBH ³⁴²	Inner Mongolia	Aohan Banner	Hurenbaohe village	Black-glazed ware.		1055-1125
142	JSM ³⁴³	Inner Mongolia	Xinghe	Jianshan	White-glazed ware 1.		1055-1125
143	NLZ ³⁴⁴	Liaoning	Liaoyang	Nanlinzi	White-glazed wares 2.		1055-1125
144	PLCZ ³⁴⁵	Jilin	Lishu	Pianlianchengzi	White-glazed ewer 1.		1055-1125

341 Feng Yongqian 1981, 65-71.

342 Shao Guotian 1997.

343 Cheng Tangdong & Li Xingsheng 1988.

344 Liaoyangshi wenwu guanlisuo 1977, 90-1.

345 Jilinsheng wenwu guanli weiyuanhui 1958, 26-31.

No.	Abb. name of tomb	Place			Unearthed ceramics	Comparison with dated tombs	Parallel, dated tombs/rough date
		Province	Banner/city/county/district	Township/village			
145	QHZ ³⁴⁶	Hebei	Shangdu	Qianhaizi village	Green-glazed basin 1; tea-dust green-glazed chicken-leg vases 2.		1055-1125
146	KL5 ³⁴⁷	Inner Mongolia	Kulun Banner	Qianwulibu-g e	White-glazed box 1.		1055-1125
147	WDEARS ³⁴⁸	Inner Mongolia	Aluke'erqin Banner	Wenduoerao-ruishan	White-glazed wares;		1055-1125
148	WJT ³⁴⁹	Liaoning	Lingyuan county	Wenjiatun	White-glazed ware; yellow-glazed wares.		1055-1125
149	Pagoda YXT ³⁵⁰	Beijing	Miyun county	Yexianta	White-glazed wares.		1055-1125

346 Fu Zhanjun 1990, 49-51.

347 Zhelimumeng bowuguan et al. 1982, 35-46, 28.

348 Liu Bing & Zhao Guochen 1993, 57-67.

349 Han Baoxing 1994, 23-7.

350 Wang Youquan 1994, 58-64.

No.	Abb. name of tomb	Place			Unearthed ceramics	Comparison with dated tombs	Parallel, dated tombs/rough date
		Province	Banner/city/county/district	Township/village			
150	XSC3 ³⁵¹	Inner Mongolia	Tuquan	Xishancun village	Unglazed pottery bottle 1.		1055-1125
151	XSC10 ³⁵²	Inner Mongolia	Tuquan	Xishancun village	Unglazed pottery vase 2.		1055-1125
152	XSC7 ³⁵³	Inner Mongolia	Tuquan	Xishancun village	White-glazed wares 3.		1055-1125
153	XSC9 ³⁵⁴	Inner Mongolia	Tuquan	Xishancun village	Green-glazed ware.		1055-1125
154	HMZ ³⁵⁵	Inner Mongolia	Chifeng	Hongmiaozi	White-glazed bowl 1; yellow-glazed vase 1; unglazed grey pottery wares 3.		1055-1125

351 Meng Jianren & Qian Yucheng 1994, 542-47.

352 Meng Jianren & Qian Yucheng 1994, 542-47.

353 Meng Jianren & Qian Yucheng 1994, 542-47.

354 Meng Jianren & Qian Yucheng 1994, 542-47.

355 Xiang Chunsong 1991, 33-39.

No.	Abb. name of tomb	Place			Unearthed ceramics	Comparison with dated tombs	Parallel, dated tombs/rough date
		Province	Banner/city/county/district	Township/village			
155	GDH1 ³⁵⁶	Inner Mongolia	Chifeng	Guduhe	White-glazed ware 1; three-color-glazed wares 4; unglazed grey pottery ware 1.		1055-1125
156	FLE ³⁵⁷	Heilongjiang		Fulaer	Unglazed pottery bottle.		1055-1125
157	ECM ³⁵⁸	Heilongjiang		Ercun	Unglazed pottery bottle.		1055-1125
158	GMZ ³⁵⁹	Liaoning	Chaoyang	Goumenzi	White-glazed wares 3; unglazed pottery wares 3.		1055-1125
159	CDMM ³⁶⁰	Liaoning	Zhangwu county	Chaidama			1055-1125

356 Xiang Chunsong 1991, 33-39.

357 Qiao Liang & Yang Jing 2001, 44-50.

358 Qiao Liang & Yang Jing 2001, 44-50.

359 Li Dajun 1997, 30-6.

360 Wang Laizhu 1996, 66-8.

No.	Abb. name of tomb	Place			Unearthed ceramics	Comparison with dated tombs	Parallel, dated tombs/rough date
		Province	Banner/city/county/district	Township/village			
160	FJTGX ³⁶¹	Inner Mongolia	Aluke'erqin Banner	Fanjiatun west	White-glazed wares 2; green-glazed wares 3; white-glazed basin with green painted 1.		1055-1125
161	FJTD ³⁶²	Inner Mongolia	Aluke'erqin Banner	Fanjiatun east	White-glazed wares 2.		1055-1125
162	LMG ³⁶³	Inner Mongolia	Aohan Banner	Lamagou	White-glazed bowls 2.		1055-1125
163	ZGZ ³⁶⁴	Hebei	Langfang city	Zhaigez-huang	Unglazed pottery wares 24.		1055-1125

361 Aluke'erqin qi wenguansuo et al. 1996, 78-81.

362 Aluke'erqin qi wenguansuo et al. 1996, 78-81.

363 Shao Guotian et al. 1999a, 90-97.

364 Langfang shi wenwu guanlisuo 1996, 9-12, 58.

No.	Abb. name of tomb	Place			Unearthed ceramics	Comparison with dated tombs	Parallel, dated tombs/rough date
		Province	Banner/city/county/district	Township/village			
164	XYFC ³⁶⁵	Hebei	Langfang city	Xiyongfeng-cun	White-glazed wares 8; green-glazed stone ware 1; unglazed pottery wares 11; misty-blue-glazed wares 2.		1055-1125
165	CGM ³⁶⁶	Hebei	Longhua county	Changgou-men			1055-1125
166	GSZ1 ³⁶⁷	Liaoning	Jianping	Gushanzi	White-glazed wares 3; misty-blue-glazed wares 2.		1055-1125
167	GSZ2 ³⁶⁸	Liaoning	Jianping	Gushanzi	White-glazed wares 2; misty-blue-glazed wares 1; unglazed pottery wares 2.		1055-1125

365 Langfang shi wenwu guanlisuo 1996, 9-12, 58.

366 Tao Min 2003, 50-51.

367 Yang Dongxin 2001, 87-88.

368 Yang Dongxin 2001, 87-88.

No.	Abb. name of tomb	Place			Unearthed ceramics	Comparison with dated tombs	Parallel, dated tombs/rough date
		Province	Banner/city/county/district	Township/village			
168	QYD1 ³⁶⁹	Beijing	Daxing county	Qingyundian	White-glazed bowl 1; unglazed pottery wares 12.		1055-1125
169	QYD2 ³⁷⁰	Beijing	Daxing county	Qingyundian	White-glazed bowls 2; green-glazed bowl 1; unglazed pottery wares 17.		1055-1125
170	PSY1 ³⁷¹	Liaoning	Jianping county	Paoshouying	White-glazed ware 1; yellow-glazed wares 4; three-color-glazed wares 3.		1055-1125
171	XLZ ³⁷²	Inner Mongolia	Chifeng city	Xinglongzhuang	White-glazed long-neck vase 1; green-glazed long-neck vase 1.		1055-1125

369 Beijingshi wenwu yanjiusuo 2004, 18-25.

370 Beijingshi wenwu yanjiusuo 2004, 18-25.

371 Xin Yan & Hua Yubing 1991, 40-47.

372 Xiang Chunsong 1991, 33-39.

No.	Abb. name of tomb	Place			Unearthed ceramics	Comparison with dated tombs	Parallel, dated tombs/rough date
		Province	Banner/city/county/district	Township/village			
172	SJF ³⁷³	Inner Mongolia	Chifeng city	Shijianfang	White-glazed bowl 1; green-glazed dishes 2.		1055-1125
173	WJD ³⁷⁴	Inner Mongolia	Chifeng city	Wangjiadian	Three-color-glazed mandarin duck-shaped ewer 1.		1055-1125
174	SBH ³⁷⁵	Inner Mongolia	Chifeng city	Sanbahuo	White-glazed ware 1; green-glazed ware 1; yellow-glazed ware 1; three-color-glazed ware 1.		1055-1125
175	SYZ1 ³⁷⁶	Inner Mongolia	Chifeng city	Shiyinzi	Yellow-glazed wares 8.		1055-1125

373 Xiang Chunsong 1991, 33-39.

374 Xiang Chunsong 1991, 33-39.

375 Xiang Chunsong 1991, 33-39.

376 Xiang Chunsong 1991, 33-39.

No.	Abb. name of tomb	Place			Unearthed ceramics	Comparison with dated tombs	Parallel, dated tombs/rough date
		Province	Banner/city/county/district	Township/village			
176	SYZ2 ³⁷⁷	Inner Mongolia	Chifeng city	Shiyinzi	Green-glazed bag-shaped pilgrim flask 1.		1055-1125
177	DLMA ³⁷⁸	Inner Mongolia	Chifeng	Dalaming'an	White-glazed ware 1; green-glazed wares 4; three-color-glazed wares 2.		1055-1125
178	GSH2 ³⁷⁹	Inner Mongolia	Chifeng	Guduhe	White-glazed porcelain dishes 3; Green-glazed wares 3.		1055-1125
179	YGM ³⁸⁰	Inner Mongolia	Chifeng city	Yaogoumen	Yellow-glazed wares.		1055-1125

377 Xiang Chunsong 1991, 33-39.

378 Xiang Chunsong 1991, 33-39.

379 Xiang Chunsong 1991, 33-39.

380 Xiang Chunsong 1991, 33-39.

No.	Abb. name of tomb	Place			Unearthed ceramics	Comparison with dated tombs	Parallel, dated tombs/rough date
		Province	Banner/city/county/district	Township/village			
180	QJG2 ³⁸¹	Inner Mongolia	Chifeng city	Qujiagou	Yellow-glazed ware 1; three-color-glazed wares 2.		1055-1125
181	NGF1 ³⁸²	Inner Mongolia	Chifeng city	Nagefu	Yellow-glazed ware 1; three-color-glazed ware 1; tea-dust green-glazed ware 1.		1055-1125
182	WFG3 ³⁸³	Liaoning	Chaoyang city	Wangfengou village, Dongwujiazi township	White-glazed wares 4.		1055-1125
183	CGC ³⁸⁴	Liaoning	Fuxin	Chenggou villiage	White wares		1055-1125

381 Xiang Chunsong 1991, 33-39.

382 Xiang Chunsong 1991, 33-39.

383 Sun Yutie 1998, 51-2.

384 Hu Jian et al. 1998, 25-28.

No.	Abb. name of tomb	Place			Unearthed ceramics	Comparison with dated tombs	Parallel, dated tombs/rough date
		Province	Banner/city/county/district	Township/village			
184	YS1 ³⁸⁵	Inner Mongolia	Aohan Banner	Yangshan village	White-glazed bowls 3; unglazed grey pottery bottle 2.		1055-1125

385 Shao Guotian et al. 1999, 1-38, 43.

2.2.3 Comparison of Dated and Undated Liao Tombs

The following Table 5 contains a comparison of dated and undated Liao tombs, based on the information comprised above in Table 3 and Table 4.

Table 5 Comparison of Dated and Undated Liao Tombs

Emperor	Date (AD)	Dated tombs and pagodas	Undated tombs
Taizu	923	BS1	
Taizong	942	YLYZ	SZG1, DQTL3, HLB1, HLDT2, ZKC1, QJZ, NZLYZ1, DHG1, HSN, ZKC4, MTYZ2, ZLK, BYD, EBD2, EBD1, GCM, ZJY1, BLC, CYZ, GMC, HLC1, MTYZ1, DQTL1, HLDT1, KPYZ1, QYC, YBS, DST3, ABEGE, HSXM, LBB, SJYM, XFZC, AYC, ZDB, CGWS, SLG3, SLG1, SLG2, WJF, BYTL
Muzong	958	ZDJ	
Muzong	959	FMM	
Jingzong	970-977	YMT7	GDG, BZLG, DEQG, DJWP, AXZ, XTTG3
Shengzong	986	YLYN	BL4, CGB11, DSLT1, QHM4, SQ1, KL3, QCH, BL1, ELC, ZKC2, PJG1, SLC, WDGM, YMT5, YWG, YFC, ZKC3, BXT, SSG4, XJG, XDZ, JZZ
Shengzong	1011	HYM	
Shengzong	1000	LYJ	
Shengzong	1002	SJG1	
Shengzong	1005	WYM	
Shengzong	1014	Pagoda JGS	
Shengzong	1017	HXM	
Shengzong	1018	CGGZ	
Shengzong	1020	GYG	
Shengzong	1026	GZX	
Shengzong	1029	XJM	
Xingzong	1038	JGFR	DYZ3, SLG6, SLG7, DXG1, DSJ, HPC, YMT2, XHD, HTH1, DPC, XNRM, TZM2, TZM3
Xingzong	1043	Pagoda CYBTTG	

Xingzong	1044	Pagoda CYBTDG	
Xingzong	1044	Pagoda WGJGSLT	
Xingzong	1044	QHM1	
Xingzong	1046	LRY	
Xingzong	1049	Pagoda QZBT	
Xingzong	1051	Pagoda BZCT	
Xingzong	1053	WZM	
Daozong	1057	XXW (QHM)	BTYZ, LTL, XDM, MJ1, BL3, HPYZ1, FZZ, XLZZ1, XLZZ2, XLZZ3, XLZZ4, JFYZ, CDM, WLHD, HQYZ6, HQYZ9, PJG2, PJG3, XPJG, GS1, JSF, BTZ, HSMSM, SHZC, MTCZ, QJG1, Hoard SGC, SJZ, SGYZ, TJYZ, YS3, THCZ, TJYZM, WJS1, WJS2, WJZ, XLC5, XSC4, XSG, XLZZ5, XTTG4, XLC, XLG, YLW, YMT2, YMT3, YMT8, YDM, CZ1, DGB, KL6, CKTDS4, DYHT, DZZ, DGBM, FTM, GJT, HXMD, HRBH, JSM, NLZ, PLCZ, QHZ, KL5, WDEARS, WJT, Pagoda YXT, XSC3, XSC10, XSC7, XSC9, HMZ ,GDH1, FLE, ECM, GMZ, CDMM, FJTGX, FJTGD, LMG, ZGZ2, XYFC, CGM, GSZ1, GSZ2, QYD1, QYD2, PSY1, XLZ, SJF, WJD, SBH, SYZ1, SYZ2, DLMA, GSH2, YGM ,QJG2, NGF1, WFG, CGC, YS1,
Daozong	1058	Pagoda DLS	
Daozong	1060	ZKY	
Daozong	1066	SFC	
Daozong	1070	XTM (MWG3)	
Daozong	1072	XFJ	
Daozong	1075	XDW	
Daozong	1075	QDC	
Daozong	1080	KL1	
Daozong	1081	XBTB(MWG4)	
Daozong	1081	BTZM	
Daozong	1089	XXZ	
Daozong	1090	XPL	
Daozong	1090	ZKM	
Daozong	1093	WHW6	
Daozong	1093	ZKZ	

Daozong	1093	ZWZ
Tianzuo	1096	DLZ
Tianzuo	1099	LG
Tianzuo	1099	SWFM
Tianzuo	1108	YLQ
Tianzuo	1109	WKW3
Tianzuo	1109	GSM
Tianzuo	1108	Pagoda CSS
Tianzuo	1111	HSX
Tianzuo	1111	ZTM
Tianzuo	1113	MZW
Tianzuo	1113	DWS
Tianzuo	1115	Pagoda JJS
Tianzuo	1116	ZSQ
Tianzuo	1117	ZGY
Tianzuo	1119	LCS
Tianzuo	1115 ~ 1144	ZSB

CHAPTER 3 CERAMIC SHAPES

The forms in which Liao ceramics occur can be divided into two categories, namely the Khitan style and the Chinese Han style.

Khitan-style ceramics are pottery shapes bearing trademarks of the nomadic Khitan culture and were mainly used by Khitan people. Counting among the ceramics of this category are bag-shaped pilgrim flasks, lugged pilgrim flasks, lugged vases, bowl-mouth bottles, long-neck vases, phoenix-head vases, chicken-leg vases, and oblong-lobed dishes, etc. The bag-shaped pilgrim flask occupies the dominant position in the group of Khitan-style ceramics. (Chart 1)

Chinese Han-style ceramics were the equivalent of other styles of Central China, and were mainly used by Han people. While bowls are the dominant shape of this category, dishes, basins, jars, ewers, spittoons, saucers, boxes, etc. also occur (Chart 1).

3.1 THE BAG-SHAPED PILGRIM FLASK

3.1.1 Introduction

The bag-shaped pilgrim flask, commonly called Jiguanhu (cock's-comb bottle) in Chinese, but also referred to as Pinanghu (leather-bag bottle) or Madenghu (stirrup bottle). It is the most distinctive type among Liao ceramics, and accordingly, it was the first to attract the attention of ceramic historians to this field of study. The bag-shaped pilgrim flask is characterized by its close imitation of leather bags that were commonly used by the Khitan, and by its strong nomadic air. To a certain extent, the history of its emergence, evolution, and deterioration represents a materialized history of the Khitan ethnic group and the Liao dynasty.

Exactly meeting the needs of the nomadic Khitan people, the leather bag was a highly popular container for holding water, milk, or other liquids. Its spout is deliberately designed to be very small in order to avoid an accidental outpour. The leather bag represents the prototype of bag-shaped pilgrim flasks made from other material. Most prominently used among such substances were ceramics, but silver,³⁸⁶ wood,³⁸⁷ and birch bark also occur.

For the most part, the ceramic flask retained the pouch form of the original bag. Accordingly, the raised ridges on its body were modeled upon the seams and stitches of

386 Xiang Chunsong 1985, 94-96.

387 Neimenggu wenwu kaogu yanjiusuo et al. 1993.

the leather prototype. It is important to note that Liao bag-shaped pilgrim flasks differ in quality, running the gamut from porcellaneous white wares to low-fired lead-glazed earthenwares.

A glance at currently available material reveals that the majority of unearthed Liao bag-shaped pilgrim flasks were discovered in Liao tombs located in the centre of the territory of the Liao Empire, i.e. today's Inner Mongolia, and more precisely in the Liaoning and Hebei provinces. The duration of the development process of the bag-shaped pilgrim flask ran through the entire course of the Liao dynasty. Taking into account those Liao tombs which can be accurately attributed to a certain nationality, most samples were recovered from Kithan tombs, especially aristocratic Khitan tombs of the Early Liao. In contrast, the quantity of discoveries of the vessel in Han tombs is very limited. The bag-shaped pilgrim flask is thus often regarded as the representative ceramic form of the Kithan ethnic group.

In their function as funeral objects, the flasks were often buried in pairs. When put to practical use, they were usually connected with a string and hung over the back of a horse. To date, Liao bag-shaped pilgrim flasks were only ever found on Liao kiln sites and in Liao tombs. While they are frequently regarded as special burial objects with no practical function, this opinion has not yet reached the status of a scientific conclusion. An indirect proof for the functional application of the vessel is contained in a mural painting on the eastern wall of a GYY Liao tomb in Chaoyang city, Liaoning province, dated to 1020 AD.³⁸⁸ The illustration contains the image of a bag-shaped pilgrim flask arranged in a banquet scene alongside other objects, like an oblong-lobed dish and a jar, and complete with a servant.

In proportion to the ever growing amount of bag-shaped pilgrim flasks finds, topical discussions became increasingly in-depth. Prior to the 1950s, such debates were almost exclusively led among Japanese scholars.³⁸⁹ In 1908, Torri Ryuzo 鳥居龍藏 and his wife discovered a yellow-glazed bag-shaped pilgrim flask on the banks of the Shira Muren River and named it Tiping (handle vase).³⁹⁰ Later on, Yamashita Taizo 山下泰造, was the first to refer to this vessel as Jiguanhu (cock's-comb bottle). The first exemplar which could be attributed to an accurate location of discovery was a brown-glazed bag-shaped pilgrim flask, unearthed in 1939 from a tomb at the Yebaishou Station in

388 Zhu Zifang & Xu Ji 1983, 168-95.

389 Miyake Soetsu 1940; Shimada Sadahiko 1941.

390 Torri Ryuzo 1936, note 11.

Jianping county, Liaoning province.³⁹¹ Following the Chinese scholar Li Wenxin's 1958 creation of a precedent typological study on the bag-shaped pilgrim flask³⁹², the field became immensely popular with Chinese scientists as well as with researchers from other countries. A multitude of publications appeared, e.g. by Liang Shuqin³⁹³, Li Yufeng³⁹⁴, Yang Jing³⁹⁵, Feng Enxue³⁹⁶, and Zhang Songbai³⁹⁷ from China, or by Tamura Jitsuzo and Hasegawa Michitaka³⁹⁸ from Japan.

The impact of Li Wenxin's typological classifications is reflected by the fact that they were not only significant for all of these writings, but that they remain to be consulted by ceramic historians today.³⁹⁹

Due to deviations from the standard form, Li's classification defined five varieties of the bag-shaped pilgrim flask, which will be briefly introduced in the following.

Type A. Has a round body, the upper section of which is gradually flattened into a crest-shaped, single-perforated carrying tab. It is further characterized by a cylindrical spout and raised ridges curving on the two ends and around the lower part of the body.

Type B. With a flattened body, two squared and perforated carrying tabs, a short cylindrical spout fitted with a stopper, and raised ridges encircling the two flat sides.

Type C. The flattened body is slenderer and more vase-like than Type A and B. It has a very short spout, a loop-handle, and is decorated with raised ridges and bosses.

391 Li Wenxin 1940.

392 Li Wenxin 1958a, 10-22.

393 Liang Shuqin 1981, 147-150.

394 Li Yufeng 1989b, 195-200.

395 Yang Jing 1995b, 195-200.

396 Feng Enxue 1996, 35-42.

397 Zhang Songbai, 1997, 584-91.

398 Hasegawa Michitaka 1978.

399 Mino Yutaka et al. 1973; Mok 1985; Watson 1984.

Type D. Cognizable by a tall and rounder body, a long cylindrical spout, and a loop-handle. It usually comes without raised ridges.

Type E. Has a round, squat body, a cylindrical spout, and raised ridges curving around the body.

As ever more examples of Liao bag-shaped pilgrim flasks have been recently unearthed, our understanding of these particular Liao wares has significantly increased. While Li's classification was only tentative, a more complex picture can now be developed on the basis of the new archeological information and analyses thereof.

3.1.2 Typological Analysis

In my own system of classification, which is based on the form of the handle, bag-shaped pilgrim flasks can be divided into two groups. One is distinguished by a perforated slab-handle, while the other is characterized by a loop-handle.

Group 1: Flasks With a Perforated Slab-handle

The perforated, slab-shaped handle is reminiscent of a cock's-comb. It is usually possible to discern distinctive traces in imitation of the prototypical leather bag on the body. According to the peculiar form of the slab, two types of Group 1 flasks can be distinguished.

Type A. Has a crest-shaped slab-handle. Due to diverse body forms, two subtypes can be identified.

Aa. The front view of the body is trapezoid, the upper part being narrower than the lower one. It displays a short, cylindrical spout. Due to the evolution of this type, it can be further divided into six varieties.

- I. Exhibits a plump body with a flat or concave bottom and a single slab-handle with a single hole. The fully glazed body has vertical straps and raised ridges are curving around its two ends and its lower part. A sample of this type was unearthed from the QJZ tomb. (**Cat. 1**).
- II. Has a slightly slenderer body than Aa . It is further characterized by a marked foot or flat bottom, a single slab-handle with a single hole, and raised ridges curving on the two ends and around the lower part of the fully glazed body. Examples were found in the tombs HLB1, FMM, and DQTL3 (**Cat. 3, Cat. 2, Cat. 4**).
- III. The body is slenderer and flatter than that of Aa . It displays a marked foot, a single slab-handle with a single hole, and little raised ridges on the

body. The glaze almost reaches the bottom of the vessel. Specimens of this type were recovered from the XTTG3 tomb and from a tomb in Sanqidi village in the Huajialaga township, Balin Left Banner, Inner Mongolia (**Cat. 17, Cat. 18**).

- IV. Displays a relatively plump underbelly, a ring-foot, a single-perforated slab-handle in the shape of a crest. It lacks raised ridges on its body and the glaze does not reach the bottom of the vessel. An example was unearthed from the QHM4 tomb (**Cat. 20**).
- V. Has a slender and flattened body, a ring-foot, a single perforated slab-handle with a small crest. There are no raised ridges on the body and the glaze does not reach the bottom of the vessel. A sample was found in the SJG1 tomb (**Cat. 23**).
- VI. Discernible by a slender and flattened body, a ring-foot, and double-perforated slab-handles with smaller crests. The body is not adorned with raised ridges and the glaze does not reach the bottom of the flask. An example was unearthed from the SJG1 tomb (**Cat. 28**).

Ab. The front view of the body is an approximate rectangle with a short cylindrical spout. According to the evolution of this type, it falls into two varieties.

- I. Exhibits a moderately plump body, a flat or concave bottom, and a single slab-handle with a single hole. There are vertical straps on the fully glazed body as well as raised ridges curving around its two ends and its lower part. Examples were unearthed from the SZG1 and FMM tombs (**Cat. 32, Cat. 33**).
- II. Displays a slender and flattened body, a ring-foot, and a single perforated slab-handle with a small crest. Unlike Type Ab I, the body is not adorned with raised ridges on the body, and neither does the glaze reach the bottom of the vessel. Samples were unearthed from the BZLG and DEQG tombs (**Cat. 35, Cat. 39**).

Type B. Without a crest-like, simply curved or squared slab-handle. It has a short cylindrical spout and a flat or concave bottom. Due to the evolution of this type, four varieties of this type can be distinguished.

- I. Displays a plump body and one curved slab-handle with a single hole. Some specimens bear vertical straps on the body, others have raised ridges

curving around its two ends and its lower part. The front view of the body is approximately trapezoid, with an upper part that is narrower than the lower one. Examples were unearthed from the YLB and SSG tombs (**Cat. 47, Cat. 49**).

- II. With a squat body, double-curved slab-handles with double holes. In some cases a stopper is fitted into the spout and raised ridges encircle the two flat sides. Seen from the front the body is almost trapezoid, the upper part being narrower than the lower one. Examples of this type were unearthed from the GDG and YMT7 tombs (**Cat. 52, Cat. 53**).
- III. Exhibits a squat body, double-squared slab-handles with double holes, a stopper for the spout, and raised ridges encircling the two flat sides. The front view of the body is approximately rectangular. An exemplar of this type was found in the AXZ tomb (**Cat. 56**).
- IV. Has a flattened, U-shaped body, and double-squared slab-handles with double holes. In some cases the spout is equipped with a stopper. Small dots imitating stitching and pin-points are often etched into the raised ridges. Examples of this type were discovered in the HXM (**Cat. 68**), GYY (**Cat. 69, Cat. 70**), BL1 (**Cat. 90**), PJG3 (**Cat. 91**), SQ1 (**Cat. 57, Cat. 58**), QCH (**Cat. 59, Cat. 60**), ELC (**Cat. 62, Cat. 63**), GZX (**Cat. 88, Cat. 89**), and YWG (**Cat. 65, Cat. 66**) tombs.

Group 2: Flasks With a Loop-handle

On the basis of four sources, the origin of the loop-handled bag-shaped pilgrim flask can be traced back to a time as early as the Tang dynasty (618-970 AD). For one, a silver ewer with a body in the form of a squat pouch and a flaring ring-foot was discovered at Hejiacun, Xian, Shaanxi⁴⁰⁰. Its spout is fitted with a stopper which is linked to the rear end of the handle with a chain. While there are no raised ridges on the body, it is decorated with the gilded relief of a horse holding a cup in its mouth. Secondly, a type of the pouch-shaped flask exists which is distinguished by its three-color glaze (**Cat. 229, Cat. 230**)⁴⁰¹. Exemplars of this form either have a flat base or a straight ring-foot,

400 Shaanxisheng bowuguan wenguanghui geweihui xiezuo xiaozu 1972, 30-42.

401 At least three pieces are known; one exhibited in the Tokyo National Museum, see Goto Shigeki ed. 1976, 126; one in the Ferris Luboshez Collection, see Harriet 1972, fig. 35; and one formerly in the Mr. and Mrs. Eugene Bernat Collection, sold by Sotheby Parke-Bernet, see Watson 1984, pl.238.

and a “tail” protrudes from the rear end of the handle. Decorations are concentrated mainly on the lower half of the body. Thirdly, a white ware, bearing raised ridges in imitation of leather stitching, was unearthed from a Tang tomb at Xi’an, Shaanxi. (**Cat. 224**)⁴⁰² Fourthly, shards of very fine white porcellaneous quality were discovered at the Xing kiln site at Lincheng, Hebei.⁴⁰³ The result of reconstructive work showed that they had been parts of a pouch-shaped flask. Despite the fact that the vessel could not be completely reassembled, it still could be described as bearing raised ridges and some incised floral designs. Based on this Xing flask as well as on a number of Xing shards decorated with brown dots in iron oxide pigments, Chinese ceramic historian Feng Xianming reassigned a pilgrim flask exhibited in the London Victoria and Albert Museum (**Cat. 220**), previously regarded as a Liao ware, to the Xing kilns.⁴⁰⁴

Owing to variations in the form of the handle, this group can be divided into two types.

Type A. In some cases the horizontal space between the loop-shaped handle and the spout is higher than in other cases. Therefore, Type A falls into two subcategories

Aa. From a horizontal perspective, the handle sits at a higher point of the body than the spout. Due to the evolution of this type, five varieties can be identified.

- I. Has a squat, plump body, a flat or concave base, a cylindrical loop-shaped handle, and raised ridges encircling both sides of its body. Examples of this type were unearthed from the YLYZ and HLDT1 tombs (**Cat. 95, Cat. 96, Cat. 97**).
- II. The body is slightly slenderer and flatter than that of Type Aa. It has a flat or concave base and a dragon-shaped loop-handle. In some cases the body is encircled by raised ridges. Samples were found in the GDG and BZLG tombs (**Cat. 103, Cat. 104**).
- III. Characterized by a slender and flattened body with a ring-foot. Its loop-handle is frequently finger-pinched or string-twisted. Two raised ridges are usually placed horizontally below the spout and the handle. Raised ridges still exist but by different forms on the body. The pouch-shaped body is rather vase-like, with a slightly incurved neck.

402 Li Zhiyan 1972, 34-48.

403 Hebei Lincheng Xingci yanzhi xiaozu 1981, 37-43.

404 Feng Xianming 1981, 49-55.

Examples were recovered from the BL4, SLG6, XSC4, and DSLT1 tombs (**Cat. 112,Cat. 113Cat. 114,Cat. 105,Cat. 106Cat. 107**).

- IV. Compared with Aa , the lower part the body is plumper and the neck is more incurved. It displays a loop-handle in the shape of either a flat ring or a twisted string. Raised ridges still occur at this stage of development, circling around both sides of the body. Specimens were unearthed from the CGB11 and DSLT1 tombs (**Cat. 124,Cat. 125Cat. 126**).
 - V. Exhibits a slender, ovoid body, a ring-foot, and a loop handle in the shape of either a cylindrical ring or a twisted string. At this stage, raised ridges have disappeared from the body and the quality is significantly diminished. Examples of this type were discovered in the WLHD, FJTGX, and CDM tombs (**Cat. 137Cat. 138,Cat. 136,Cat. 139**).
- Ab. Viewed horizontally, the handle and the cylindrical spout are almost at the same height. Five varieties of this type can be distinguished according to its evolution.
- I. Displays a squat, plump body, a flat or concave base, a cylindrical loop-handle, and raised ridges encircling both sides of the body. An example of this type was unearthed from the HLB tomb (**Cat. 144**).
 - II. Has a relatively slender and flat body, a flat base, a cylindrical loop-handle, and raised ridges encircling both sides of the body. Examples of this type were unearthed from the MTYZ1 tomb (**Cat. 146**) and from a tomb at Wusuyigen, Ganggen Sumu, Balin, Right Banner, Inner Mongolia (**Cat. 147**).
 - III. Characterized by a relatively slender and flat body, a flat base or marked foot, a cylindrical loop-handle, and raised ridges encircling both sides of the body. Samples were discovered in the QHM4 tomb and a tomb at Xiaochengzi village, Chagannuo Sumu, Balin Right Banner, Inner Mongolia (**Cat. 149**).
 - IV. With a slender and flattened body, a ring-foot, and a cylindrical or flat ring-shaped loop-handle. The spout is longer than it was at earlier evolutionary stages. Only some raised ridges continue to exist at this point, but they are degenerated to incised lines. Examples were unearthed from the QHM1 and DYZ3 tombs (**Cat. 154,Cat. 160**). The Liaoning Provincial Museum, the British Museum, the Tokyo National Museum, and the Royal

Ontario Museum have collections of this type (**Cat. 162, Cat. 163, Cat. 156, Cat. 157, Cat. 164**).

- V. Compared with the earlier varieties, it exhibits a taller and slimmer round body and the spout, too, is longer and thinner. It has a ring-foot and a finger-pinched loop-handle. Yet, all raised ridges have disappeared from the body at the last stage of evolution. Examples were recovered from the QHM2 (**Cat. 177**), the BL3 (**Cat. 175**), the LTL (**Cat. 179**), the JFYZ (**Cat. 168**), the PJG3 (**Cat. 176**), the XBTB (**Cat. 169**), and the HPYZ (**Cat. 174**) tombs.

Type B. A “tail” protrudes from the rear end of the loop-handle. Due to its evolution, two varieties of this type can be defined.

- I. Viewed horizontally, the The handle sits at a higher point of the vessel than the spout. This type displays a squat body, a short cylindrical spout, and a flaring, marked foot. The Avery Brundage Collection, Asian Art Museum of San Francisco contains a collection of this specimen (**Cat. 219**).
- II. The horizontal heights reached by the handle and the cylindrical spout are almost identical. The body is less plump and the spout is longer than that of Type B . It has a small, flat base and two holes are pierced into the uppermost part of the body, right below the loop. An example was unearthed from the JSF tomb (**Cat. 221**). Furthermore, the Liaoning Provincial Museum owns a collection of such flasks.

In addition to the types listed above, there is a cock-form flask with a loop-handle housed in the Liaoning Provincial Museum (**Cat. 223**). It appears to have been derived from the typical Liao bag-shaped pilgrim flask, except that it is fashioned with a cock’s head instead of the cylindrical spout and that its “tail” was modified into a “real” tail. Dots of brown glaze are applied to indicate feathers, and brown glaze is painted on the vessel to suggest wings. This rare exemplar represents an absolute deviation from the prototype of the leather bag: not does it exhibit skilful craftsmanship in sculptural modeling, but it also has a specially structured inner bottle in the shape of a cylindrical tube.

3.2 THE LUGGED PILGRIM FLASK

3.2.1 Introduction

The lugged pilgrim flask can be traced back in the long history of Chinese ceramics to as early an age as the Chinese Eastern Han dynasty (25-200 AD). An example evidencing

this time frame is a piece of green-glazed stoneware which was unearthed from a tomb at Fanshan, Yuhang County, Zhejiang province, in 1986. It has a short, cylindrical neck, a round, flat body, and a rectangular step-foot. On its shoulders are two vertical stapes and both sides of the body are decorated with incised concentric circles (**Cat. 238**). The lugged pilgrim flask continued to be produced throughout the Northern Qi and Tang dynasties, if distinct by molded designs of Persian origin.⁴⁰⁵ An example of this particular kind is a yellow-glazed porcelain lugged pilgrim flask, unearthed from the tomb of Fancui at Anyang, Henan province, in 1971 and dated to 575 AD. The vessel has a short neck with a straight rim, a pear-shaped, flat body, a perforated handle on each of its shoulders, and a very short mark foot (**Cat. 239**). Liao's lugged pilgrim flask, fashioned to be suitable to the Khitan's nomadic lifestyle, was popular during the Early Liao and possibly even priorly. Its general appearance diverged from the pilgrim flasks fabricated in China proper, displaying a small mouth and base, a short neck, a round, flat body, and two or more lugged handles which were placed in symmetry on either side of the body.

3.2.2 Typological Analysis

The style of Liao's lugged pilgrim flask is highly distinctive. Owing to its evolutionary I have defined three different types in my classification. They are be briefly addressed in the following.

- I. Characterized by a perfectly round, flat body, a lugged handle on each shoulder, a high stand which is as narrow as the mouth, and a relatively long neck. The two flat sides of the vessel are decorated with raised, concentric circles emphasizing the roundness of the body. Most samples are unglazed, grey pottery. They were unearthed from the HSN (**Cat. 231**) and ZKC4 (**Cat. 232**) tombs. Among them, the HSN examples represent the earliest in Liao dynasty. In the ZKC4 exemplars the lug handles are placed further apart than in the HSN wares.
- II. Displays a rectangular, straight mouth, and an oblong flaring foot. Its neck and foot are strikingly shortened, resulting in a great exaggeration of the round flat body. The lugged handles are leather-like and increased in number to a count of six. While the raised concentric circles decorating the body are clearly a continuation of Type , the triangular patterns impressed inside those rings and the scale patterns on the foot evidence an increased interest in decoration among Liao potters. Examples of this type were recovered from the DQTL3 tomb and a tomb at Ningcheng, Inner Mongolia (**Cat. 235, Cat. 234**).

405 Goto Shigeki ed. 1976, pls. 9, 25 and 26.

- III. Has a rectangular, straight mouth, a round, flat body, a grooved body-side, and six lugged handles which are symmetrically placed over the grooves. While its oblong ring-foot is even further reduced than that of Type , its neck is slightly longer. Despite the fact that its concentric circles are rendered in intaglio rather than in relief, and its triangular patterns are simplified to represent combed curved lines forming star-like patterns, this type's decoration is generally close to the Ningcheng-style of Type . An example was unearthed from the GDG tomb (**Cat. 237**).

3.3 THE LUGGED VASE

3.3.1 Introduction

Among the various types of Liao vases, it is the one distinguished by its lug handles (Lugged vase) which appears to own the strongest characteristics of Khitan nomadic mobility. The vessel has a tall, pear-form body with a long, narrow neck which is surmounted by a dish-mouth. On the sides of the body are two pairs of lug handles which are placed one above the other and shaped to resemble buttons or rivets as they occur on leather containers. They are apparently designed to attach strings or thongs as aids for carrying the vessel. A number of this kind of lugged vase was discovered in Liao tombs which can be unquestionably dated to the Liao dynasty. A scene depicted in a Khitan tomb wall painting at Keshiketeng Banner, Inner Mongolia, shows how such vases would have been carried (**Fig. 169**).

The prototype of the Liao lugged vase can be traced back to the Chinese Tang dynasty (618-917AD), an example of which is exhibited in the Center of Asian Art and Culture, Avery Brundage Collection, San Francisco (**Cat. 253**). The white-glazed gray porcellaneous stoneware lugged vase has a swelling, cylindrical, lobed body which slopes sharply into a short, incurved neck. Its mouth is everted and flattened and its flaring foot has a wide rim and a recessed flat base. Two pairs of lug-handles are attached to the upper and lower ends of the narrow lobes. Another prototype is in the Shanghai Museum.

3.3.2 Typological Analysis

Liao's lugged vases show differences in style. According the specific form of the rim, I distinguish two subtypes in my classification.

Type A. Has an everted rim. Due to its evolution, this type can be divided into three different varieties.

- I. Marked by a sloping shoulder and a plump body which lopes into a flat base. An example of this variety was unearthed from the DQTL3 tomb (**Cat. 240**).

- II. Characterized by a large mouth, round shoulders, and a plump body which slopes into a short ring-foot. A sample was discovered in the YLYZ tomb (**Cat. 241**).
- III. Has a smaller mouth than I and II. Furthermore, its rim is slightly everted, the neck shortened, and the relatively slender body slopes into a smaller but higher ring-foot. Specimens of this variety can be found in the collections of the Liaoning Provincial Museum (**Cat. 242**). While the evidence accumulated from unearthed materials suggests that the Liao lugged vase ought to be dated to the early 11th century, Type A III is very likely to be a later modification which falls into the late 11th century, when the style of the lugged vase was being gradually discontinued.

Type B. With a straight rim. The evolution of this type requires that three varieties of it be distinguished.

- I. Characterized by a cursory, expanded dish-mouth, a slenderized and at times elongated neck, round shoulders, and a plump body which slopes down into a shallow ring-foot. The lugged handles represent simple loops. Examples of this type were unearthed from the ZKC1, ZKC4 (**Cat. 243**), and MTYZ2 (**Cat. 244**) tombs, from a tomb in Baoquan village, Balin Left Banner, Inner Mongolia (**Cat. 245**), and a tomb at Bolochi village near Chaoyang city, Liaoning province (**Cat. 246** **Cat. 245**). The Baoquan exemplar bears a “guan” (official) mark on its base. As Baoquan village is located in the proximity of the ruins of Shangjing city (the Supreme Capital of Liao), the vessel uncovered there is likely to have been produced at the Shangjing kiln.⁴⁰⁶
- II. With a smaller and deeper dish-mouth than Type I. The slenderized body slopes into a higher flaring ring-foot with two rectangular holes. The surface is often elaborately stamped and adorned with relief decorations. Seeing as the horizontal lines and raised bosses on the lugs are reminiscent of leather texture and studs respectively, the ceramic vessels are clearly fashioned in imitation of their rawhide origins. Samples were unearthed from the YLYZ (**Cat. 249**) and DST3 tombs (**Cat. 252**), from a tomb at Tuchengzi of Heling'er county, Inner Mongolia (**Cat. 247**), and a tomb at Shantiaomao, Qingshuihe county, Inner Mongolia (**Cat. 248**). The Detroit Institute of Arts also owns a collection, which was donated by Edgar Worch (**Cat. 250**).

406 Wang Qing 1979, 3-14.

3.4 THE BOWL-MOUTH BOTTLE

3.4.1 Introduction

The bowl-mouth bottle inherited the traditional technique of unglazed, burnished earthenware, and in context of form follows the lobing-style vessel of the Chinese Tang dynasty (618-907 AD). The most distinctive features of this vessel are a bowl-shaped mouth, a tapering neck, and a robust, round shoulder and body. A raised line encircling the shoulder separates the body from the neck and mouth. Dense, vertically combed lines often decorate the unburnished lower part of the body. While a small number of bowl-mouth bottles are glazed stoneware, they commonly occur in unburnished earthenware. According to unearthed materials, this type of vessel was mainly distributed around the place of origin of the Khitan ethnic group, and the period of its existence ranges from the pre-Liao to the Early Liao period.

3.4.2 Typological Analysis

On account of divergent forms, three types of the bowl-mouth bottle can be classified.

Type A. Possesses an ovoid body with eight lobes, seven evenly spaced vertical indentations, and a concave base. Due to the evolution of this type, it can be further divided into two varieties.

- I. Marked by a deep mouth. Examples of this variety were unearthed from the DHG1 (Cat. 254), NZLYZ1 (Cat. 256, Cat. 260), and HSN (Cat. 255) tombs.
- II. Has a shallower mouth than Type A I. Samples were recovered from the SZG1 (Cat. 264), EBD1 (Cat. 261) and YLYZ (Cat. 263) tombs.

Type B. Displays an ovoid body without lobes. The evolution of this type requires that three varieties of it are distinguished.

- I. With a long neck, a shallow mouth, a round shoulder, and a false ring-foot with a flat base. An exemplar of this variety was discovered in the HSN tomb (Cat. 265).
- II. Exhibits a long and robust neck, round shoulders, and a short ring-foot. A sample was found in a tomb at Liutiaogou, Beipiao, Liaoning (Cat. 266).
- III. Has a shorter neck than I and II, a robust shoulder, and a ring-foot. An example of this variety was unearthed from the YLYZ tomb (Cat. 267).

Type C. Distinguished by a shallow mouth, a ribbed neck, a carinate shoulder and belly, as well as a false ring-foot with a flat base. An specimen was recovered from the HSN tomb (Cat. 268).

3.5 THE CARINATE-SHOULDER BOTTLE

3.5.1 Introduction

Apart from its name-giving characteristic, the carinate-shoulder bottle commonly features an everted mouth rim, a long and robust neck, a round body, and a ring-foot. In most cases, the bottle is riveted on a flat flange (thumb plate) and has a ring-handle attached to its shoulder. While the bottle's shape is traditionally regarded to represent a jar or a container, it has also been suggested that it was in fact a drinking vessel which originated in Turkic (Shato) metalwork.⁴⁰⁷ This assumption is predicated on the fact that during the long Turkic control of the Kithan, the nomads adopted some oriental customs. After the establishment of their own kingdom, they continued to use Turkic metal wares, often imitating them in cheaper pottery. However, the design of the bottle's handle also bears traces of a Sogdian influence from Central Asia.⁴⁰⁸ Quite a few of its metal parallels was unearthed from Turkic tombs and Liao tombs (**Cat. 269, Cat. 270, Cat. 271**). Another similar silver vessel emerged from a Tang dynasty burial ground in Aohan Banner, Chifeng, Inner Mongolia (**Cat. 273**).⁴⁰⁹ Overall, archaeological excavations yielded more jars without than with handles (**Cat. 283**).⁴¹⁰

3.5.2 Typological Analysis

The Liao ceramic carinate shoulder bottle occurs in various shapes, according to which two different types can be classified.

Type A. Exhibits a single ring-handle and a thumb plate on one side of its shoulder.

Due to its evolution, this type can be further divided into four varieties.

- I. Marked by a globular body. The carinate shoulder rests on the mid-upper part of the vessel. An example of this variety was unearthed from the HLB1 tomb (**Cat. 274**).
- II. Characterized by a hemispherical body. The carinate shoulder lies on the middle part of the vessel. Samples discovered in the NZLYZ1 (**Cat. 277**) and QJZ (**Cat. 278**) tombs.

407 Sun Ji 1996, 263, 260-77.

408 Qi Dongfang 1999, 325-26.

409 Aohanqi wenhuaguan 1978, 117-18.

410 Neimenggu zizhiqu wenhuating & Zhongguo lishi bowuguan 2002, pl.210.

- III. Defined by a hemispherical body with a matching cover. The carinate shoulder rests on the lower part of the vessel. Examples were recovered from the GDG (**Cat. 281**) tomb and a tomb at Pingquan, Hebei province (**Cat. 280**).
- IV. This variety is only half as tall as I, II, and III. It has an oblate body and a matching cover. The carinate shoulder lies on the lower part of the vessel. An example of this kind was unearthed from the HYM tomb (**Cat. 282**).

Type B. Characterized by the lack of a handle. The carinate shoulder sits on the middle part of the vessel. A sample was unearthed from the KPYZ1 tomb (**Cat. 286**). The Liaoning Provincial Museum features a collection of this type of the carinate-shoulder bottle (**Cat. 292**).

3.6 THE LONG-NECK VASE

3.6.1 Introduction

As the name implies, the appearance of the long-neck vase is characterized by a trademark elongate neck and a stretched, ovoid body.

3.6.2 Typological Analysis

Based on divergent forms of the mouth, two types of the long-neck vase can be distinguished.

Type A. What is known as the dish-mouth vase is characterized by the eponymous dish-mouth with a vertical rim, a long, narrow neck, and a remarkable height. It is closely related to the phoenix-head vase; they are analogous in tallness, and they both have a gently curving body contour, and a long, frequently ribbed, neck. This type was widely produced during the Chinese Tang dynasty (618-907AD) and received a delicate treatment by Liao potters. Liao's dish-mouth vase is related to the taller form of Central China's Tang ware, and it was copied by the white-ware potters of Hebei more directly from a metal prototype. However, in Inner Mongolia the vessel evidently constituted an unpopular utilitarian shape. According to different evolutionary stages of Type A, six varieties can be defined.

- I. Marked by a wide, shallow dish-mouth, a slightly incurved long narrow neck, and a plump shoulder. The ovoid body slopes sharply down to a recessed foot with a flat base. This variety of the long-neck vase exemplifies the stylistic transition between late Tang and Early Liao wares. The robust body and flat base are Tang characteristics, while the long narrow neck and large shallow dish-mouth are representative of the Liao tradition. Examples were unearthed from the FMM⁴¹¹

411 Zheng Shaozong 1956, 1-26.

and ZLK (**Cat. 293**) tombs. Furthermore, the Nelson Gallery-Atkins Museum in Kansas city (**Cat. 295**), the Seattle Art Museum (**Cat. 294**), and the Metropolitan Museum of Art in New York (**Cat. 297**) feature collections of this type.

- II. Has a smaller shallow dish-mouth than Type A , as well as a stronger neck. The slender, ovoid body lopes into a shallow ring-foot. Examples of this variety were discovered in the AXZ (**Cat. 298**) and EBD2 (**Cat. 300**) tombs.
- III. In comparison with with Type A , this variety features a smaller but deeper dish-mouth and a smaller flaring ring-foot. The long neck is frequently ribbed. It further exhibits a slanting shoulder, a slender ovoid body, and a contracted belly. Samples were found in the YMT7 (**Cat. 301**), QHM1 (**Cat. 306**), and KL3 (**Cat. 307**) tombs. The Idemitsu Museum of Art (Tokyo) (**Cat. 304**) and the Metropolitan Museum of Art (New York) (**Cat. 303**) feature collections of this variety of the long-neck vase. Notably, the exemplar from YMT7 lacks ribbing on the neck and its body is decorated with floral designs, patterned in a Cizhou-type of the sgraffito technique. In contrast, the QHM1 exemplar does exhibit a ribbed neck but lacks decoration. Examples bearing similar decorations as the vase taken from YMT7 are frequently said to represent Song Cizhou-type wares, but according to my observation, they are more appropriately attached to the Liao kingdom. The sgraffito technique and the bold carving decoration on its body are influenced by Cizhou-type wares. In fact, many examples of Cizhou-type wares are observed to have a form which is overall analogous to Type A III, apart from their stronger bodies, the sometimes angular contour of which is restricted to Song vases only⁴¹²
- IV. In contrast to A I, II, and III, this variety has a lobed rather than a straight rimmed dish-mouth. It further displays a slanting shoulder, and a slender ovoid body which slopes down to a small flat base. The body surface is frequently decorated with sgraffito or bold carving designs. One example, housed in the Tokyo National Museum, is closely related to the Type B phoenix-head vase in context of both the vessel form and the decorative technique. (**Cat. 312,Cat. 313**).
- V. Shows a body shape and decorations similar to Type A , but remains distinguishable by its deeper dish-mouth and shorter neck. An example of this variety was unearthed from a tomb at Buhetehaoda of Bayanerdeng Sumu, Balin Right Banner, Inner Mongolia (**Cat. 314**).

412 Goto Shigeki ed. 1977, pls. 109-110.

- VI. Marked by a deep, cup-shaped mouth, an elongated and slenderized body, a recessed ring-foot, and the fact that the glaze and white slip end unevenly several centimeters above the foot. The majority of specimens is poorly made from rougher materials and shows little craftsmanship. Samples can be found in the Palace Museum (Beijing) (**Cat. 315**), the Lowe Art Museum (University of Miami) (**Cat. 318**), and in some private collections (**Cat. 316**).

Type B. Vase without a dish-mouth which is distinguished by a straight or trumpet-shaped, long neck, a rolled or everted rim, and an ovoid body sloping down to a small base. This type of vessel was derived from a particular kind of a pre-Liao Khitan vase. The model was of unglazed soft earthenware, and decorated with horizontal bands of stamped vertical lines on the lower part of the body and sometimes on the shoulder. Examples of it were discovered at the NZLYZ1 (**Cat. 322**) and DHG1 (**Cat. 321**) tombs.

As the Type B long-neck vase went through several evolutionary stages, three varieties can be defined.

- I. Exhibits a roll-rim and a robust, slightly curved neck which lopes down to the plump shoulder of the ovoid body. It rests on a small flat or concave base. The neck and shoulder are encircled by two raised lines. Examples of this variety were unearthed from the HLB1 (**Cat. 324**) and SZG1 (**Cat. 323**) tombs.
- II. The slightly curved neck is longer than that of Type B I. Other features of this variety include a roll-rim, a slanting shoulder, a slender ovoid body, and a small flat or concave base. The neck and shoulder area is encircled by two to three raised lines. Samples were recovered from the YMT7 (**Cat. 327**), KL3 (**Cat. 329**), CGGZ (**Cat. 328**), and QHM4 (**Cat. 331**) tombs. Some specimens, such as the one housed by the Liaoning Provincial Museum (**Cat. 326**), feature additional raised grooves which represent leather straps. Others have matching covers, such as the exemplars from the CCGZ (**Cat. 328**) and KL3 (**Cat. 329**) tombs.
- III. Characterized by a wide, flaring mouth with an everted rim, a narrow trumpet-shaped long neck, a plump shoulder, and a slenderized and elongated body tapering to a recessed foot with a flat base. A ridge marks the junction between the neck and the shoulder, and unevenly incised lines circle around the neck and the body. Both glaze and slip often end several centimeters above the bottom. This variety occurs among yellow or green-glazed wares. Examples were discovered in the BTYZ (**Cat. 338**), BL3 (**Cat. 339**), and YWG (**Cat. 340**) tombs, as well as in a tomb at the Qiaotou township of Wengniute Banner, Inner Mongolia (**Cat. 333**) and

a tomb at Erguanyingzi of Beizifu township of Aohan Banner of Inner Mongolia (**Cat. 335**).

3.7 THE PHOENIX-HEAD VASE

3.7.1 Introduction

As indicated by its name, the phoenix-head vase is highly reminiscent of the figure of an erect phoenix, raising its head high up on a stretched neck, while extending its chest. The metal prototype of the phoenix-head vase originates in Central Asia; yet, the form was subsequently translated into ceramics in Tang China, where a handle was added to the vase to increase its manageability, coincidentally turning it into a ewer (**Cat. 371, Cat. 372**). On the basis of a Sassanian metal form, Chinese potters of the Tang dynasty (618-907AD) had previously familiarized themselves with the practice of modeling the upper end of a vessel's neck into the shape of a phoenix's head. Tang vessels of this exotic style most often occur in three-colored ware of the 8th century, and sometimes among white stoneware. Their bodies are commonly of a full, rounded or slightly flattened form, standing on a high flaring foot; the phoenix's head serves as the spout. Molded designs of Sassanian origin are elaborately used to decorate the body (**Cat. 372**). After the end of the Tang dynasty, an interest in constructing a phoenix's head on a ceramic vase continued to exist among Chinese potters, but it took to a very different style. As evidenced by an example housed in the British Museum (**Cat. 375**) and roughly dated to a time between the 10th and the 11th century, the carving of the phoenix-head became much more exquisite. In contrast to earlier samples, the beak and the quill are fashioned in a sharp curve. The flaring-foot is low, the neck narrower, more elongated and with fluted lines; the mouth is lobed, representing the crest of the phoenix's head. The piece has been identified as Xicun ware from Guangdong province, and is said to indicate the existence of seahorse contacts between the Liao territory and the far south of China. This post-Tang type appears only among white porcellaneous ware and frequently has a spout rising from the shoulder.

The Liao phoenix-head vase occurs mostly in green or yellow lead glazes. Its common, i.e. a tall, ovoid body with a long ribbed neck, a wide mouth, and a slightly flaring-foot, is reminiscent, not of the Tang phoenix-head ewer, but of the Liao dish-mouth vase. It is uncertain if the Liao phoenix-head vase was a direct descendant of the Tang lead-glazed ewer, its lobed mouth and the curved beak and quill of the phoenix's head, however, seem to relate it to the post-Tang type. Nevertheless, Liao potters produced an adaptation of their own, characterized by a slenderized body and by an exaggeration of the lobed mouth which then seemed too large to be a crest. Moreover, it is marked by the reduction and simplification of the phoenix's head of which only the main features of the beak, the eyes, the ears, and the quill remained. Further archaeological evidence

points towards a possible continuity of style and use. A mural in the ZSQ tomb (d. 1108; buried 1117) at Xuanhua, Hebei province, for instance, which depicts the serving of wine, includes a white (possibly silver) phoenix-head ewer, thus indicating that the form existed at the end of the Liao dynasty. Due to the lack of archaeological evidence, it remains impossible to say with certainty whether or not the Liao vase was directly influenced by a metal form.

In the western side-chamber of a tomb in Chaoyang, two phoenix-head vases, two bag-shaped flasks, and a lidded ewer with a globular body were discovered, all of them glazed in green. The eastern side-chamber contained two more flasks, a cup, and a basin, all of them coated with green glaze as well. It appears that these green-glazed wares make up a complete set for drinking or serving wine, and such a use is further confirmed by the recent discovery of a mural painting in a tomb at Zhaoduba in Chaoyang. Yet, instead of green, the set depicted therein is yellow.

3.7.2 Typological Analysis

Liao's phoenix-head vases occurred in various styles. In my classification, which is based on the form of the neck, two types are distinguished.

Type A. Characterized by ribbed or incised lines on the neck. As it passes through several stages of evolution, three varieties of Type A can be defined.

- I. Marked by a strong body, a broad and robust shoulder, a slightly incurved lower-belly, and a flat base or shallow flaring ring-foot. The slender neck is incised with two lines. The phoenix's head is quite delicately executed with regard to its features, producing a strong sculptural effect. The way in which a pearl is secured in the beak is similar to the Tang type. The crest is fashioned in the form of a shallow, four-lobed dish. Examples were unearthed from the SQ1 (**Cat. 352**) and QCH (**Cat. 351**) tombs.
- II. In contrast to Type I, the body is slender, the shoulder is round, and the ring-foot is smaller but deeper. It has a ribbed neck, a relatively simple imitation of a phoenix's head, and a deep, six-lobed, cupped mouth. This type occurs among both yellow- and green-glazed wares and is frequently decorated with incised peony designs. Samples were discovered in the QHM2 (**Cat. 353**), XXZ (**Cat. 362**), CKTDS4 tombs, as well as in a tomb at Tuquan county, Xing'an league, Inner Mongolia (**Cat. 354**), and at the city wall of Qingzhou, Suoboriga township, Balin Right Banner, Inner Mongolia (**Cat. 355**). While the phoenix's head of the QHM2 example is still rendered in great detail, other examples may

verify the treatment of the phoenix's head, some showing only the beak, the eyes, and the quill.

- III. In comparison to the former two varieties, the body is slenderer, and the ribbed neck thicker. The phoenix-head is fashioned more simply, the round or lobed cup-shaped mouth is even deeper and more expanded, and the overall making is decidedly coarser where both materials and craftsmanship are concerned. Examples were recovered from the XLZZ2 (**Cat. 365**), FZZ (**Cat. 364**), and XPJG (**Cat. 363**) tombs.

Type B. Defined by a neck with a plain surface, lacking any ribs or raised lines. This simplified version of Liao's phoenix-head vase features a shallow, foliated dish-mouth with six lobes instead of only four. The round shoulder slopes down to a flat base. It is often decorated with the sgraffito technique, which is applied to a white ground and coated with an additional green glaze. The Yamato Bunkakan Museum in Nara (**Cat. 369**) and Royal Ontario Museum in Toronto (**Cat. 370**) own collections of this type. While no archaeological evidence Type B has been discovered to date, the formation of the decoration and the clay, which are both very similar to that of basins unearthed from CGB11 (**Cat. 729**) and DSLT1 (**Cat. 727**) make a dating to the 11th century plausible. The Guan Baocong basin collections (**Cat. 732**) may also be consulted as referential pieces.

3.8 THE SPOUTED EWER (PITCHER)

3.8.1 Introduction

The spouted ewer is named after the spout which simplifies the effusion of its contents. As is the case with the majority of Liao pieces, it served as a vessel for tea or wine, and more often than not occurred as part of a set, complete with a large bowl warmer and several cups. Illustrations depicting possible occasions and settings in which a vessel of this group may have been used to serve wine appear in several mural paintings in Liao tombs, e.g. in one discovered in the Zhang family tombs in Xuanhua, Hebei province (**Pl. 362**)⁴¹³. The QCH tomb at Chaoyang yielded a group of vessels which form a similar assemblage: a white-glazed spouted ewer kept inside a warmer and sets of cups with stands.⁴¹⁴

In China, the ceramic spouted ewer can be traced back to the Sui dynasty (581-618 AD), referred to as either Zhuzi, or Zhuhu, or Zhihu in Chinese. Subsequently, during the Tang dynasty (618-907 AD), numerous kiln sites continued to produce spouted ewers. The

413 Hebeisheng wenwu yanjiusuo 2001, pls. 49, 53.

414 Jin Fengyi 1980, pl. 3:3; fig. 31.

Yue kiln sites of Zhejiang province, for instance, fabricated as many as five different types of the vessel, all of which were marked by a characteristic short spout and plump body. In the Five Dynasties and the Song dynasty, the shapes of spouted ewers became more elegant and slenderer. The Liao spouted ewer, despite the fact that it represented Chinese influence and tradition, was highly popular and widely utilized by both Han and Kithan people within the Liao territory.

3.8.2 Typological Analysis

Owing to deviant forms, three types of the Liao spouted ewer can be distinguished.

Type A. Has a round body, a stepped handle which loops from the neck to the shoulder, and a slanting spout. On the basis of divergent forms of the neck and the mouth, two sub-types can be classified.

Aa. Characterized by a robust, cylindrical neck and a straight mouth. The top of the handle is affixed either slightly higher or at the same level as the rim of the mouth. It is a common type of Liao ewer which follows a traditional Chinese form. In Song times, similar types of ceramic ewers, such as Yue, Cizhou-type, and Ding wares etc.⁴¹⁵ were widely produced in Chinese kilns of the Five Dynasties. Variations of the shape require that four varieties of this type of the spouted ewer be distinguished.

- I. Exhibits a strong, short neck, a round shoulder, a globular body, and a ring-foot. Examples of this variety were unearthed from the HLB1 (Cat. 378Cat. 378), DQTL3 (Cat. 379) and FMM (Cat. 387) tombs.
- II. Displays a longer and thinner neck than Aa I, a slightly angular shoulder, a squat body which is often decorated with carved lotus petal designs and rests on a ring-foot. Many exemplars are equipped with a deep-collared, domed cover and an elegant, bud-shaped handle. Samples were discovered in the BL1 (Cat. 398), BL4 (Cat. 393), SJG1 (Cat. 396), QCH (Cat. 399), SQ1 (Cat. 400), CYG3 (Cat. 403), GZX (Cat. 409), YMT22 (Cat. 397) tombs. Further pieces were found in tombs at Yimatu, Beizifu township, Aohan Banner, Inner Mongolia (Cat. 407), at Baixintun, Keyouqian Banner, Inner Mongolia (Cat. 406), and in a

415 For Yue ware, see Zhenjiangshi bowuguan 1977, 90-92, fig. 1; Beijingshi wenwu gongzuodui 1984, 361-381, pl. 18:1; For Ding ware and Cizhou-type ware, see Goto Shigeki ed. 1977, pls. 111. 133. 224.

tomb at Wuqintulu village, Zhangjiayingzi township, Jianping county, Liaoning province (**Cat. 410**).

- III. Distinguished by an even longer and narrower neck than the previously described varieties. It has an angular shoulder, a round or slightly angular lower belly, and a ring-foot. The body is often decorated with carved plantain leaves. Examples of this type were unearthed from the YMT2 (**Cat. 416**), MTYZ1 (**Cat. 419**), TJZZ2 (**Cat. 418**) tombs, a tomb at Xishan of Yemaotai. Faku county, Liaoning province (**Cat. 417**), and a tomb at Yaojiagou, Jinchanggouliang township, Aohan Banner, Inner Mongolia (**Cat. 422**).
 - IV. Has the longest and narrowest neck of all Type Aa varieties, a round shoulder, a ball-shaped belly, and a false circular foot. Except for the spout and the handle, the entire vessel is produced in one molding instrument, examples of which were unearthed at the GWYC kiln site. Meanwhile, the molded designs on the neck and body are formed together. Type Aa III mostly occurs in three-colored lead glaze earthenware. Samples were discovered in Liao tombs in the Chifeng area, namely the QJG1 tomb (**Cat. 420**), and the GWYC kiln site. The Liaoning Provincial Museum has a collection of this kind of vessel (**Cat. 425**).
- Ab. The slender neck is surmounted by a dish-mouth, a slightly flaring spout rises aslant from the shoulder, and the vessel rests on a ring-foot. The top of its handle is attached below the dish-mouth. In accord with variant forms, two varieties of this type can be classified.
- I. Characterized by a conical dish-mouth which is equipped either with a bevel or a flaring rim. Furthermore, it has a narrow, ribbed neck, a round or slightly angular shoulder, and a globular body which is often decorated with carved lotus leaves. Apart from the slender neck and dished mouth, this type is very similar to Aa in Chinese tradition. Samples were unearthed from the GYY (**Cat. 430**) tomb. A green-glazed ewer, housed in the Tokyo National Museum (**Cat. 431**), is an important example for a Liao variation of the traditional Chinese vessel form. Its globular body and handle are Chinese, whereas the narrow, ribbed neck topped by a dished mouth and the application of a green lead glaze are Liao-style trademarks.

- II. Marked by a shallower, trumpet-shaped dishmouth, a longer and thicker unribbed neck, a round shoulder, and an ovoid body. An example of this variety was recovered from the QHM2 (**Cat. 432,Cat. 433**) tomb.

Type B. Discernible by its ovoid body, the lack of a handle, a long narrow neck, a dish-mouth, and a short slanting spout rising from the shoulder. The body slopes down into a slightly flaring foot. While the neck is often ribbed, the body remains largely without decoration, except for one or more relief bands encircling the shoulder. This type of vessel occurs predominantly in white stoneware or porcellaneous ware. It is similar to the Type C long-neck vase as well as to the phoenix-head vase: they all exhibit the characteristic contrast between a long neck and a wide dished or cupped mouth. A very rare ewer, which has a phoenix-head modeled on the top of its long neck while its mouth is elaborated to a crest form (**Cat. 435**)⁴¹⁶, was discovered in a Liao tomb at Luanping, Hebei. It serves as a further source of information in the study of the subtle relationship between the Liao dish-mouthed ewer and phoenix-head vase. Owing to the evolution of Type B, three varieties of it can be defined.

- I. Exhibits a shallow dish-mouth, a slender ribbed neck, a short, slanting spout on the plump shoulder, and an ovoid body sloping down into a ring-foot. An example of this variety was unearthed from YMT7 (**Cat. 437,Cat. 438**).
- II. Has a comparatively deeper dish-mouth, a round or lobed rim, a thicker and shorter ribbed neck, a short spout on the round or slightly angular shoulder, and an ovoid body loping into a ring-foot or into a false foot with a flat base. Samples were discovered in the XTTG3 (**Cat. 441**) and SQ1 (**Cat. 439**)tombs. Collections of this variety can be found in the Royal Ontario Museum in Toronto (**Cat. 443**), the Liaoning Provincial Museum (**Cat. 442**), and the Shanghai Museum.
- III. In comparison with the other two varieties and the cup-shaped mouth is even deeper. Its rim is lobed, the short slanting spout sits on the very round shoulder, and the ovoid body slopes down to a flaring ring-foot. The body is frequently decorated with carved or incised designs. Exemplary pieces were recovered from the XDM (**Cat. 447**) tomb and from a tomb at Tonghua, Jilin province (**Cat. 446**). A corresponding collection is contained in the Palace Museum in Beijing (**Cat. 445**).

416 Zhao Zhihou 1982, 43.

Type C. The body is of a characteristic plant form, variations of which allow a further classification of three sub-types.

Ca. Distinguished by a double-gourd body form, a small mouth, a short spout, a curved handle, and a ring-foot. It represents yet another type of the Liao ewer and has parallels in traditional Chinese ceramics.⁴¹⁷ It occurs in both white and lead-glazed wares and was most popular in the later part of the Liao dynasty. According to its evolution, four varieties of Type C can be defined.

I. Has a small mouth with an incurving rim. Both the upper part with its robust shoulder and the lower part with its round shoulder are shaped into a globular form. A loop-handle connects the curved waist to the lower part. An example of this variety was unearthed from the HLDT2 tomb (**Cat. 452**). This particular specimen is decorated with carved, stylized lotus petal designs, and bears an incised guan (official) inscription on its base.

II. Characterized by a small mouth with a straight rim. Both the upper and the lower parts are fashioned in a globular form and a double-loop handle connects the two sections of the body. Samples were found in the KL1 (1080) (**Cat. 455**) and PJG2 (**Cat. 454**) tombs and in a tomb at Helinhaolai, Naiman Banner, Inner Mongolia (**Cat. 456**).

III. Displays a smaller mouth than the previously described varieties, topped by a straight rim. It has a curved spout and an ovoid upper and globular lower part connected by a double-looped handle. Furthermore, the vessel is of a more elegant appearance and a slenderer shape than its precursors. Examples were discovered in the BL3 (**Cat. 458**) tomb, a tomb at the Shanzuizi commune of Kazuo county, Liaoning province (**Cat. 459**), a tomb at Kunduling, Shuiquan township, Kulun Banner, Inner Mongolia (**Cat. 464**), and a tomb at Yangchang township, Balin Right Banner, Inner Mongolia (**Cat. 470**). Collections of it can be found in the Tokyo National Museum (**Cat. 462**) and the Liaoning Provincial Museum (**Cat. 460, Cat. 461**). Most specimens occur in lead-glazed earthenware. A similar vessel can be found on the stone panel of a Late Liao tomb at Aohan Banner, Inner Mongolia (**Pl. 361**).⁴¹⁸

417 See Gyllensvard 1965, pl.26; Goto Shigeki ed. 1977, pl.25.

418 Xiang Chunsong 1979, 22-32, fig. 11:2.

- IV. Defined by a spout body, the upper part of which is hemispherical. It frequently occurs among white-glazed stoneware with dots of black or brown pigment. An exemplar was unearthed from a tomb at Haoertu township, Balin Left Banner, Inner Mongolia (**Cat. 472**). Collections of this variety can be found in the Liaoning Provincial Museum (**Cat. 473**) and at Guan Baocong (**Cat. 474, Cat. 475**).
- Cb. Characterized by a melon-formed body, a small mouth, a short slanting spout rising from the shoulder, and a looped handle which connects the shoulder and belly. The question whether or not the melon-form ewer should be attached to the Liao kingdom remains unanswered. On the one hand, some ceramic historians regard the ewer as a product of China proper due to its fine craftsmanship, good quality, and the melon-formed body.⁴¹⁹ On the other hand the fact remains that while not a single piece of its remains has ever been discovered at Chinese kilns, ever more remnants have been excavated in Liao territory during recent archaeological investigations. Moreover, the lobed form of the body is not new to traditional Khitan pottery, and the molded, butterfly-shaped ornaments seem to echo a design which can be found on a triangular Liao dish. Furthermore, the evident intention to attain a sculptural effect undoubtedly speaks of Liao taste.

According to several evolution stages, three varieties of Type Cb can be defined.

- I. Distinguished by a lobed belly which is decorated with incised wave designs. Furthermore it has a robust neck sloping upwards to a straight rim, and a short, straight ring-foot. An example of this variety was unearthed from a tomb at Gushanzi village, Sanjia township, Kazuo county, Liaoning province (**Cat. 476**).
- II. Marked by a lobed belly which is adorned with incised wave designs, a short neck with a straight rim, and a short, straight ring-foot. A sample was discovered in a tomb at Xigou village, Linjiadi township, Inner Mongolia (**Cat. 478**).
- III. Features a slightly eight-lobed belly, a carinate shoulder, a short neck with a straight rim, a higher, flaring ring-foot, and a matching cover with a bud-shaped handle. Some exemplars are decorated with chrysanthemum petals on the shoulder and lotus petals around the belly. A number of specimens were recovered from the ZSB (1093) (**Cat. 482**), ZWZ (**Cat. 480**) and SWFM tombs, the latter of which are both datable to 1093. Furthermore, several ewers of this type were found in the

419 Honey 1945, 57, pl.29B; Gray 1953, pl.46; Goto Shigeki ed. 1977, pl.136, p.315.

third cultural layer of the LQW kiln in Beijing, datable to the late 11th century (**Cat. 483, Cat. 485, Cat. 486, Cat. 487**).

In addition to Types Ca and Cb, a small number of individual plant-form types exist. These specimens are altogether more delicately formed, reflecting the natural taste of Liao potters.

- Cc. The HQYZ6 (**Cat. 489**) exemplar has a robust, round, lobed body in the form of a melon and rests on a low ring-foot. The spout is very short and the loop-handle imitates the shape of entwined vines. The front part of the handle separates into three strands attached to each of which is either a molded flower medallion, or a fish, or a butterfly. The mouth rim is depressed to form a circular opening.
- Cd. The vessel recovered from NLZ (**Cat. 491**) is analogous to the one from HQY6 but for the corpus decorations. The body of the NLZ find is not lobed but rather adorned with carved floral designs and incised butterflies. The rim of the depressed mouth is further embellished with small, molded flower medallions, and a molded bird is attached to its top. A corresponding piece was found in the ZKY (**Cat. 492**) tomb, the main difference of which lies in the use of plantain leaf instead of peony designs.
- Ce. Exhibits an oval and lobed body which rests on a low ring-foot. The spout is sharply curved and the front part of the loop-handle, which represents stylized tendrils, separates into three strands. Molded flower medallions are attached to these as well as to the rear end of the handle. An sample was unearthed from a hoard at Sangou village, Chengde city, Hebei province (**Cat. 494**). Collections containing this type can be found in the Datong Municipal Museum of Shanxi province (**Cat. 493**), the Royal Ontario Museum in Toronto (**Cat. 495, Cat. 496**), and at Guan Baocong (**Cat. 498**).
- Cf. A body in the form of a pear distinguishes this type. It lopes upward to a small, incurving mouth with a matching cover. It has a short spout and a looped handle. A collection of such pieces is housed in the Liaoning Provincial Museum. The example displayed in **Cat. 499** is decorated with the same, very exquisitely applied relief designs that can also be found on the Type Aa ewer and the Type B lugged vase. A yellow-glazed shard displaying such a decoration was found at the GWYC kiln. It can be dated to the 10th century, i.e. the early period of the Liao Empire.

Type D. The body of this type occurs in in diverse anthropomorphic or zoomorphic forms. Decorative motifs range from dragon-fish (markara), over mandarin ducks and parrots, to a mythical creature with a human head and the body of a winged fish.

Hence, this particular kind of ewer can be said to fully reflect the interests of Liao potters in modeling zoomorphic forms as well as in achieving a high sculptural effect. Several examples for different sub-types of D are depicted in the following.

- Da. Exhibits the shape of a dragon-fish reclining on a lotus flower, holding its head up high and waiving its tail. A handle in the form of a cloud is attached between the wings and the tail and a pearl in the fish's mouth functions as the spout. A square opening behind the horn is intended for adding water. The lotus flower on which the fish is resting is supported by a solid, round foot. The vessel is made of two molded halves, each of which fully embellished with details in relief, such as scales and raised eyebrows. The ewer is covered with white slip and glossy lead glazes. Indian in origin, the image of the dragon-fish (makara) became prominent in China during the Tang dynasty (618-907AD), and its popularity continued throughout the 12th century. Accordingly, it was a favored motif in the art of the Liao and appeared in various mediums, ranging from metalwork over ceramics to stone carvings. Pottery examples were unearthed from a tomb at the Yusi township, Fuxin city, Liaoning province (**Cat. 503**), and a tomb at Kazuo Central Banner, Inner Mongolia (**Cat. 504**). Corresponding mold instruments and unfinished biscuits can be found at the GWYC kiln site (**Pl. 28**).
- Db. Displays a shape fashioned in imitation of a tall dragon-fish. It is depicted in a U-shaped posture, rather than in the horizontal, long form, standing on two layers of elaborate, overlapping lotus petals, which, in turn, rest on a false, round foot. The handle is attached to the fish's upward pointing tail and to the rear part of the vessel. While the open mouth of the fish serves as the spout, another opening in its tail is designed for filling in water. The relief designs applied to the vessel, as well as the method of its making are, the as same as those of Type Da. Samples were discovered in a tomb at Yushulinzi, Ningcheng county, Inner Mongolia (**Cat. 505**) and another tomb in the same county (**Cat. 505**).
- Dc. Has the same dragon-fish body form as Db, but the fish's head is distinguished by a long curling nose. In this case, too, the open mouth serves as the vessel's spout. The body of the fish is adorned with a pair of wings, and its head and tail are pointing upwards. The vessel, which has another opening on its dorsal side, features a rim in the form of a lotus leaf, and two strands of vines looping from the head to the tail serve as the handle. Exemplars of this type are included in collections of the Palace Museum of Beijing (**Cat. 508**) and the Tokyo National Museum (**Cat. 507**). Notably,

the former exhibition shows pieces of three-color earthenware, while the latter displays white-glazed stoneware.

- Dd. Molded in the shape of a mandarin duck floating on the water. On the bird's back is a mouth shaped in the form of a petal. An arc handle with ripple patterns connects the opening to the tail. The body rests on a false ring-foot. Samples were unearthed from a tomb at Yihefang, Lingyuan county, Liaoning province (**Cat. 511**), and a tomb at Wangjiadianzi, Songshan district, Chifeng city, Inner Mongolia (**Cat. 510**). These pieces are colored with bright yellow and green glaze, and are reminiscent of Tang three-colored animal-shaped vessels. Nevertheless, Dd ceramics must be attributed to Liao on account of the characteristic leaf-formed mouth and vine-like handle.
- De. Appears in the shape of a parrot standing on a piece of rock. While the beak serves as the spout, water can be filled in through an opening between the bird's neck and the ribbon encircling it. The trailing ends of this ribbon form the ewer's handle. The vessel is made from two molded halves, and the mold joints have remained visible. Details, such as the feathers and claws of the parrot, as well as the grass on the rock, are all realistically rendered. An example was found in a tomb at Helinge'er, Inner Mongolia (**Cat. 512**).
- Df. Eccentric type of ewer which combines a human figure and a dragon-fish. At least three specimens are known to exist: a white stoneware piece unearthed at Wulantaohai, Balin Left Banner, Inner Mongolia (**Cat. 514**), another white sample housed in the Eumorfopoulos Collection, and a three-colored ware formerly sold by Sotheby (**Cat. 516**).⁴²⁰ They all show a close resemblance to the Type Dc ewer with regard to the curved body form, the mouth in the form of a lotus leaf, and the vine-like handle. The main difference can be found in the use of the upper body of the human, probably a girl, to replace the dragon head. However, a reduced form of the latter is retained and still serves as the spout. These three peculiar ewers perfectly display how Liao potters modified traditional motifs of Tang art.
- Dg. A rare, three-colored vase in the form of a tortoise which was unearthed at Ningcheng in 1965 (**Cat. 517**).⁴²¹ The animal's head is uplifted to serve as the spout, while its front legs function as simple lugs for suspension. The shell is divided into

420 Feng Yongqian 1981c, 65-71.

421 Feng Yongqian 1981c, 65-71.

three sections by incised concentric circles, etched into each of which are decorative leaves, flowers, and pomegranates respectively. These circles compare to the ones decorating lugged pilgrim flasks, which were popular vessels during the early part of the Liao dynasty.

- Dh. Distinguished by a flattened flask body with a circular profile. A short spout and a handle are attached to its shoulder. It is standing on two layers of overlapping lotus petals, which, in turn, rest on a false round foot. The surface is decorated with elaborately molded flowers, waves, and rolling cloud patterns. It occurs in three-colored lead glaze earthenware. An example is exhibited in the Liaoning Provincial Museum (**Cat. 518**).
- Di. Characterized by a cyprinoid-shaped body with a flaring mouth opening towards its dorsal side. It rests on a false ring-foot, and occurs in three-color-glazed molded earthenware. The Palace Museum in Beijing has a collection of this type (**Cat. 520**).
- Dj. Has a squat, bird-shaped body. An example is displayed in the Royal Ontario Museum, Toronto (**Cat. 521**).
- Dk. Marked by a trumpet-shell-shaped dragon-fish body. A sample of this type was unearthed from a tomb at Kulun Banner, Inner Mongolia (**Cat. 522**).
- Di. Displays yet another version of the dragon-fish body, with a wide openings at the mouth and on the dorsal side, standing on a high flaring ring-foot. It occurs in white-glazed porcelain wares. Examples only exist in private collections (**Cat. 523, Cat. 524**).
- Type E. The inner-tube ewer is special kind of ewer with a straight, narrow tube running inside the body and exiting through the bottom. Hence, there is a downside “mouth” for pouring in water. According to deviant forms, five varieties of this ewer can be distinguished.
- Ea. While the shape of the upper section of the body imitates the stepped cover of a regular ewer mouth, it is not actually open. A short, slanting spout rises from the shoulder and a loop-handle is attached to the opposite side of the body. Examples of this variety were unearthed from the GDG tomb (**Cat. 525**) and from a tomb at Taipingshuang village, Hadayingge township, Balin Left Banner, Inner Mongolia (**Cat. 526**).

- Eb. Defined by a round body, a short spout, and a loop-handle. The false cover has a flattened rim and a bud-shaped handle. An exemplar was discovered in a tomb at Songshan district, Chifeng city, Inner Mongolia (**Cat. 527**).

- Ec. Exhibits a similar shape as the bodies of Type A ewers. It is complete with a stepped false cover. A sample can be observed in a Guan Baocong collection (**Cat. 528**).

- Ed. Marked by the same double-gourd shape observed in the bodies of Type Ca ewers. It occurs in white-glazed stoneware adorned with black, dotted designs. An example of this variety was unearthed from a tomb at Baitaigou Reservoir, Fuxin city, Liaoning province (**Cat. 529**).

- Ee. Has a cock-shaped body, a loop-handle, and a spout in the form of a cock's head. It appears to be a modification of the Liao bag-shaped pilgrim flask, with the cylindrical spout changed to a cock's head and the "tail" to a "real" tail. Dots of brown glaze are applied to indicate feathers, and brown painting to suggest wings. A specimen can be found in the Liaoning Provincial Museum (**Cat. 530**). This rare piece represents an absolute deviation from the leather bag prototype, due, not only to the display of skilful sculptural modeling, but also to the special structure of the inner-bottle with a cylindrical tube.

3.9 THE CHICKEN-LEG VASE

3.9.1 Introduction

The chicken-leg vase has an extremely elongated body, a flat base, and a small mouth. Furthermore, it frequently shows a beveled or slightly flaring rim. Its name is derived from its overall resemblance of a chicken leg. In regard of decorations, the body is either left plain or horizontally fluted, and the shoulder is often incised with Chinese or Khitan characters (i.e. "Qiantong such-and-such year"). It occurs among teadust-green-, brown-, or black-glazed stonewares, many of which contain black specks. The vessel was commonly utilized for fermenting milk and storing wine.

Shards of Liao chicken-leg vases were unearthed from several kiln sites, including the BYGL kiln, the GWYC kiln, the GGT kiln etc. In the production process at BYGL a particular kind of heatproof stick was used to fixate the elongated bottles during firing (**Fig. 5, Pl. 59, Pl. 75, Pl. 212**). Furthermore, instead of placing the vases in saggars, they were stacked on top of each other in order to save space in the kiln. Hence, excess glaze was wiped off the rim of the mouth and the base in order to prevent agglutination.

The chicken-leg vase is regarded as a type of vessel which was specially favored by the Khitan. It continued to be used during the Jin and Yuan dynasties, and was even produced in Chinese kilns, for instance at a production site in Lushan, Henan.⁴²²

3.9.2 Typological Analysis

Two types of the the chicken-leg vase can be classified based on variant forms.

Type A. Characterized by an elongated, cylindrical body which has straight vertical silhouettes. Due to its evolutionary stages, three varieties of Type A can be defined.

- I. Has a plump body and a small mouth with a beveled or flaring rim. Examples were unearthed from the HLDT2 (**Cat. 532**), SQ1 (**Cat. 533**), and YMT22 (**Cat. 534**) tombs.
- II. In comparison with Type A , the body is slenderer and more elongated. A sample of this kind was discovered in the HYM (**Cat. 535**) tomb.
- III. Exhibits a body which is shorter in height and pumper in shape than those of its precursors. An example was found in the WDM (**Cat. 536**) tomb.

Type B. Distinguished by an elongated, ovoid body which gradually tapers to a small flat base. According to the evolution of the body form, four varieties of Type B can be defined.

- I. Displays a plump body and a small mouth with a slightly flaring or beveled rim. Exemplars of this variety were unearthed from the YMT7 (**Cat. 537**) and BL1 (**Cat. 539**) tombs.
- II. Compared with Type B , the body appears relatively slender and elongated. The mouth is small and has a flaring or beveled rim. Examples were recovered from the CGGZ (**Cat. 540**), QHM4 (**Cat. 544**), SQ1 (**Cat. 543**), QHZ (**Cat. 547**), and YMT22 (**Cat. 541**) tombs.
- III. Distinguished by the slenderest body among the four varieties of Type B. It slopes heavily to a smaller base. The mouth is tiny and has a flaring rim. Examples were found in the GS1 (**Cat. 549**) and MTCZ1 (**Cat. 550**) tombs, a tomb at Shuangjing township, Aohan Banner, Inner Mongolia (**Cat. 553**), and a tomb at Shanwan village, Biliutai township, Balin Left Banner, Inner Mongolia (**Cat. 554**). Collections containing this kind of the chicken-leg vase can be found in the Liaoning Provincial

422 Zhao Guanglin & Zhang Ning 1979, 461-471; Li Huibing & Li Zhiyan 1980, 52-60.

Museum (**Cat. 551, Cat. 555, Cat. 556**) and in the Royal Ontario museum in Toronto (**Cat. 552, Cat. 558**).

- IV. Marked by a body which is shorter in height and plumper in shape than the other varieties of Type B. Examples were unearthed from the ZGY (**Cat. 559**), and ZWZ (**Cat. 560**) tombs.

3.10 CHINESE-STYLE VASES

Several varieties of Chinese-style vases were produced and used in Liao territory, all of which sharing a trademark small mouth. According to variant forms, four types of these vases can be classified.

Type A. Has an ovoid body. While the overall form of Type A is highly reminiscent of the chicken-leg vase, the fact that it is also shorter in height and much plumper in shape, rather relates it to the Chinese vessel type meiping (prunus vase). Owing to its evolution, three varieties of Type A can be defined.

- I. Characterized by a straight rim of the mouth and a false ring-foot. Examples of this kind were unearthed from the YMT7 (977) (**Cat. 565**), QHM4 (**Cat. 566**), and CGM tombs. It shows parallels to wares of South China, for instance to the Qingbai exemplar recovered from a tomb near Nanjing, Jiangsu, and dated to 1027.⁴²³ The Qingbai vase is shaped in the same form as the black-glazed vase from QHM4; yet, it is different in regard to decoration, displaying intricately carved designs of floral scrolls. As such it reflects the disparate treatment standards of the same vessel claimed by Liao potters on the one hand and their Chinese counterparts on the other hand.
- II. In comparison with Type A, the body appears plumper. It has an everted mouth rim and a ring-foot. Featuring the characteristic tall, ovoid, tapering body and very small mouth, it is likely to have been derived from the chicken-leg vase. A difference, however, can be detected in its markedly short neck and its relatively elaborate decoration. Liao examples of this type are decorated with floral designs in a Cizhou-type technique. Examples of this type were recovered from the KL1 (1080) (**Cat. 569**) tomb.
- III. Has the slenderest body among the three varieties of Type A, a rolling mouth rim and a slighting flaring, false ring-foot. Samples of this kind are contained in

423 Li Weiran 1963, 343, 339, fig. 2.

collections of the Liaoning Provincial Museum (**Cat. 571, Cat. 572**) and the Capital Museum in Beijing (**Cat. 570**).

Type B. Defined by a plump shoulder which slopes down to a small ring-foot. The maximum diameter of the body can be measured at the shoulder. According to its evolution, two varieties of Type B can be defined.

- I. Exhibits an everted mouth rim, a very plump shoulder, and a flaring ring-foot. Examples were found in the QHM2 (1057) (**Cat. 574**) and KL1 (1080) (**Cat. 575**) tombs.
- II. Has a dish-shaped mouth with a short straight rim, a round shoulder, and small, false ring-foot. The neck is narrower and longer than that of Type B. Samples were unearthed from the CDMM (**Cat. 576**) tomb, from Tomb at Majiagou, Lingyuan county, Liaoning province (**Cat. 577**), Tomb at Yaojiagou, Jinchanggouliang township, Aohan Banner, Inner Mongolia (**Cat. 579**), a tomb at Wushijiazi, Machang township, Jianping county, Liaoning province (**Cat. 578**), and a tomb at Shakengzi, Mutouyingzi township, Aohan Banner, Inner Mongolia (**Cat. 580**). The Wushijiazi exemplar is decorated with black, painted floral designs.

Type C. Characterized by a double-gourd body form and ring-foot. Examples were discovered in the HQY9 (**Cat. 583**) and SHZC (**Cat. 584**) tombs, a tomb at Hurenbaohe village, Xinhui township, Aohan Banner, Inner Mongolia (**Cat. 585**), and a tomb at Yezhushan, Mutouyingzi township, Aohan Banner, Inner Mongolia (**Cat. 586**).

Type D. Two loop-handles connect the neck and the sloping shoulders. The body rests on a ring-foot. The maximum diameter of the body can be measured across the lower part of the belly. Samples were recovered from the XJM (1029) (**Cat. 592**), FJTG3 (**Cat. 593**), PJG3 (**Cat. 595**), HQY9 (**Cat. 594**), and GSZ1 (**Cat. 596**) tombs, and Tomb at Chaoyanggou, Zhangwu county, Liaoning province (**Cat. 591**).

3.11 THE JAR

3.11.1 Introduction

A jar is a food container. While this particular vessel form is commonly attributed to the traditional Chinese style, many varieties of Liao jars also appear. The majority of the latter are recognizable by their trademarks of a large mouth, short neck, round body, and ring-foot or flat base.

3.11.2 Typological Analysis

Based on variant forms of the body, three types of Liao jars can be classified.

Type A. The maximal diameter of this kind can be measured across the middle part of its belly. According to the distinct forms of the neck, it can be further divided into two sub-types.

Aa. Distinguished by a relatively high neck. Due to its evolutionary stages, four varieties of Type Aa can be classified.

I. Has a straight neck and an oblate, spherical body which is lobed in some cases. It sits on either a short or a false ring-foot. Examples of this kind were found in the DQTL3 (**Cat. 601, Cat. 602**), HLB1 (**Cat. 599**), and FMM (**Cat. 603**) tombs, as well as in Tomb Chaoyanggou, Zhangwu city, Liaoning province (**Cat. 600**).

II. The neck is shorter than that of Type Aa. Furthermore, it has a globular body as well as a short, flaring ring-foot. A sample was unearthed from the CGGZ tomb (**Cat. 604**).

III. Features an everted rim, a slender, ovoid body, and a short, flaring ring-foot. An example of this kind was recovered from the XLZZ1 tomb (**Cat. 606**).

IV. Distinct by its tallness, it usually measures between 30 cm and 46 cm in height. The thickly potted, ovoid body rests on a flat base. It has a short neck and a markedly thick rolled mouth rim. This type is most often decorated with a wide horizontal band of peony designs, executed on white slip by incision, sgraffito, or incision plus iron-black painting. Examples were discovered in tombs or sites of Songshan district, Chifeng city, Inner Mongolia (**Cat. 612**), at Kalaqin Banner, Inner Mongolia (**Cat. 611**), at Aohan Banner, Inner Mongolia (**Cat. 613**), and at the Taipingchi Commune, Chifeng city, Inner Mongolia (**Cat. 615**). A number of specimens is contained in collections of the Liaoning Provincial Museum (**Cat. 614**), the Center of Asian Art and Culture in San Francisco (**Cat. 616**), the Idemitsu Art Gallery in Tokyo (**Cat. 618**), and the Nelson-Atkins Gallery in Kansas (**Cat. 622**). The vessel type is known to have been produced by the kilns of GWYC (**Cat. 619**).

Ab. Defined by a short neck. Due to its evolution, two varieties of Type Ab can be classified.

- I. Exhibits a big mouth, an oblate, spherical body, and a short ring-foot. In some cases the body is lobed. Examples were found in the FMM (**Cat. 624**), YLYZ (**Cat. 627**), XHD (**Cat. 626**), and HJM (1056) tombs.
- II. Has a smaller mouth than its precursor and a globular body which is lobed in some cases. It rest on either a short ring-foot or a false foot. Some pieces are equipped with a matching cover. Examples were unearthed from the HYM (**Cat. 629**), TZM2 (**Cat. 634**), and GYY (**Cat. 630**) tombs.

Type B. The maximal diameter of this type can be measured across its shoulder, i.e. on the upper part of the belly. According to distinct forms of the neck, this type can be divided into four sub-types.

- Ba. Marked by a relatively high straight neck and a small mouth. According to the evolution of its form, two varieties of this sub-type can be distinguished.
 - I. Displays a robust shoulder and an ovoid body resting on a short ring-foot. An example was unearthed from the HLB1 tomb (**Cat. 635**).
 - II. Exhibits a short, oblate body, an everted mouth rim and a ring-foot. An exemplar of this variety was found in the XHD tomb (**Cat. 637**).
- Bb. Characterized by a short neck and a ring-foot. Due to the evolution of its form, two varieties of this type can be classified.
 - I. With a large mouth, a round, robust shoulder, and body sloping down to a small, short ring-foot. The full, stout vessel form is not a far cry from Tang-style ceramics; it compares well with a type of Tang jar which the Japanese named Mannenko (万年罐 myriad year jar).⁴²⁴ Samples were discovered in the YLYZ (**Cat. 638**) and NZLYZ1 (**Cat. 643**) tombs.
 - II. Features a carinate shoulder, straight body sides, and a small but high ring-foot. Examples of this variety were unearthed from the QHM2 (**Cat. 646**), QDC (**Cat. 648**), and SHZC (**Cat. 651**) tombs. Specimens can be observed in the Liaoning Provincial Museum (**Cat. 652**) and at Guan Baocong (**Cat. 650**).

424 Goto Shigeki ed. 1976, pls. 48-51.

- Bc. Defined by a short neck, a carinate shoulder, and a ring-foot. As the form runs through several stages of evolution, two varieties of this type can be identified.
- I. Displays a small mouth, a slightly carinate shoulder, and a comparatively low-positioned belly resting on a ring-foot. It occurs mostly in white porcelain ware and with carved designs of overlapping lotus petals on the body. Examples were unearthed from the HYM (**Cat. 653**) and SJG1 (**Cat. 654**) tombs, the JGS pagoda (**Cat. 655**), and the LQW kiln site (**Cat. 661**).
 - II. Exhibits a notably carinate shoulder. Examples were found in the YS1 (**Cat. 666**) and WZM (**Cat. 667**) tombs, and at the LQW kiln site (**Cat. 662**, **Cat. 663**). Collections of this variety can be found at the Liaoning Provincial Museum (**Cat. 664**) and at Guan Baocong (**Cat. 668**).
- Bd. Marked by a short neck, a robust, round shoulder, and a small, flat base. According to the evolution of its form, three varieties of this type can be distinguished.
- I. Has a robust body which slopes down into a flat base. An example was unearthed from the YLYZ tomb (**Cat. 670**).
 - II. Shows a slightly incurved belly and is sometimes equipped with a matching cover with a flattened rim. One example was discovered in the XBTB (MWG4) tomb (**Cat. 671**), the body of which is decorated with carved designs of overlapping lotus petals.
 - III. Distinguished by a large mouth and a robust body which lopes down into a small, flat base. This type frequently occurs in white-glazed stoneware painted with brown or black iron. Examples were found at the GWYC kiln site, in a tomb at Jiliyingzi, Shuangjingzi township, Aohan Banner, Inner Mongolia (**Cat. 673**), and at sites in Chifeng city, Inner Mongolia (**Cat. 678**, **Cat. 679**). Specimen exemplars are contained in collections of the Shanghai Museum (**Cat. 674**, **Cat. 676**), the Kazuo Museum in Liaoning province (**Cat. 677**), in the Metropolitan Museum of Art in New York (**Cat. 675**), and at Guan Baocong (**Cat. 672**).
- Type C. The maximum diameter of this type can be measured across the lower part of the belly. The vessel has a small mouth, a straight rim, and a squat body. The diameter of the base exceeds that of the mouth. According to variant forms of the base, two sub-types of Type C can be classified.

Ca. Characterized by a ring-foot. According to the evolution of its forms, two varieties can be defined.

I. Marked by an ovoid body. A green-glazed example can be found at the Center of Asian Art and Culture, Avery Brundage Collection, San Francisco, California (**Cat. 682**).

II. The body is shorter than that of Type Ca . A sample was unearthed from the XTM (MWG3) tomb (**Cat. 683**).

Cb. Defined by a flat base. An example was discovered in the JSM tomb (**Cat. 686**).

Type D. Characterized by two handles. According to its distinct forms, two varieties of Type D can be defined.

Da. The maximal diameter of this kind of vessel can be measured across its shoulder. The form of the jar is similar to that of Type Ab , with the exception of a pair of small loop-handles on its shoulder. The BYGL kiln at Lindong is known to have produced these small jars in black glaze;⁴²⁵ however, many existing examples are decorated with simple designs executed in a Cizhou painting technique which can be dated to the Late Liao dynasty, i.e. in black or brown on white slip. Two such exemplars were discovered at Nailingao, Aohan Banner, Inner Mongolia (**Cat. 687, Cat. 688**), together with a typical Khitan long-neck vase, which represent an important indicator for a Liao dating.

Db. In this case it is the lower part of the belly which measures the largest in diameter. While its form compares to Type Ca , it bears a pair of small loop-handles on its shoulder. Examples were discovered at the GWYC kiln site and in the PJG tomb. It can be observed in collections of the Liaoning Provincial Museum (**Cat. 694, Cat. 695**) and at Guan Baocong (**Cat. 689, Cat. 690, Cat. 692**).

3.12 THE BASIN

3.12.1 Introduction

The basin was a commonplace device used for washing the hands or the face. Liao ceramic basins often occur in low-fired lead-glazed earthenware, following forms of the

425 Li Wenxin 1958b, 97-107; Li Wenxin 1958a, 10-22.

traditional Chinese style, but a number of brass basins have also been unearthed from Liao tombs. In the ZWY tomb, a yellow-glazed basin was found sitting on a piece of wooden furniture, a position indicative of the vessel's function in bodily hygiene. Commonly, the mouth-diameter of the Liao ceramic basin measures between 25 cm and 38 cm.

3.12.2 Typological Analysis

According to divergent forms, two types of the Liao ceramic basin can be classified.

Type A. Marked by a ring-foot. According to the evolution of the form, four varieties of this type can be defined.

- I. Displays an everted mouth rim and a robust belly, the lower part of which curves outwards. It rests either on a big ring-foot or on false ring-foot with an incurved base. Examples were unearthed from the DQTL3 (**Cat. 697**) and QHZ (**Cat. 698**) tombs.
- II. Exhibits an everted mouth rim and a curved belly which slopes down to a small ring-foot. Examples of this variety were discovered in the SQ1 (**Cat. 699**), DXG1 (**Cat. 700**), FMM (**Cat. 701**), and CGGZ (**Cat. 702**) tombs.
- III. Has a flattened mouth rim and a slightly carinate belly which runs down either into a small but high ring-foot or into a false ring-foot with incurved base. Samples were found in the JFYZ (**Cat. 704**), BL3 (**Cat. 703**), XLZZ1 (**Cat. 710**), QHM2 (**Cat. 705**) tombs, and at KJZZ2 (**Cat. 706**) tomb. Specimen exemplars are contained in collections of the Liaoning Provincial Museum (**Cat. 713**), of the Liaoning Tieling qunzhong yishuguan (**Cat. 712**) and at Guan Baocong (**Cat. 711, Cat. 709**).
- IV. Features a flattened mouth rim and a heavily carinate belly sloping down into a small ring-foot. Examples were recovered from the ZWZ (**Cat. 716**) and ZSB (**Cat. 715**) tombs.

Type B. Defined by a flat base. Due to the evolution of its form, four varieties of Type B can be distinguished.

- I. Exhibits straight or slightly curved sides, a straight rim, and a big, flat base. Examples of this variety were unearthed from the DQTL3 (**Cat. 718**) and QCH (**Cat. 719**) tombs. Samples are also contained in a collection at Guan Baocong (**Cat. 720**). A golden exemplar of said shape has been discovered in the CGGZ tomb (**Cat. 721**).

- II. Has an everted rim, curved sides, and a smaller concave or flat base than Type B I. Several exemplars were found in the YMT22 (Cat. 722) and HTH1 (Cat. 723) tombs.
- III. Marked by a flattened mouth rim, sloping sides and a smaller flat base than B I and B II. This type of basin most frequently occurs in white-glazed, reddish earthenware with decorations executed in sgraffito and accented with green pigments. These wares form a small but significant group among Liao ceramics which, in addition to large basins, also includes long-neck vases, phoenix-head vases, jars, and spittoons. In all likelihood, these vessels are products of the NSY site in Balin Left Banner, Inner Mongolia. Examples of Type B III basins were unearthed from the DSLT1 (Cat. 727), CGB11 (Cat. 729), XHD (Cat. 725), LBB (Cat. 724), CKTDS4 (Cat. 731), and YMT2 (Cat. 738) tombs. Other finds were made in several Inner Mongolian tombs, i.e. at Beishan, Aluke'erqin Banner (Cat. 730), a tomb at Yimatu village, Beizifu township, Aohan Banner (Cat. 734), a tomb at Shuangsheng village, Longchang township, Balin Left Banner (Cat. 735), a tomb at Yousheng village, Baiyin'aobao township, Balin Left Banner (Cat. 741), and a tomb at Heping Dadui, Dayingzi township, Linxi county (Cat. 726). Exemplars are contained in collections of the Liaoning Provincial Museum (Cat. 738, Cat. 739, Cat. 743) and of Guan Baocong (Cat. 728, Cat. 732, Cat. 742).
- IV. Displays a rolled rim, a curved belly, and the smallest flat base among the varieties of Type B. Examples were discovered in the XSC7 (Cat. 750), WJS1 (Cat. 749), and FJTGX (Cat. 748) tombs.

3.13 THE SPITTOON

3.13.1 Introduction

In Chinese, the spittoon is generally referred to as Zhadou, but the appellations Tuohu or Tuoyu also occur. The vessel is named after its function as a collecting tray for fish or animal bones accruing during dinner. While the spittoon is generally believed to be a traditional Chinese-style utensil, it also occurred in Liao ceramics and in metals like silver, and was widely used in the Liao Empire (Cat. 751, Cat. 752, Cat. 753).

3.13.2 Typological Analysis

The cognizable characteristics of the spittoon comprise a broad trumpet-mouth, a narrow neck, an oblate belly, and a ring-foot. According to diverging heights of the spittoons' feet, four types of can be distinguished.

Type A. Identifiable by a short ring-foot or false ring-foot. According to the evolution of its form, Type A it can be divided into six varieties.

- I. Displays a narrow neck. The diameter of the mouth slightly exceeds that of the belly. An example was discovered in the DQTL3 (**Cat. 754**) and XHD (**Cat. 755**) tombs.
- II. Has a broader neck than Type A . The diameter of the mouth also exceeds that of the belly. A sample was recovered from the ELC tomb (**Cat. 756**).
- III. With a neck as broad as that of Type A , it displays a slightly carinate shoulder. Several exemplars of this variety were unearthed from the YWG (**Cat. 758**) and QHM4 (**Cat. 761**) tombs, as well as from a tomb at Kangjiazhangzi, Jianping city, Liaoning province (**Cat. 757**).
- IV. Cognizable by a neck which is more expanded than those of its precursors. The diameter of the mouth exceeds that of the belly. An example was recovered from XSC4 (**Cat. 763**).
- V. Has the most expanded neck among all Type A variations of the spittoon. The belly is oblate and its diameter is decidedly exceeded by that of the mouth. Samples were unearthed from the PJG3 (**Cat. 765**), TJYZ (**Cat. 766**), XLZZ3 (**Cat. 770**), XLZZ4 (**Cat. 775**), ZWZ (**Cat. 778**), ZSB (**Cat. 779**), ZKZ (**Cat. 780**), and ZSQ (**Cat. 777**) tombs. Specimen exemplars can be found in collections of the Liaoning Provincial Museum (**Cat. 768, Cat. 769**), the Aohan Banner Museum in Inner Mongolia (**Cat. 774**), the Palace Museum in Beijing (**Cat. 776**), and at Guan Baocong (**Cat. 771, Cat. 772, Cat. 773**).
- VI. Marked by an ovoid belly. The diameter of the mouth is decidedly larger than that of the belly. Examples were found in the XDM (**Cat. 782**) and HPYZ1 (**Cat. 783**) tombs.

Type B. Defined by a high, flaring ring-foot. Owing to the evolution of its form, Type B can be divided into two varieties.

- I. Cognizable by a narrow neck and slightly curved mouth sides. An example of this variety was unearthed from the QCH (**Cat. 784**) tomb.
- II. Displays a broader neck and a deeper belly than its precursor, as well as a slopping mouth with a straight rim. A sample was recovered from DSLT1 (**Cat. 785**). Guan Baocong has collections of this variety (**Cat. 787, Cat. 788**).

Type C. Characterized by a flat base. As the form of the body runs through several stages of evolution, three varieties of Type C can be distinguished.

- I. Shows a narrow neck and an oblate belly. An example was found in the HYM (**Cat. 789**) tomb.
- II. With a broader neck and a bigger base than Type C. The belly of this variety is globular. A sample was located in a tomb at Xinlin village, Xianfeng township, Aluke'erqin Banner, Inner Mongolia (**Cat. 791**).
- III. Exhibits an ovoid belly. An example of this variety was detected in a tomb at Erbadi village, Yangchang township, Balin Right Banner, Inner Mongolia (**Cat. 792**).

Type D. Characterized by a lobed flaring mouth. One white-glazed example is contained in a collection of the Liaoning Provincial Museum (**Cat. 793**).

3.14 THE SAUCER

3.14.1 Introduction

The function of a saucers is to steady the cups of a tea or wine drinking set.

Archaeological evidence shows that ceramic were produced at a time as early as the Chinese Dong Jin dynasty (317-420 AD), and to have prevailed during the Chinese Tang dynasty (618-907AD). While the Liao ceramic saucer has inherited a traditional Chinese form, it distinguishes itself by characteristic materials and a specific production technique.

3.14.2 Typological Analysis

According to varying forms of the saucer, it is possible to define five types of it.

Type A. Marked by a simple dish form and a short ring-foot. Due to its evolution, two varieties of Type A can be distinguished.

- I. With sloping sides, a short, straight rim, and a concaved base. Examples of this variety were unearthed from the DQTL3 (**Cat. 794**) and HLB1 (**Cat. 795Cat. 796**) tombs, as well as from a tomb at the Yebaishou Station of Jianping city, Liaoning province (**Cat. 797**).
- II. Displays curved sides, a short, straight rim, and raised circular ridges on the interior surface. Samples were detected in the QCH (**Cat. 799**), ZJYZ (**Cat. 800**) and JCY (**Cat. 798**) tombs.

Type B. Characterized by a circular stage rising from the center of the saucer, which has a short, straight rim to hold the foot of the cup firmly in place. On account of the evolution of its form, Type B can be divided into three varieties.

- I. Exhibits curved sides, a big, high ring-foot, and a raised base. An exemplar was recovered from the DQTL3 tomb (**Cat. 804**).
- II. Has a larger and higher circular stage than Type B I. An example of this variety was discovered in the YLYN tomb (**Cat. 808**).
- III. Displays carinate sides, a small, short ring-foot, and a flat base which is punched at its center. The circular stage has a foliate lib. Samples were unearthed from SQ1 (**Cat. 806**) and from a tomb at Hadatu village, Hadayingge township, Balin Left Banner, Inner Mongolia (**Cat. 805**).

Type C. Distinguished by flaring saucer sides and a cup-shaped ring which rises from the center of the piece to hold the foot of the cup firmly in place. According to variant forms, three sub-types can be classified.

- Ca. Has a ring-foot with a flat base. On account of the evolution of the form, Type Ca can be divided into two varieties.
 - I. Features an inner cup with an everted rim and a short ring-foot. Examples were located in the BL4 (**Cat. 809**) and HXM (**Cat. 810**) tombs.
 - II. The inner cup has an incurving rim. The saucer is shallower than type Ca and rests on a flaring, comparatively high ring-foot. In some cases the sides are six-lobed. Samples of this variety were unearthed from the XLZZ4 (**Cat. 817**), ZWZ (**Cat. 814**), ZSB (**Cat. 813**), and BTYZ (**Cat. 818**) tombs. Several exemplars are contained in collections of the Liaoning Provincial Museum (**Cat. 822, Cat. 824**), the Chifeng Municipal Museum (**Cat. 823**), and at Guan Baocong (**Cat. 820, Cat. 821**).
- Cb. Marked by a ring-foot with a hollow base. The inner cup is joined to the ring-foot. An example was recovered from the JFYZ tomb (**Cat. 826**).

Type D. Characterized by a very shallow body and a short, straight ring rising from the center of the saucer to hold the foot of the cup firmly in place. Examples can be observed in **Cat. 828** and **Cat. 830**.

Type E. Marked by a high, straight ring rising from the center of the saucer to hold the foot of the cup firmly in place, and a high ring-foot. A green-glazed example was discovered at the LQW kiln site (**Cat. 831**).

3.15 THE RING-FOOT BOWL

The ring-foot is the eponymous characteristic of this traditional Chinese utensil. It was widely used in Liao territory by both Khitan and Han people. Furthermore, as evidenced by the great quantity of ring-foot dish shards found at major Liao kiln sites, it made up a large proportion of Liao ceramics. The finds of shards discovered at the LQW, GWYC, and GGT kilns show that ring-foot bowls were mostly large vessels with curved contours. As such they display familiar trademarks of traditional Chinese ceramics.

Due to variations in its form, three types of the Liao ring-foot bowl can be distinguished.

Type A. Defined by flaring sides and a straight rim. Two sub-types must be classified on account of divergences of the overall form.

Aa. The overall form is simple and round. According to its evolution, four varieties of Type Aa can be defined.

I. Marked by a sloping contour and a short, big ring-foot. Examples of this kind were unearthed from the DQTL3 (**Cat. 832**) and SZG1 (**Cat. 833**) tombs, as well as from a tomb at Sunjiawan, Chaoyang city, Inner Mongolia (**Cat. 834**).

II. Exhibits a slightly outcurved contour. Compared with its precursor it shows a deeper belly and a smaller and higher ring-foot. Samples were recovered from the BL1 (**Cat. 835**), SLG6 (**Cat. 836**), CGWS (**Cat. 837**), GZX (**Cat. 838**), XHD (**Cat. 840**), YWG (**Cat. 841**), DXG1 (**Cat. 842**), YMT8 (**Cat. 843**), AXZ (**Cat. 846**), CKTDS4 (**Cat. 847**), KJZZ2 (**Cat. 848**), ELC (**Cat. 849**), ZKY (**Cat. 850**), and CGC (**Cat. 851**) tombs.

III. Displays a somewhat outcurved contour and a small ring-foot. Examples were discovered in the QHZ (**Cat. 855**), XNRM (**Cat. 856**), YS3 (**Cat. 857**), XSC4 (**Cat. 858**), CGB11 (**Cat. 859**), GSZ2 (**Cat. 860**), FJTGX (**Cat. 861**), GMZ (**Cat. 862**), ZDB (**Cat. 863**), QDC (**Cat. 864**), MJ1 (**Cat. 865**), KL6 (**Cat. 866**), YMT8 (**Cat. 867**), HQYZ3 (**Cat. 868**), XFJ (**Cat. 877**), and CDMM (**Cat. 879**) tombs.

- IV. Characterized by a lightly outcurved silhouette, a deep belly, and a small, short ring-foot. Examples were detected in the TJYZ (**Cat. 887**), CKTDS4 (**Cat. 888**), WFG (**Cat. 889**), **Cat. 890**), JFYZ (**Cat. 892**), **Cat. 895**), MJ1 (**Cat. 891**), and XFJ (1072) (**Cat. 886**) tombs.
- Ab. Defined by an overall circular, foliated form. Owing to its evolution, there are three varieties of this type.
- I. Has a slightly outcurved silhouette and a short ring-foot. Samples were found in the ZLK (**Cat. 896**), YLYZ (**Cat. 897**), HLB1 (**Cat. 898**), YWG (**Cat. 902**) and CYG2 (**Cat. 903**) tombs.
- II. Marked by a heavily outcurved contour and a ring-foot higher which is higher than that of its forerunner. Examples of this variety were unearthed from the HYM (**Cat. 904**) and WZM (**Cat. 905**) tombs.
- III. Distinguished by a heavily outcurved contour, a shallower belly than that of Type Ab II, and a comparatively high ring-foot. Examples were discovered in the PJG3 (**Cat. 907**), CDM (**Cat. 909**), GS1 (**Cat. 910**) and ZWZ (**Cat. 911**) tombs, as well as in the CYBTDG (**Cat. 908**) pagoda.

Type B. Defined by flaring sides, an everted rim, and a low foot. Two sub-types must be classified on account of divergences of the overall form.

- Ba. The overall shape is simple and round. Due to its evolution, five varieties of Type Ba can be defined.
- I. Has a slightly outcurved contour and a relatively high ring-foot. Examples were located in the BS1 (**Cat. 912**) and SJG1 (**Cat. 913**) tombs.
- II. Exhibits a lightly outcurved silhouette, and a shorter ring-foot and shallower belly than its precursor. Samples were unearthed from the ABEGE (**Cat. 914**), YMT22 (**Cat. 915**), ZJY1 (**Cat. 916**), XDM (**Cat. 918**), BL4 (**Cat. 919**), XSC9 (**Cat. 920**), HQYZ6 (**Cat. 921**), BTZ (**Cat. 922**), WJF (**Cat. 923**), FJTGX (**Cat. 924**), and YS1 (**Cat. 926**) tombs.
- III. Displays a slightly outcurved contour, as well as a shallower belly and smaller ring-foot than Types Ba I and II. Samples of this variety were unearthed from the

WLHD (Cat. 927), YWG (Cat. 928), CDMM (Cat. 929), ZWZ (Cat. 930), and KL6 (Cat. 933) tombs.

IV. Shows an outcurved contour, a deep belly, and higher ring-foot than the other varieties of Ba. Examples were detected in the MJ1 (Cat. 934) XHD (Cat. 935), and FJTGX (Cat. 936) tombs.

V. Distinguished by a strongly outcurved contour, a deep belly, and a small ring-foot. Examples of this variety were recovered from the ZWZ (Cat. 937) and ZKZ (Cat. 938) tombs.

Bb. Characterized by an overall form which is circular and foliated. According to its evolution, three varieties of Type Bb can be defined.

I. Has a strongly outcurved silhouette and rests on a short ring-foot. Example of this variety were unearthed from the HLDT2 (Cat. 945) and GMZ (Cat. 944) tombs.

II. Marked by an outcurved contour. It has a shallower belly and a higher ring-foot than Type Bb I. Samples were located in the BL4 (Cat. 946) and YLYN (Cat. 947) tombs.

III. Features a slightly outcurved profile, and a shallower belly and higher ring-foot than Type Bb II. Examples were recovered from the CGB11 (Cat. 948), QCH (Cat. 949), ZGY (Cat. 950), and ZWZ (Cat. 951) tombs.

Type C. Characterized by straight sides and a straight rim. Two sub-types must be classified on account of divergent overall forms.

Ca. The overall form is simple and round. According to its evolution, five varieties of Type Ca can be defined.

I. Marked by a strongly outcurved contour, a deep belly, and a big ring-foot. Examples were discovered in the SJG1 (Cat. 952) and JFYZ (Cat. 956) tombs.

II. Defined by a slightly outcurved contour, a deep belly, and a short, small ring-foot. Samples of this variety were found in the BL4 (Cat. 957), CYG3 (Cat. 958), GS1 (Cat. 964), FZZ (Cat. 965) tombs, as well as in a tomb at Chenggou, Fuxin city, Liaoning province (Cat. 961), Tomb at Kangjiazhangzi, Jianping city, Liaoning province

(**Cat. 962**), and Tomb at Sidaowanzi township, Aohan Banner, Inner Mongolia (**Cat. 967**). The GGT (**Cat. 968**), GWYC, and LQW (**Cat. 959**, **Cat. 960**) kiln sites produced this variety of the ring-foot bowl.

- III. Shows an outcurved contour, a shallower belly than the previously described varieties, and a big ring-foot. Examples were unearthed from the BL1 (**Cat. 973**) and GZX (**Cat. 974**) tombs.
 - IV. Displays an outcurved contour, an even shallower belly than Type Ca III, and a small, straight ring-foot. An exemplar was detected in the BL3 tomb (**Cat. 976**).
- Cb. The overall shape is circular and foliated. According to its evolution, two varieties of Type Cb can be defined.
- I. Marked by an outcurved contour, a deep belly, and a large, straight ring-foot. An example was discovered in the DQTL3 tomb (**Cat. 981**).
 - II. Displays an outcurved silhouette, and a shallower belly and bigger straight ring-foot than Type Ca I. An example of this variety was recovered from the CGGZ tomb (**Cat. 982**).

Type D. Characterized by outcurved sides, a concave rim, and an overall simple and form. Owing to its evolution, two varieties of Type D can be distinguished.

- I. Exhibits a slightly incurved mouth rim, a heavily outcurved belly, and a flaring ring-foot. An example was located in the DSLT1 tomb (**Cat. 984**).
- II. Displays a strongly incurved mouth rim, a slightly outcurved belly, and a straight ring-foot. Samples of this variety were unearthed from the JFYZ (**Cat. 985**), XLZZ (**Cat. 987**), ZDB (**Cat. 988**), and BL3 (**Cat. 989**) tombs, as well as from a tomb at Xinlin village, Xianfeng township, Alike'erqin Banner, Inner Mongolia (**Cat. 986**), and a tomb at Laopogou, Linjiadi township, Aohan Banner, Inner Mongolia (**Cat. 990**). Exhibition pieces of this kind can be found in collections of the Liaoning Provincial Museum (**Cat. 992**, **Cat. 997**), the Palace Museum of Beijing (**Cat. 995**), the Chifeng Municipal Museum (**Cat. 998**), and the Aohan Banner Museum of Inner Mongolia (**Cat. 993**).

Type E. Defined by its heavily outcurved sides, slightly incurved neck, everted mouth rim, and big ring-foot. Examples of this type were unearthed from the DQYL3 (**Cat. 999**) and YLYZ (**Cat. 1000**) tombs.

3.16 THE DRAGON-HANDLED BOWL

The dragon-handled bowl, generally referred to as Longbingxi, Longbingwan (bowl with a dragon-shaped handle), or Kui in Chinese, is characterized by its bowl shape with a flat base, the straight rim, and the peculiar dragon-shaped loop-handle which connects the mouth with the belly. It prevailed mainly from the Late Liao period until the Jin and Yuan dynasties. Ceramic Liao dragon-handled bowls were located in numerous Late Liao tombs, such as ZWZ (1093) (**Cat. 1005**), ZSQ (1116) (**Cat. 1006**), ZSB (1115-1144) (**Cat. 1007**), and JSFJ (**Cat. 1008**). A similar brass example was recovered from XTM (MWG3) (d.1070) (**Cat. 1010**). A mural painting discovered in the ZSB tomb depicts two maidservants assisting their master at washing his hands and face (**Pl. 360**); one is holding a dragon-handle bowl in her left and a towel in her right hand, while the other offers a mirror with both her hands. The illustration proves the usage of the dragon-handled bowl for procedures of personal hygiene. The yellow-glazed dragon-handle bowl unearthed from the ZWZ tomb was discovered on a wood offering table and holding chestnuts, thus indicating its function in sacrificial rituals.

3.17 THE FLAT-BASE BOWL

A flat base is the eponymus trademark of this type of bowl. Due to variations in its form, two sub-types must be distinguished.

Type A. Marked by straight sides, a straight rim, and a slightly outcurved bottom.

Examples of this kind were unearthed from the HYM (**Cat. 1015**) and WDGM (**Cat. 1016**) tombs.

Type B. Features slightly outcurved sloping sides, a straight rim, and a flat base.

Samples were recovered from the ZSQ (**Cat. 1019**) tomb as well as from Tomb at Xiyongfeng village, Anci township, Langfang city, Hebei province (**Cat. 1020**).

3.18 THE STEP-FOOT BOWL

The form of this nomadic-style utensil is generally characterized by a high, flaring step ring-foot and outcurved sides. According to its evolution, three varieties of the Liao step-foot bowl can be distinguished.

I. Displays flaring sides, a straight mouth rim, and a relatively high step-foot.

Examples were unearthed from the SZG1 (**Cat. 1023**) and HLB1 (**Cat. 1024**) tombs.

II. Has a heavily outcurved contour, a slightly everted rim, and shallow belly. In comparison with its precursor, the step-foot is. A sample of this kind was discovered in the QCH tomb (**Cat. 1026**).

III. Exhibits an outcurved contour, an everted rim, a deep belly, and a very small and low step-foot. An example was found in the Liao Lizhou Old city site, Kazuo county, Liaoning province (**Cat. 1027**).

3.19 THE RING-FOOT DISH

The name-giving characteristic of this traditional Chinese utensil is its ring-foot. It was widely used in Liao territory by both Khitan and Han people and constitutes a large proportion of Liao ceramics, as evidenced by the great quantity of ring-foot dish shards found at major Liao kiln sites like LQW, GWYC and GGT. As indicated by those remains, ring-foot dishes were usually large in size and had a curved or angular contour, thus displaying familiar traits of traditional Chinese ceramics.

According to variations of its form, two types of the Liao ring-foot dish can be distinguished.

Type A. Marked by flaring sides, a straight rim, and low foot. Two sub-types must be classified owing to divergences of the overall shape.

Aa. The overall form is simple and round. Due to its evolution, three varieties of Type Aa must be classified.

I. Exhibits a strongly outcurved silhouette and a big ring-foot. Examples of this kind were discovered in the GZX (Cat. 1029), SJG1 (Cat. 1030), and GMZ (Cat. 1031) tombs.

II. Displays a slightly outcurved contour and a smaller ring-foot than its forerunner. Samples were recovered from the DPC (Cat. 1032), GSZ1 (Cat. 1033), GSZ2 (Cat. 1034), XLZZ1 (Cat. 1035, Cat. 1036, Cat. 1037), WLHD (Cat. 1040), YS3 (Cat. 1041), YMT8 (Cat. 1042), PJG3 (Cat. 1043), and HQY6 (Cat. 1044) tombs. Further exemplars were located in a tomb at Shuangsheng village, Longchang township, Balin Left Banner, Inner Mongolia (Cat. 1054). Type Aa II can also be observed in collections of the Liaoning Provincial Museum (Cat. 1059, Cat. 1065, Cat. 1066, Cat. 1068), the Inner Mongolia Autonomous Region Museum (Cat. 1050), the Tokyo National Museum (Cat. 1051), the Palace Museum in Beijing (Cat. 1047), the Jilin Provincial Museum (Cat. 1062, Cat. 1064), the Chifeng Municipal Museum (Cat. 1063), the Liaoning Tieling Qunzhong yishuguan (Cat. 1058, Cat. 1060, Cat. 1061), the Indianapolis Museum of Art (Cat. 1045), and the Liaoshangjing Museum (Cat. 1054).

III. With an angular silhouette and a comparatively smaller but higher ring-foot than Aa I and Aa II. Examples of this kind were found in a tomb at Xiyongfeng village, Anci township, Langfang city, Hebei province (Cat. 1067) and at the GGT kiln sites.

Ab. Characterized by an overall circular and foliated form and small ring-foot. According to its evolution, three varieties of Type Aa can be defined.

- I. Distinguished by a slightly outcurved contour, a five-lobed, foliated mouth rim, and a short ring-foot. Examples were located in the DQTL3 (**Cat. 1069**) and XJM (**Cat. 1070, Cat. 1071**) tombs.
- II. Defined by a heavily outcurved silhouette, a four- to twelve-lobed, foliated mouth rim, and a higher ring-foot than its precursor. Samples of this variety were recovered from the DXG1 (**Cat. 1075, Cat. 1076, Cat. 1078, Cat. 1079, Cat. 1080**) tomb and from the QZBT (**Cat. 1077**) pagoda.
- III. Shows an angular contour, a six- to sixteen-lobed, foliated mouth rim, a relatively shallow belly and a high ring-foot. Examples were unearthed from the PJG3 (**Cat. 1084**) and ZWZ (**Cat. 1081, Cat. 1082**) tombs.

Type B. Characterized by flaring sides, an everted rim, and a low foot. Owing to variations of the overall form, two sub-types must be distinguished.

- Ba. The overall shape is simple and round. As it runs through several stages of evolution, three varieties of Type Ba must be classified.
 - I. Marked by a slightly outcurved contour and a relatively big, short ring-foot. Examples of this variety were recovered from the SZG1 (**Cat. 1088**) and BTZM (**Cat. 1089**) tombs.
 - II. Distinguished by a strongly outcurved silhouette and a smaller and higher ring-foot than that of Type Ba I. Samples were discovered in the PJG3 (**Cat. 1090**) and HQY9 (**Cat. 1097**) tombs, as well as in a tomb at Zhaoduba, Chaoyang city, Liaoning province (**Cat. 1092**), a tomb at Chenggou, Fuxin city, Liaoning province (**Cat. 1093**), and Tomb at Xiyongfeng village, Anci district, Langfang city, Hebei province (**Cat. 1096**).
 - III. Displays an angular contour and a small, straight ring-foot. Examples were discovered in the TJYZ (**Cat. 1098**) and WFG (**Cat. 1099**) tombs.
- Bb. Recognizable by an overall circular and foliated form. According to its evolution, three varieties of Type Bb can be classified.
 - I. Has a slightly outcurved contour and a relatively large, high ring-foot. Examples were unearthed from the DQTL3 (**Cat. 1100**), HLB1 (**Cat. 1101**), TZM2 (**Cat. 1102**), and ZJY1 (**Cat. 1103**) tombs.
 - II. Marked by a strongly outcurved silhouette and a ring-foot bigger and higher than that of Type Bb I. Examples of this variety were located in the YMT7 (**Cat. 1104**) and HLDT2 (**Cat. 1105**) tombs.

- III. Defined by an angular contour, a comparatively shallow belly, and a short, small ring-foot. Samples were recovered from the MJ1 (**Cat. 1107**), ZWZ (**Cat. 1108**), and CDMM (**Cat. 1109**) tombs.

3.20 THE FLAT-BASE DISH

The signature feature from which the flat-base dish derives its name is its level footing. According to variances of the overall form of the flat-base dish, four types can be classified.

Type A. The overall form is circular, foliated, and flaring. It rests on a flat base, has a rim, and in some cases shows six- or eight-lobed sides. The foliated shape is reminiscent of many Tang gold and silver wares, so that this particular vessel form appears to be a derivation from a metallic prototype. Type A Liao dishes predominantly occur in three-colored ware decorated with molded designs, examples of which were unearthed from the FZZ (**Cat. 1110**), BL3 (**Cat. 1111**), and ZKM (1090 AD) tombs, as well as from a tomb at Zhangjiayingzi, Jianping city, Liaoning province (**Cat. 1113**), a tomb at Wulanba village, Haoertu township, Balin Left Banner, Inner Mongolia (**Cat. 1118**), and the GWYC kiln site (**Cat. 1116**) which is dated to the Late Liao period. Exemplary specimens are included in collections of the Liaoning Provincial Museum (**Cat. 1112**) and the Palace Museum in Beijing (**Cat. 1122**). A flower is molded on each of the exterior lobes of these examples, while a rosette is set against the dish's center on the background of a wave. A number of Type A white-glazed exemplars were discovered in the WJS1 (**Cat. 1125**), XYF1 (**Cat. 1126**), YS3 (**Cat. 1127**), ZWZ (**Cat. 1128**), GS1 (**Cat. 1129**), and ZGY (**Cat. 1131**) tombs, as well as at Pagoda Qiyinsi, Xianghe county, Hebei province.

Type B. Displays a square overall form with flaring sides, irregular edges, and a flat base. It occurs in both white porcelain ware and three-colored earthenware, and is generally decorated with molded floral designs. The three most popular motifs to be found on the Type B square dish are a peony flower with four leaves, a quatrefoil pattern, and a pair of butterflies set vis-à-vis. This rather unusual form of vessel has been suggested to be derived from wood or leather utensils used by the Khitan.⁴²⁶ However, its irregular edges and the sometimes beaded ornaments, like those adorning the white dish in **Cat. 1135**, are common on gold and silver ware instead, implying a metallic origin of the type. The porcelain exemplars of the square flat-base dish, which show strong affinities with Ding ware, were mostly unearthed from Liao Buddhist pagodas, such as Pagoda BZCT (1051AD) (**Cat. 1132**), CYBTTG

426 Liaoningsheng bowuguan 1961, p. 100.

(**Cat. 1133, Cat. 1135**), and CYBTDG (**Cat. 1134**). These places of worship are dated to the mid-11th century, suggesting that the finds may have functioned as utensils for Buddhist ceremonies. Fragments of a white porcelain square dish were found in the QHM2 (1057AD)(**Cat. 1136**) tomb and in a tomb at Hadatu village, Hadayingge township, Balin Left Banner, Inner Mongolia (**Cat. 1139**). Exhibits of Type B can be observed in collections of the Liaoning Provincial Museum, the Capital Museum in Beijing (**Cat. 1137**), the Buffalo Museum of Science (**Cat. 1142**), the Cleveland Museum of Art (**Cat. 1141**), the Art Institute of Chicago (**Cat. 1140**), and the Museum of Far Eastern Antiquities in Stockholm (**Cat. 1138**).

It was at the LQW kiln site in Beijing, where the discovery of a biscuit mould for the production of the Type B square dish and similar green-glazed earthenware dishes was made (**Cat. 1143, Cat. 1144, Cat. 1145**).

The majority of the three-colored examples of Type B were located Liao tombs of the Late period, such as the XXZ (1089 AD) (**Cat. 1146**), XLZZ1/2/4 (**Cat. 1148**), and XPJG (**Cat. 1147**) tombs. Collected pieces of this kind can be found at the Liaoning Provincial Museum (**Cat. 1153, Cat. 1154, Cat. 1157**), the Palace Museum in Beijing (**Cat. 1151**), and the Chifeng Municipal Museum (**Cat. 1155, Cat. 1156**). The most prevalent decoration among the three-colored specimens is a molded peony in full bloom. It is placed at the center of the interior bottom of the dish with more flowers and cloud patterns on all four sides, a small leaf in each corner, and vines along the rim. In order to achieve a three-color design, the pinkish clay of the body was commonly covered with white slip and subsequently embellished with patches of green and amber-yellow glazes. Archaeological evidence tends to imply that white porcelain Liao square dishes are slightly earlier than three-colored ones.

Type C. The overall shape is triangular with flaring sides and scalloped edges, resembling the silhouette of a butterfly. The interior is decorated with a molded butterfly which matches nicely the scalloped edges (**Cat. 1158**). As is the case with Type B, the eccentric form of Type C is regarded to be modeled after wooden utensils.⁴²⁷ However, the habit of translating a butterfly into the shape and the decorative motif of a vessel is known to have priorly appeared in the metal ware of the Tang dynasty, for instance on a silver box discovered at Dingmaoqiao township, Dantu city, Jiangsu province (**Cat. 1160**).⁴²⁸ Despite a difference between the types of these vessels, it appears that the box was shaped and decorated on the grounds of the same artistic idea as was the Liao triangular dish.

427 Zhongguo guisuanyan xuehui 1982, p. 322.

428 Dantuxian wenjiaojū & Zhenjiang bowuguan 1982, 15-27, fig. 35.

The Liao triangular dish occurs merely in white porcellaneous ware, and the only registered excavated examples are the four pieces discovered in a Late Liao tomb at Dawopu, Chifeng city, Inner Mongolia.⁴²⁹ As all these dishes bear a guan mark, characteristic of a group of white wares produced not later than the very early 11th century, it is likely that they were fabricated far earlier than square dishes. Noteably, a similar triangular dish was unearthed from a tomb of the Five Dynasties at Changsha, Hunan (**Cat. 1158**).⁴³⁰ The nature of its relationship to the Dawopu pieces, however, still awaits to be studied.

Type D. Marked by an octagonal overall form and flattened rims, this type of the flat-base dish can be found in a collection of the Liaoning Provincial Museum (**Cat. 1162**).

3.21 THE OBLONG-LOBED DISH

This peculiar type of dish is characterized by an oblong form with lobed sides, a lobed and flattened rim, and a flat base. It constitutes a direct copy of a metal ware. A number silver dishes is likely to represent the prototype imitated by Liao potters, such as the exemplars housed in the British Museum in London (**Cat. 1170**)⁴³¹, in the Zhenjiang Museum of Jiangsu province (**Cat. 1166**), in the Inner Mongolia Autonomous Region Museum (**Cat. 1173**), as well as examples unearthed from a tomb at Dingmaoqiao, Dantu, Jiangsu province (**Cat. 1167**), a tomb at Baiyintala, Keyouhou Banner, Inner Mongolia (**Cat. 1171**), and a site at Datong, Shanxi province (**Cat. 1169**). The silver dish discovered in a Liao cache at Paoziying, Balin Right Banner, Inner Mongolia, adds further archaeological support to the existence of a metallic origin for the ceramic dish (**Cat. 1172**).⁴³² The Paoziying exemplar displays a similar oblong-lobed form, if slightly simpler. More importantly, it is decorated with the same three rosettes on the interior as are later examples of ceramic dishes of this type. The oblong-lobed dish also appears in Liao mural paintings. In an illustration located in the GYY tomb (1020 AD), a Khitan

429 Zheng Long 1959, 47-48.

430 Hunansheng bowuguan 1966, 159-160.

431 The oblong-lobed silver dishes housed in the British Museum have formerly been regarded as Tang products, see Gyllensvard 1957; however, Margaret Medley proceeded to attach them to the Liao kingdom based on their similarity of form to examples of Liao ceramics, see Medley 1972.

432 Ba Youwen & Cheng Shun 1980, 45-51.

figure is depicted holding a vessel of said oblong-lobed form (**Cat. 1164**)⁴³³, and in the mural painting of Tomb at Qijia, an oblong dish is shown to be served as a saucer with two tee-cups standing on it (**Cat. 1165**). While there is no indication of the material of the painted vessel, its appearance nevertheless shows that the oblong-lobed dish, either in metal or ceramic ware, was already in use during the early 11th century.

All known examples of the oblong-lobed dish are pinkish earthenwares coated in three-color lead glazes and decorated with molded designs of peony sprays, lotus rosettes, swimming fish, etc. The GWYC kiln is known to have produced this type of vessel (**Cat. 1190**) and correspondingly both the polychrome lead-glazed oblong-lobed dish and the corresponding molded instrument were unearthed at the site. Other places of discovery of such three-colored dishes are invariably Liao tombs dated from the mid-11th century to the Late Liao period, namely the XLZZ1 (**Cat. 1174**), XLZZ4 (**Cat. 1184**), BL3 (**Cat. 1175**), PJG3 (**Cat. 1176**), YS1 (**Cat. 1186**), YS3 (**Cat. 1191**), XXZ (**Cat. 1183**), BTYZ (**Cat. 1177**) tombs, as well as a tomb at Xigou, Manihan township, Aohan Banner, Inner Mongolia (**Cat. 1197**). Accordingly, it may be assumed that the production of the oblong-lobed dish was adopted relatively late. Exemplars are contained in collections of the Liaoning Provincial Museum (**Cat. 1180, Cat. 1189, Cat. 1200, Cat. 1201**), the Chifeng Municipal Museum (**Cat. 1187, Cat. 1188**), the Palace Museum in Beijing (**Cat. 1196**), the Tokyo National Museum (**Cat. 1178, Cat. 1181**), at Ataka in Osaka (**Cat. 1179**), the Museum Yanato Bunkakan in Nara (**Cat. 1185**), the Idemitsu Museum in Tokyo (**Cat. 1194**). The SJ kiln is also said to have produced this type of dish in white porcellaneous ware without decorations.

3.22 THE INKSTONE AND BRUSH-WASHER COMBINATION

3.22.1 Introduction

The majority of Liao ceramic inkstones and brush-washers are assembled in a two-part construction, and most often occur in three-color lead-glazed earthenware decorated with molded designs. Nevertheless, several examples in white-glazed stoneware also exist. The general form represents a low, cylindrical or octagonal body with molded designs of eight panels on the vertical sides. The top-side serves as an inkstone and is decorated on the outer edge with molded designs of peonies and scrolls arranged around a centered, slanted ink pool. The high end of the ink pool is unglazed to allow the use of the exposed rough clay body for grinding ink. The underside of the vessel serves as a brush-washer, formed as a concave, shallow basin covered with plain lead glaze. This particular kind of the two-part constructed inkstone and brush-washer prevailed during the Late Liao period.

433 Zhu Zifang & Xu Ji 1983, 168-95.

3.22.2 Typological Analysis

Due to variances of its form, the two-part constructed inkstone and brush-washer can be divided into three types.

Type A. Has a round overall shape. Examples of this variety were discovered in many Liao tombs of the Late Liao period, such as the SFC (**Cat. 1204**) and BTYZ (**Cat. 1203**) tombs, or a tomb at Shifo township, Ningcheng city, Inner Mongolia (**Cat. 1210**). Some unfinished three-color-glazed pieces were found at the GWYC kiln site (**Cat. 1211**), and a white-glazed stoneware was located at GGT (**Pl. 115**), giving an indication as to the production areas of this type of vessel. Exemplary pieces are contained in collections of the Liaoning Provincial Museum, the Chifeng Municipal Museum (**Cat. 1212**), the Museum für Ostasiatische Kunst in Berlin (**Cat. 1206**), and the Tokyo National Museum (**Cat. 1207**). The low cylindrical combination with a slanted, cloud-shaped ink pool in the middle of the top side, which was unearthed at Shifo village, represents an extraordinary example of Liao lead-glazed ceramics in terms of the brilliant color of the glaze and the crisply molded designs. The ink pool is rendered as a yellow lotus pond set against a green background of waves. Surrounding the ink pool are auspicious motifs, such as butterflies, clouds, and peonies. Four panels adorned with dragon motifs alternate with columns of white flowers to decorate the sides of the inkstone. Bright green, brown, and transparent glazes are applied all over, with the exception of the high end of the ink pool, which was deliberately left unglazed so that the exposed clay body could be used for ink grinding. The opposite side of the concave, basin-formed brush-washer is glazed, allowing a conversion of the inkstone into a brush-washer by flipping it over. A similar white-glazed example has been discovered at DYZ3, but it is an exemplar of white porcellaneous quality and decorated with incised peonies (**Cat. 1202**).

Type B. Displays an octagonal overall shape. Examples were unearthed from the XTM (MWG3) (1070AD) (**Cat. 1214**) and XLZZ3 (**Cat. 1213**) tombs. Some unfinished pieces were discovered at the GWYC kiln site, indicating the area of production. The octagonal combination unearthed from XTM (MWG3) is similar to Type A, as the top side of the inkstone is also decorated with a lotus pond and floral motifs. On the eight vertical sides of the body, more flowers are molded in relief. The octagonal shape of the inkstone in addition to its yellow-glaze border is associated with a gilded-silver vessel which may have served as a model for Type B. The underside of the vessel functions as a separate, basin-shaped brush-washer which is coated in a plain yellow glaze. The the Marsuoka Art Museum in Tokyo houses a similar

white-glazed example which has been designated as a Ding ware. It is adorned with molded designs which include beaded ornaments, a decoration clearly indicating a metallic origin for this type of vessel (**Cat. 1217**).

Type C. An example of this drum-shaped inkstone was unearthed from the BTYZ tomb (**Cat. 1218**). The unglazed flat topside serves as the inkstone. The slightly curved belly is decorated in relief rivet designs and coated with yellow glaze. The inside of the vessel is hollow and there is no base attached to its bottom.

3.23 *THE OCARINA (HOLED WIND INSTRUMENT)*

3.23.1 Introduction

Referred to as Xun, Shao, or Di in Chinese, Liao ceramic ocarinas prevailed in the Late Liao period. They mainly occurred in lead-glazed earthenware and less frequently in coarse stoneware. The vessel was designed to accommodate the nomadic life of the Kithan. It was used for rounding up depasturing animals, or sometimes given to children as a toy.

3.23.2 Typological Analysis

Liao ceramics ocarinas occur in various shapes, according to which three different types can be classified.

Type A. Characterized by an oblate, spheroid shape. It has two openings on the top, a rhomboid mouth for winding, and a small, round hole through which the sound escapes. The Type A ocarina occurs mostly in three-color-glazed earthenware and is usually decorated with floral molded patterns which are arranged in horizontal zones. While various terms of identification - money-box, water-dropper, incense burner, flower stand, etc. - have been suggested to describe this unusual type, it remains a pottery ocarina, a simple musical instrument used in China since the Neolithic period. Examples were unearthed from many Late Liao tombs, such as the XTM (MWG3) (1070AD) (**Cat. 1221**) and XLZZ4 (**Cat. 1224**) tombs, a tomb at Yaojiagou, Jinchanggouliang township, Aohan Banner, Inner Mongolia (**Cat. 1222**), a tomb in the Songshan district, Chifeng city, Inner Mongolia (**Cat. 1223**), a tomb in the Yuanbao district, Chifeng city, Inner Mongolia (**Cat. 1225**), and a tomb at Linchang, Longchang township, Balin Left Banner, Inner Mongolia (**Cat. 1227**). It can be observed in collections of the Palace Museum in Beijing (**Cat. 1219**) and the Chifeng Municipal Museum (**Cat. 1220**). Some unfinished pieces were discovered in the GWYC kiln site (**Cat. 1226**), giving an indication of the corresponding area of production of the Type A ocarina.

Type B. Identifiable by various animal-head shapes, such as bulls, pigs, or lions. Wind openings can be discovered in the eyes and on the top of these heads. Examples of Type B *orcinas* were discovered at and collected from the Hancheng site of Liao Shangjing, Balin Left Banner, Inner Mongolia (**Cat. 1233**), and from the GWYC (**Cat. 1232,Cat. 1234,Cat. 1237,Cat. 1240**), LQW (**Cat. 1235**), and GGT (**Cat. 1236,Cat. 1238,Cat. 1239,Cat. 1241**) kiln sites, indicating the production areas of this kind of flute.

Type C. Marked by the shape of a squatting cat. There are openings in the eyes and on the back of the body. Examples of this kind were found in the Late Liao tombs of HPYZ1 (**Cat. 1242**) and a tomb in the Songshan district, Chifeng city, Inner Mongolia. Exemplary pieces are contained in a collection of the Liaoning Provincial Museum (**Cat. 1243,Cat. 1244**).

3.24 THE PILLOW

3.24.1 Introduction

Chinese ceramic pillows, which began to be produced and used during the Sui dynasty (581-618), showed an increasing quantity in the Tang dynasty (618-907) and were most prevalent in the Song, Jin, and Yuan dynasties from the 10th to the 14th century.

Those pillows discovered on Liao territory are of different materials, such as wood (JFYZ) or silver (CGGZ). Finds of Liao ceramic pillows were rare and apparently followed Chinese tradition.

3.24.2 Typological Analysis

According to variant forms, two types of the pillow can be classified.

Type A. Exhibits a trapezoid silhouette, a concave, rectangular top surface, and a relatively small but rectangular flat base. Examples of this variety were unearthed from several Liao tombs, for instance at Wulan village, Xinhui township, Aohan Banner, Inner Mongolia (**Cat. 1247**), at Banbu village, Baiyin'aobao township, Balin Left Banner, Inner Mongolia (**Cat. 1249**). Further finds were made at the ELC (**Cat. 1245**), HLC1 (**Cat. 1246**), and HTH1 (**Cat. 1250**) tombs.

Type B. Appears in the shape of a squatting tiger or lion. In some cases the surface of the back is concave. Examples were recovered from a Liao tomb at Guojia village, Xidayingzi township, Chaoyang city, Liaoning province (**Cat. 1255**), and a tomb in the Bayan'erdeng township, Balin Right Banner, Inner Mongolia (**Cat. 1253**).

Type C. Cognizable by an overall kidney-shape. Examples of this kind are contained in collections of the Shanxi Provincial Museum and the Aohan Banner Museum of Inner Mongolia (**Cat. 1256**).

Type D. Characterized by the overall form of a lotus leaf. The narrow stand is molded in the shape of four toads squatting outwards. An example was located at the LQW kiln site (**Cat. 1258**).

3.25 *THE BOX*

3.25.1 Introduction

In the Liao dynasty the box was employed as a container for tea, medicine, cosmetics, or incense powder. It frequently occurs as a gold or silver vessel, but also in Liao ceramics. A clay exemplar of a Liao box unearthed from the BTZM tomb (1081) still contained white cosmetic powder. A mural painting on the southwestern wall of the ZGY tomb (1117) depicts the scene of tea being served and contains the illustration of a set of nesting boxes sufficing as tea containers.

3.25.2 Typological Analysis

Liao ceramic boxes appear in various shapes, according to which two types can be classified.

Type A. This set of a single box with a cover displays an overall round shape which rests on a ring-foot. Owing to the evolution of its form, two varieties of Type A can be distinguished.

- I. Marked by a deep box body and a carinate belly. Examples of this kind were discovered in the HLB1 (**Cat. 1259**), BS1 (**Cat. 1260**), TYM2 (**Cat. 1261**), CGGZ (**Cat. 1262**), WZM (**Cat. 1264**), and YMT2 (**Cat. 1265**) tombs, as well as in Tomb at Yaojiagou, Jinchanggouliang township, Aohan Banner, Inner Mongolia (**Cat. 1266**), and Pagoda JGS (**Cat. 1263**). Exhibits are contained in collections of the Royal Ontario Museum in Toronto (**Cat. 1269**) and at Guan Baocong (**Cat. 1267, Cat. 1268**).
- II. Has a shallow box body with a curved belly. An example was located in the KL5 tomb (**Cat. 1270**).

Type B. Multiple boxes stacked in a set, referred to as nesting boxes. According to variant forms, Type B can be divided into three sub-types.

- Ba. Exhibits an overall oblong shape with four lobes. The straight sides are decorated with impressed designs. Echoing the shape of the box is a four-lobed opening on the

convex side of each box; on either side of these openings are diamond shapes and strings of pearls, all made in a style which mimics metal objects. Examples were located in the JFYZ tomb (**Cat. 1273**). It is contained in collections of the Chifeng Municipal Museum (**Cat. 1276**) and at Guan Baocong (**Cat. 1274**).

- Bb. The overall shape is eight-lobed and floral. Samples were found in the JFYZ tomb (**Cat. 1277**) and exhibits can be observed in a collection at Guan Baocong (**Cat. 1278**).
- Bc. Has an overall octagonal shape. Echoing the form of the box is an equally octagonal opening on the convex side of each box. Examples of this variety were unearthed from a tomb at Baitazi, Kazuo county, Liaoning province (**Cat. 1279**). The shape of the nesting boxes is derived from Sassanian metal ware. Sets of nesting boxes have their origin in China. The relic deposit (dated 874) underneath Famen Pagoda in Fufeng, Shaanxi province, yielded a luxurious set of five nesting boxes made of gilded silver (**Pl. 363**). Scholars have suggested that these boxes might have been the same boluozi listed on the accompanying inventory which was carved in stone. Since the boluozi were included in a sequence of vessels which was related to incense, it can be inferred that they were containers for precious incense and formed part of a larger set of vessels used for aroma burning.⁴³⁴ A small number of nesting boxes made of fine celadon was discovered in tombs of people of very high status, including the tomb of Queen Ma of the Wuyue kingdom (dated 939) and the tomb of Empress Li of the Song dynasty (dated 1000).⁴³⁵ All of these celadon nesting boxes were Yue ware from the northern Zhejiang province.

3.26 THE LAMP AND INCENSE BURNER

The lamp and incense burner is a vessel which appeared in small quantities and only during the Liao dynasty. According to its various forms, three types of it can be classified.

Type A. Characterized by a broad, flattened rim, straight sides, a carinate belly, and a stepped, carinate foot. Examples of this variety were located at the WZM (**Cat. 1280**) and LQW (**Cat. 1281**) kiln sites.

Type B. Has a narrower flattened rim than Type A and a hemispherical body. It bears circular relief designs on its curved sides. According to disparate foot forms, it can further be divided into two sub-types.

434 Niigata kenritsu kindai bijutsukan 1999, 170-71.

435 Hangzhou shi wenwu kaogu yanjiusuo & Lin'an xian wenwu guan 2000, 21, fig. 29.

- Ba. Displays a relatively small, hemispherical foot. Examples were recovered from the LQW kiln site (**Cat. 1284**).
- Bb. Rests on a comparatively higher, trumpet-shaped foot. Samples of this variety were also found at the LQW kiln site (**Cat. 1285**).

Type C. Marked by a silhouette in the shape of a horse or a dog which stands on the back of the burner and holds a bowl-shaped oil container. Samples of this variety were discovered at the GGT kiln site (**Cat. 1286, Cat. 1287, Cat. 1288, Cat. 1289**).

3.27 THE SCULPTURE

Large quantities of mini pinching sculptures which served as children's toys were unearthed from different Liao kiln sites. They occur in rough but bobbin-made stoneware or earthenware and are shaped to resemble animals and persons (**Cat. 1322**). The most popular form is an equestrian sculpture with a person on horseback, resembling an important aspect of the Khitan's nomadic life style (**Cat. 1291, Cat. 1297, Cat. 1301, Cat. 1303-Cat. 1311**).

Special attention should be paid to some miniature objects covered with a three-colored glaze (**Cat. 1323-Cat. 1335**). They prove that the custom of burying *mingqi* (mortuary models) with the dead, actually favoured by the Chinese, was also followed in Liao territory during the Late Liao period.

Furthermore, multiple Liao ceramic figures of Buddha were found, e.g. two white-glazed figures of Kasyapa (**Cat. 1338**) and Ananda (**Cat. 1337**) at Qianwulibuge village, Nailingao Sumu, Kulun Banner, Inner Mongolia. Some giant three-color lead-glazed earthenware Buddha figures also exist and are collected in both Liao temples and museums (**Cat. 1339-Cat. 1343**).

CHAPTER 4 DECORATION AND INSCRIPTION

According to the divergent appearances of Liao ceramics' adornments, a partition into glazed decoration and patterned decoration suggests itself.

4.1 GLAZED DECORATION

Apart from their practical protective function, glazes of multiple colors also have an aesthetic quality. As different ways of glazing give rise to diverse ornamental effects, each one must be set apart as an ambitious decorative technique instead of being neglected as merely another procedure in the process of ceramic production.

Glazed decorations of Liao ceramics fall into two groups, namely monochrome-glazed decorations and polychrome-glazed decorations.

4.1.1 Monochrome-glazed Decoration

As indicated by its name, monochrome-glazed decoration is the coating of a ceramic object with one single-color glaze, generally white, black, brown, teadust-green, green, or yellow glaze. In this group, as well as among all forms of glazed decorations of Liao ceramics, white-glazed wares occupy the dominant position (**Chart 6**).

4.1.1.1. White Glaze

Strictly speaking, Liao white glaze is a transparent varnish which is applied to a white body or on white slip and sustains the pallid hue of the ceramic's surface. From the beginning of its production in the Early Liao period until its end at the closing of the Liao dynasty, white-glazed ware constituted the largest quantity of all Liao ceramic produce and was widely used throughout all social classes (**Chart 6, Chart 7, Chart 8, Chart 9, Chart 11, Chart 12, Chart 13, Chart 14**). It mostly appears in the form of bowls, dishes, bag-shaped pilgrim flasks, lugged vases, long-neck vases, etc. The bodies of white-glazed ware can be divided into stoneware, porcelain, and a small group of earthenware. Their surfaces show varying degrees of whiteness and are often marked by tiny cracks. While most bodies plain and smooth, a few pieces are embellished with molded, carved, incised, or relief designs. Regarding aspects of white-glazed ware's forms, designs, and techniques, it is possible to observe the heavy influence of northern Chinese kilns of the Tang and Song dynasties, or more particularly of Xing, Ding, and Cizhou wares. White-glazed ceramics were used by both official and common people.

When applied to coarse stoneware, white glaze displays a grayish, yellowish whiteness (**Pl. 3, Pl. 4, Pl. 62, Pl. 80-Pl. 116**). A white slip layer between the body and the glaze functions to smoothen and beautify the coarse body and simultaneously prevents the glaze from appearing dry and dim. The thick, hard, and sandy bodies are fired at a high

temperature. The forming is not standardized and three to four spur-scars can often be found on the bottom of a vessel.

Porcelain white-glazed wares are particularly thin and of very fine quality (**PI. 5, PI. 59, PI. 176**). As the body itself is white and smooth, it is unnecessary to apply a white slip layer under the transparent glaze. Thus, the glaze and the body are completely conjoined and with high porcelain degree. Several tiny spur-scars can normally be discovered on the bottom of a vessel. In cases where the mouth-stand loading technique - influenced by Ding ware of China proper - is employed, an unglazed ring, referred to as Mangkou (i.e. Chinese for unglazed mouth), remains on the mouth of the bowl.

White-glazed ware, also counting a small amount of stoneware and a large quantity of porcelain ware, constitutes a high percentage of the total produce of the GWYC kiln site. Remnants of coarse stoneware, identifiable by their loose, impure bodies and rough forming technique, are scattered all over the tract (**PI. 3, PI. 4**). The color of the bodies usually is a grayish or yellowish white, but cases displaying a pinkish whiteness also occur. Under the transparent glaze, which displays either a yellowish or a greenish luster, a layer of white slip is applied. The most prominent forms of white-glazed stoneware are bowls, dishes, jars, and bottles. Occasionally, small handcrafted products like human figures, animal toys, chessman, ocarinas, etc. appear. In contrast to such coarse stonewares, porcelain wares (fine stoneware) have relatively dense bodies with little impurities and display a refined forming technique (**PI. 5**).

The white-glazed products of the SJY kiln are exclusively fine porcelain ware (**PI. 48**). Not only the quality of the body but also of the glaze is high, the production technique is also advanced. The purely white body supersedes the application of a layer of slip, and the transparent glaze coat is thin and even, shining gently and displaying a moist luster. The majority of these vessels are glazed from top to bottom. Cases in which the mouth-stand loading technique was applied are identifiable by the fact that while even the foot is coated with glaze, the mouth remains bare (mangkou). The most common vessel forms of SJY porcelain are bowls, dishes, bottles, vases, jars, spittoons, boxes, etc.

The white-glazed produce of the GGT kiln site comprises only coarse stoneware (**PI. 80-PI. 116**). Commonly, the bodies of these vessels are thick and loose. They show impurities and are of a grayish whiteness. A slip layer is applied to the body and the half-transparent glaze coat is of a grayish or yellowish color with little luster. Occasionally, the glaze layer is so thin that the stoneware has the appearance of biscuit. The most frequent forms in which the GGT white glaze ware occurs are bowls, dishes, vases, and small toys in the shape of human figures, dogs or horses, etc.

While both white-glazed stoneware and porcelain wares were fabricated at the LQW kiln site, it is the porcelain produce which is especially characteristic for its particularly dense and purely white body (**Pl. 175**). Furthermore, its vitreous texture is of a very high standard. The majority of these porcelain vessels have rather thin bodies and are fully glazed without an intermediate layer of slip. The transparent glaze is of a slightly grayish luster, if at times interspersed with tiny cracks. In comparison, the LQW stoneware has coarse, thick, and loose bodies (**Pl. 174**) which are only half-coated with a transparent, yellowish-white glaze. The sintering degree is lower, and in many cases several spur-scars remain on the bottom of a bowl or dish. Other vessel forms produced at the LQW kiln site are basins, bottles, and vases.

4.1.1.2 Black (Brown, Teadust-green) Glaze

Black-glazed ware also plays an important role in Liao ceramics. According to the bodies' clays, the predominant group of coarse stoneware and the smaller group of fine porcelain ware can be classified. Coarse stoneware is commonly characterized by a thick body and a heavy layer of glaze. Due to variations in the firing temperature, black glaze may appear in different hues from black (**Pl. 52**) over brown (**Pl. 190**) to teadust-green (**Pl. 63**). The surface of the glaze is usually uneven and blistered. Porcelain black-glazed wares mainly occur at the SJY kiln site. Their bodies are fine and white; the dark, greenish-black glaze is exquisite and gentle.

Among all the black-glazed produce from Liao ceramic kiln sites, the wares from SJY are of the highest quality (**Pl. 51, Pl. 53**). As mentioned above, SJY black-glazed wares are porcelains. Yet, while their bodies are dense and purely white, they remain slightly coarser than the white-glazed porcelains produced at the same site. The glaze is exquisite if sometimes unevenly applied. In places where it is dense (e.g. the foot's edge) the color is dark, whereas in parts where the coating is thinner (e.g. the mouth rim) it is light. The black glaze has a greenish touch, is lustrous, gentle, and calm, and occasionally interspersed with cracks. The most common forms of SJY black-glazed porcelains are vases, jars, bottles, etc.

In the case of the GWYC kiln site, black-glazed ceramics are exclusively stonewares (**Pl. 8, Pl. 9**). The yellowish- or grayish-white bodies are thick, coarse, and hard. The color of the glaze is relatively even and occurs in various in black, brown, and teadust-green tinges. The most frequent forms of the vessel are jars and chicken-leg vases.

Black-glazed wares from the BYGL kiln site are all stonewares, the glaze color of which shows black or teadust-green tinges (**Pl. 60, Pl. 61**). It is thickly applied, hardly lustrous, and has a blistered surface. The bodies are thick, hard, and coarse. Mostly, the vessels occur in the forms of either chicken-leg vases or big jars.

The black-glazed produce discovered at the GGT kiln site are solely stonewares with tinges of black or brown showing in the color of the glaze **Pl. 117-Pl. 170**). It forms a thick, almost dim layer interspersed with blisters. The white bodies are loose and have impurities. The most frequently occurring shapes of the GGT black-glazed wares are bowls, dishes, jars, chicken-leg vases, lamps, and some small toys of human figures, horses, or dogs, etc.

4.1.1.3 Yellow (Amber) Glaze

Yellow-glazed (amber-glazed) ceramics account for a high proportion of Liao ceramics. More often than not, these pieces are low-fired earthenware with a loose body and a high capacity of water absorption which shows in their pinkish or yellowish whiteness. An intermediate layer of white slip is applied directly on the body. Normally, the layer of yellow glaze ends several centimeters above the foot. It appears in different tones, mostly brownish-yellow or amber; pure yellow never occurs. Furthermore, it is thinly applied, lustrous, but interspersed with tiny cracks. A double-firing process can be attributed to this kind of earthenware, during which the body is first fired into biscuit, and following the application of slip and glaze is low-fired to finish the sintering. Nevertheless, the glaze is not strongly conjoined with the body and apt to flake off. It was at the GWYC and NSY kiln sites where yellow-glazed ceramics were produced. The most popular forms of these vessels were bowls, dishes, jars, bag-shaped pilgrim flasks, long-neck vases, phoenix-head vases, ewers, spittoons, saucers, etc.

4.1.1.4 Green Glaze

Green-glazed wares, second in quantity only to white-glazed products, represent a significant variety of Liao monochrome-glazed ceramics (**Chart 6**). They were especially favored by the middle and lower class people of Khitan (**Chart 13**). Just as yellow-glazed wares, they comprise almost exclusively low-fired earthenware. Their bodies are loose and have a high water absorption capacity, recognizable by their pinkish or yellowish whiteness. A white slip layer is applied to the body surface. The green glaze commonly expires several centimeters above the foot, and appears in different tones, such as dark-green, light-green, yellowish-green, etc. It is usually thinly applied, has a lustrous shine, but is also interspersed with tiny cracks and bubbles. The same double-firing process is applied to this kind of earthenware as the one described in the context of yellow-glazed decoration above: a bout of high-firing into biscuit followed by a phase of low-firing for the sintering of the glaze. Here, too, the conjunction of the body and the glaze is weak, so that the coating is given to flaking off. Green-glazed vessels most frequently occur in the shapes of bowls, dishes, jars, bag-shaped pilgrim flask bottles, long-neck vases, phoenix-head vases, ewers, spittoons, saucers, etc.

GWYC green-glazed earthenware is characterized by a fine but loosely textured body which has a pinkish-white color. The green glaze on high-grade products is lustrous and of a natural color.

The body texture of SJY green-glazed ware is the same as that of the kiln's white- and black-glazed products. The green varnish is opaque and rarely shows cracks on its surface.

At the LQW kiln site, green-glazed earthenwares also occur, but they only account for a small percentage of the entirety of its products. Nevertheless, the green glaze applied at LQW is outstanding in that it includes borax, an ingredient added a thousand years ahead of its more widespread usage in ceramic decoration worldwide.

4.1.2 Polychrome-glazed Decoration

Polychrome-glazed decoration denotes the coating of one and the same ceramic vessel with different colors. In Liao polychrome-glazed ceramics there are double-color- and three-color-glazed wares, the latter of which usually functioned as burial objects and account for a higher percentage of the overall produce than the former (**Chart 6**). The majority of polychromatically glazed wares belong to the group of low-fired pinkish earthenware.

4.1.2.1 Three-color Glazing

Tang potters specialized in the handling of three-color-glazed earthenware, experimenting with techniques of dotting, dripping, brushing, etc. as well as with wax-resistance, thus creating many different patterns and styles.

Liao three-color-glazed earthenware is the most florid variety of Liao ceramics and occupies a central position on the history of Chinese ceramics. It was produced at Liao kiln sites of the Late period, and while an influence of three-color-glazed Tang products can be observed, the Liao ware retains its originality. In contrast to the three-colored Tang ware's dense body, that of the Liao vessel is normally loose; its color is pinkish and it is fired at a low temperature. The glaze is composed of yellow, green, and white colors; blue, which appears in Tang exemplars, does not exist, and the Liao yellow is lighter. Most frequently, the Liao vessels take the shapes of bowls, dishes, oblong-lobed dishes, vases, ocarinas, inkstones, brush-washers, etc. While large animal figures like camels or horses, which often appear on Tang three-colored ceramics, do not occur, quite a few sizeable Buddha figures and animal-shaped architectural components can be found on Liao three-color-glazed earthenwares.

In summary, Liao three-color-glazed ceramics do not simply imitate the Tang precursors, but combine the Tang influence with new elements and progresses.

An example for such an innovative decoration is represented by the oblong-lobed dish in **Cat. 1184**. In this case, green color was used to illustrate water, yellow and white for the fish and the lotus flower. The glazes were perfunctorily applied so that the molded designs retain only rough shapes. A similar casual glazing technique was used for floral designs with yellow flowers and green leaves (**Cat. 1177**).

Coinciding with the Liao dynasty was the Song dynasty in China proper, and three-color-glazed ceramics were equally produced in its territory. However, the Song technique of surface decoration is very different the Liao method. Patterns are incised on the body and the cavities are subsequently filled with glaze, on the one hand creating an effect of clean edges of different colors, but on the other hand lacking in liveliness. In contrast, glazes on Liao specimens are applied freely on the molded designs of the ceramics surface, resulting in the blending of different glazes and the obscuring of their edges.

Only the Liao kiln sites of GWYC, NSY, and LQW produced three-color-glazed earthenware during the Late Liao period.

4.1.2.2 *Double-color Glazing*

Double-color-glazed decoration appears in several varieties: white-black (black glaze on a white glaze ground), white-brown (brown glaze on a white glaze ground), white-green (green glaze on a white glaze ground) (**Cat. 742, Cat. 741, Cat. 312, Cat. 313**), white-yellow (yellow glaze on a white glaze ground), and yellow-green (green glaze on a yellow glaze ground) (**Cat. 1144, Cat. 1145**). The bodies of such vessels are usually pinkish earthenware or stoneware, and the firing technique is the same as the one used for three-color-glazed earthenware. The methods of body surface decoration run the gamut from incising patterns and filling the cavities with glaze to dotting and painting decorations on the ground glaze.

White-black-glazed ceramics belong to the group of high-fired stonewares and were produced from Late Liao period onward. One type of white-black-glazed ceramics combined several methods of decoration, i.e. incising, carving, filling in glaze, etc., on one and the same vessel, predominantly on big jars, vases, etc. (**Cat. 611-Cat. 618, Cat. 570, Cat. 571**). This particular decorative process runs from the coating of the surface with white slip, over carving and incising floral designs on the body, to filling black iron glaze between the floral patterns, and finally to finishing the surface off with a layer of transparent glaze. In some cases the black glaze has a brownish tinge, an effect caused

by the firing atmosphere. This kind of white-black-glazed produce is influenced by the Cizhou ware of China proper. Another kind of white-black-glazed ceramics has black glaze dotted or painted on white ground (**Cat. 610, Cat. 672, Cat. 997, Cat. 472**). The GWYC and GGT kiln sites are known to have fabricated these products.

White-green-glazed ceramics are part of the group of low-fired earthenwares and were produced from the 11th century onward. The majority of the white-green-glazed wares are decorated adhering to the method of slipping, incising, and glazing, followed by applying green paint on the white ground. The shapes in which they mainly occur are long-neck vases (**Cat. 312, Cat. 313**), phoenix-head vases (**Cat. 369, Cat. 370**), basins (**Cat. 742, Cat. 741**), etc. Examples of white-green-glazed ceramics were discovered at the NSY kiln sites.

4.2 PATTERNED DECORATION

4.2.1 Motifs

4.2.1.1 *The Peony Spray*

The tree peony (*Paeonia arborea*), referred to as mudan in Chinese, is a widespread species in China. During the Song dynasty, it was a common decorative motif of Chinese potters.

One particular peony design repeatedly appears on Liao ceramics, namely the illustration of a spray of peonies enframed by serrated leaves. Two butterflies complete the natural scene. Typically, it is molded in low relief on oblong-lobed dishes and finished with glazes of yellow for the flower and green for the leaves (**Fig. 23-Fig. 25**).

Due to the fact that such oblong-lobed dishes were derived from a metal prototype, the question comes to mind if the peony design also occurs on the metal ware? While no parallels to the peony design have hitherto been found on metallic oblong-lobed dishes, the decorations of a silver ewer and a silver bowl discovered at Balin Left Banner, Inner Mongolia, seem to suggest an affirmative answer.⁴³⁶ The octagonal bodies of these two silver pieces are divided into different panels, each being adorned with a similar peony spray (**Fig. 26**). No butterflies were added, but the general arrangement of the flower and the leaves is very similar to the ceramic one.

Further analogous motifs can be observed on three-colored inkstones exhibited at the Tokyo National Museum and the Museum für Ostasiatische Kunst, Staatliche Museen Preussischer Kulturbesitz, Berlin. In these cases, both the arrangement of the flower and the leaves as well as the application of the glaze closely resemble decorations found on

436 Ba Youwen & Cheng Shun 1980, 45-51.

oblong-lobed dishes. However, the petals and leaves are described in greater detail on the inkstones. Another very distinctive feature is the inclusion of a lobed flower pot in the picture (**Fig. 27**), presumably an illustration of the way peonies were grown in Liao society. Similar pots planted with flowers can be observed in the paintings on a stone coffin in a tomb at Erbadi, Kalaqin Banner, Inner Mongolia (**Pl. 248**).⁴³⁷

It can be assumed that Liao peony spray designs were also molded on white-glazed, round-lobed dishes. Despite the fact that actual examples of such Liao dishes have not yet been discovered, evidence of their existence can be deduced from the a certain ceramic mold instrument discovered at the GWYC kiln site⁴³⁸ which is incised with a peony spray enclosed by two leaves (**Pl. 249**).

Apart from the method of molding, peony spray designs were also executed by incision. The procedure was commonly used on vases and bag-shaped pilgrim flasks of Type Ab and Type Ab . As the incised lines were inflicted with quick movements, the finished design was of a rather sketchy appearance. A typical example of an incised peony spray design can be observed on a green-glazed phoenix-head vase unearthed from a Liao tomb at Tuquan county, Xing'an League, Inner Mongolia (**Pl. 250**). The illustration of the flower is comparatively large, the two leaves are extending horizontally outwards, and details of both the petals and the leaves are only suggested. In other cases the stalk was omitted, for instance in the illustration adorning a vase exhibited at the Tokyo National Museum (**Pl. 251**). A rather simplified version of the design is displayed on the yellow-glazed long-neck vase in **Pl. 253** and the bottle in **Pl. 252**. The embellishment was apparently executed more quickly and with a reduced attention to the details of the petals. While comparable flower sprays with two horizontally springing leaves were also produced by carving, it must be noted that it was an uncommon procedure for this type of design (**Pl. 254, Pl. 255, Pl. 256**).

In contrast to peony spray designs on vases , the ones on bag-shaped pilgrim flasks are very often framed by U-shaped, raised ridges with two leaves pointing upwards, instead of horizontally outwards (**Pl. 257, Pl. 258**). The same type of motif can also be observed on bag-shaped pilgrim flasks bearing carved ridges (**Pl. 259**). The tradition of arranging two leaves pointing upwards from a peony spray was also retained on those flasks without ridges, with the exception that the leaves are frequently reduced both in size and detail (**Pl. 260**).

437 Xiang Chunsong 1984, pls. 10, 72.

438 Feng Yongqian 1984, 386-392.

Furthermore, peony spray incisions can be discovered on the interiors of flat vessels, for example on the white-glazed dishes discovered at the GZX and XJM tombs (**Fig. 28, Fig. 29**).⁴³⁹ Limited by the round decorative surface of the interior, two sprays form a roundel and each flower is accompanied by one leaf only. Another related design, containing three instead of two peonies, can be observed on a large, white-glazed dish from the GZX tomb, dated to 1026. Finally, an extremely sketchy example is represented on a large, white-glazed, lobed dish unearthed from the GYY tomb and dated to 1020 (**Fig. 30**).⁴⁴⁰ Its incised lines are limited in number but the general shape of the peony design, particularly its leaves, can still be identified.

It can be deduced from above examples as well as from the further occurrence of peony spray designs with two horizontal leaves on a number of tall vases, that the motif was very common among Liao decorations (**Fig. 31-Fig. 33, Pl. 261-Pl. 262**). A closely related and even more frequently applied structure has the same arrangement of the flower and the leaves but is usually smaller and lacks a stalk. It has been observed in stone carvings in Liao tombs.⁴⁴¹ In ceramics, the design predominantly appears on lead-glazed ware, particularly three-colored specimens. Molded in low relief, the flower and leaves of the motif are neatly arranged and given a sense of formality. When fashioned on circular dishes, the leaves are evenly spaced on one or two bands which encircle a central floral rosette. Examples of such cases were recovered from such Late Liao tombs as the XLZZ (**Fig. 31**).⁴⁴²

A comparable peony design can be found molded along the edge of the inkstone housed in the Museum für Ostasiatische Kunst, Staatliche Museen Preussischer Kulturbesitz, Berlin (**Fig. 32**). The sides of this vessel are also embellished with floral motifs, each framed by an oblong-lobed shape (**Fig. 33**). It is difficult to identify these patterns: on the one hand they appear to be a type of conventionalized floral design, but on the other hand the way that the flower and leaves are composed is rather reminiscent of the typical Liao style. The indicated conventionalized pattern was sometimes fashioned on three-colored square dishes (**Fig. 34**) Executed with four instead of only two leaves pointing outwards in four directions, it is a major motif.

439 Zhu Zifang & Xu Ji 1983, 168-95.

440 Zhu Zifang & Xu Ji 1983, 168-95.

441 Zhang Luzi 1958, 30-31.

442 Li Yiyou 1961, 44-49.

It is on the exterior of a brush-washer unearthed from the BTYZ tomb that a related symmetrically arranged floral design can be observed; yet, it is smaller and highly patterned, and both the flowers and the leaves are glazed in the same color (**Fig. 35**).⁴⁴³ Parallel decorations are molded on some white square dishes.

In contrast to such finely molded designs, those executed by incision are sketchy and relatively simple. On the heavy jars decorated in Cizhou style of **Pl. 263**, a narrow band of incised peony patterns is applied to the shoulder, running above and below the main motif of peony scrolls on a wide horizontal band around the body. These peony designs are very small and simply outlined.

4.2.1.2 *The Peony Scroll*

Liao peony scrolls were very often used to decorate large, Cizhou-style vessels, whereupon they were usually placed within a wide band encircling the upper section of the body. Several distinct types of this design can be distinguished.

The first type is an assemblage of two large peony flowers and a few pointed leaves. Each flower is composed of four or five large petals. Details of both the flowers and the leaves are achieved by incised lines. The design can be found on a dish-mouthed Liao vase discovered in Tomb YMT7 (**Fig. 36**).⁴⁴⁴ The floral scroll, depicted within the limits of a horizontal band, was executed by sgraffito technique and thus appears in white against a brown background. At least two more examples are known, one housed in the Idemitsu Museum of Art, Tokyo (**Pl. 265**), the other in the Metropolitan Museum of Art, New York (**Pl. 266**). Several Cizhou-type wares are known to be equally adorned with peony scrolls, however, the Song treatment is much stronger and the arrangement of the flowers and leaves is more complicated.⁴⁴⁵

A more crowded composition, caused by an increased number of flowers and leaves, characterizes the second type. However, the flowers are not dominating the arrangement. The details of the petals and the leaves are executed in combed lines, and a forceful movement distinguishes this type from many other Liao designs. It appears on Type Aa and Type Bd jars as well as on Type A Chinese-style vases (named meiping in Chinese). It is executed either in sgraffito (**Pl. 267-Pl. 273**), or by incision (**Pl. 274**), or by incision with the addition of a black glaze ground. Doubtlessly, the beehive-like flowers depicted on the meiping vase in **Pl. 277** is a stylization. Similarly

443 Feng Yongqian 1960, 15-24.

444 Liaoningsheng bowuguan et al. 1975, 26-36; Feng Yongqian 1975, 40-48.

445 Goto Shigeki ed. 1977, pl.109.

conventionalized flowers can be found on Cizhou-type wares of the 11th and the 12th centuries.⁴⁴⁶

The third type of the peony scroll design is rather rigid. The scroll proceeds in a straight horizontal line without any curvilinear movement, and the leaves simply point either upwards or downwards. This type is rare and only appears on a number of phoenix-head vases like (**Pl. 278, Pl. 279**). In these cases instances of sgraffito refined with an additional green glaze can be observed. Moreover, the cutting is crude and stiff and no additional detail was added to the petals and leaves.

The peony scroll decorating a white porcellaneous spouted ewer unearthed from the NLZ tomb belongs to a different tradition (**Pl. 280**).⁴⁴⁷ The design is carved in relief and details are achieved by incised lines, bringing to mind some early Song Ding wares by which it was probably influenced.⁴⁴⁸ In this case, the addition of incised butterflies, which also occurs on three-colored oblong-lobed dishes, is certainly the representation of a special interest in Liao ceramics.

The most exquisitely constructed peony scroll designs are those molded in relief. In such cases, the scroll is rhythmically curved and flowers, fringed by leaves, extend from it at regular intervals. Parallely can be found on stone engravings and wall paintings in Liao tombs (**Fig. 37, Fig. 38**).⁴⁴⁹ The earliest example of the pattern on ceramics so far discovered is the decoration of a three-colored inkstone which was unearthed from the SFC tomb and dated to 1066 (**Pl. 281**).⁴⁵⁰ However, the design was actually more commonly used to embellish the interior walls of lead-glazed bowls, such as the yellow-glazed bowls exhibited in the Tokyo National Museum (**Cat. 844**) and the green-glazed one discovered in the JFYZ tomb (**Cat. 895**). It also occasionally appears on three-colored glaze (**Cat. 941**) and white glaze (**Fig. 40**) wares.⁴⁵¹

4.2.1.3 *The Herbaceous Peony*

446 Goto Shigeki ed. 1977, pl.120.

447 Liaoyangshi wenwu guanlisuo 1977, 90-91.

448 See, for example, the floral design carved in relief on the kundika discovered in the foundations of a pagoda at Dingxian, Hebei. See Dingxian bowuguan 1972, 39-51, pl. 6:1.

449 See Deng Baoxue 1983, 30-38, fig. 15; Xiang Chunsong 1984, pls. 10, 72.

450 Li Wenxin 1958, 10-22.

451 Xiang Chunsong 1979, 330-34.

Being a common floral species in Northeastern China, it appears natural that the herbaceous peony (*Paeonia albiflora*), or shaoyao in Chinese, was used as a decorative motif for Liao ceramics. It mainly adorns white-green-glazed ware, particularly Type B basins (**Pl. 282, Pl. 283**) and Type A long-neck vases etc. (**Pl. 284, Pl. 285**). The design is usually composed of herbaceous peony rosettes and several acuminate leaves. The application technique of quick incisions gives it a simple and sketchy appearance. Since the vases and basins on which the herbaceous peony design occurs generally belong to the group white-green-glazed earthenwares, it may be deduced that it must have been popular during the 11th century.

4.2.1.4 *Overlapping Lotus Petals*

Predominantly popular during the late 10th and the 11th centuries was a type of Liao lotus design which consists of two or three layers of overlapping lotus petals with upturned tips (**Fig. 41 -Fig. 47**). The petals are carved in relief and mostly applied to the lower part of a vessel.

It is a very common design on early Song Ding ware and is known to have been affected by the decorations of Yue ware which was produced in Zhejiang during the Five Dynasties Period.⁴⁵² Considering that all major Liao kilns were heavily influenced by Ding techniques, it is not surprising that Ding designs should recur on Liao wares. Examples of such imitations were discovered among remains at Hebei, Liaoning, as well as in Inner Mongolia (**Fig. 50-Fig. 52**).⁴⁵³ However, identifications should be exercised with caution as it is always possible that some of these discoveries are not Liao but actual original Ding products, e.g. the ewer found in the SQ1 tomb.⁴⁵⁴ A Liao example is best represented by the dish-mouthed ewer located in the GYY tomb, which is based on a Chinese form but has been modified to match Liao taste by slenderizing the neck and transforming the mouth into a dish form (**Fig. 53**).⁴⁵⁵

A representation of a later stage of development of this overlapping lotus petal design on Liao ceramics can be observed in the decoration of the white-glazed dish-mouthed ewer in **Fig. 54** Again, three layers of lotus petals decorate the lower body; yet, the

452 See Shanghai renmin meishu chubanshe ed. 1981, 154-179.

453 Su Tianjun 1964, 49-53; Liaoningsheng bowuguan et al. 1975, 26-36; Xu Yulin 1977, 44-51; Pan Xingrong 1965, 374-76; Xiang Chunsong 1982, 56-63; Zhu Zifang & Xu Ji 1983, 168-95.

454 Xu Yulin 1977, 44-51.

455 Zhu Zifang & Xu Ji 1983, 168-95.

execution is simplified, and achieved by casually incised lines. As a result the delicacy and sculptural effect of Ding origin is completely lost.

Overlapping lotus petals also appear on Liao vessels which are decorated in a Cizhou style. The meiping vases in **Pl. 290** and **Pl. 291**, for instance, bear a band of incised lotus petals below the main zone of peony scrolls. The engraved lines were freely and quickly managed, but illogically intercrossed, producing a style which is very different from the delicate Ding type.

4.2.1.5 *The Lotus Rosette and Related Ornaments*

Another lotus design frequently appearing on Liao ceramics takes the form of a rosette. The bird's eye view of the flower reveals a star-like pattern. It is an embellishment which also appears on both gold and silver wares and on ceramics of the Tang dynasty (**Fig. 56, Fig. 57**). Continuing the Tang tradition, Liao artisans showed an interest not only in applying lotus rosettes on ceramics, but also on wall paintings and steles in tombs (**Fig. 58, Fig. 59**).⁴⁵⁶ In regard of ceramics, the earliest example of the rosette design that has been excavated to date appears on the green-glazed basin unearthed from the QCH tomb and dated to an approximate period from the late 10th to the early 11th century (**Fig. 60**).⁴⁵⁷ A lotus rosette is painted on the interior flat surface and the lotus seed-pod is also clearly indicated. The dots encircling the lotus rosette is reminiscent of the beaded ornaments adorning many Tang gold and silver wares; hence, it seems likely that the entire lotus rosette is a derivation from metal ware designs. Lastly, lotus rosette designs can also be observed on some Late Liao ceramic basins, for instance on the three-colored basins unearthed from the ZSB and ZWZ tombs, (**Fig. 61, Pl. 291**).

As a matter of fact, lotus rosettes executed in a painting technique, such as the QCH example, are quite rare among Liao ceramics. In most cases, they were molded on lead-glazed wares of the later part of the Liao dynasty. On oblong-lobed dishes, the design appears in two different ways: either accompanied by two other lotus rosettes set against the background of a wave (**Fig. 62**), or surrounded by several swimming fish against a wave background (**Fig. 63, Fig. 64**). The metallic origin of the Liao lotus rosette is more evident in the first example, as it displays that kind of bead outline which is also a characteristic of gold and silver ornaments (**Fig. 65**). Even more importantly, the side-by-side arrangement of three rosettes resembles the kind of alignment which appears on a oblong-lobed silver dish unearthed at Balin Left Banner, Inner Mongolia

456 Yan Wanzhang 1957, 69-82; Hebeisheng wenwu guanlichu et al. 1975, 31-39, pl.1,

457 Jin Fengyi 1980, 44-51.

(**Fig. 66**).⁴⁵⁸ Despite the fact that the silver dish from Balin Left Banner shows a double-fish motif at its center instead of a lotus rosette, and that it lacks a background of wave patterns, the other two lotus rosettes are obviously close to those on Liao ceramics.

When appearing on circular or on round lobed dishes, lotus rosettes are frequently molded at the center of the interior, either against a background of waves or surrounded by other floral designs (**Fig. 67**). A relatively rare occurrence are the dishes in **Fig. 68** and **Fig. 69**, which are decorated with extremely large lotus rosettes occupying the entire interior. A type of rosette with slightly S-curved petals may attribute to the same group. It is molded into the center of the interior of lead-glazed bowls and dishes, and surrounded by other symmetrically arranged designs (**Fig. 70**, **Fig. 71**). Liao rosettes of this type were commonly identified to be chrysanthemums by the Chinese, but Jan Wirgin suggested that they actually resemble conventionalized lotuses.⁴⁵⁹ He based his classification on a transitional form of the lotus rosette decorating the cover of a lead-glazed box in his own collection. It still contains the clear depiction of a lotus-pot at its center (**Fig. 72**). The rosette molded on the three-colored dish in **Fig. 73**, however, is centered on a lotus-like flower. It seems possible that the S-curved petals actually resemble the lotus leaves and the slightly S-curved lines represent leaf veins. A good piece of reference is a silver cover in the form of a lotus leaf which was unearthed at Dantu, Jiangsu.⁴⁶⁰

Sometimes, incisions of these lightly S-curved petals encircle the shoulders of long-neck and phoenix-head vases, or they are carved upon the mouth rim of some jars and covers (**Pl. 292**, **Pl. 293**, **Fig. 75**, **Fig. 76**). From a bird's eye view they also appear in the form of a rosette. Parallel arrangements can easily be found on contemporary Song ceramics, particularly on Cizhou-type wares.⁴⁶¹

4.2.1.6 *Scrolling Vines and Other Floral Ornaments*

One of the most distinctive Liao decorative motifs is the scrolling vine. It occurs incised on Type B bag-shaped pilgrim flasks of Group 1 (**Fig. 77** - **Fig. 82**) and in several variations. The simplest form resembles closely to the vine of plant (**Fig. 77**, **Fig. 78**), while more complicated ones are so schematized that it is difficult to identify the plants

458 Ba Youwen & Cheng Shun 1980, 45-51.

459 Wirgin 1960, 25-46.

460 Dantuxian wenjiaoju & Zhenjiang bowuguan 1982, 15-27.

461 Goto Shigeki ed. 1976, pls. 116, 117.

depicted therein (**Fig. 79, Fig. 80, Fig. 81**). Generally speaking, the Liao scrolling vine design consists of a limited number of symmetrically arranged scrolling lines. Similar in style but different in motif are those designs found on the bag-shaped pilgrim flask in the Avery Brundage Collection, Asian Art museum of San Francisco (**Pl. 295**). While they were executed with the same simple incision, the floral structures can easily be identified as leaves.

An entirely different type of a leaf scroll pattern is molded on the mouth rims of oblong-lobed dishes (**Fig. 83 -Fig. 87**). It was derived from the border scroll patterns of metallic prototypes. Parallel structures can be found on stone engravings and painted decorations in Liao tombs, but these exemplars are frequently regarded as cloud scrolls instead (**Fig. 94**).⁴⁶²

4.2.1.7 *Plantain Leaves*

Plantain leaves designs are best exemplified by the decorations on the ewers and bowls discovered in the ZKY (**Fig. 102**), YMT2 (**Fig. 96**), KJYZ2 (**Fig. 95**), MTYZ1 (**Fig. 97**), and Yaojiagou (**Fig. 100**) tombs.⁴⁶³ The leaves in those patterns are finely carved in the mode of an early Ding style. It is a kind of design which also appears on the interior of a white-glazed bowl unearthed from a Late Liao tomb at HQYZ6. However, in this case it was executed by molding instead of by carving (**Fig. 103**).⁴⁶⁴ The LQW kiln sites produced white-glazed jars decorated with a carved plantain leaves design (**Fig. 98, Fig. 99, Fig. 101**). According to the information gained from objects excavated from tombs and kiln sites, plantain leaves designs on Liao ceramics date to the 11th century.

4.2.1.8 *The Stippling Plum Blossom*

Stippling plum blossom designs were extensively applied on the Song dynasty's Cizhou wares in China proper. Since Liao ceramics were influenced by Cizhou ware, the design was adopted into the range of their decorations from the Late Liao period onward. It occurred on black- (brown-) painted white stonewares, and mainly on vessel forms prevailing during the 12th century like jars (**Pl. 297, Pl. 298**), bowls (**Pl. 299**), etc.

4.2.1.9 *The Butterfly*

The most distinct butterfly design occurs on Liao square dishes **Fig. 107, Fig. 108**), where it is the only decorative motif and nicely matches the scalloped edges. Based on

462 Yan Wanzhang 1957, 69-82; Xiang Chunsong 1984, pl. 5.

463 Deng Baoxue et al. 1983, 30-38, fig. 15.

464 Lu Sixian & Du Chengwu 1983, 1-8, fig.20.

evidence, such as the gilt silver box unearthed from Dantu, Jiangsu (**Pl. 300**)⁴⁶⁵, both Liao dishes and said type of butterfly decoration can be related to gold and silver wares. The surface of a Liao amber box recovered from the Xiaonuri tomb was also adorned with a butterfly design (**Fig. 109**). Notably, it is rather uncommon in Chinese ceramics to place a butterfly motif in such a dominant position. Comparable pieces can be observed among Yue ware dishes of the Five Dynasties period and early Song Ding ware. However, in these cases the design consists of two butterflies facing one another and was executed by incision rather than by molding (**Fig. 110, Fig. 111**).⁴⁶⁶

On Liao wares other than triangular and square dishes, butterflies are often placed in a subordinate position above a peony scroll or spray (**Fig. 114-Fig. 116, Fig. 117**). The subject of flower-and-butterfly is common in Liao art and can also be found in wall paintings.⁴⁶⁷ A ceramic example of the motif was unearthed from the NLZ tomb (**Pl. 301**). Yet, it is rather sketchy, displaying small butterflies incised above a peony scroll which in turn is carved in relief on a white porcellaneous ewer.⁴⁶⁸ Applied more frequently are rigid representations executed by molding. Examples of this kind can be observed on oblong-lobed dishes, where they are placed above a peony spray, giving rise to a relatively natural representational scene (**Fig. 114-Fig. 116**). Many others, however, are symmetrically arranged and alternate with floral designs; such examples occur on bowls (**Fig. 112, Fig. 113**), ewers (**Pl. 303**), or on ocarinas (**Fig. 117**).

Another very distinctive type of the butterfly design can be found on a white porcellaneous ewer unearthed from HQYZ6 tomb (**Pl. 302**).⁴⁶⁹ In this particular case, three pieces of molded ornaments in the shape of butterflies are attached to the three strands of the handle, giving the ewer a great sculptural effect. It echoes the triangular dish which is butterfly-shaped and adorned with a molded butterfly.

4.2.1.10 Fish

Liao fish motifs generally appear on three-colored oblong-lobed dishes. They are often fashioned to form a composition of several fish swimming around a central lotus rosette which is set against a wave background (**Fig. 118**). Executed by aid of a molding

465 Dantuxian wenjiaoju & Zhenjiang bowuguan 1982, 15-27.

466 Feng Xianming 1973, 20-29.

467 Xiang Chunsong 1984, pls. 3, 69.

468 Liaoyangshi wenwu guanlisuo 1977, 90-91.

469 Lu Sixian & Du Chengwu 1983, 1-8, fig.20.

technique and covered by casually applied glazes, the fish motifs only occur in a rough shape. Like other decorations appearing on oblong-lobed dishes, the design of swimming can also be traced back to a metallic origin. The Tang gilt-silver oblong-lobed dish discovered at Dantu, Jiangsu, for instance, is also adorned with four fish swimming around a central point in front of a background of radiating lines which may represent the veins of a lotus leaf (**Pl. 304**).⁴⁷⁰ It may have been the prototype for a Liao pattern: despite the fact that the Liao composition is slightly less organized, the general arrangement was retained.

Just like the butterfly motif, a Liao fish design may also appear as a molded ornament on a vessel's handle. A spouted ewer discovered in the HQYZ6 tomb displays two such molded fish in addition to an equally molded triangular floral ornament attached to the three strands of its handle (**Fig. 120**).⁴⁷¹

4.2.1.11 *The Dragon-fish*

It has been suggested that the dragon-fish motif is not traditionally Chinese but rather originates from the "makara", an Indian legendary figure, namely a water sprite regarded as the origin of life (**Fig. 121**).⁴⁷² As evidenced by the decoration of a stone coffin in the tomb of Li He at Sanyuanxian, Shaanxi, dated to 583, the "makara" began to be used as an art motif in China no later than the Sui dynasty (**Fig. 122, Fig. 123**).⁴⁷³ During the Tang dynasty, the motif was applied predominantly on gold and silver ware. At that point in time it had also been modified to represent more of a Chinese treatment, a change obvious in the combination of a Chinese type of dragon and an ordinary fish (**Fig. 124, Fig. 125**).⁴⁷⁴

The idea of using the dragon-fish subject on Liao ceramics is likely to have directly resulted from the influence of Tang metal ware, pieces of which haven been unearthed in Liao territory. The overall appearance and U-shaped body of these finds are consistent with other Tang metal wares. The Tang silver dish unearthed at Kalaqin Banner, Inner Mongolia, was decorated with two dragon-fish chasing flaming pearls (**Fig.**

470 Dantuxian wenjiaoju & Zhenjiang bowuguan 1982, 15-27.

471 Lu Sixian & Du Chengwu 1983, 1-8, fig.20.

472 Cen Rui, 1983, 78-80, 85.

473 Shaanxisheng wenwu guanli weiyuanhui 1966, 27-42.

474 Lu Jianguo 1980, 96; He Lin et al. 1983, 14; Zeng Yu 1984, 33-36; Dantuxian wenjiaoju & Zhenjiang bowuguan 1982, 15-27, fig.35.

126).⁴⁷⁵ The same motif can be observed on a gilt bronze plaque discovered in the SQ1 tomb (**Fig. 127**).⁴⁷⁶ In Liao ceramics, the two-dimensional motif is advanced into a three-dimensional sculptural vessel (**Pl. 308-Pl. 312**). While the U-shaped posture is retained, natural subjects like the lotus leaf and vines were added to the design for both practical and ornamental purposes.

Three examples of ceramic vessels in the shape of a dragon-fish have been recovered from Liao territory to date. The first exemplar was discovered in the SQ1 tomb, the place in which the gilt bronze plaque in **Fig. 127** was found (**Pl. 307**).⁴⁷⁷ It is a green ware of fine porcellaneous quality. The second specimen, a piece of white ware, was excavated from the KL5 tomb.⁴⁷⁸ Both exemplars have a U-shaped body similar to the example in **Pl. 308** and **Fig. 128**; however, the opening of the dragon mouth is much wider and as such compares to a dragon-form white ware in **Pl. 309**. It is important to note that the first two examples were probably not produced at Liao kilns: the SQ1 piece has been regarded as a Northern Song green ware and the KL5 vessel is reported to be Song Ding ware. Nevertheless, they still reflect a Liao interest in the dragon-fish subject, seeing as they are likely to have been produced in Chinese kilns and transported to the Liao area in order to satisfy the local demand. The third example is a locally made (GWYC Kiln), three-colored earthenware found at Ningcheng, Inner Mongolia (**Pl. 310, Fig. 129**).⁴⁷⁹ It differs from the other two exemplars in having a tall body instead of a horizontally elongated form. The mouth and handle are situated on the fish tail and the rear part of the vessel, and it rests on a stand of two elaborate layers of overlapping lotus petals. However, its U-shaped body as well as the plant-form mouth rim and handle are identical to those of the white ware in **Fig. 128**

4.2.1.12 *The Dragon and the Phoenix*

As evidenced by several wall and coffin paintings located in Liao tombs, the common traditional Chinese decorative motifs of the dragon and the phoenix were also used by Liao artisans.⁴⁸⁰ However, the amount of excavated Liao ceramics decorated with these

475 Kalaqinqi wenhuaguan 1977, 327-334.

476 Xu Yulin 1977, 44-51.

477 Xu Yulin 1977, 44-51.

478 Zhelimumeng bowuguan et al. 1982, 35-46.

479 Bai Junpo 1984, 91.

480 See, for example, Xiang Chunsong 1984, pls. 4, 17, 59, 61, 63.

subjects remains limited. A number of shards collected the SJY kiln site at Lindong, for instance, bore stiffly carved illustrations of dragons on the glaze⁴⁸¹, and fragments from the GWYC kiln were decorated with molded phoenixes and other designs (**Fig. 130**).⁴⁸² Furthermore, a large bowl incised with a roundel of phoenixes on the interior was discovered in the GYY tomb (**Fig. 131**).⁴⁸³ It can be counted into the repertory of Liao wares on account of its relatively inferior quality. An analogous incised phoenix roundel can be found on a Guan-marked, lobed bowl unearthed from the YMT7 tomb (**Fig. 132**).⁴⁸⁴ While the bowl is regarded to be a Ding ware, its decoration may represent the type of model followed by Liao potters. Another occurrence of the dragon and the phoenix motif - in this case applied in relief - appears on a very rare green-glazed bag-shaped pilgrim flask detected in a tomb at Beijing.⁴⁸⁵ The particular illustration of the dragon on this ewer, shown to rise from a lotus pond, is very similar to the design found on the gilded-silver inkstone case from the YLYZ tomb (dated 942) (**Cat. 93**). Moreover, it resembles an ornament applied to a piece of kesi silk tapestry - approximately two meters long - which was used to cover the corpse in the YMT7 tomb. In addition, lotus leaves depicted on the shoulder of the Beijing earthenware ewer are parallel to both the structures on the rims of the silver cups unearthed at You'ai village, Balin Right Banner (**Cat. 92**) and on the foot of the gold cup from the YLYZ tomb (**Cat. 83**). The connotation attached to the dragon rising from a lotus pond remains undefined; yet, the flaming pearl - a Buddhist symbol of wisdom - atop the lotus flowers on the ewer suggests a possible Buddhist connection.

4.2.1.13 The Monkey

Occasionally, one or two monkey figures were modeled to be seated astride on the carrying tabs of bag-shaped pilgrim flasks of Type B (**Pl. 317**), Type B (**Fig. 134**) and type B (**Pl. 318, Pl. 319**) of Group 2. Examples of this particular decoration can be observed on the bag-shaped pilgrim flasks unearthed from the tombs YMT7 (**Pl. 317**), AXZ (**Fig. 134**), and QCH (**Pl. 318**), etc. Small, squatting monkey sculptures were located at the LQW kiln site (**Fig. 136**).

4.2.1.14 The Human Figure

481 Li Wenxin 1958, 97-107.

482 Jia Zhoujie 1973, 241-43.

483 Zhu Zifang & Xu Ji 1983, 168-95.

484 Feng Yongqian 1975, 40-48.

485 Zhao Zhihou 1982, 43, fig. 2.

Two main motifs of human figures exist in Liao ceramics; children on the one hand, and a human taming an animal on the other hand.

The children motif can be found on the bag-shaped pilgrim flask unearthed from the GYY tomb (**Fig. 137**). The crawling, child-like figures are applied in relief and combined with incised scrolling vines to decorate the body's surface. The interior side of a white-glazed dish unearthed from HQY9 is decorated with the illustration of a scene of six children who are playing, hunting, and fishing together. A green-glazed bowl unearthed at Songshan district, Chifeng city, Inner Mongolia, is adorned with a scene of two children playing in the water. The LQW kiln site ever produced white-glazed pillows decorated with children and peony design.

A design depicting a human taming a dog is molded in relief on each of the eight side panels of a three-color-glazed inkstone unearthed from the tomb at Shaoguoyingzi, Jianping city, Liaoning province. Analogously, a design of a human taming a lion is molded in relief on each of the eight side panels of the three-color-glazed brush-washer unearthed from the XLZZ3 tomb (**Pl. 320**).

Also, a multitude of kneaded human-figure toys were recovered from different Liao kiln sites (**Pl. 322-Pl. 331**).

4.2.1.15 Others

The firing ball, one of the seven treasures of Buddhism, was also applied in relief on Liao ceramics, for instance on the green-glazed bag-shaped pilgrim flasks unearthed from the SQ1 (**Fig. 138**) and QCH (**Fig. 139**) tombs. This particular Liao design can be dated to the early 11th century.

Whirling floral, sun floral, and net floral designs can be observed on a number of basins (**Fig. 140-Fig. 144**).

Many bag-shaped pilgrim flasks retain the pouch from of the original leather bag. Furthermore, the raised ridges on their bodies are modeled upon the seams and the stitching of the leather prototype (**Cat. 105-Cat. 135, Cat. 95-Cat. 103, Cat. 1-Cat. 10**).

4.2.2 Layout

The entire diversity of Liao ceramics' glaze and body decorations is merged on Liao three-color-glazed earthenware, making it the most special variety. In the following section the layout of three-color earthenware designs will be discussed.

Principally, the decorative style of Liao three-color-glazed earthenware uses three colored glazes (white, yellow, and green) to decorate the body (or the white slip layer)

and its molded designs. Adhering to a number of regulations, different ceramic shapes are decorated with different patterns which follow relatively fixed layouts.

Four types of layouts can be distinguished among the decorations of three-color-glazed oblong-lobed dishes.

Type A. The main designs of this layout constitute a scene of five small, white- or yellow-glazed fishes surrounding a white-glazed lotus rosette. They are set against the green-glazed background of a waterwave. The interior vertical walls of the dish are white-glazed. The marginal ornamental band is composed of green-glazed, successively scrolling vines. **(Fig. 145)**

Type B. The principal designs of Type B are a yellow-glazed peony flower with green-glazed leaves set against a white-glazed background, and two yellow or green-glazed butterflies (or bees) flying around the peony spray. The interior vertical walls of the dish are yellow-glazed. The marginal ornamental band is composed of green-glazed, successively scrolling vines. **(Fig. 146)**

Type C. In this case, the major designs are three aligned white-yellow-glazed lotus rosettes, and four smaller, green-glazed flowers, which merge with the green-glazed background and are symmetrically arranged to enclose the center rosettes. The interior vertical walls of the dish are white-glazed. The marginal ornamental band is composed of yellow-glazed, successively scrolling vines. **(Fig. 147)**

Type D. The main decorative components are three white- and yellow-glazed lotus rosettes which are floating in one line on the green-glazed wave background. In some cases, extra green-glazed lotus rosettes are added. While the interior vertical walls of the dish are usually yellow or green-glazed, there are also rare cases of white. The marginal ornamental band is composed of yellow or green-glazed, successively scrolling vines. **(Fig. 148)**

It is possible to differentiate between four layout types among the decorations of three-color-glazed eight-lobed dishes.

Type A. A yellow and green-glazed lotus rosette surrounded by four symmetrically arranged small, simple, green-glazed flowers make up the principal designs of this type. Eight lotus flowers appearing in two different shapes and colors - yellow and green - are alternately set along the inside of the eight-lobed contour. The background is made up of a white-glazed waterwave design. **(Fig. 149)**

Type B. The main component of this layout is a yellow- and green- (or yellow and white-) glazed lotus rosette in the center of the vessel's interior. Furthermore, four yellow-glazed lotus flowers and four yellow-glazed peony flowers are alternately

arranged along the inside of the eight-lobed contour. The background consists of a green-glazed waterwave design. (**Fig. 150**)

Type C. The key design is a big, overlapping lotus rosette which fully covers the vessel's interior and has a yellow-glazed lotus seedpod at its center. From the middle to the outer layer of the lotus design, yellow, white, and green glazes alternate. (**Fig. 151**)

Type D. Analogous to Type C, the main design is also a big overlapping lotus rosette fully covering the interior with a seedpod at its center. The only difference between Type C and Type D lies in the shape and the layout of the lotus itself. (**Fig. 152**)

Only one type of layout can be observed among three-color-glazed square dish decorations (**Fig. 153**).

It is a green- and yellow-glazed peony rosette with four green leaves placed on the interior bottom. The designs depicted on the four slopping interior walls are arranged into eight panels, two on every wall, each of which shows a small, yellow-glazed flower with four petals. The panel-frames are adorned with transformed green-glazed leaves with yellow or white stems. The background is white-glazed.

There are four layout types among the decorations of three-color-glazed round dishes.

Type A. In this case the major designs consist of a lotus rosette with slightly S-curved, green-glazed petals as well as a yellow-glazed seedpod surrounded by three groups of a "single, yellow-glazed peony flower with double, green leaves" structure. The outer layer of the interior design consists of three groups of the "single, yellow-glazed peony flower with double green leaves" and three yellow-glazed butterflies (or bees) which are arranged alternately alongside the inside edge of the round dish. The background is of a white color (**Fig. 155**).

Type B. A yellow-glazed lotus rosette with slightly S-curved petals and four groups of white-glazed cirrus illustrations on the background of green-glazed waterwave patterns compose the main designs of this type. The outer layer of the interior designs is the depiction of a cirrus cloud (**Fig. 156**).

Type C. The key component of this decoration is a yellow-glazed lotus rosette with slightly S-curved petals. It floats on a green-glazed waterwave circle and is surrounded by three groups of the "single yellow-glazed peony flower with double green leaves" pattern. The outer layer of the interior design consists of three groups of the "single yellow-glazed peony flower with double green leaves" and three yellow-glazed cirri. They are alternately arranged along the inside edge of the round dish. The background is white (**Fig. 157**).

Type D. The principal designs are a yellow- and green-glazed lotus rosette with slightly S-curved petals and four small leaves surrounded by four groups of the “single yellow-glazed peony flower with double green leaves” pattern. The outer layer of the interior design consists of an alternating arrangement of three groups of the ‘single yellow-glazed peony flower with double green leaves’ subject and three yellow-glazed cirri along the inside edge of the round dish. The color of the background is white (**Fig. 158**).

It has been shown that different layout routines occur on different shapes of three-colored earthenware, and the following analysis demonstrates that the same is true for the decorations on three-colored inkstones, brush-washers, and boxes. The outer walls of both the inkstone and the brush-washer were frequently divided into eight decorating panels. The “single yellow-glazed peony flower with double horizontal green leaves” design was the most popular motif applied to these panels (**Fig. 159**). In cases where there are no panels, the outer wall is decorated with scrolling peony designs instead (**Pl. 333**). On the surfaces of inkstones, only peony (**Fig. 161**) and lotus (**Pl. 336**) designs ever occur. Sometimes, the peony spray is planted in a flowerpot, which then constitutes the main designs of the inkstone-pool (**Fig. 161**). The eight panels of an extraordinary brush-washer example unearthed from the XLZZ3 tomb are each decorated in relief with a human-taming-a-lion motif (**Fig. 160**). The panels are alternately glazed in yellow and green. On the outer wall of Type Ba boxes, there are four sections in accordance with the four-lobed shape of its body. In most cases, each of these sections is adorned with the “single yellow-glazed peony flower with double horizontal green leaves” motif (**Fig. 162, Pl. 338**).

4.2.3 Techniques

Concerning the technical approach to body decoration, Liao ceramics were mainly produced according to traditional techniques of China proper of the Song and Tang dynasties. Progressive breakthroughs and innovations have not been registered in this field. Generally, the decorative skills which can be observed in Liao ceramics are rougher than those exhibited by Song pieces. Accordingly, there is a lack of delicate products to be observed among Liao ceramics.

More particularly, incising (carving) and molding, as well as the carved and the applied relief etc., all rank among the decorative techniques of Liao ceramics. Furthermore, the cutting and the painting method which are both executed on glaze or slip, ought to be mentioned in this context.

4.2.3.1 Incising & Carving

In the production of Liao ceramics, the techniques of incising and carving were influenced by both the Yue wares of the Five Dynasties Period and the Ding wares of the Song dynasty. Notably, the Liao treatment was comparatively unrefined and sketchy. They produce an untrammelled effect which is extremely different from the delicate and elegant appearance of many of its Song counterparts.

It appears that there are two types of Liao incisions.

The first one was achieved by a very quick movement which caused thin and often curved lines. It can be observed in the peony designs of many phoenix-head and long-neck vases (**Pl. 250, Pl. 253**).

The second type is bolder with both more deeply incised and more rigidly curved lines. The simple scrolling vines which can be found on many bag-shaped pilgrim flasks of Type B , Group1 are typical examples thereof (**Fig. 77- Fig. 82**). Similarly strong incisions can be found on the bag-shaped pilgrim flasks housed in the Liaoning Provincial Museum; however, it is important to note that in this particular case the lines were incised through a layer of white slip, according to a technique which belongs to the Cizhou tradition (**Pl. 259**). Occasionally, incisions of the second type can be so stiff and rigid as to lose any sense of fluency (**Pl. 254-Pl. 256**).

The finest and most exquisite kind of Liao carving techniques can be observed on Ding wares. The ewer discovered in the GYY tomb, for instance, demonstrates that the Ding type of lotus petals was closely imitated by Liao potters, even though their stiffer carving technique makes the petals appear slightly less tender (**Fig. 53**).⁴⁸⁶ Carvings which are similar except for more intricately executed designs, can be found on a bowl from the DXG1 tomb (**Fig. 45**)⁴⁸⁷ and a ewer from the SJG1 tomb, dated to 1002 (**Fig. 52**).⁴⁸⁸ The ewer excavated from the NLZ tomb was also finished in Ding-style (**Cat. 491**)⁴⁸⁹, i.e. with a deeply carved relief design with finely incised butterflies and details of the scroll. A different treatment can be found on white wares with peony designs, whereupon carving is merely applied to define the contours of the design, whereas details are described by incisions. Consequently, instead of being elevated, the designs remain on the same plane as the grounding. Excavated examples of this particular kind

486 Zhu Zifang & Xu Ji 1983, 168-95.

487 Xin Yan & Hua Yubing 1991, 40-47.

488 Deng Baoxue et al. 1983, 30-38, fig. 15

489 Liaoyangshi wenwu guanlisuo 1977, 90-91.

are the dish-mouthed ewer unearthed at Tongliao, Inner Mongolia (**Cat. 446**), and the jar from a tomb at Niuyingzi, Kalaqin Banner, Inner Mongolia (**Cat. 647**).⁴⁹⁰

Another member of the family of incising and carving methods is a certain Cizhou tradition which can be observed on a group of heavy jars with a thick mouth rim.

One type of said Cizhou tradition is sgraffito, i.e. the incision of a design which is subsequently cut out of the white slip layer to reveal the naked clay body underneath; details of the design are sometimes combed. This technique can be found on some meiping vases (**Pl. 277**) and dish-mouthed vases (**Pl. 265-Pl. 266**). Only the GWYC kiln sites ever produced ceramics with this kind of decoration (**Pl. 12**).

However, a more innovative type of the Cizhou tradition also exists. According to this method, peony scrolls were also incised and further described by combed lines, but the ground area was filled with a black glaze instead of being cut away, resulting in a strong color contrast between the white design and the black background (**Pl. 267-Pl. 273**). Again, only the GWYC kiln sites ever produced ceramics with this kind of decoration (**Pl. 10**); no Song Cizhou-type wares are known to have ever been decorated in this way. In cases where the floral scroll was only incised and combed without any further treatment (**Pl. 274**), the quick movement and the skillful control of the incising instrument are best revealed. A very rare method, which has so far only ever been found on some phoenix-head vases (**Pl. 278**), is to combine sgraffito with an additional green glaze. The cutting was rigidly performed, giving the floral scroll an extremely stiff appearance which lacks the usual forceful movement of other Liao sgraffito designs.

4.2.3.2 *Molding*

The Liao molding technique was predominantly applied to lead-glazed ware, but it also appears in white ware. In the process, a decorative object was prepared on a mold before it was impressed onto a vessel. As the method allowed for a more careful and precise carving during the preparation of the mold, meticulous and neatly composed designs as well as formal ones were produced. They greatly differ from the free and sketchy decorations effected by incision and carving. The layouts on a number of oblong-lobed dishes, eight-lobed dishes, square dishes, round dishes, and inkstones exemplify the possibility to achieve highly complex ornamental compositions by molding (**Fig. 145-Fig. 161**). The most intricately molded piece of Liao ware which is known seems to be the ewer in **Cat. 518**. Wave patterns, scroll designs, and some unidentified motifs are densely arranged on to create a very elaborate decorative effect.

490 Feng Yongqian 1981, 65-71.

Molding is a technique which had already been practiced by Chinese potters of the 7th century and was retained down to the late Tang dynasty and the Five Dynasties Period. Molded ornaments were often affixed to metalwork⁴⁹¹ and the Liao molding technique almost certainly is a continuation of this tradition, seeing as its molded designs, the vessel forms to which they were applied, as well as the symmetry of the designs are frequently close copies of metallic prototypes. The question why the technique was not commonly used by Liao potters before the mid-11th century, however, remains unsettled. It is known that Ding potters in Hebei employed molding for decorative purposes roughly from the very late Northern Song onwards. Accordingly, the Liao molding technique emerged much earlier than the Ding one, and it is thus doubtful whether the latter ever affected the former in any way. Moreover, molded Ding designs have a general effect of extravagance and exquisiteness which can hardly be related to the symmetrically and stiffly composed Liao ornaments.

Counting among the various molding instruments unearthed at the GWYC kiln site are exemplars intended for Liao oblong-lobed dishes (**Fig. 3**), square dishes, round dishes (**Pl. 43**), ewers (**Pl. 42**), ocarinas, inkstones, figures, etc. At the LQW kiln site several molding instruments for square dishes were discovered (**Fig. 18**). Furthermore, tools intended for small figures were located at GGT (**Pl. 71**).

4.2.3.3 *Applied Relief*

To decorate in applied relief is to attach molded or hand-modeled ornaments onto a vessel. Before Liao application, this technique was commonly used by Tang potters, particularly on three-colored ware with designs which were predominantly based on metalwork and created a rich decorative effect.⁴⁹² Liao designs in applied relief appeared quite early, evidenced by bag-shaped pilgrim flasks of Type B Group 1 (**Pl. 316**), which were popular during the late 10th to early 11th century. Ranking among the used motifs are the phoenix, the dragon, the cloud scroll, the flaming pearl, the crawling child, the mandarin duck, etc. In contrast to Tang-type patterns, the majority of the Liao applied relief designs can scarcely be related to metalwork.

A group of green-glazed ware discovered in the QCH tomb and dated to 1004⁴⁹³ should also be included in the category of Liao applied ornaments dated to a time before the mid-11th century. The design on these green-glazed pieces is composed of a horizontal

491 Goto Shigeki ed. 1976, pls. 9, 25, 26, 40, 41, 256-58.

492 Goto Shigeki ed. 1976, pls.33-39.

493 Jin Fengyi 1980, 44-51.

band of small petals which point either upwards or downwards (**Cat. 399**). The same ornaments can be observed on lugged vases of Type B from the YLYZ tomb and dated to 942 as well as from a tomb at Shantiaomao, Qinshuihe, Inner Mongolia (**Cat. 248, Cat. 249**). They also appear on bag-shaped pilgrim flasks of Type B Group1, discovered at a tomb in Guangdegong township, Wengniute Banner, Inner Mongolia (**Cat. 61**), on ewers of Type Cf like the one unearthed from the foundation of a pagoda at Dingxian, Hebei, dated to 977, and on Types Aa and Aa (**Cat. 380, Cat. 381, Cat. 382, Cat. 499**).

The most distinguished type of Liao applied decorations is probably represented by the raised ridges and bosses of pilgrim flasks (**Cat. 105-Cat. 135**). These were not applied merely for ornamental purposes, but were direct copies of the seams and studs represented on their leather prototypes. One bag-shaped pilgrim flask from the Avery Brundage Collection, Asian Art Museum of San Francisco, is decorated with additionally applied tasseled ropes, clearly imitating the original decoration of the leather bags (**Cat. 219**). The mock leather straps affixed to the green-glazed long-neck vase from a tomb at Ningcheng, Inner Mongolia, have the same significance (**Cat. 326**).

Quite a different style is represented by the adornments added to some white, porcellaneous, melon-shaped ewers. Molded ornaments of butterflies, fish, or floral medallions were attached to the loop-handle, creating a highly sculptural effect (**Cat. 489**). The ewers unearthed from the ZKY tomb (**Cat. 490**) and from a tomb at Nanlinzi, Liaoyang city, Liaoning province (**Cat. 492**), in particular, are equipped with many small, ball-like floral medallions along the edges of their mouths, thus constituting the most intricately decorated examples of Liao ceramics.⁴⁹⁴

4.2.3.4 *Painting*

The green-glazed basin painted with a lotus rosette in colored pigments which was discovered in the QCH tomb (**Cat. 719**) evinces that painting techniques were already practiced by Liao potters during the early part of the Liao dynasty.⁴⁹⁵ However, this particular decorative technique did not further develop until the last years of the said dynasty, during which some slipped vessels were painted with floral designs in black or brown, i.e. particularly small jars bearing two loop-handles on their shoulders. The designs were achieved with only very few strokes of iron oxide and are so simple that they cannot be identified more specifically. Excavated examples came from Wushijiazhi,

494 Liaoyangshi wenwu guanlisuo 1977, 90-91; Deng Baoxue et al. 1983, pp. 30-38, fig. 15.

495 Jin Fengyi 1980, 44-51.

Jianping, Liaoning (**Cat. 578**), and Nailingao, Aohanqi, Inner Mongolia (**Cat. 687**).⁴⁹⁶ Liao wares of this type are known to have been produced by the GWYC and GTT kiln sites.⁴⁹⁷ Some Cizhou-type wares of the late 11th to 12th century appear to be the earliest exemplars decorated in this manner⁴⁹⁸ and can be assumed to have influenced Liao iron oxide painting techniques.

4.3 INSCRIPTIONS

Some Liao ceramics bear inscriptions. They are most often incised (**Pl. 343-Pl. 359**), but cases of black-ink handwriting (**Pl. 342**) also occur. The engravings contain valuable information and are quoted as evidence of production areas and datings in the studies of Liao ceramics. According to their specific function, three categories of inscriptions can be classified.

1. Indicating dating.

The shoulder of chicken-leg vases is frequently incised with either Chinese or Khitan characters reading, for instance, "Qiantong such-and-such year 乾统某年", Qiantong denoting the era named after Liao's last emperor, which lasted from 1101 to 1110. Exhibits thus inscribed can be found in collections of the Liao Provincial Museum (**Pl. 343-Pl. 345, Pl. 347, Pl. 348**).

A three-colored molded earthenware, bearing the incised inscription "Shouchang fifth year"(寿昌五年) was recovered from the LQW kiln site. Shouchang denotes the era named after the Liao emperor Daozong which lasted from 1095 to 1101; the object was dated to 1099. (**Pl. 349**)

Incised on a white-glazed vase which was unearthed at Wulantaohai, Inner Mongolia, is the inscription "Da'an 9th year"(大安九年). Again, Da'an denotes an era named after a Liao emperor, namely Daozong which lasted from 1085 to 1094; the object was dated to 1094. (**Fig. 163**)

2. Indicating producer or owner.

In some cases, it was the first name of the craftsman which was incised on ceramics so as to indicate either the producer or the owner of the vessel. A basin and a vase contained in the Guan Baocong collection are samples of this kind. They are incised respectively with the first names Nian 年 (**Pl. 350**) and Zhao 赵 (**Pl. 351**).

3. Indicating the property of the kiln.

496 Shao Guotian 1980, 94-95.

497 Li Wenxin 1958, 10-22; Jia Zhoujie 1973, 241-43.

498 Li Huibing 1964, 37-48, fig. 8.

On a number of white-glazed, finely made Liao porcelain wares, incised guan or xinguan inscriptions can be found. Guan (官) being Chinese for “official”, and Xinguan (新官) for “new official”. Examples of this sort of marking can be discovered on some white-glazed bowls (Pl. 354, Pl. 355, Pl. 358, Pl. 359), ewers (Fig. 165, Fig. 166), jars (Fig. 167), bottles (Fig. 164), long-neck vase (Pl. 357), lugged vases (Pl. 356) and bag-shaped pilgrim flasks of the Early Liao period.

Of these categories of inscriptions, it was the guan (official) and xinguan (new official) marks which attracted the most attention and caused in depth discussion. While some of the excavated white wares which are incised on their base with these particular marks stem from Liao sites, other exemplars were discovered in areas outside Liao territory, including Hebei, Zhejiang, and even a place as far south as Hunan. The guan- and xinguan-marked wares, the total number of which is about one hundred to date, form a special group among Chinese ceramics. To specify their dates and places of manufacture and to understand the significance of the inscribed characters has become both a challenge of Chinese ceramic studies as well as an indispensable part of advancing the field. While bowls occupy the dominant position among these one hundred pieces of guan- and xinguan-marked ceramics, other forms also occur, including jars, vases, boxes, basins, kundikas, and dishes. Even shapes with non-Chinese characteristics, such as bag-shaped pilgrim flasks, dish-mouthed vases, and lugged vases belong to the group. The guan and xinguan marks were applied either to the flat base or within the ring-foot, and executed by incision after glazing, yet, before firing. Only in very rare cases was the mark incised before the body was coated with glaze. The characters appear mostly in a running script which has a thin and long structure, however, sometimes they are written in a regular or a cursive script.

While these types of ceramics are known to have been commonly produced during the late Tang period, they have only ever been found in South China; they continued to be produced during the Five Dynasties period. The bowls discovered in the ZDJ tomb (958), and the bowls and dishes unearthed from the FMM tomb (959), represent the earliest guan- and xinguan-marked ceramics found in dated tombs in the north of China.⁴⁹⁹ In 1969, seventeen pieces of similarly marked vessels were discovered in the foundations of Pagoda at Dingxian, Hebei, dated either to 977 or to the early Song dynasty.⁵⁰⁰ These finds prove that guan and xinguan marked wares were still being produced during the early part of the Song dynasty.

As archaeological evidence has shown, most guan- and xinguan-marked white wares were unearthed from sites which can hardly be dated to a point in time later than the

499 Beijingshi wenwu gongzuodui 1962, 246-52; Zheng Shaozong 1956, 1-26.

500 Dingxian bowuguan 1972, 39-51.

10th century. Even those few examples recovered from 11th century sites bear characteristics of ceramics from the previous century. For instance, two guan-marked, covered jars, one unearthed from the Liao GYY tomb (1020), the other from a pagoda at Shunyi, Beijing, (1031), are decorated with carved, overlapping lotus petals.⁵⁰¹ As such they are analogous in form and decoration to those jars found in the foundations of Pagoda at Dingxian, Hebei, dated to 977. Furthermore, the four guan-marked triangular dishes discovered in a Late Liao tomb at Dawopu, Chifeng, Inner Mongolia, show parallels to examples from a Five Dynasties tomb at Changsha, Hunan.⁵⁰² Therefore, it seems quite possible that guan-marked vessels recovered from 11th century Liao sites were actually fabricated at a point in time as early as in the 10th century, and that the production of guan- and xinguan-marked ceramics had already ceased before the beginning of the 11th century.

The provenance of guan- and xinguan-marked ceramics is a problem which has evoked much controversy. When four pieces of guan-marked vessels were unearthed from the FMM tomb in 1954, two conflictive opinions concerning their origin emerged. On the one hand, it was argued that guan-marked white wares, like similar unmarked white wares, were products of an official Liao kiln.⁵⁰³ On the other hand, it was stated that high quality white wares were produced by Ding kilns at Quyang, Hebei had been used in the Early Liao period, and that guan-marked vessels should accordingly be identified as Ding ware as well.⁵⁰⁴ Fortunately, the recovery of further archaeological evidence since the 1950s has resolved the dispute, showing that both Ding and Liao kilns produced ceramics marked in such a way.

The fact that many guan- and xinguan-marked ceramics were not only discovered in Liao tombs but also often occurred in typical Liao forms, has led some archaeologists to believe that these inscribed wares were also produced at Liao kilns. Coincidentally, both guan-marked (Pl. 352) and xinguan-marked (Pl. 353) kiln instruments have been recovered from the Liao GWYC kiln site at Chifeng, Inner Mongolia⁵⁰⁵, a find which indicates Liao ceramics, too, could bear a guan- or xinguan-mark. Hence, the guan-marked vessels discovered in the FMM tomb, are now generally accepted to be

501 Zhu Zifang & Xu Ji 1983, pp. 168-95; Su Tianjun 1964, 49-53.

502 Zheng Long 1959, 47-48; Hunansheng bowuguan 1966, 159-160.

503 Chen Wanli 1956, 15-16.

504 Li Huibing 1983, 70-77; Feng Xianming 1959, 67-70.

505 Feng Yongqian 1984, 386-92.

products of the GWYC kiln.⁵⁰⁶ As evidenced by the guan-marked shards collected by Koyama Fujio in 1944⁵⁰⁷ at the SJY kiln site, this tract at Lindong, Inner Mongolia, is another Liao kiln which produced guan-marked ceramics. Moreover, the lugged vase inscribed with the character guan which was discovered in the ruins of Shangjing city appears to be another sample fabricated at the SJY kiln.⁵⁰⁸

As for the significance of the inscriptions, the character guan naturally leads to the inference that the ceramic industry was officially sponsored. Chinese archaeologists now generally accept the GWYC and the SJY kilns to be those official Liao kilns mentioned in old Chinese documents, and that Liao guan-marked wares were products thereof.⁵⁰⁹ However, the official status of similarly marked works of Ding kilns remains questionable. After all, the tombs and pagodas in which they were located do not indicate a high status. Basil Gray suggests that the character guan probably stands for “as supplied for government service” and not necessarily that the wares were made by an official kiln.⁵¹⁰ Li Huibing likewise disregards the proposition that Ding guan-marked ceramics were official wares. Based on the fact that guan-marked wares can be found in Liao territory and even in places as far off as Faustst, Egypt, he considers the character guan likely to be a mark of goods ordered by bureaucrats and foreign countries.⁵¹¹ I agree with both Basil Gray and Li Huibing, and am inclined to regard Liao guan- and xinguan-marked ceramics as supplies for government service, which were either used by bureaucrats or served as presents to other countries. As has been shown, it is not necessarily a given that these wares were made by an official kiln.

506 Zheng Shaozong 1956, 1-26.

507 Koyama Fujio 1962, 69-81.

508 Wang Qing 1979, 3-14.

509 Zhongguo guisuanyan xuehui 1982, 71.

510 Gray 1984, 58.

511 Li Huibing 1983, 70-77, fig.1.

CHAPTER 5 MANUFACTURAL TECHNIQUE

5.1. THE FORMING AND THE RAW MATERIALS OF THE BODIES

Several methods of forming were executed in the production of Liao ceramics, predominantly throwing and molding, but also kneading, slab-making, press-molding, and so on. Prior to the actual shaping procedure, the clay was prepared by the addition of water, which accounts for some 10-30% of its plastic weight and activates its potential plasticity. The liquid surrounds and lubricates the platy minerals in the clay, allowing them to shift under pressure and thus making plastic forming possible.

5.1.1. Throwing

Throwing is the basic technique for the forming of circular wares, such as the round bowl and the dish, as well as the globular or ovoid jar, bottle, vase, ewer, and so on.

In the course of the throwing process, the potter tosses a ball of clay onto the center of the wheel-head, then immediately adds water and firm pressure to make it run true.

Once the clay is centered, pressure is again applied to open a well in its middle.

Subsequently, the thick walls of the vessel are gradually thinned by pressing a hand on either side of them, which causes them to rise and enlarges the pots volume. The rim is regularly steadied and compressed as the making proceeds. Water or slip is applied to the spinning clay in order to reduce friction from the hands; otherwise the soft and spinning vessel might buckle and collapse. Although it is not apparent to the viewer (or even to the thrower), the clay particles in a pot's wall may be dragged around in a spiral in as many as three complete turns due to the friction from the potter's fingers.⁵¹²

In throwing, the vessel is always firmly attached to the wheel-head by exploiting the natural stickiness of clay. It therefore needs to be cut off when the shape is finished by using a thin string, wire or, less frequently, a fine blade.

512 These spiral travels can also persist during firing, as the vessel, which is still affected by the original drag applied in its making, continues to twist slightly in the counter direction of the original spin of the wheel. See Cardew 1969,122, for a more detailed discussion of the effect.

Turning is a subtractive process which cannot begin before the clay is at least leatherhard.⁵¹³ The process, however, can be considerably sped up by returning the wares to the wheel, securing the vessels or covers upside-down, and turning away excess clay in a manner reminiscent of wood-turning, even though, in practice, clay offers much less resistance to the cutting blade than wood. Turning was usually employed to finish the feet of vessels, to form foot-rings, or to complete lids and covers. In Chinese porcelain manufacturing, it is often applied to entire porcelain forms, both inside and out, in order to provide the most accurate profiles and sections possible. After the turning procedure, any desired springs, handles, or spouts could be added to the form.⁵¹⁴ Moreover, the clay, containing only about 5% water right before it dried, could be burnished by rubbing it with a hard, smooth tool. Afterwards, the vessels would be allowed to dry completely. It is probable that some final cleaning or fettling occurred before they were set in the kiln for firing. Each of these making and finishing stages would only be attempted when the potter judged that the water content was suitable for the next process: usually by letting the objects dry evenly in a controlled environment.

5.1.2. Molding

Liao's ceramic production mainly applied the molding technique to the making of some irregular shapes with molded designs, such as square dishes, oblong-lobed dishes, ewers in different zoomorphic forms, globular ocarinas, etc. The majority of molded Liao products are low-fired three-color lead-glazed earthenware, only a few pieces of which are white-glazed porcelain.

The molding procedure entailed the pressing of thin slabs of clay into hollow molds. Ceramics that were entirely molded and fabricated in China first appeared in legion in burial wares of the Han dynasty during the late Bronze Age, then reappear in large quantity among lead-glazed wares of the Tang dynasty. For hundreds of years thereafter, molding became the second most popular technique at most Chinese kilns sites after throwing.

513 The term 'leatherhard', used widely in the "**pottery industry**", is probably derived from the English country pottery tradition, where local earthenware clays tended to become unusually tough and leathery in their half-dry states, feeling to the touch like old leather flagons or leather buckets. The term was carried over from the north Staffordshire pottery industry although the clay-poor prepared bodies, eventually developed for making white earthenware and bone China in Stoke-on-Trent, were less obviously leathery at this stage of drying.

514 If spouts and handles are set high on the form, they are more likely to have been attached before than after turning (which generally only removes the thicker clay towards the vessel's base).

In practice, clay slabs or plastics which had been pressed into open molds, released themselves again as they shrank during drying. In order to make closed vessels, molded sections were often joined while they were leatherhard. This inevitably resulted in the objects having one good side (from the mold face) and a rougher side (from where the clay was pressed into the mold).

Molding instruments were discovered at many Liao kiln sites like GWYC, LQW, and GGT. For example, **Pl. 42**, which was discovered at the GWYC kiln site, is a molding instrument for a ewer. The corresponding ceramic should be the three-color lead-glazed ewers in **Cat. 425**. **Cat. 1143** is the molding instrument of a square dish recovered from LQW, the appendant ceramic ought to be the three-colored square dish from **Cat. 1144**.

5.1.3. Other Methods of Forming

Apart from throwing and molding, freehand kneading constitutes another important forming method in the production of Liao ceramics. It was especially popular in the making of small, animal-shaped toys, like ocarinas and chessmen. The potters used their hands to knead the plastic clay into vivid shapes of animal or human figures according to their personal inclinations. The procedure is both the most primitive but also the most flexible and inventive of ceramic forming techniques. At the GWYC and the GGT kiln site, plenty of such toys and figures have been (**Pl. 109-Pl. 114**, **Pl. 161-Pl. 164**), most of them high-fired stonewares.

Regarding the making of the handle and spout of some ewers, other forming techniques than those applied to the body, occur. For instance, tubular spouts, intended for Liao ceramic copies of metal ewers, seem to have been made from thin slabs of clay which had been folded, joined, and smoothed around a tapering core. The latter was then removed before the spouts were bent slightly in imitation of the metal originals. The ewers' handles tended to be made from cut strips of clay which had been smoothed into sections before being bent into shape. Both procedures are more closely related to metal working than to typical pottery-based techniques, according to which throwing would have been applied to the spouts and 'pulling' to the handles.

5.1.4. Different Varieties of the Bodies

Prior to a discussion of the body materials of Liao ceramics, it is necessary to introduce and explain the definitions of different ceramic varieties.

In modern English-language sources, ceramics are categorized due to the material of their body to either belong to the class of earthenware, or stoneware, or porcelain.

Porcelain has been described as: ⁵¹⁵

A vitrified, white and translucent ware... that is fired at 1,300 plus. The name porcelain is said to have been coined by Marco Polo in the 13th century from porcelino. This was the name of the translucent cowrie shell which looked like a little pig or porcelino. He likened Chinese porcelain to this translucent white shell.

As a matter of fact, Chinese porcelain is not necessarily either white or translucent. Porcelain stones and clays may contain impurities, such as iron oxide, which discolor them to appear brown, or grey, or yellow in their raw state, and result in a grey tone after firing. Moreover, if an object is thickly potted, it will not conduct light through its walls. Even the firing temperature varies in the range of 1,150-1,400 .

Stoneware has been characterized as a hard, strong, and vitrified ware, fired above 1,200 , the body and glaze of which mature to form an integrated body-glaze layer.⁵¹⁶

Earthenware has been defined as having a porous body which can be waterproofed by glaze. Furthermore, the simplest distinction between stoneware and earthenware has been specified as follows: ⁵¹⁷

If the fired body has a porosity of more than 5 %, then it is earthenware. Many potters add to this criterion of porosity a consideration of the temperature at which the glaze is fixed. The softer temperatures below 1,100 ...are associated with earthenware glazes...

Provided that the quoted terminology of earthenware, stoneware, and porcelain is accepted, the history of China's earthenware roughly begins in the Palaeolithic, that of stoneware at an early point in the Bronze Age, and that of porcelain in the late 6th century. However, two problems result from the distinctions between body varieties as outlined above: firstly a technological consideration, and secondly a linguistic dilemma.

As for the technological complication, in China (particularly in the north) many types of stoneware fall into the 'earthenware' porosity range, due to the refractoriness of their

515 Hamer & Hamer 1975, 229.

516 Hamer & Hamer 1975, 285.

517 Hamer & Hamer 1975, 111.

raw materials.⁵¹⁸ Hence, in most (not all) Chinese wares, the critical difference between earthenware and stoneware can only be marked by the significant development of mullite ($\text{Al}_6\text{Si}_2\text{O}_{13}$) crystals in a ceramic body. Unfortunately, this is a factor which can only be determined by microscopy and not by the naked eye.

In linguistic terms, too, Chinese criteria for porcelain, stoneware, and earthenware differ from the tripartite system described above. Etymologically speaking, the modern Chinese language divides ceramics into only two types, Tao 陶 and Ci 瓷. On the one hand, the lower-fired Tao material corresponds to what English defines as earthenware but also to some categories of stoneware. High-fired Ci, on the other hand equates to both stoneware and porcelain. Consequently, it is possible that in Western translations of Chinese, material that would be regarded as stoneware is referred to as 'porcelain'.

5.1.5. Earthenware (or Tao 陶 in Chinese)

According to western standards, the body classifications of Liao ceramics distinguish three varieties: earthenware, stoneware, and porcelain wares.

Glazed Liao earthenware mainly occurs in the group of low-fired, three-color or monochrome lead-glazed ceramics. However, a few exemplars also appear among those low-fired three-color borax-glazed ceramics which were recovered from the LQW kiln site. The glazes are applied to low-firing loess clays. Analogous to wares during the Han and the Tang dynasties in northern China, glazed earthenware vessels during the Liao dynasties mainly functioned as burial objects or to as objects of utility.

The following Table 6 illustrates the chemical composition of the raw materials of the bodies of Liao three-color lead-glazed ceramics which were recovered from the GWYC kiln site.

Table 6 The chemical composition of raw materials of the bodies of Liao three-color lead-glazed ceramics⁵¹⁹

No.	SiO_2	Al_2O_3	Fe_2O_3	TiO_2	CaO	MgO	K_2O	Na_2O	Loss in firing

518 Porosity is only a vague term if no distinction is made between “open” and “closed” porosity (also called “apparent” and “true” porosity). Many Chinese stonewares have a percentage of water absorption greater than 5%: for example, Ru ware 19.3%; Jun ware 10.7%; Linru wares up to 8%. A full account of standard industrial ceramic investigation into Chinese ceramics, including porosity, is detailed in Palmgren, Sundius & Steger 1963, 452-75.

519 Guan Baocong & Ye Shuqing 1985.

Raw material of body 1#	57.11	29.03	1.73	0.71	1.78	0.47	1.39	0.53	6.50
Raw material of body 2#	54.09	32.22	1.37	1.35	0.70	0.31	2.28	0.89	6.54

The chemical composition of the bodies of Liao three-color lead-glazed ceramics from the GWYC kiln site will be displayed in Table 7.

The data demonstrates that the bodies contain about 28% Al_2O_3 , 2% Fe_2O_3 , and 1% TiO_2 by weight. The relatively high levels of Fe_2O_3 and TiO_2 cause the white body to appear in a pinkish or yellowish tone. The crystal phase of the body is relatively coarse, as it contains mainly quartz, feldspar, hematite, clay agglomerate, and little mica, etc.

Table 7 The Chemical Composition of the bodies of Liao three-color lead-glazed ceramics⁵²⁰

No.	SiO ₂	Al ₂ O ₃	Fe ₂ O ₃	TiO ₂	CaO	MgO	K ₂ O	Na ₂ O	Loss in firing
LSC-2 # (body of a three color glazed bowl)	63.33	27.04	2.15	1.06	2.78	0.52	1.76	0.84	0.93
LSC-3 # (body of a bowl)	59.55	29.54	1.80	1.14	3.43	0.37	1.21	1.15	1.67
LSC-4 # (body of a green-glazed, bag-shaped pilgrim flask)	61.62	28.19	2.34	0.87	2.78	0.52	1.52	0.60	1.70
LSC-5 # (body of a yellow-glazed bowl)	62.84	28.67	2.10	1.27	2.03	0.39	1.04	0.98	0.91
LSC-6 # (body of a yellow-glazed vase)	62.02	27.88	2.50	1.09	2.22	0.38	2.08	0.74	1.16
LSC-7 # (body of a three color glazed square dish)	62.70	26.50	2.67	1.03	2.09	0.41	2.44	0.97	0.74
Row material of body 1#	57.11	29.03	1.73	0.71	1.78	0.47	1.39	0.53	6.50
Row material of body 2#	54.09	32.22	1.37	1.35	0.70	0.31	2.28	0.89	6.54

Below, Table 8 illustrates the sintering temperature and physical properties of the bodies of Liao earthenware from the GWYC kiln site.

520 Guan Baocong & Ye Shuqing 1985.

Table 8 The sintering temperature and physical properties of the bodies of Liao earthenware⁵²¹

No.	Sintering temperature(%)	Water absorption(%)	Porosity(%)	Expansion coefficient×10-6/ (Room temperature ~ 800)
LSC-2#	1120±20	12.92	25.03	6.4
LSC-3#	970±20	14.19	26.79	
LSC-4#	960±20	14.52	27.15	
LSC-5#	1010±20	14.11	26.83	
LSC-6#	1100±20	14.00	26.40	
LSC-7#	1150±20	11.70	23.74	5.9

The following Table 9 shows the composition of Liao dynasty borax-glazed earthenware bodies from the LQW kiln site.⁵²² The bodies contain 32% Al₂O₃, and 1% iron. The low level of iron and the disappearance of titanium account for the relatively pure white color of the body.

Table 9 The composition of Liao dynasty borax glazed earthenware bodies from LQW kiln site⁵²³

NO.	SiO ₂	Al ₂ O ₃	Fe ₂ O ₃	CaO	MgO	K ₂ O	Na ₂ O	Pbo	B ₂ O ₃	CuO	MnO	P ₂ O ₅	Total
1	57.1	32.9	0.6	0.6	0.2	1.7	4.0				0.01	0.1	98.2
2	58.6	32.2	1.6	0.5	0.2	1.9	3.1					0.1	98.2

The sintering temperature and physical properties of Liao dynasty borax-glazed earthenware bodies from LQW kiln site are presented below in Table 10 .⁵²⁴

521 Guan Baocong & Ye Shuqing 1985.

522 Chen Yaocheng et al. 1989, 317-21

523 Chen Yaocheng et al. 1989, 317-21

524 Chen Yaocheng et al. 1989, 317-21

Table 10 The sintering temperature and physical properties of Liao dynasty borax glazed earthenware bodies from LQW kiln site⁵²⁵

No.	Sintering temperature of bodies(±20)	Porosity (%)	Water absorption (%)	Bulk density (g/cm ³)	Pseudo-specific gravity (g/cm ³)
JL1	1000	27.08	14.41	1.88	2.6
JL2		29.28	14.84	1.97	2.79
JL3	1100	8.27	3.42	2.29	2.48
JL4	1000	24.73	12.99	1.90	2.53

5.1.6. Stoneware and Porcelain (or Ci 瓷 in Chinese)

Liao stonewares mainly occur in the group of high-fired, white, black, brown, or teedust-green-glazed ceramics with relatively coarse bodies, whereas Liao porcelain wares can most often be found among high-fired white wares with very fine corpses. In the modern Chinese language, both Liao stoneware and porcelain are referred to as Ci 瓷.

High-fired, glazed stoneware first appeared in northern China in the 5th century. A rapid growth of the ceramic category ensued during the following century, before the material was succeeded in the late 6th and early 7th centuries by true white porcelains.

In China, the analysis of raw materials local to kiln sites has suggested that most rocks and clays were at least initially taken from deposits close to the centers of pottery production. The majority of northern stoneware clays contain about 50-85% of kaolinitic minerals by weight. High alumina and low potassia levels can be traced both in stoneware and porcelain clay compositions across northern China, a circumstance which implies that most northern stonewares were derived from clay systems similar to the ones in porcelains.

Despite the fact that all three varieties were made from virtually the same clays, Liao stonewares and porcelains were far more difficult to load and fire safely than Liao earthenwares. The discrepancy is largely due to the higher firing shrinkages and greater tendencies to distortion associated with stoneware and porcelain production.

The purple stone rough material was obtained at Shangjing, Lindong township, Inner Mongolia. A multitude of small pieces of kaolinite and purple stones exists near the SJY kiln sites.

525 Chen Yaocheng et al. 1989, 317-21

Table 11 shows the composition of the raw materials in the bodies of Liao white-glazed stoneware and porcelains from Inner Mongolia.

The basic materials of sticky culm clay (Nian Ganzi Tu, 粘矸子土 in Chinese) and hard culm clay (Ying Ganzi Tu, 硬矸子土 in Chinese) both stem from Laoyaoshan, Houtougou township, Chifeng city, Inner Mongolia, near the the GWYC kiln sites. The mineral composition mainly contains kaolinite and quartz. Between sticky and hard culm clays, it is the latter which contains a higher percentage of kaolinite.

The soil calculus (Tujieshi in Chinese 土结石) raw material comes from the region of Shuiquangou, in the proximity of the GWYC kiln sites. The substance appears in white, spherical clumps. Its mineral composition mainly contains calcite (CaCO₃) and a small proportion of quartz. It is one of the materials employed in the glazes of Liao ceramics.

The raw material of Pyrophyllite (Yelashi, 叶蜡石 in Chinese) displayed in The purple stone rough material was obtained at Shangjing, Lindong township, Inner Mongolia. A multitude of small pieces of kaolinite and purple stones exists near the SJY kiln sites.

Table 11 was collected from the Pyrophyllite mine in Balin Left Banner, Inner Mongolia, near the SJY and NSY kiln sites.

Kaolinite and Argil (Bainiantu, 白粘土 in Chinese), shown in The purple stone rough material was obtained at Shangjing, Lindong township, Inner Mongolia. A multitude of small pieces of kaolinite and purple stones exists near the SJY kiln sites.

Table 11, were attained at Daban township, Balin Right Banner, Inner Mongolia.

The purple stone rough material was obtained at Shangjing, Lindong township, Inner Mongolia. A multitude of small pieces of kaolinite and purple stones exists near the SJY kiln sites.

Table 11 The composition of the raw materials in the bodies of Liao white-glazed stoneware and porcelains⁵²⁶

Name of raw materials	Origin	SiO ₂	Al ₂ O ₃	Fe ₂ O ₃	TiO ₂	CaO	MgO	K ₂ O	Na ₂ O	Loss in firing
Sticky culm clay (Nianganzitu)	Dayaoshan in Houtougou, Chifeng, Inner Mongolia	61.37	23.85	0.78	1.19	0.86	0.75	0.87	0.32	9.65

⁵²⁶ Cong Wenyu et al. 1992.

Hard culm clay (Yingganztu)	Nanshan in Houtougou, Chifeng, Inner Mongolia	52.64	32.09	1.00	1.23	0.89	0.12	1.08	0.22	10.17
Argil (Bainiantu)	Daban, Balinyouqi, Inner Mongolia	35.46	35.07	0.14	0.09	0.08		3.48	0.12	25.29
Kaolinite (Gaolingshi)	Shangjing, Balinzuoqi, Inner Mongolia	45.00	39.88	0.19	0.06	0.17	0.12	0.10	0.15	14.24
Pyrophyllite (Yelashi)	Balinzuoqi, Inner Mongolia	66.00	28.85	0.41			0.27			5.24
Soil calculus (Tujieshi)	Shuiquangou, Chifeng, Inner Mongolia	15.13	3.98	1.16	0.19	43.35	0.90	0.69	0.29	34.43
Purple stone (Ziseshi)	Shangjing, Balinzuoqi, Inner Mongolia	61.69	17.19	6.70	1.61	1.79	2.14	1.51	3.76	2.88

The bodies of Liao white-glazed stoneware (coarse ware) contain about 27-28% Al₂O₃, 63% SiO₂, and 2.3-3.3% Fe₂O₃ by weight. The higher Fe₂O₃ content makes their corpses appear darker in color than those of Liao white-glazed porcelains. The iron-rich bodies with a mottled microstructure were often white-slipped to improve the whiteness of their appearance.

Table 12 in the following depicts the chemical composition of the bodies of Liao white-glazed stoneware and porcelains.

As a matter of fact, the raw materials used for the bodies of those so-called white-glazed stonewares and porcelains wares which were produced by the same kiln site are very similar. The only difference lies in their panned degrees, identifiably by the size of crystal particles; accordingly, the bodies of the white-glazed stonewares are coarser than those of the porcelains. As mentioned before, in Chinese, both of them are referred to as *Ci* 瓷.

According to The bodies of Liao white-glazed stoneware (coarse ware) contain about 27-28% Al₂O₃, 63% SiO₂, and 2.3-3.3% Fe₂O₃ by weight. The higher Fe₂O₃ content makes their corpses appear darker in color than those of Liao white-glazed porcelains. The iron-rich bodies with a mottled microstructure were often white-slipped to improve the whiteness of their appearance.

Table 12 the bodies of Liao white-glazed porcelain (fine ware) contain about 33-36% Al₂O₃, 55% SiO₂, and 0.5-1.2% Fe₂O₃ by weight. The proportion of TiO₂ in the bodies of white porcelain from the SJY kiln is extremely low in comparison to its percentage in

pieces from the GWYC kiln sites, namely only about 0.05-0.2% by weight. For this reason, the bodies of SJY white porcelains are whiter than those of the GWYC pieces. The neutral to oxidizing firing atmospheres also created the off-white to creamy tone.

The bodies of Liao white-glazed stoneware (coarse ware) contain about 27-28% Al₂O₃, 63% SiO₂, and 2.3-3.3% Fe₂O₃ by weight. The higher Fe₂O₃ content makes their corpses appear darker in color than those of Liao white-glazed porcelains. The iron-rich bodies with a mottled microstructure were often white-slipped to improve the whiteness of their appearance.

Table 12 The Chemical composition of the bodies of Liao white-glazed stoneware and porcelains⁵²⁷

No.	SiO ₂	Al ₂ O ₃	Fe ₂ O ₃	TiO ₂	CaO	MgO	K ₂ O	Na ₂ O	
LB - A001 (GWY, fine, bowl)	55.35	36.08	1.31	0.94	2.09	0.17	2.90	1.03	Wt%
	66.55	25.55	0.60	0.84	2.69	0.31	2.22	1.20	mol%
LB - A002 (GWY, fine, dish)	56.48	38.02	0.74	0.89	1.76	0.26	0.58	0.53	Wt%
	71.09	23.78	0.34	0.83	2.35	0.49	0.47	0.64	mol%
LB - B002 (GWY, coarse, bowl)	64.47	27.84	2.28	0.86	2.14	0.39	1.44	0.72	Wt%
	74.18	18.87	0.99	0.75	2.68	0.68	1.05	0.79	mol%
LB - C001 (GWY, coarse, bowl)	63.06	27.93	3.10	0.92	2.61	0.26	1.44	0.72	Wt%
	73.18	19.10	1.34	0.79	3.25	0.45	1.06	0.82	mol%
LB - D001 (GWY, coarse, bowl)	62.88	28.89	2.51	0.96	1.53	0.36	1.59	0.65	Wt%
	73.21	19.81	1.11	1.49	1.90	0.63	1.13	0.73	mol%
LB - E001 (SJ, fine, bowl)	54.46	36.57	1.26	0.05	1.55	0.72	3.06	0.49	Wt%
	67.46	25.81	0.55	0.05	1.97	1.26	2.32	0.58	mol%
LB - F (FSD kiln, Liaoning, coarse, bowl)	62.10	28.65	3.26	1.21	0.98	0.61	2.68	0.41	Wt%
	72.93	19.84	1.35	1.07	1.24	1.07	2.03	0.47	mol%
LB - G (CB kiln, Liaoning, coarse, jar)	62.77	28.94	2.28	0.87	2.72	0.25	1.03	0.92	Wt%
	72.87	19.79	0.99	0.75	3.37	0.44	0.77	1.02	mol%
G - 001 (SJ, fine,	67.49	27.58	0.91	0.23	0.98	0.38	1.25	0.50	Wt%

527 Cong Wenyu et al. 1992.

dish)	77.46	18.66	0.38	0.19	1.19	0.65	0.92	0.38	mol%
LB - H001 (HY kiln, Shanxi, fine, dish)	60.84	33.51	0.54	0.60	1.33	0.77	1.82	0.19	Wt%
	71.43	23.16	0.26	0.54	0.02	1.36	1.36	0.02	mol%
LB - Z001 (GT, Cizhou kiln, Hebei, fine)	59.62	34.05	1.30	1.18	0.77	0.44	0.44	1.23	Wt%
	69.43	25.18	0.62	1.11	1.03	0.83	0.90	0.99	mol%
LB - GUAN (Liaoning Provincial Museum, fine, dish with Guan mark)	63.11	33.03	0.64	0.39	0.95	1.05	1.00	0.46	Wt%
	72.73	22.43	0.27	0.34	1.18	1.70	0.72	0.52	mol%

Following Table 13 shows the sintering temperature and physical properties of the bodies of Liao white-glazed stoneware and porcelains.

Table 13 The sintering temperature and physical properties of the bodies of Liao white-glazed stoneware and porcelains⁵²⁸

No.	Sintering temperature (± 20)	Water absorption (%)	Porosity(%)	Thermal expansion coefficient (2×10^{-1})	Vicker's hardness (Kgf/mm ²)	Whiteness (%)
LB - A001 (GWY, fine)	1280	0.15	0.36	5.0	644	65
LB - E001 (SJ, fine)		0.18	0.41		660	
LB - H001 (HY, fine)	1280	0.44	1.04	5.5	644	72
LB - Z001 (GT, Cizhou, fine)	1240	0.46	1.01	5.0	644	
LB - A002 (GWY, fine)	1270	3.32	7.23			67
LB - GUAN (LB, fine, Guan mark)	1260	3.28	7.23	5.9		
LB - B002 (GWY, coarse)	1230	4.90	10.69	5.9	593	
LB - C001 (GWY,	1270	5.48	11.63	5.1	593	

528 Cong Wenyu et al. 1992.

coarse)						
LB - D001 (GWY, coarse)	1200	4.48	9.98	4.7	532	
LB - F (FSD kiln, coarse)	1200	3.35	7.48	5.1		
LB - G (CB kiln, coarse)	1270	3.87	8.35	5.1		

The following Table 14 depicts the chemical composition of Liao white porcelain bodies from the LQW kiln site.⁵²⁹

It is possible to infer from this chart that the content of Fe_2O_3 in the bodies of LQW's Liao white-glazed porcelains is very low, i.e. only about 0.4%, which gives the bodies a very pure, white color.

Table 14 The chemical composition of body of white-glazed porcelain from the LQW kiln site⁵³⁰

No.	Chemical composition (Wt%)											Molecular composition (Al ₂ O ₃ = 1)			
	SiO ₂	Al ₂ O ₃	CaO	MgO	K ₂ O	Na ₂ O	Fe ₂ O ₃	TiO ₂	MnO	P ₂ O ₅	Total	RO	R ₂ O	SiO ₂	R _x O _y
LB8	67.2	25.2	0.3	0.2	3.2	1.3	0.7	1.3	0.01	0.05	99.46	0.04	0.22	4.33	0.08
LB11	53.7	37.9	0.6	0.1	1.3	4.3	0.2	1.4	0.01	0.05	99.45	0.03	0.22	2.4	0.05
LB14	54.1	38.8	0.7	0.2	1	3	0.3	1.4	0.01	0.07	99.58	0.04	0.15	2.36	0.05
LB19	52.4	38.6	0.5	0.3	2	4.1	0.3	1.3	0.01	0.06	99.57	0.04	0.23	2.3	0.05
LB1	53.1	38.3	0.8	0.3	1.9	3.2	0.3	1.4	0.01	0.2	99.5	0.06	0.19	2.35	0.06
LB2	54.9	37.4	1.6	0.1	1.2	2.7	0.2	1.2	0.01	0.2	99.5	0.08	0.16	2.49	0.05
LJB2	54.0	38.6	0.7	0.2	1.1	3.00	0.3	1.5	0.01	0.06	99.46	0.04	0.16	2.37	0.06
LJB4	53.3	39	0.4	0.2	1.2	3.1	0.4	1.7	0.01	0.07	99.38	0.03	0.16	2.32	0.06
DS-1	62.05	31.03	2.16	1.07	1.01	0.75	0.88	0.53	0.04		99.52	0.22	0.08	3.39	0.05
DS-2	65.63	28.22	1	0.7	1.77	0.55	1.04	0.86		0.07	99.84	0.13	0.1	3.94	0.06
DS-3	65.72	27.34	1.51	0.46	2.05	0.23	1	1.07		0.04	99.42	0.14	0.1	4.08	0.07
YN8	69.9	25.1	0.9	1.6	0.91	0.88	0.59	0.24	0.01	0.07	100.18	0.23	0.1	4.73	0.03

⁵²⁹ Chen Yaocheng et al. 1989, 317-321.

⁵³⁰ Chen Yaocheng et al. 1989, 317-321.

YN9	68	27	0.78	1.5	0.91	0.91	0.57	0.34	0.02	0.07	100.1	0.19	0.09	4.27	0.03
Yn11	62.89	32.37	0.66	0.81	1.16	0.94	0.47	0.41	0.02	0.03	99.76	0.1	0.09	3.3	0.03
HG2	63.63	30.54	0.47	0.49	2.02	0.5	1.31	1.21		0.06	100.23	0.07	0.1	3.53	0.08
HG3	66.51	28.12	0.27	0.45	2.28	0.45	1.02	1.31		0.04	100.45	0.06	0.11	4.01	0.08
HG4	53.43	37.16	0.55	0.41	5.05	2.1	0.65	0.8		0.04	100.19	0.06	0.24	2.44	0.04

The table below shows the sintering temperature and physical properties of Liao dynasty white porcelain bodies from the LQW kiln site.⁵³¹

Table 15 The sintering temperature and physical properties of Liao dynasty white porcelain bodies from the LQW kiln site⁵³²

No.	Sintering temperature of bodies(±20)	Burning statement	Porosity (%)	Water absorption (%)	Bulk density (g/cm ³)	Pseudo-specific gravity (g/cm ³)
LB8-coarse		Under burning	6.1	2.85	2.14	2.49
LB9-coarse		Under burning	20.33	11.43	1.78	2.23
LB10-fine	1210	Normal burning	0.26	0.11	2.44	2.44
LB11-fine		Normal burning	0.17	0.07	2.46	2.47
LB12-fine		Normal burning	0.44	0.18	2.39	2.4
LB13-fine	1250	Normal burning	0.19	0.08	2.41	2.41
LB14-fine		Normal burning	0.47	0.2	2.38	2.39
LB15-fine		Normal burning	0.79	0.36	2.36	2.38
LB16-coarse		Under burning	8.47	4.36	1.94	2.12
LB17-fine		Normal burning	0.14	0.06	2.43	2.44
LB18-fine		Normal burning	0.08	0.03	2.5	2.5
LB19-fine		Normal burning	0.76	0.32	2.4	2.42
LB20-fine		Normal burning	0.68	0.29	2.36	2.37
LB21-coarse		Under burning	9.87	4.69	2.11	2.34
LB22-fine		Normal burning	0.38	0.16	2.32	2.32
LB23-fine		Normal burning	0.41	0.17	2.36	2.37
LB24-coarse		Normal burning	0.83	0.35	2.35	2.37
LB25-coarse		Normal burning	0.74	0.32	2.33	2.35

531 Chen Yaocheng et al. 1989, 317-321.

532 Chen Yaocheng et al. 1989, 317-321.

LJB1-fine		Normal burning	0.53	0.22	2.41	2.42
LJB2-fine		Normal burning	0.17	0.07	2.42	2.43
LJB3-fine		Normal burning	0.16	0.07	2.4	2.4
LJB4-coarse		Under burning	6.58	3.21	2.05	2.19
LB1-fine		Normal burning	0.25	0.1	2.48	2.48
LB2-fine	1240	Normal burning	0.74	0.3	2.42	2.44

5.2. SLIPPING

White slip was applied in order to 'improve' the appearance of the clay, as well as to create an appropriate background for painted and carved decorations or colorful glazes. In Liao ceramics, these adornments can most often be found on lead-glazed earthenware and lower grades of white-glazed stoneware. Similar to the raw materials observed in Liao low-grade white stoneware clays, Liao white slips show a mineralogy consisting of pyrophyllite (Yelashi, 叶腊石 in Chinese) and kaolin, as well as of a small amount of mica⁵³³. The powdered clays were blended with water in order to obtain a liquid slip.

Table 16 in the following presents the chemical composition of slips on Liao three-color lead-glazed ceramics from the GWYC kiln site.

Table 16 The chemical composition of slips on Liao three-color lead-glazed ceramics from the GWYC kiln site⁵³⁴

No.	SiO ₂	Al ₂ O ₃	Fe ₂ O ₃	TiO ₂	CaO	MgO	K ₂ O	Na ₂ O	Loss in firing
Slip2#	55.98	31.35	1.33	1.18	2.74	0.77	1.78	1.49	2.95
Slip 4#	48.95	34.71	1.13	0.93	1.91	1.60	0.60	1.12	3.76

In the production of Liao ceramics, the process of slipping begins after the forming of the bodies.

For slipped white glaze stonewares, the procedure intended that the formed bodies were dipped in white kaolinitic slips before firing and later decorated by carving or black-painted designs underneath slightly dull but clear glazes. The slipped and glazed bodies were once high-fired in the kiln.

⁵³³ Guan Baocong & Ye Shuqing 1985, 38.

⁵³⁴ Guan Baocong & Ye Shuqing 1985, 38.

In the case of lead-glazed earthenwares, the formed but unfired ceramic bodies were dipped in white kaolinitic slips. Subsequently, a bout of high-firing turned the bodies into biscuits which were then decorated with lead glazes of various colors according to their intended function. Eventually, the glazed biscuits were low-fired in the glaze kiln. The ground of pale slips illuminated the lead glazes.

The slip on Liao ceramics often expires short off the vessels' feet. While the majority of slips were applied underneath the glaze, cases occur in which an unfinished glaze layer exposes small parts of the slip. The latter generally has a pale and lackluster appearance and amounts to a gauge of 0.02~0.20 mm.

5.3. GLAZING AND THE RAW MATERIALS OF GLAZES

Apart from its practical protective function, glaze also possesses an aesthetic quality which is due to its various colors. As different ways of glazing give rise to disparate ornamental effects, it is not only one other procedure in the process of ceramic production, but rather constitutes a proper ornamental technique.

Typically, Liao glazed stonewares were oxidized (black, brown, off-white, or teedust-green), and the layer of glazes often stops some way short off their feet, revealing the pale stoneware clays underneath. As such, this particular method of glazing was the survival of practice of the 6th-century, when unstable lime glazes had easily slipped downward during firing, and an appropriate gap had been left uncoated at the lower part of the vessel to minimize sticking. Partial glazing also occurs on Liao lead-glazed earthenwares, likewise preventing the rather fluid lead glazes from spilling over the vessels' bases. Liao porcelains, by contrast, are mostly fully glazed (apart from their foot-rings), a process that was assisted by the high viscosities of their clay-rich glazes.

It appears that glazes were also applied to function as sealing agents against water. Following the forming of the clay and slipping of the surface (if necessary), the bodies of monochrome-glazed ceramics were repeatedly dipped into the liquid glaze with the sides leaning in order to finish the coating process. Where three-color glazed earthenwares are concerned, the use of glazes for decorative purposes was particularly well-handled by Liao potters. Dotted, dripping, brushing, applying wax-resist, etc. were all methods experimented with, procuring a rich array of patterns and styles. Generally following the forming of the clay and slipping of the body surface was the employment of yellow, green, and sometimes white glazes to cover appropriate molded designs on a vessel. However, the procedure was often only cursorily performed.

Different glazes consist of different chemical compositions. Based on results tested by other scientists, this fact will be illustrated in the following using the examples of Liao white wares, as well as lead-glazed and borax glazed earthenwares.

5.3.1. White Stoneware and Porcelains

The following Table 17 shows the chemical composition of the glazes applied to Liao white-glazed stoneware and porcelains.

According to this data the glazes of Liao white-glazed stonewares and porcelains in average contain about 5% CaO, 1.4% MgO, 1% Fe₂O₃ and 0.2% TiO₂ by weight, thus belonging to the system of lime-alkali glazes and to the lime-magnesia style. The transparent vitreous glazes contain fewer crystals. The glaze layer is very thin, amounting to a gauge of about 0.06 mm to 0.16 mm. In the main, the glazes appear in a pure white color with the hint of a grayish tinge. The latter is caused by the low levels of iron titanium (TiO₂) and the weak reduction firing atmosphere. Analogous to the clays of other northern white-glazed stonewares and porcelains, the ones of Liao white wares show a relatively high proportion of titanium (TiO₂). The yellowing or graying effects of this oxide necessitated the application of colorless glazes; the problem was thus solved by the use of low-titanium (TiO₂) raw materials in the glaze recipes. The percentages of iron and titanium (TiO₂) in the glazes of white wares from the GWYC kiln are higher than those found in the SJY and HYY kilns' products, explaining the obvious grayish tones of GWYC glazes.

Table 17 The chemical composition of the glazes of Liao white-glazed stonewares and porcelains⁵³⁵

No.	SiO ₂	Al ₂ O ₃	Fe ₂ O ₃	TiO ₂	CaO	MgO	K ₂ O	Na ₂ O	MnO	
LB - A001	68.14	15.24	.092	0.33	6.77	1.41	3.60	0.99		Wt%
	76.46	8.75	0.38	0.26	8.14	2.35	2.57	1.07		mol%
LB - B001	70.81	13.44	0.70	0.28	6.49	1.65	4.12	1.05		Wt%
	77.72	7.38	0.33	0.23	7.63	2.69	2.87	1.12		mol%
LB - B002	69.74	12.96	0.93	0.25	8.55	1.32	3.30	1.16		Wt%
	76.54	7.12	0.38	0.20	10.05	2.16	2.32	1.23		mol%
LB - E001	69.35	18.21	1.10	0.14	3.75	1.16	4.63	0.85	0.09	Wt%
	78.34	10.31	0.46	0.12	4.54	1.96	3.33	0.93		mol%
LB - G	64.87	15.14	1.61	0.33	4.10	1.44	4.12	1.17	0.13	Wt%

535 Cong Wenyu et al. 1992.

	77.59	9.06	0.71	0.29	5.26	2.56	3.14	1.36		mol%
LB - Z001	65.10	22.13	1.20	0.50	4.22	1.20	2.17	0.48	0.11	Wt%
	75.48	12.85	0.52	0.44	5.24	2.07	2.05	0.53		mol%
LB - GUAN	66.76	15.19	1.00	0.10	2.96	2.64	1.88	0.58		Wt%
	79.45	9.47	0.44	0.08	3.77	4.67	1.42	0.67		mol%

The following Table 18 displays the chemical composition of Liao white-glazed porcelains from the LQW kiln sites.

According to the previous chart, the glazes of Liao white-glazed stonewares and porcelains from the LQW kiln sites contain a significant amount of magnesia (MgO), i.e. approximately 6% by weight in average, and therefore belong to the system of lime-alkali glazes and to the lime-magnesia style. Analogous to those of other northern porcelains and stonewares, the bodies of LQW white wares were often extremely high-fired, necessitating new approaches to glaze construction in order to achieve a matching refractoriness. The use of high temperature glaze-flux magnesia (MgO), which reduced the total flux contents of the glazes, substantially solved this problem of LQW white wares. Extra levels of sophistication are also evident in these analyses, most notably in the high-silica contents of the glazes, which reinforced the craze-control afforded by magnesia. Another feature of LQW white glazes is their general RO: R2O ratio, which approaches 1:1.

Table 18 The chemical composition of Liao white-glazed porcelain of the LQW kiln sites⁵³⁶

No.	Chemical composition (Wt%)											Molecular composition (RO+R2O = 1)				
	SiO ₂	Al ₂ O ₃	CaO	MgO	K ₂ O	Na ₂ O	Fe ₂ O ₃	TiO ₂	MnO	P ₂ O ₅	Total	RO	R ₂ O	Al ₂ O ₃	SiO ₂	R ₂ O _y
LB8	60	13.9	14.6	5.3	2.4	1.2	1.2	0.3	0.13	0.5	99.53	0.9	0.1	0.31	2.3	0.04
LB11	67.6	14.2	7.8	4	1.3	3.1	0.8	0.1	0.12	0.3	99.43	0.79	0.21	0.46	3.73	0.03
LB14	70.1	15.2	4.6	3.4	3.1	1.8	0.9	0.2	0.1	0.2	99.6	0.73	0.27	0.65	5.12	0.05
LB19	72.6	16.9	0.8	0.5	3.1	4.8	0.3	0.3	0.3	0.05	99.38	0.19	0.81	1.22	8.88	0.04
LB1	73.1	14.2	1	2.7	2.6	4.8	0.8	0.1	0.03	0.2	99.53	0.45	0.55	0.73	6.41	0.04
LB2	69.6	13.3	7	3.1	1.2	3.8	1	0.1	0.09	0.4	99.59	0.73	0.27	0.47	4.2	0.04
LJB2	72.3	17.4	1.5	1.2	1.7	4.3	0.4	0.4	0.04	0.3	99.54	0.4	0.6	1.19	8.35	0.08

⁵³⁶ Chen Yaocheng et al. 1989, 317-321.

LJB4	72.7	17.7	1.1	1.5	1.5	4.1	0.4	0.4	0.04	0.08	99.52	0.41	0.59	1.25	8.71	0.07
DS-1	72.14	17.52	3.92	2.32	1.97	0.48	0.75	0.19	0.03	0.32	99.64	0.82	0.18	1.10	7.65	0.06
DS-2	68.9	20.02	3.77	2.09	2.4	0.36	1.06				99.6	0.79	0.21	1.31	7.65	0.05
DS-3	70.6	18.5	3.79	2.06	2.43	0.28	0.97				99.63	0.79	0.21	1.21	7.83	0.04
YN4	63.02	13.46	16.58	3.38	1.26	0.39	0.79	0.18	0.08	0.72	99.86	0.95	0.05	0.33	2.63	0.03
YN6	71	16.9	2.7	0.7	6.4	1.4	0.4	0.2	0.04	0.3	100.04	0.42	0.58	1.06	7.5	0.06
YN9	67.46	19.51	6.8	2.92	0.61	1.5	1	0.13	0.06	0.52	100.51	0.87	0.13	0.86	5.04	0.06
HG1	64.65	13.9	12.29	1.89	2.97	2.17	0.84	0.16			98.89	0.8	0.20	0.41	3.23	0.02
HG2	67.66	15.87	1.85	1.53	2.43	0.78	0.87	0.43			100.42	0.86	0.14	0.58	4.17	0.04
HG7	69.99	17.04	3.3	4.14	2.86	2.97	0.47	0.33	0.12		101.04	0.68	0.32	0.7	4.92	0.04

5.3.2. Lead Glazes

Liao lead-glazed earthenware, especially three-color lead-glazed wares, borrowed many forms and glazes from the tradition of Tang three-color glazed earthenware. Three of the colors used for lead-glazed wares - copper-green, iron-brown, and transparent glaze - had already seen use in burial wares of the Eastern Han period and the Tang dynasty. Tang potters added a cobalt-blue glaze and two types of black to the existing palette. The popular name for lead-glazed earthenware during the Tang dynasty, sancai (meaning 'three-colored' ware), therefore underestimated the full range of colors applied to these products. However, it does describe the most typical Tang dynasty lead glazes, namely straw, amber, and green. Potters of the Liao dynasty also created a number of very distinguished three-color lead-glazed earthenwares of their own, making imaginative use of uncolored cream-white areas as well as of complexly molded decorations in the style of silverware.

In terms of composition, the analyzed lead glazes of the Liao dynasty appear to be analogous to those used on three-color glazed earthenwares of the Tang dynasty. Like the Tang originals, the Liao glazes belong into the general area of the 650 lead oxide-silica-alumina eutectic mixture.

In the following, Table 19 depicts the chemical composition of the glazes of Liao three-color-glazed earthenware.

Table 19 The chemical composition of the glazes of Liao three-colored earthenware⁵³⁷

No		SiO ₂	Al ₂ O ₃	PbO	Fe ₂ O ₃	TiO ₂	CaO	MgO	K ₂ O	Na ₂ O	MnO	NiO	CuO	CoO	SnO	Total
1	LSC-2# White	42.56	10.59	43.31	0.43	0.10	0.96	0.11	0.01	0.46	0.01	0.41	0.06	0.09		
2	LSC-2# Green	33.28	3.45	57.22	1.48	0.05	0.93	0.12	0.49	0.24	0.01	0.14	2.09			
3	LSC-4# Green	35.87	7.42	45.91	0.75	0.01	0.51	0.08	0.47	0.22	0.01	0.02	1.39		7.48	
4	Green	32.3	3.4	54.8	1.5		0.9		0.5	0.2	0.1		2.1			
5	Green	33.6	3.4	57.2	1.5	0.05	0.9	0.1	0.5	0.2	0.01	0.14	2.1			99.4
6	Green	35.9	7.4	45.9 5	0.7	0.01	0.5	0.1	0.5	0.2	0.01	0.02	1.4			92.7
7	Green	34.6	8.2	50.2	1.3		1.0	0.2	1.1	1.1	0.03		1.8			99.5
8	Green	33.2	4.4	56.7	0.5		0.9	0.3	1.0	0.8	0.03		1.9			99.4
9	LSC-3# Yellow	33.03	6.58	53.67	3.53	0.05	1.01	0.14	0.67	0.39	0.01	0.09	0.06			
10	LSC-5# Yellow	33.56	7.07	52.71	4.03	0.04	1.10	0.08	0.39	0.27	0.02	0.07	0.20			
11	Amber	33.0	6.6	53.7	3.5	0.05	1.0	0.1	0.7	0.4	0.01	0.1	0.06			99.2
12	Amber	33.6	7.1	52.7	4.0	0.04	1.1	0.1	0.4	0.3	0.02	0.07	0.2			99.6
13	Eutectic mixture	31.7	7.1	61.2												100

The following Table 20 shows the spectrum analysis of Liao lead glazes of the GWT kiln site.

Table 20 The spectrum analysis of Liao lead glazes of the GWT kiln site⁵³⁸

No.	Quantity			Main coloring elements
	Large	Small	Micro	
LSC-2# White glaze	Al, Si, Pb	Ca, Fe	Ti, Ni, Mg, Na, K, Mn, Sb, Bi, Sn, Ga, B, Zr, Cr, Sr, Ba, Cn, Ag	

⁵³⁷ Anon. 1988, 127, table 7-5; Chen Yaocheng et al. 1989, 322, table 2; Guan Baocong & Ye Shuqing 1985, 38.

⁵³⁸ Guan Baocong & Ye Shuqing 1985, 38.

LSC-2# Green glaze	Si, Pb	Al, Fe, Cu	Ti, Ni, Mg, K, Na, Mn, Sb, As, Co, Sr, Ba, Zr, Bi, Sn, Ga, B, Mo, Ca, Ag, V, Cr	Cu ⁺⁺
LSC-3# Yellow-glazed	Al, Si, Pb	Fe, Ca	Ti, Ni, Na, Mg, K, Mn, Sb, Sr, Ba, Bi, Sn, Ga, Cu, Ag, V, Zr, Cr	Fe ⁺⁺⁺
LSC-4# Green glaze	Al, Si, Pb	Fe, Ca, Sn, Cu	Ti, Mg, Ni, Mn, Sb, Na, Bi, B, V, Ag, Zr, Cr, Sr, Ba	Cu ⁺⁺
LSC-5# Yellow glaze	Al, Si, Pb	Ca, Fe	Ti, Ni, Mg, K, Na, Mn, Sb, Sn, Bi, Ga, Cu, Ag, Zr, Cr, Ba, Sr, Co	Fe ⁺⁺⁺

Liao lead glazes belong to the PbO-SiO₂-Al₂O₃ system of low-fired glazes, which contain approximately 50% PbO and over 30% SiO₂. The main coloring element of the green glaze is Cu⁺⁺, the CuO level of which is roughly 2%. The principal coloring element of yellow glaze is Fe⁺⁺⁺ with a Fe₂O₃ level of approximately 4%.

A few minor differences between Tang and Liao dynasty lead glazes can be observed, mainly in the ways in which coloring oxides are used. The first glaze listed in Table 19 is unusual in being colored by a nickel-cobalt mineral, rather than by the iron- and iron-copper-cobalt typical of the Tang dynasty's lead glaze. Liao dynasty's green lead glazes tend to be richer in iron oxide and lower in copper oxide than their Tang counterparts, supplying them with more of a yellow-green tone. However, yellow and amber lead glazes of the Liao dynasty, are quite similar to the Tang versions. It has been proposed that Liao dynasty three-colored earthenware underwent a hard biscuit-firing at about 1,120 °C, and that akin to Tang wares their body materials were essentially underfired stonewares. It is probable that Liao dynasty glazes would have matured at a temperature of around 1,000 °C.⁵³⁹

There is evidence, if only sparse, of the use of cobalt oxide in Chinese glazes during the Liao dynasty. For example, in northern China a very impure nickel-cobalt ore was reported for a Liao dynasty three-color lead glaze. This discovery is remarkable because of the extreme rarity of blue lead glazes of that period.⁵⁴⁰ It suggests that the traditional types of cobalt ore used in the Tang dynasty ceramics of northern China may not have been available to potters of the Liao dynasty.⁵⁴¹

5.3.3. Borax Glazes

⁵³⁹ Guan Baocong & Ye Shuqing 1985, 38.

⁵⁴⁰ Anonymous 1988, 127, table 7-5.

⁵⁴¹ Chen Yaocheng et al. 1995, 208.

All the low-fired Chinese glazes described in this volume so far have been either of the high-lead or lead-baria type, and displayed broadly similar compositions. However, an important exception to this pattern was discovered at the LQW kiln-area in Beijing. Two LQW shards from the Liao dynasty, displaying unusual dark-green earthenware glazes, were analyzed in 1989 and shown to contain boric oxide as their major glaze-flux. Their lead oxide contents were negligible, making them the earliest boric oxide-fluxed glazes ever found worldwide.⁵⁴²

Boric oxide (B_2O_3) is a versatile glaze material that can operate variously as a flux, a glass former, and a glaze stabilizer. In large quantities it may cause crazing, while in smaller amounts it tends to reduce crazing, constituting the so-called 'boric oxide anomaly'.⁵⁴³ Its refractive index is lower than that of lead oxide, which explains why boric oxide glazes tend to lack the richness of their lead equivalents. Their response to coloring oxides resides midway between alkaline glazes and lead glazes. For instance, when copper oxide is used in boric oxide glazes it causes a greenish-blue color, rather than the turquoise-blue of high-alkali glazes, or the strong emerald-greens typical of glazes that are rich in lead.

The following Table 21 shows the chemical composition of the glazes on Liao borax-glazed earthenware from the LQW kiln site.

These glaze analyses from LQW are difficult to interpret in terms of both their chemistries and their original recipes. No eutectic basis is apparent in the glazes, and it is hard to identify any natural raw materials which may have been used in their composition.

Table 21 The chemical composition of the glazes on Liao borax-glazed earthenware from the LQW kiln site⁵⁴⁴

No.	SiO ₂	Al ₂ O ₃	Fe ₂ O ₃	CaO	MgO	K ₂ O	Na ₂ O	PbO	B ₂ O ₃	CuO	MnO	P ₂ O ₅	Total
Liao borax dark-green glaze 1	58.1	9.3	0.8	4.6	0.6	3.1	5.1	1.3	10.3	6.4	0.04		99.6
Liao borax dark-green	54.7	5.5	0.6	6.2	2.0	1.5	10.5	0.4	12.8	6.3		0.2	100.7

⁵⁴² Chen Yaocheng et al. 1989, 317-21.

⁵⁴³ Singer & Singer 1963, 208-11. The anomaly occurs when boron-oxygen bonds change from threefold to fourfold co-ordination.

⁵⁴⁴ Chen Yaocheng et al. 1989, 317-321.

glaze 2													
---------	--	--	--	--	--	--	--	--	--	--	--	--	--

A possible source of the boric oxide contained in these glazes may be ulexite ($\text{Na}_2\text{O} \cdot 2\text{CaO} \cdot 5\text{B}_2\text{O}_3 \cdot 16\text{H}_2\text{O}$), a material not only rich in boric oxide, but also in soda and calcia, thus comprising the three main fluxes observed in above analyses. Glaze 1 may have been attained by a mixture of a typical ulexite material 28.5, feldspar 46.5, quartz 18.5, and copper oxide 5.5. Unfortunately, these raw materials do not comply with Glaze 2 which is too rich in sodium oxide and too poor in alumina to have come by the use of ulexite alone. However, it may be reconstructed by a combination of ulexite 32, soda ash 14, quartz 37, China clay 11, and copper oxide 5, or alternatively by compounding raw borax 35, soda ash 9.5, quartz 31, clay 9, and copper oxide 6. In brief, Glaze 2 can only be obtained by the use of soluble raw materials, a fact which suggests that some of the original Liao boric oxide glazes may have been fritted. Further oddities of these glazes are the high percentages of cupric oxide (av. 6% CuO) contained in them, amounting to about three times as much as the total proportion of copper found in typical green lead glazes of the Liao dynasty.⁵⁴⁵

*Despite the importance of these glazes in the history of world ceramics, and their great rarity in China itself, their appearance was actually rather undistinguished, and boric oxide glazes do not seem to have been developed further at this time. The Chinese researchers who studied the glazes suggest that the huge demand for glazed tiles for temples and palaces in Peking may have stimulated experiment with these new earthenware compositions, and they propose borax as the most likely source of B_2O_3 .*⁵⁴⁶

5.4. LOADING (STACKING) METHODS AND KILN INSTRUMENTS

For potters, the main aims in loading and setting ceramic kilns are the production of sound wares, the encouragement of even firings, and the economical use of fuel. Liao potters developed their own special methods of loading their products into the kilns prior to firing.

Even though no fully stacked Liao kiln has ever been discovered, it is possible to deduce clues about loading methods from the ceramics themselves. For instance, it can be observed that a multitude of clay instruments were employed to prevent wares from sticking together when their glazes melted during the firing process. In many cases these small clay separators remained fused in the vessels' rims, or less often in their bases. Some types of Liao white-glazed stonewares, such as round bowls and dishes,

545 Wood 1999, 207-9.

546 Chen Yaocheng et al. 1989, 317.

were commonly loaded in stacks supported and separated by clay spurs. As a result of this method, three or four crude scars frequently remained on their bases (**Pl. 5, Pl. 18-Pl. 20, Pl. 66, Pl. 68**). Several low-fired lead-glazed earthenwares, like oblong-lobed dishes and round dishes, were stacked into the kiln separated by triangular setters which left three small scars on their rims or bases. Bobbin-shaped support instruments were employed to isolate chicken-leg vases and left big, crude scars on surface of their belly (**Cat. 553, Cat. 554**). Furthermore, the flow of the glazes provides information on the direction of loading of ceramic wares. Seeing as the glaze on the majority of Liao vessel flowed downward from the mouth rim to the bottom, it can be established that they stood in an upright position during the firing process. In fewer cases, an upside-down loading method can be inferred from an opposite flow of the glaze from the bottom to the mouth rim (**Fig. 4**).

Of all Chinese glazed ware, it was low-fired lead-glazed earthenwares which were the easiest to load and fire. They were toughened by a prior bout of biscuit-firing and shrank no further when reheated at glazing temperature. Liao lead-glazed dishes often bear three small scars which were inflicted by the points of triangular setters (**Fig. 4**) and indicate a loading method by which the vessels were stacked on top of each other and merely isolated by reusable clay props.

Liao high-fired stonewares and porcelains, by contrast, must have proved far more difficult to pack and fire safely. In spite of the fact that they were made from virtually the same clay as earthenwares, they had higher firing shrinkages and showed a tendency toward distortion.

They were open-fired in cool-burning kilns of the mantou style. The stacks of bowls were separated by four clay spurs and the bases of the wares remained unglazed. While the four supports with the four raised points of the setters rested on the glazed insides of the bowls, the contact marks could be chipped clean after firing. In Liao kilns, simple thrown columns were also employed to support stacks of bowls, sometimes with the bowls loaded in an upright position, sometimes facing upside-down (**Fig. 19, Fig. 20**). The latter arrangement may have provided better protection from wood ash, roof debris, and fragments of exploded wares.

Due to their shrinkage in high-temperature production, it is likely that the triangular setters, placed between bowls and dishes to secure them and to keep their feet round and rims true, were only single-use pads. Notably, the column-and-parting pad loading system of Liao kilns was influenced by other contemporary kilns of northern China, which in turn had already been used in southern China, but with round rather than with triangular supports. It appears that the respective use of triangular and round supports

reflects the familiar north-south divide of China. The adoption of triangular setters by Liao kilns apparently resulted from the radiation of ceramic production areas in central Hebei province. As the (**Map 16**) shows, two styles of triangular setters were used, one equipped with points on one side only, the other having them on both sides. The double-sided triangular setter resembled the highest stage of development of the triangular cake, which typically left three small pin marks on both the bottom and inner bottom surface of the ware.

At the Liao SJY and GWYC kiln sites, a kind of L-shaped step setter was employed for securing wares in the kilns (**Pl. 22**). These heavy, L-sectioned rings, apparently influenced by the Xing and Ding kilns of northern China, appear to have functioned doubly as both saggars and setters.

The most original and economical development for firing bowls and dishes which was ever devised in northern China, was the step setter which appeared at Ding kilns during the Northern Song dynasty. This tool was essentially a thick bowl, the inside surface of which was ridged with a series of fine steps. A restricted number of bowls of increasing diameter could be set rim-down on these ledges before both the setter and the bowls were placed within heavier fireclay saggars. Step setters, which were made from clays similar to the ones of the wares they supported, were used only once. Like the bowls, they shrank during firing, thus keeping the vessels' rims round and their forms true. In order for the method to work successfully, the rims of the bowls and dishes needed to be left unglazed, a flaw often disguised after firing by the fitting of deep metal bands.

It is possible to see the origin of this particular upside-down loading method in the Xing kilns, where an early type of rim-down setting technique had been devised which used saggars with L-shaped cross-sections for firing bowls. Much finer ring setters, made from porcelain clay, were developed at the Ding kilns. They were intended for single use only, and placed within much heavier, reusable saggars. The latter allowed as many as twenty identical bowls or dishes to be fired while stacked upside-down and on top of each other. The most sophisticated upside-down firing method applied at the Ding kilns made use of surmounted, bowl-shaped, stepped setters with stacks of supporting rings. Once assembled, the outsides of the setter-and-bowl stacks were lightly brushed with slip to serve as a temporary bond, and placed inside heavy fireclay saggars. This arrangement resulted in a quite remarkable setting density within the kilns. The upside-down method of packing saggars spread from the Ding kilns to a number of northern Cizhou kilns as well as to Liao kilns like GWYC and SJY in Inner Mongolia.

Furthermore, it traveled south to Jingdezhen and to kilns in Fujian province in the southern Song dynasty (**Map 17**).⁵⁴⁷

In Liao kilns, such as the GWYC, SJY, and LQW sites, another important kind of kiln instrument was used, namely saggars. These particular tools take the form of clay boxes (cylindrical, bowl-shaped, or M-shaped) into which raw or biscuit wares were packed. The loaded boxes were subsequently assembled into tall columns or 'bungs' within the kilns (**Fig. 3, Fig. 7, Fig. 16**). Saggars have proved to be one of the greatest boons to ceramic production which solve an entire range of problems at once, for instance protecting wares from coal or wood ashes, containing the destructive impact of exploding wares, shielding them from cooling draughts, encouraging an even distribution of heat in the kiln (both through their mass and the uniformity of stacking they allow), allowing a more thorough filling of the kiln space by avoiding the use of unstable stacks, and allowing taller kiln-chambers to be built and exploited. The tools have been shown to date extremely far back in ancient ceramic history, at least to the late 3rd millennium B.C., when 'bungs' of thrown saggars were used by the Indus civilization of northern India for firing bangles.⁵⁴⁸ In China, their first identifiable employment occurs more than 2,500 years later.⁵⁴⁹ Liao saggars were mainly bowl-shaped or cylindrical (**Fig. 16**).

5.5. FIRING AND KILNS

The main objective of firing ceramics is the removal of water from the material. At the heart of the subject lies the unique ceramic effect of 'transformation', whereby the clay body is converted either into earthenware, stoneware, or porcelain by substantial inputs of energy.

Water in dry clay exists in three states: mechanically combined water, adsorbed water, and chemically combined water. Once a pot has been formed, the 'water of plasticity' is redundant. It is allowed to evaporate gradually, usually by placing the newly made wares on racks inside the workshop. Importantly, drying is always associated with shrinkage. Positive heat may be applied at the last stage of drying, that is when shrinkage is complete, for instance by placing the wares into a sunny spot. Once the

547 Liu Xinyuan 1980, 53-5.

548 Vidale 1990, 240-6.

549 Some Chinese reports show that saggars have been associated with the production of fine Long-shan Neolithic 'eggshell' wares in Shandong province, but the claim remains to be confirmed. The earliest saggars from excavations cited up to now date to the early +4th century.

wares are dry to the touch they can be placed in the kiln, then the chamber's door is bricked and sealed and the firing started.

5.5.1. The Firing Process

The first stage passed of the firing process essentially constitutes the continuation and conclusion of drying. The first 200 °C of firing are therefore a dangerous period for the wares, which must be slowly and carefully negotiated. While a firing rate of about 30 °C/hour might be used for small or thin objects, 10 °C/hour or less may be necessary for thicker and heavier wares. Once the overall temperature of the kiln reaches roughly 200 °C, the first two types of water mentioned before will have been eliminated from the clay, and the rate of the temperature rise can be increased to approximately 100-150 °C/hr. The first stage of firing is often aptly referred to as 'water smoking'. It is also during this period that water absorbed from the ground and the atmosphere vaporizes and that steam needs to be liberated from the kiln's structure.

The second stage of firing (c. 200-350 °C) involves the charring (though not the burning) of the organic material contained in the clays. Organic substances are abundant in sedimentary Liao ceramics.

At 573 °C, the quartz sand which is present in all clays to a greater or lesser extent undergoes a 2% volumetric expansion as the atomic bonds within the SiO₂ molecule are straightening. This process is known as the α - β quartz inversion, and it is reversible (β - α) by cooling. It occurs in the middle of a change central to the firing procedure, i.e. the conversion of clay to ceramic. Once dehydroxylation has taken place, an entirely new mineral, 'metakaolin', has formed.

Therefore, true-fired pottery can be created at 650 °C; yet, kiln firings rarely terminate at this temperature because the fired material is mechanically very weak and prone to cracking during cooling, especially when the wares pass through the β - α quartz transition. The only strength present in the clay at this stage is derived from solid-state sintering. Sintering is both the simplest and the weakest way to attain ceramic strength.⁵⁵⁰

550 A detailed account of 'dry' sintering may be found in Singer & Singer 1963, 171-73. The process of 'wet' sintering (sintering with a reactive liquid) is explained in Kingery 1960, 386-89. Kingery notes: 'Here we are referring to systems where the solid phase shows a certain limited solubility in the liquid temperature; the essential part of the sintering process is the solution and reprecipitation of solids to give increased grain size and density.' Ibid., 386.

As the firing progresses to 800 °C and above, carbonaceous materials begin to burn properly and sulfur dioxide, chlorine, and fluorine may then also be liberated from the clay if the kiln's atmosphere is suitably oxidizing. In the case of sedimentary clays, which are rich in organic substances and provide the material for Liao ceramics and other northern Chinese stonewares and porcelains, these gases can sometimes be sensed around the kiln in the form of choking fumes. Small amounts of body-glass may begin to form in the wares at this stage, mainly on account of the combination of fine silica particles with potassium and sodium ions present in the clay bodies. These components supplement the otherwise low strength afforded by sintering, and provide some glassy 'glue' between the bodies' mineral-grains.

As the kiln-temperature rises further (to approximately 980-1,100 °C), the development of body-glass accelerates, assisted by some further changes in the metakaolin particles which convert to spinel. The mineral particles thus bond more firmly and improve the fired strength of the wares, an effect which can be enhanced by continued sintering. Temperatures of about 1,000 °C were often used for biscuit-firing of Liao lead-glazed earthenware. It provided the vessels with sufficient strength to stand the stresses of cooling and the subsequent handling during glazing, but still left them porous enough to allow glaze suspensions to dry rapidly on the biscuit. The average firing temperature of Liao lead-glazed earthenware was roughly 1,120 °C.

At a temperature of 1,100 °C or higher, a further change occurs in the fired clay material as the spinel converts to mullite. More secondary silica is freed by this reaction, which boosts the levels of body-glass, needle-shaped mullite. These new, fibrous crystals have strong reinforcing effects on fired clays, and greatly enhance the ceramic strengths previously developed in sintering and supplement the development of body-glass. The longer the kiln-firings continue at over 1,100 °C, the larger and longer the mullite crystals grow, and the stronger the wares become. The presence or absence of mullite in fired clay establishes the clearest differences between earthenware and high-fired materials like stoneware and porcelains. A final feature of the high-temperature stage in firing is the thermal creation of a new form of silica: β -cristobolite. The material has a profound effect on the glaze-fit. As glazes are solid by this stage, the 'cristobolite squeeze' tends to compress the glaze-coat. Long firings at high temperature can also cause good reaction-zones to develop between glazes and bodies. The average firing temperature of Liao stoneware and porcelains ranged at about 1,270 °C.

The final stage of firing stipulated an extended period of soaking at full temperature in order to ensure a proper glaze maturity and to even the temperatures within the kilns. It was known as the 'black fire', as it was particularly used for black glazes. However, in

spite of this precaution, temperature differences of some 100 °C were still common in Liao coal-fired mantou kilns.

During the firing process, most of Liao ceramics were burnt under oxidized atmospheres in the kilns, partly explaining the warm or creamy tones showing on some Liao white stonewares. As for many dark-glazed Liao ceramics, such as black-glazed and teedust-green-glazed wares, oxidized firings were even more substantial. Some Liao white-glazed porcelains were fired under weak reduction atmospheres, for instance a proportion of the SJY and LQW kilns' fine-fired wares. These white-glazed porcelains accordingly displayed slightly cold tones.

5.5.2. Fuel

Several Liao kilns, among them the LQW, GWYC, GGT, and HYY kiln sites, used coal as their primary firing fuel. In areas which lacked coal resources and in the early period of Liao in general, wood represented the capital fuel. Both of these burning materials also provided the major fuels in the production of historical Chinese ceramics. The most obvious difference between the floor plans of wood- and coal-fired kilns can be observed in the area of the firebox. While the fireboxes of wood-burning kilns spanned the chambers' entire widths, coal-burning examples only occupy the central third of this area. The liberated space in the grate area of coal-burning kilns could be used to set extra columns of saggars in. At LQW kiln sites, both structures were discovered (**Fig. 12**, **Fig. 13**).

A kind of fuel little used in China, but widely employed in the rest of the world, is herbivore dung. Dung as a firing material for ceramics tends to be associated with pastoral cultures and with a shortage of wood. A number of Liao kilns located in the Inner Mongolian grassland, which lacks wood and coal resources and was populated by nomadic people, might thus have made use of herbivore dung for firing. However, limited archaeological evidences forbid to take this hypothesis as proven.

5.5.3. Kiln

Concerning kiln structures, most of the Liao kilns were hemispherical mantou kilns, a traditional northern Chinese type, which was named after its shape reminiscent of a steamed bun. The earliest mantou kilns, derived from the primitive cave kilns, were built in the China of the early Shang period (ca. 16th-11th century B.C.). Structures developed into semi-down-draft kilns in the Tang dynasty (618-907 AD), and matured in the Song dynasty (960-1127 AD).

Liao mantou kilns were influenced by some northern Chinese kilns of the Song dynasty, and generally shaped in cubic firing chambers with domed roofs, deep ash-pits in the

front, and two short, wide chimneys set side-by-side at the rear (**Fig. 12, Fig. 13**). Kiln chimneys have two prime functions: firstly, to carry smoke out of the kiln area, and secondly to sustain and control the kiln's draft. In practice, two chimneys set side-by-side help avoid building problems associated with the technique of conjoining separate exit flues into a single flue which is then supposed to be lead into a singular central chimney. Two chimneys can be used to balance reducing atmospheres within a kiln's chamber, and permit a better control of the right- and left-hand sides of the setting. Fire-holes were often left in the kilns' main doors, which were bricked up after the wares were loaded on the interior. Fuel was thrown through these stoke-holes onto the fan-shaped grates inside the kiln. More holes at a lower level, for instance beneath the fire bars, admitted the air necessary to burn the fuel.

The majority of Liao kilns were built from bricks and coated with coarse sand. Judging from published drawings of LQW kiln sites, the brick walls of these kilns were single course and rather thin, that is approximately 16 cm thick (**Fig. 12**). This refractory lining must have been backed by substantial thicknesses of earth and/or stone, both for buttressing the structures to support the dome's thrust and for insulating the kiln-chambers.

CHAPTER 6 A TENTATIVE CHRONOLOGICAL CLASSIFICATION

A chronological classification of Liao ceramics is feasible with the aid of those datable and roughly datable Liao tombs in which their remains have been discovered. While the development of Liao ceramics has commonly been broken down into three phases, other ways of division are also possible. To date, a total of four views on this subject have been put forward (see Table 22).

Table 22 Different opinions on the chronological classification of Liao ceramics.

No.	Scholar	Chronological Classification		
1	Tong Zhuchen ⁵⁵¹ Liang Shuqin ⁵⁵² Mok ⁵⁵³	Early period (916-983)	Middle period (984- 1055)	Late period (1055-1125)
2	Zhang Guilian ⁵⁵⁴	Early period (916- 969)	Middle period (970-1055)	Late period (1055-1125)
3	Peng Shanguo ⁵⁵⁵	Early period (916-1004)	Middle period (1004-1055)	Late period (1055-1125)
4	Qiao Liang & Yang Jing ⁵⁵⁶	Early period Phase (916-947)	Middle period (1004-1055) Phase (947-1004)	Late period (1055-1125)

Combining my preceding analysis of Liao tombs and ceramics' typology, decorations, and technology with the knowledge of political, economical, and cultural changes occurring during the Liao kingdom, I am personally inclined to divide the development

551 Tong Zhuchen 1989, 78-89.

552 Liang Shuqin 1994, 30-41.

553 Mok 1985.

554 Zhang Guilian 1996.

555 Peng Shanguo 2003.

556 Qiao Liang & Yang Jing 1993, 382-90.

of Liao ceramics into three periods and five phases (see Table 23). According to this division, the Early period lasted from 907 to 969 AD, falling into two phases: Phase (907-926); Phase (926-969). The Middle period spanned the time from 970 AD to 1055 AD, consisting of three phases: Phase (970-982), Phase (982-1031), and Phase (1031-1055). Finally, the Late period stretched from 1055 to 1125 AD.

Table 23 A tentative chronological classification of Liao ceramics.

Shape			Early (907-969)		Middle (970-1055)			Late(1055-1125)
			Phase 907-926	Phase 926-969	Phase 970-982	Phase 982-1031	Phase 1031-1055	
Bag-shaped pilgrim flask	Group 1	Aa						
		Ab						
		B						
	Group 2	Aa				,	,	,
		Ab		,				
		B						
Lugged pilgrim flask								
Lugged vase	A							
	B							
Bowl-mouth bottle	A							
	B		,					
	C	√						
Carinate-shoulder bottle	A							
	B	√					√	
Long-neck vase	A					,	.	
	B							
Phoenix-head vase	A				,		,	
	B					√	√	
Spouted ewer	Aa						,	
	Ab							
	B							
	Ca						,	
	Cb		,					
	Cc						√	
	Cd						√	
Ce						√		

	Cf		√				√
	Da						√
	Db						√
	Dc						√
	Dd						√
	De		√				
	Df						√
	Dg						√
	Dh						√
	Di						√
	Dj						√
	Dk						√
	Dl						√
	Ea			√	√		
	Eb					√	√
	Ec						√
	Ed						√
	Ee						√
Chicken-leg vase	A						
	B			,	,		,
Chinese-style vase	A						,
	B						,
	C						√
	D					√	√
Jar	Aa						,
	Ab				,	,	,
	Ba						
	Bb						
	Bc						
	Bd						,
	Ca						
	Cb						√
	Da						√
	Db						√
Basin	A				,	,	,
	B					,	,
Spittoon	A					,	, , ,
	B						
	C						,
	D						√
Saucer	A						

	B				,		
	Ca						
	Cb						√
	D						√
	E						√
Ring-foot bowl	Aa					,	,
	Ab				,	''	,
	Ba		,	,	,	,	''
	Bb				,		
	Ca				,	''	''
	Cb				,		
	D						
	E		√				
Flat-base bowl	A				√		
	B						√
Dragon-handle bowl							√
Step-foot bowl							
Flat-base dish	A				√	√	√
	B				√	√	√
	C		√				
	D						√
Ring-foot dish	Aa					,	''
	Ab						,
	Ba						,
	Bb				,	,	
Oblong-lobed dish							√
Inkstone and brush-washer	A						√
	B						√
	C						√
Ocarina	A						√
	B						√
	C						√
Pillow	A			√	√		

	B					√	√
	C						√
	D						√
Box	A						
	Ba						√
	Bb						√
	Bc					√	
Lamp and incense burner	A						√
	Ba						√
	Bb						√
	C						√

It is important to mention that Liao ceramics stemming from different stages of development show different characteristics.

6.1 THE EARLY LIAO (907-947 AND 947-969)

The Early Liao stretched over the reigns of four emperors: Taizu (907-926), Taizong (927-947), Shizong (947-951), and Muzong (951-969). Of these, Taizu and Taizong were mainly responsible for the territorial expansion of Liao. Not only did they win the controlling power over Inner Mongolia, Liaoning, Jilin, and Heilongjiang, but also over the northern parts of Shanxi and Hebei. From Taizong's reign onward, large numbers of the Chinese fell under the rule of the Liao kingdom, causing a rapid and constant flow of Chinese cultural elements into Liao society. In brief, the Early Liao was a period of great success in terms of territorial expansion, and a time during which Liao society began to assimilate to Chinese culture.

However, the time was not yet ripe for the production of Liao ceramics in the early years of this period. Neither the political nor the economical situation was particularly stable, and Chinese potters who had been transferred to Liao territory needed time to acclimatize before they could apply their skills again. These circumstances explain the lack of excavated Liao wares dated to the early 10th century.

As evinced by archaeological excavations, Early Liao sites and the ceramics discovered thereabouts are quite limited in number, which is mainly due to the fact that traditional Chinese burial customs were not yet commonly followed by the Liao. In addition, the above-mentioned insecure political and economical situation did not provide favorable conditions for any large-scale ceramic production. Those rare Early Liao ceramics which could be recovered mainly stem from the tombs BS1(923), ZDJ (958), FMM(959), SSG1, SZG1, DQTL3, HLB1, HLDT1, ZKC1, ZKC4, QJZ, NZLYZ1, DHG1, HSN, MTYZ2, ZLK, BYD, EBD1, EBD2 etc.

Nevertheless, the Early Liao period is the formation stage of Liao ceramics. It can be further divided into two phases of development.

Phase (907-947), which marked the very beginning of the establishment of Liao, mainly saw the production of unglazed potteries of jars and long-neck bottles. Pertaining to decorations, comb patterns prevailed on such products. It was roughly around the time of Taizong's reign that Liao glazed ceramics began to be fabricated. However, they occur only in small amounts and simple shapes and are finished by rough techniques. As such, they appear to arise from the same system as their unglazed counterparts. The earliest roughly datable remains of glazed Liao ceramics are the ruins of the ancestral temple of Emperor Taizu, located in Zuzhoucheng, Inner Mongolia, and erected around the time of the Tianxian era (927-938) of Taizong.⁵⁵⁷ With regard to decorations it can be observed that the black-glazed ceramic tiles unearthed in the vicinity of the ruins are analogous to finds from the Bohai kingdom. The likeness suggests that a ceramic production already existed prior to 938 in the Liao kingdom, and that potters formerly belonging to the Bohai kingdom continued their work for their new ruler after their country was destroyed in 926.

Phase (947-969), marks the true beginning of the development of glazed Liao ceramics. During this period, the quantity of unglazed potteries rapidly shrank and the amount of glazed wares significantly increased. The most frequently occurring ceramic forms then contained bag-shaped pilgrim flasks, jars, lugged pilgrim flasks, long-neck vases, dish-mouth bottles, ewers, lugged vases, bowls, dishes, saucers, and spittoons, etc (**Chart 2, Timeline Table 1-Timeline Table 7, Timeline Table 10-Timeline Table 18**). Next to traditional Chinese forms, a number of typical Liao vessel types can also be observed among Early Liao wares, the most well-renowned of which is undoubtedly the bag-shaped pilgrim flask, an imitation of leather bags used by nomads. Two groups of bag-shaped pilgrim flasks can be classified, the larger one distinguished by a slab-handle, the smaller one by a loop-handle (**Chart 5**). The general features of all bag-shape flasks in this phase, are a plump, squat body and applied raised ridges. They indicate a molding in very careful imitation of the leather prototypes (**Timeline Table 1, Timeline Table 2**). The lugged pilgrim flask and lugged vase are two other vessel types popular during the Early Liao (**Timeline Table 3**). Both types display non-Chinese characteristics, such as lugs intended for the attachment of strings or thongs which simplified the transportation of the vessels. Coincidentally, this design was highly suitable for the Khitan's nomadic lifestyle.

557 Koyama Fujio 1962, 69-81.

From archaeological information which shows that many Early Liao ceramics are simple and unadorned, it can be deduced that an interest in decoration was still not well-established at the time. It was a plain style that Liao potters advocated.

In regard to glaze decoration it can be observed that mostly monochrome glazes were applied to ceramics during Phase II, for instance dark-green lead glaze, white glaze, brown glaze, and amber lead glaze (**Chart 7**). Only a rare number of vessels were additionally dotted with another color; yet, this appears to be an unintentional enhancement. The production of green-glazed ware in the Early Liao has usually been regarded as a revival of the lead glazing tradition of 8th-century northern-central China, but it should also have been marked down as the continuation of the ceramic production of the Bohai kingdom which was still producing mainly green-glazed ware during the very early 10th century. Liao green-glazed ware is generally soft, pinkish earthenware covered by a green lead glaze which is not tightly coherent to the body.

In context of the body decorations of Phase II ceramics, it may be stated that the main motifs are simple geometrical designs, such as raised ridges, incised or raised lines, concentric rings, impressed circles, etc. Incised or raised lines are mainly applied to jars, vases, or bottles. Furthermore, raised ridges and impressed circles most often occur on bag-shaped pilgrim flasks, and concentric rings on some lugged pilgrim flasks. A few rare cases of Early Liao vessels decorated with incised floral designs also exist.

The quality of the bodies of Early Liao glazed ceramics is highly variable. High-fired fine porcelains occur just as does high-fired coarse stoneware, or even low-fired earthenware.

The good quality and craftsmanship inherent in white porcelains of the Early Liao signifies, however, that Chinese potters, who had settled in the Liao area, helped to promote an impressive improvement of traditional Kithan potteries. Accordingly, those Early Liao white porcelain wares which appear to be imitations of Ding products manufactured by Chinese potters in Liao kilns reflect the technical disparity between Chinese and Kithan potters of the period. To date, the white bag-shaped pilgrim flasks unearthed from the FMM tomb serve as the earliest examples of a traditional Kithan vessel form produced by Chinese potters in a Liao kiln (**Cat. 2**).⁵⁵⁸ These flasks are glazed and fired into a hard and fine porcellaneous quality. The carrying tabs have a crest-shaped profile and the raised ridges imitate leather stitching, evincing that a more complicated treatment was possible. In particular, the additional ring-foot on some of

558 Zheng Shaozong 1956, 1-26.

the flasks embodies a marked Chinese element which is nowhere else to be found in Khitan pottery.

Some major Liao kilns were found to have been established in the Early Liao. The GWYC kiln at Chifeng, Inner Mongolia, is estimated to have started operation around the time of the reigns of Taizong and Shizong; the LQW kiln at Beijing, was established during the Huitong era (938-947) of Taizong; and the SJY kiln at Lindong, Inner Mongolia, may also be dated to the Early Liao.⁵⁵⁹ In regard of technique, these kilns were strongly influenced by Chinese kilns, particularly by the Ding kilns. This connection signifies that the Chinese potters who had settled in Liao territory, had begun to play an important role in the development of Liao ceramics as early as the mid-10th century.

6.2 THE MIDDLE LIAO (969-982 AND 982-1031 AND 1031-1055)

The Middle Liao, covering the reigns of the emperors Jingzong (969-982), Shengzong (982-1031), and Xingzong (1031-1055), was the age during which the Liao Empire experienced great economic success and flourished culturally. Emperor Shengzong, though still involved in conflicts with Song China, was also highly intent on consolidation, interior structuring, and the encouragement of agricultural production. His signature of the Chanyuan Treaty in 1044, determining a truce with the Song Empire, increased the political stability necessary for Liao's economic growth and cultural progress. Therefore, it was not until the Middle Liao that the influence of a Chinese cultural element on Liao society became more marked. Thenceforward, however, the Khitan mode of life to a certain extent converged towards a Chinese one. An increased demand for handicrafts resulted in the rapid development of Liao ceramics, making the Middle Liao a boom period of clay production.

Contrary to the scarcity of Early Liao discoveries, an abundance of Middle Liao remains have been recovered, also containing considerable amounts of ceramics. Thus, archaeological information for the study of Middle Liao ceramics can be supplied more adequately. Based on their typological analysis, as well as on their known connections to different states of ceramic production, the development of Middle Liao ware can be further divided into three phases.

Phase (969-982) saw an advance of the production of Liao ceramics and represents the beginning of a period of prosperity. One of the important Liao tombs dated to this time is the YMT7 (977) tomb. Other significant but undateable tombs like GDG, BZLG, DEQG, DJWP, AXZ, and XTTG3 have also been assigned to that phase. It is obvious from

⁵⁵⁹ Jia Zhoujie 1973, 241-43; Li Wenxin 1958, 97-107; Lu Qi 1978, 26-32.

the ceramics' forms produced at the time, that the bag-shaped pilgrim flask had undergone a considerable change since the Early Liao: Type B of Group 1 and Type Aa of Group 2 were the most characteristic and prevalent forms among Phase I flasks. It can also be observed that while the amount of chicken-leg vases increased during this phase, lugged vases almost disappeared and bowl-mouth bottles vanished completely. Instead, phoenix-head vases and a new form of the Type B ewer came into fashion (**Timeline Table 1-Timeline Table 20**).

Phase II (982-1031) constitutes the most prosperous stage of Liao's ceramic production. Counting among the important Liao tombs dated to this time frame are the tombs YLYN (986), HYM (1011), LYJ (1000), SJG1 (1002), WZM (1005), HXM (1017), CGZZ (1018), GYY (1020), GZX (1026), XJM (1029), etc. An approximate estimation of dating also sees such significant, if undateable, tombs as BL4, CGB11, DSLT1, QHM4, SQ1, KL3, QCH, BL1, WLC, ZKC2, ZKC3, and PJG1 to belong into Phase II. Both the variety of forms and the production volume of bag-shaped pilgrim flasks were increased. It appears that while the types Aa, Ab and B of Group 1 as well as Aa and Ab of Group 2 are the most popular forms, Type B of Group 1 represents the form most characteristic of the period. Various jars and spouted ewers were equally favored in this phase, and new forms of Type Ab, Type B, and Type E spouted ewers came into use. Lugged pilgrim flasks, however, gradually vanished from production (**Timeline Table 1-Timeline Table 20**).

Phase III (1031-1055) marks a decline from the prosperity of Liao's ceramic production of the preceding phase. The number of Phase III Liao ceramics unearthed from pagodas exceeds the amount of those found in Liao tombs. Accordingly, examples were recovered from pagodas like BTTG, BTDG, WGJGSLT, QZBT, BZCT, and, less frequently, from a number of datable tombs, such as JGFR, QHM1, LRY, etc. Several important, undatable tombs, for instance DXG1 and DYZ3 etc., are also estimated to belong to this phase. On the whole, a gradual downturn of Liao's ceramic production, concerning varieties, forms, and quantities, can be observed. The variant forms of the bag-shaped pilgrim flask with slab-handles (Group 1) disappeared at the time. Still, a variation of the Type B spouted ewer emerged, in case of which the dish-mouth had been changed into a lobed cup form and the body was occasionally adorned with a floral decoration (**Timeline Table 1-Timeline Table 20**).

In brief, it is the variety of shapes which poses the most notable feature of Middle Liao ceramics. Among all the different vessels fabricated at the time, the bag-shaped pilgrim flask occupies the dominant position (**Chart 3**). More specifically, bag-shaped pilgrim flasks belonging to Group 2 account for the highest number of variant forms. For

instance, it can be observed that in this particular period they tended to appear with double-handles with double-holes instead of with a single handle with a single hole, and were also frequently equipped with a matched cover on the tubular spout. The amount of Group 2 bag-shaped pilgrim flasks with a loop-handle, which were most often formed into a flat elongate body, markedly increased (**Chart 5**).

Raised ridges in imitation of leather stitching disappeared from bag-shaped pilgrim flasks of the types Aa , Aa , and Ab of Group 2, suggesting a deterioration of the resemblance of the leather prototype in this particular kind of vessel by the early 11th century (**Timeline Table 1, Timeline Table 2**). Vases and bottles of the time display more elongate bodies (**Timeline Table 3 -Timeline Table 6**). The mouth of the Type A long-neck vase is deeper than before (**Timeline Table 5**). Despite the fact that the production of some vessel types popular in the Early Liao, e.g. lugged vases and lugged pilgrim flasks, persisted for some time, it appears to have eventually ceased in the 11th century (**Timeline Table 3**). The most distinctive of the new forms which appeared in the Middle Liao period is the phoenix-head vase. Archaeological evidence shows that this type of vessel emerged during Phase of the Middle Liao period, as it features two unique characteristics of the time, a lobed dish-mouth and a phoenix-head with a pearl in its beak. From Phase of the Middle Liao onward, the lobed cup-mouth became popular with phoenix-head vases. In this particular case the neck is ribbed, the head is less elaborately sculptured, and the beak is modeled to represent nothing more than a simple hook (**Timeline Table 6**). In comparison to Early Liao wares, the bases of bowls and dishes are now decidedly smaller and the bodies deeper. Overall, the forms of lobed bowls and dishes follow the ceramic tradition of the Late Tang and the Five Dynasties period of North China, supposedly originating in metal wares. In addition to the old model of a five-lobed mouth for bowls and dishes, the Middle Liao period saw dishes with six- to twenty-one-lobed mouth rims and lobed bodies (**Timeline Table 16, Timeline Table 18**). Furthermore, the square dish emerged in Phase of the Middle Liao, the scalloped edges and sometimes beaded ornaments of which indicate its relation to metalwork. Both the intact pieces unearthed from the Liao pagodas BZC (**Cat. 1132**) and CYBTTG (**Cat. 1133-Cat. 1135**), as well as the fragments found in the QHM2 (**Cat. 1136**) tomb, show that this vessel form did not appear until the end of the Middle Liao. The findings also exemplify that it appeared first as high-fired stoneware before being produced as low-fired lead-glazed ware (**Timeline Table 17**).⁵⁶⁰

560 Qi Xin & Liu Jingyi 1980, 147-58; Li Wenxin 1954, 163-202.

In comparison with Early Liao products, a greatly increased interest in decoration may be observed in wares of the Middle Liao period. Adornments are not only more frequent but also display an advanced technique.

In context of glazed decoration, it was monochrome-glazed ware which occurred most frequently during the Middle Liao. However, white glaze, green glaze, amber glaze and teedust-green glaze, as well as low-fired lead yellow glaze also came into use (**Chart 8**). A significant increase of intentional, painted designs on the monochrome ground can also be observed, most of which were applied on designs previously incised on the ceramic body. Examples of such embellishments are white-glazed grounds incised with floral designs which were then painted in green (**Pl. 282-Pl. 285**) as well as white-glazed grounds with incised floral designs painted in green and brown (**Cat. 732, Cat. 735**). Further to be mentioned in this context is the green or brown pigment applied to the raised ridges' designs of white-glazed bag-shaped pilgrim flasks, which was intended to emphasize the imitation of leather stitching (**Cat. 115-Cat. 121, , Cat. 125-Cat. 130**). The use of green or brown glaze in decorations on white grounds can also be found on some bag-shaped pilgrim flasks of the types Aa and Aa of Group 2, which were produced during Phase of the Middle Liao (**Cat. 115-Cat. 121, Cat. 125-Cat. 130**).

As regards body decorations during the Middle period, a number of innovative techniques, i.e. carving, cutting, impressing, and applied relief were added to the traditional Early Liao methods of embellishment, i.e. raised ridges, incised or raised lines, and concentric rings. Other old designs were replaced, for instance, the old small circle pattern impressed by a tubular instrument, or the small concave circle design impressed by a solid cylindrical tool. Furthermore, a surge of incised floral designs is a marked feature of the period. Type B bag-shaped pilgrim flasks of Group 1, like those unearthed from the GYY tomb, are not only decorated with simple incised scrolling vines but also with other motifs applied in relief (**Cat. 69, Cat. 70**).⁵⁶¹ Incised peony designs were also highly popular. While the dishes engraved with peony roundels which were unearthed from the GYY and XJM tombs are examples of traditional Chinese-style white wares (**Fig. 28, Fig. 29**)⁵⁶², analogous designs also exist on vessel types which are more distinctly Liao, such as pilgrim flasks and long-neck vases (**Pl. 259, Pl. 257, Pl. 258, Pl. 254, Pl. 255**,). Both of the GYY and XJM examples can be roughly dated to the late Middle Liao period and onward. Cutting slip floral designs of this period were executed

561 Zhu Zifang & Xu Ji 1983, 168-95.

562 Zhu Zifang & Xu Ji 1983,168-95.

in a Cizhou variation of the sgraffito technique. The YMT7 long-neck vase of Type A probably constitutes the best example of this method. (**Fig. 36**). The slip was cut away from the margin area of the peony floral motif in order to expose the grayish color of the body. The resulting contrast between the body surface and the white ground succeeded to emphasize the floral pattern. The phoenix-head vases in **Pl. 278** and **Pl. 279** were decorated with the same technique. However, the execution in these cases is extremely rigid and operates with an additional green glaze. Adornments of impressed floral designs mainly occur on square dishes of finely made, white-glazed porcelain, samples of which were discovered in the QHM2 tomb and in the pagoda BZC CYBTTG (**Cat. 1132-Cat. 1136**).⁵⁶³ These vessels exemplify that the Liao decorative technique of molding was only applied to white ware in the Middle period and not yet to lead-glazed ware. Moreover, they signify that a new and more meticulous style of decoration was coming into being. Carved ornaments are present in carved, overlapping lotus petal designs on white-glazed porcelains (**Fig. 41-Fig. 46**). They were commonly copied from Ding-type designs of northern China, but display a slightly stiffer style than the original. Typical relief patterns on Middle Liao ceramics appear on the phoenix-head of the phoenix-head vase. Equally prevalent during the Middle Liao period were human figures, dragons, rolling phoenixes, firing balls, and raised ridges etc. applied to Liao ceramics in relief. Furthermore, relief designs in the form of small petals can be found in the group of green-glazed ware from the QCH tomb (**Cat. 351**) and on the phoenix-head vase from Tomb SQ1 (**Cat. 352**).⁵⁶⁴ In the main, the decorative motifs discovered on ceramics of the Middle Liao period contain peonies, scrolling vines, lotus petals, butterflies, rolling clouds, firing flames, dragons, phoenixes, human figures, and so on. Among these the three motifs first listed were the most popular ones.

As for body varieties, the Middle Period saw pinkish earthenware, grayish or yellowish stoneware, and white porcelain ware. Green-glazed earthenware vessels unearthed from the QCH (**Cat. 351**) tomb best illustrate the continued popularity of this kind of produce.⁵⁶⁵ The influence of Ding ware on white porcelain vessels of the Middle Liao is quite striking. For instance, it is easy to trace carved lotus petals, which were a favored decoration among Ding potters, on vessel recovered from Middle Liao tombs.⁵⁶⁶

563 Qi Xin & Liu Jingyi 1980, 147-58; Li Wenxin 1954, 163-202.

564 Xu Yulin 1977, 44-51; Jin Fengyi 1980, 17-29.s

565 Jin Fengyi 1980, 17-29.

566 Su Tianjun 1964, 49-53; Feng Yongqian 1960, 15-24; Xu Yulin 1977, 44-51; Pan Xingrong 1965, 374-76.

Furthermore, the Type Ab spouted ewer discovered in the GYY tomb exemplifies the modification of a Ding ware model into pottery of slightly inferior quality to match Liao taste (**Cat. 430**).⁵⁶⁷ Similarly rough Liao white ware also occurs among many other excavated examples, such as those from the tombs GYY, GZX, and HYM.⁵⁶⁸ However, the ceramics unearthed from the pagoda at Yixian and the tomb of WZM at Beijing, represent Liao products of finer quality.⁵⁶⁹ They were formerly attributed to Ding kilns, but are now regarded as products of the Liao kilns of LQW.⁵⁷⁰

6.3 THE LATE LIAO (1055-1125)

The period of the Late Liao stretched over the reigns of last two emperors: Daozong (1055-1101) and Tianzuodi (1101-1125). It was an age during which the Liao Empire suffered a significant loss of national strength. In the face of internal disorder and natural disasters, the prosperity of the Middle Liao could not be preserved after the mid-11th century. The simultaneous rise of the neighboring tribe of the Jurchen in the north-east further accelerated the downfall of the Liao kingdom. Its collapse may be said to have come by as quickly as had its growth in Taizu's and Taizong's times.

However, the rapid decline of political power in the Late Liao did not coincide with a downfall of the ceramic development of this phase. The continuing assimilation of Chinese culture made Liao people, and particularly their rulers, eager competitors for a luxurious lifestyle. Very extravagant burial ceremonies and increasingly complicated and elaborately decorated tomb structures, as well as the emergence of mortuary objects, indicate not only that the demand for ceramics remained on the increase, but rather that there had never been a greater stimulation of ceramic production before.⁵⁷¹ Thus, the Late Liao's ceramic production continued independent of the kingdom's decline, and even reached new stages of development. It is a sudden change period of the developing process of Liao ceramics.

The popular adoption of traditional Chinese burial customs accounts for the fact that the number of Late Liao tombs surmounts that of the Middle Liao. Archaeological excavations show that among those numerous burial sites are some particularly

567 Zhu Zifang & Xu Ji 1983, 168-95.

568 Huang Xiuchun et al. 1984, 361-81.

569 Su Tianjun 1964, 49-53; Beijingshi wenwu guanlichu 1962, 35-40.

570 Lu Qi 1978, 26-32.

571 For the structure of Liao tombs, see Wang Qiuhua 1982, 43-46.

important ones with regard to the ceramics contained therein. These are the datable tombs of QHM2 (1057), ZKY (1060), SFC (1066), XTM (1070), XFJ (1072), XDW (1075), KL1(1080), XBTB (1081), XXZ (1089), XPL (1090), ZKM (1090), WHW6, WHW3, ZKZ, ZWZ, DLZ, SWM (1099), YLQ (1108), GSM (1107), HSX (1111), ZTM (1111), MZW (1113), DWD (1113), ZSQ (1116), ZGY (1117), ZSB (1115-1144), etc. and the undatable tombs of BTYZ, LTL, MJ1,XDM, HPY1, FZZ, BL3, XLZZ1, XLZZ2, XLZZ3, XLZZ4, JFYZ, CDMM, WLHD, HQY6,PJG2, PJG3, XPJG, GS1, JSF, etc.

Three main observations can be made in regard of ceramic shapes of the Late Liao period: firstly, the proportion of Khitan-style vessels decreased sharply; secondly, the amount of traditional Chinese-style ceramics increased rapidly (**Chart 4**); and thirdly, the majority of all shapes tended to be simplified. The array of forms mainly contains the bag-shaped pilgrim flask, the phoenix-head vase, the chicken-leg vase, the long-neck vase, the spouted ewer, the bowl, the dish, the jar, the saucer, the spittoon, the oblong-lobed dish, the floriated round dish, etc. Group 1 of the bag-shaped pilgrim flask with its slab-handle vanished, and the remaining Group 2 (with a loop-handle) was modified to display an elongate, round body with a ring-foot (**Chart 5**). It is difficult to trace the imitation of the leather bag prototype's stitching in flasks of this period. Examples of Late Liao bag-shaped pilgrim flasks are those discovered in the JFYZ and QHM2 tombs (**Cat. 168, Cat. 177**).⁵⁷² They belong to Type Ab of Group 2, but have a body which is more vase-like and lacks any raised ridges. The pouch-form of the body, derived from a leather prototype, however, is retained in these exemplars, a fact which suggests that pilgrim flasks of the Late Liao deteriorated in terms of their resemblance to a leather bag. It should also be noted that bag-shaped pilgrim flasks were no longer as commonly produced as during the Early and Middle Liao. Seeing as several important Late Liao tombs, for instance XLZZ, KL1, and ZSQ, did not contain any pilgrim flasks⁵⁷³, it appears that this very distinctive Liao vessel type had lost its standing and was no longer required by Liao people. However, bag-shaped pilgrim flasks belonging to Type B of Group 2 developed into a different direction, and although they were only produced in small amounts anymore, their remains can still be discovered in tombs of the very late Late Liao dynasty – a time at which the production of Type Ab of Group 2 must already have ceased (**Timeline Table 1, Timeline Table 2**). The long-neck vase, which had occupied a prevalent position in the Early and Middle Liao periods, changed the form of its mouth from a dish shape to large, flaring trumpet shape, and was mostly glazed in

572 Xiang Chunsong 1979, 330-34.

573 Li Yiyu 1961, 44-49; Hebeisheng wenwu guanlichu et al.1975, 31-39; Chen Xiangwei & Wang Jianqun 1973, 2-18.

monochrome yellow or green (**Timeline Table 5**). The phoenix-head vase, another common Liao vessel type, continued to be produced until the late 11th century at least. Unlike the Middle Liao version, which is molded in a detailed characterization of the bird, the Late Liao phoenix-head vase has small, finger-pinched clay pads or strips applied in relief to indicate a beak, eyes, and ears. The latest examples of Late Liao phoenix-head vases discovered in datable tombs are from the XXZ tomb, dated to 1089.⁵⁷⁴ The high popularity of three-colored ware brought about the emergence of some new forms during the Late Liao, for instance oblong-lobed dishes, round-lobed dishes, inkstones, miniature mortuary objects, etc. The square dish, which had already been produced in white stoneware during the Middle Liao, also became popular in polychrome glazes (**Timeline Table 19, Timeline Table 17, Timeline Table 6, Timeline Table 8, Timeline Table 17-Timeline Table 20**). Melon- or gourd-shaped spouted ewers were equally in vogue at the time. Exemplars of this type are the melon-shaped ewer unearthed from a tomb at HQY6 (**Cat. 489**) and the gourd-formed ewers found in the KL1 tomb (**Cat. 455**).⁵⁷⁵ Even though some gourd-shaped ewers are covered with a lead glaze, this particular KL1 example is of a white porcellaneous quality, revealing the high technical standard of Ding ware imitation in the Late Liao.

Archaeological analyses show that an interest in decoration, which had already increased during the Middle Liao, became even more pronounced in the Late Liao. The most prominent decorative feature of the period is the polychrome lead glaze which dispossessed monochrome glaze of its dominant position.

View from the glaze decoration, polychrome kept pace with the monochrome. The color range of monochrome glazes contained white, yellow, green, black, brown, and teedust-green etc. In the group of polychrome glazes, the prominent position was occupied by three-color glazes (**Chart 9**). Ceramics decorated with monochrome glaze are most often bag-shaped pilgrim flasks, long-neck vases, phoenix-head vases, chicken-leg vases, spouted ewers, etc. While yellow-glazed ware was not as commonly produced as green-glazed ware before the Late Liao, its popularity increased after the mid-11th century. This development is verified by the discovery of ceramics in the Late Liao tombs of XLZZ1-4, ZSQ, ZWZ, BTYZ etc, among which yellow-glazed vessels constitute the largest proportion.⁵⁷⁶ A shared feature of many yellow-glazed and green-glazed wares is that they are only partially varnished so as to reveal the slipped

574 Yan Yu 1960, 34-35.

575 Chen Xiangwei & Wang Jianqun 1973, 2-18.

576 Li Yiyou 1961, 44-49; Hebeisheng wenwu guanlichu et al. 1975, 31-39.

body of the lower part of the vessel. As this characteristic cannot be found in previous phases, all partially covered Liao vessels may safely be referred to belong to the Late Liao, for instance the yellow-glazed gourd-formed ewer exhibited in the Liaoning Provincial Museum (**Cat. 460**). The origin of this partial glazing technique can be found in the tradition of Tang ceramic decoration. The most striking development of Late Liao ceramics is the emergence of a large quantity of three-colored lead glazed earthenware. In these cases, the polychrome colors comprised yellow, green, and white, and the ceramic shapes mainly contained oblong-lobed dishes, round dishes, square dishes, floriated dishes, ocarinas, inkstones, boxes, spouted ewers, etc. On the one hand, the earliest example of this Late Liao three-colored ware is an ink-stone discovered in the SFC tomb (1066) (**Cat. 1204**).⁵⁷⁷ The earliest exemplars unearthed from actual Liao tombs, on the other hand, are the four shards discovered in the ZDJ tomb at Beijing, dated to 958, and a pillow found in the ELC tomb, at Tongliao, Inner Mongolia, which is roughly dated to a point in time between the late 10th to the early 11th century.⁵⁷⁸ The latter piece in particular, is very likely to have been made by Liao potters, as its surface is painted with a peony design typical of Liao. It also shows that Liao potters who inherited techniques from kilns in China proper and from the Bohai kingdom, already practiced polychrome glazing in the early part of the Liao dynasty. In the light of this observation, it seems unusual that Liao three-colored earthenware was not commonly produced until after the mid 11th century. A possible explanation for this lapse is that that the production of Liao three-colored ware was, to a considerable extent, only stimulated by the extravagant demand for burial objects (*mingqi* in Chinese) of Late Liao funeral ceremonies a type of product produced not for daily use but only for funerary service. As can be deduced from Tang ceramics, three-colored ware hardly occurs among utensils of daily use. The same can be said for Liao polychrome lead-glazed ware. Moreover, as shown by finds from the FMM, QCH, and ZJYZ tombs, the practice of burying large quantities of gold and silverware with the dead was already quite common in the early part of the Liao dynasty.⁵⁷⁹ This extravagancy may have been the cause of the introduction of sumptuary controls in the year 1044, when the Liao court laid down a rule restricting the use of silver ware to the burials of high ranking officers only.⁵⁸⁰ Even though this regulation may have been occasionally violated, the quantity of

577 Li Wenxin 1985, 10-22.

578 *Beijingshi wenwu gongzuodui* 1962, 246-52; Zhang Baizhong 1985, 56-62.

579 Zheng Shaozong 1956, 1-26; Jin Fengyi 1980, 17-29; Feng Yongqian 1960, 15-24.

580 Tuo Tuo et al. 1974 ed., 229.

metalwork which has been discovered in Late Liao tombs is tellingly small. It is likely that Liao three-colored earthenware was produced in reaction to the ban on gold and silver ware in funeral services. This hypothesis is supported by the fact that many of these wares are modeled upon metalwork, both in terms of vessel form and decoration. Apparently, the growing popularity of Liao three-colored ware in the wake of the 1044 restrictive ruling on silver and gold burial object was no accident.

Concerning Late Liao body decorations, it can be observed that those incised patterns which were still prevalent on the monochrome glazed ceramics of the Middle Liao period decreased, whereas the appearance of molded designs strongly increased on three-color lead-glazed earthenware. These adornments are colorful, intricate, and luxurious, if representing a rather rough craftsmanship. Nevertheless, it is obvious that Late Liao potters were quite eager to achieve a more elaborate ornamental effect, and the technique of molding is undoubtedly one of the most important factors in the advancement of the development of Liao decorations (**Fig. 145-Fig. 162, Cat. 503-Cat. 506, Cat. 509-Cat. 511**). It was also during the Late Liao that a group of slipped vessels painted in brown and black appeared (**Cat. 611-Cat. 618, Cat. 673-Cat. 679**). They display the influence which Cizhou-type wares exerted on Liao ceramics. In conclusion it must be observed that, unfortunately, the fall of the Liao kingdom in 1125 stalled a further advancement of the Liao painting technique.

The distinct density and complexity of Late Liao vessel decorations produce effects quite different to the ones achieved by the main Early and Middle Liao techniques of incision and carving. Still, the tradition of adding incised peony designs remained in fashion, as verified by a new type of the long-neck vase (**Pl. 253**). Liao ceramics decorated in Cizhou-style also continued to be produced in the Late Liao, only sometimes with new variations introduced by Liao potters. Heavy jars with thick mouth rims, such as the jar types Aa and Bd, serve as good examples for such modifications. They are decorated in sgraffito, by incision, or by incision combined with the addition of black glaze - the last type being a Liao invention (**Cat. 611-Cat. 618, Cat. 673-Cat. 679**). The incised lines and outlines for their particular type of peony scroll show strong and forceful movements which differentiate these designs from many other Liao decorations. The extreme intricacy and the high sculptural effect of some melon-form ewers are undoubtedly new achievements of Late Liao potters as well (**Cat. 493-Cat. 498**).

It was ornamental motifs which were most frequently used to embellish Late Liao ceramics. Among these, many new subjects emerged, such as wave patterns, swimming fish, plantain leaves, etc. Also, the increase of several traditional motifs can be noted, for

instance of lotus rosettes, cloud scrolls, peony scrolls, etc. They often coexist on the same decorative surface.

CHAPTER 7 CONCLUSION

China is a multinational country, and the ceramic culture created by its heterogeneous ethnic nationalities is characterized by a diversity of materials, skills, forms, and decorations. Constituting a distinct form of artistry, Liao ceramics in their entirety represent a unique style in the history of Chinese ceramics, the characteristics and varieties of which are prominent among the produce of national minorities. It has been an integral part of this study to stress that Liao potteries, despite a strong influence of Chinese techniques, for the most part retain a Khitan nomadic taste, and that it is this unique feature which accounts for their distinctiveness and historical relevance.

The research scope of this archaeological study mainly included glazed ceramics which were produced within the territory of the Liao Empire (907-1125). Furthermore, it was based on Liao ceramic materials unearthed from Liao tombs, a total of 243 of which have been taken into account, including 59 datable tombs and pagodas and 184 undatable tombs. It was possible to arrive at estimate age determinations of otherwise undatable tombs by comparing both information about their forms and stylistic data of the ceramic objects they contained with dated discoveries of both burial chambers and potteries. Subsequently, typological analyses of different ceramic shapes were achieved. Finally, combining these results with aspects of pottery technique and decoration, three stages of development of Liao ceramics could be classified and a number of sequence timetables were generated to convey their evolution to the reader at a glance. Given that no comprehensive scientific database on Liao ceramics has been established to date, this study's chronological framework represent a highly convincing reference standard for the identification and dating of museum and private collections, which may well serve as the foundation for future studies.

Equally important to this work as those Liao ceramics excavated from the Empire's tombs were large quantities of Liao shards recovered from its various kiln sites. As a matter of fact, LQW and GWYC remain the only tracts which have ever been scientifically excavated, and a final report only followed from the former investigation. In order to compensate for this lack of expertly examined materials of the majority of Liao kilns and to enhance the scope of this study, I personally investigated numerous locations, such as the GWYC, SJY, and BYGL kilns in Inner Mongolia, the GGT kiln in Liaoning province, the LQW kiln in Beijing, as well as the JZY, DTY, and HRY kilns in Shanxi province. Resulting from my research is a multitude of firsthand photos and illustrations of Liao ceramics and production sites which encourage further surveys.

The above-mentioned method of comparison for the purpose of identification and dating is also applied to museum collections of yet unclassified Liao ceramics which exist in large quantities, multiple shapes, and diverse varieties. However, former studies have only ever concerned the congeries of one single museum at a time. While Chinese scholars have exclusively focused on collections visible in China mainland, foreign scholars have mainly concentrated on corpuses housed in other countries. In order to achieve as comprehensive a scope of materials as possible, museum collections worldwide, as well as excavated objects and private collections were incorporated in this study. Not only do these goods provide a solid foundation for an in-depth analysis, but they also constitute the most copious body of study material ever contained in one and the same research paper.

A conjoint worldwide study of Liao ceramics has been deterred by the language barrier which makes it very difficult for foreign scholars to obtain translations of newly published Chinese research materials. It was therefore a deliberate decision to issue this comprehensive archaeological and typological study of Liao ceramics in English, particularly with regard to the fresh data included. My hope is to thus build a bridge which will make new information accessible to western scholars and to advance Liao ceramics to the status of an international research subject.

Chapter 1, the introduction, presented the research scope, methods, and sources of materials, the analytical difficulties, and objectives of my study. Furthermore, it provided a geographical and historical framework of the Liao dynasty and summarized all relevant publications in the field of Liao ceramic studies to date. I organized this compilation of scientific writing according to the three stages around which my following analysis is also structured. Namely, these phases are the initial stage of the study of Liao ceramics, the subsequent rapid development period, and the final surge and in-depth development period. At each stage, the developments and focal points of archaeological scholarly literature were separately concerned. Furthermore, the summary of ceramic studies research papers was divided corresponding to kiln sites and tombs as well as to the languages of the publications. Only in this manner the particular kind of attention paid to Liao ceramics in different periods and in different countries could be adequately represented. For example, it transpired from the collected data that the center of the study of Liao ceramics shifted from Japan to China during the seventy-year-period of the first stage, and that western scholars, too, performed some perfunctory research projects during that time. Moreover, it could be observed that the initial stage was rich in publications of both books and articles. Generally speaking, the research field of Liao materials proved to be a new and long-neglected branch of Chinese ceramic studies, in which great progress has been made in a relatively short time. A

quite significant number of monographs were published in the past half century, forming a firm foundation for the research field, allowing for the further advancement of the study of Khitan culture and Liao history, and giving fresh impetus to related Central China ceramic sciences.

Chapter 2 elaborated on archaeological discoveries of Liao ceramics which were mainly unearthed from Liao kiln sites, tombs, and pagodas. Prior to the discussion of the actual finds, the places of discovery were illuminated. It was illustrated how one of the principal achievements of Liao potters was their encouragement of the growth of the ceramic industry in the north-eastern region of China. My analysis also revealed that it was only from the Liao dynasty onward that large numbers of potteries in this region were produced with a relatively accomplished technique. Several Liao kilns, such as the GWYC kiln at Chifeng, Inner Mongolia, the JZY kiln at Datong, Shanxi province, the GGT kiln at Liaoyang, Liaoning province, and the LQW kiln at Beijing, were shown to have operated until after the end of the Liao dynasty, some them even improving in these subsequent years. A total of 16 kilns were included, most of which located around the five capitals of the Liao Empire. Their surroundings were depicted as abundant in sources of clay, fuel, and water, all necessary for ceramic production. The most representative kilns were the SJY kiln near the Liao Supreme Capital, GWYC close to the Liao Central Capital, the GGT kiln in the proximity of the Liao Eastern Capital, the LQW kiln close-by the Liao Southern Capital, and the JZT kiln in the vicinity of the Liao Western Capital. The origin for their importance was connected to their status as economical centers of the Liao dynasty as which they generated a high demand for ceramics. It could be concluded from this observation that Liao kiln sites were erected especially to meet the people's daily need of ceramic wares. The second section of Chapter 2 focused on finds of Liao ceramics from the previously introduced tombs, pagodas, and other sites of discovery. The data was conveniently represented in a number of charts which listed a total of 59 datable Liao tombs and pagodas, and 184 undatable Liao tombs. Further contained was a table which compared the datings of Liao tombs. As such, this second section laid groundwork for the following chapters, especially for the typological and chronological analysis of Liao ceramics. In order to achieve an identification of Liao ceramics from Liao tombs, I relied on excavation reports and the studies of experts, but also on the results of my own investigations of Liao kiln sites and numerous scans of unearthed samples.

Chapter 3 constituted the core of this study. It contained the systematic typological analysis of 27 forms of Liao ceramics and was structured around the developing sequence of each of these shapes. It appeared that Liao ceramics are marked by elegance in primitiveness, delicacy in simplicity, and exquisiteness in coarseness. They were

revealed to be products of the merged cultures from beyond the Great Wall and the inland, representing the life and social habits of northern Chinese nomadic people and their conceptions and comprehensions of vessel forms and styles. Overall, two styles could be distinguished, the Kithan and the traditional Chinese Han style. The former is richly featured in the Kithan nomadic culture and comprises such forms as the bag-shaped pilgrim flask, the lugged pilgrim flask, the chicken-leg vase, the lugged vase, the phoenix-head vase, the oblong-lobbed dish, the square dish, the inkstone, the brush-washer, and some animal- or plant-shaped ewers. It was observed that the form of the bag-shaped pilgrim flask underwent a change, gradually developing from a round bottom to a flat, upper part with its spout and handle producing a rich and harmonious visual effect. The delicate conversion of the entire vessel and into a better shape is a perfect example of the advancement of traditional forms which reflect experiences and intelligence in life and practice. In view of the fact that objects suspended from the back of a horse or a camel should be oval-shaped, the difficulty of producing an oval ware in one piece was addressed. While less capacity in such ware is thus to be anticipated, the Liao bag-shaped pilgrim flask, which has a round upper part and an oval lower part, was presented as a unique sample with a good capacity. In the same context it was related that this particular form results from the adoption of a leather vessel and its special features into ceramics. The unique form and style of the Liao bag-shaped pilgrim flask is the representative of Liao ceramics. Furthermore, traditional Chinese Han-style ceramics, such as the bowl, the dish, the saucer, the basin, the jar, the pillow, and some spouted ewers and vases, were shown to also occupy an important position among Liao ceramics, due to the fact that next to the Khitan ethnic group, the Han people were an integral part of Liao's population and dominated in numbers in the south. Finally, was demonstrated that not only did the Han continue to use Chinese-style ceramics, but the Khitan, too, adopted and developed potteries from China proper.

Chapter 4 concerned the decorations and inscriptions of Liao ceramics. It showed that Liao ceramic ornaments and colors followed the example of China proper in traditionally formed wares forms of the Central Plains, and the example of the nomadic decorative style in Kithan wares. Moreover, it emphasized the potters' creativity in context to the technique of combining nomadic forms with traditional Chinese decorations. Another insight gained was that the special characteristics of Liao ceramics are the direct result of different life-styles in different regions, different aesthetic preferences, and the inescapable influences of ceramics of China proper. The characteristic vitality represented in the patterned decorations of Liao ceramics were proved to show that potters could freely apply their skills without any sense of restraint. Chapter 4 was structured around the representation of glazed decorations, patterned

decorations, and inscriptions. The section on glazed decorations further elaborated the aspects of monochrome- and polychrome-glazed ornaments, for instance of three-color-glazed earthenware, the one variety of Liao ceramics which combines all the most prominent Liao decorative features. The part on patterned decorations discussed aspects of different decoration motifs, the layouts of designs, and decorating techniques. Sixteen motifs were addressed therein, among them the most popular subjects to be found on Liao ceramics, the lotus and the peony. More particularly, the former ornament was shown to include forms of expression like overlapping lotus petals and rosettes, the latter of peony sprays and scrolls. A typological method was applied to analyze the diverse layouts of designs, focusing on the decorations of three-color-glazed ceramics, such as the oblong-lobed dish, the eight-lobed round dish, and the square dish. Overall, six different layout techniques were introduced, for instance incised, carved, molded, relief carved, applied relief, and painted decorations, most of which following traditional Chinese methods equipped with unique Kithan features. The guan (official) and xinguan (new official) inscriptions on Liao ceramics were shown to have attracted more attention and discussion than any other kind of engraving, and three contrary positions on the significance of the guan mark were quoted. I argued in favor of the view that guan- and xinguan-marked ceramics were supplies for government service, used by bureaucrats or presented to representatives of other countries. Furthermore, it was established that these wares were not necessarily produced by an official kiln. The achievement of a better understanding of guan- and xinguan-marked ceramics was acknowledged, but it was also noted that some questions remain unanswered in this context; for instance, if there is a connection between Liao and Ding kilns which both produced guan- and xinguan-marked wares.

In Liao ceramic studies, as in any other ancient ceramic research field, manufacturing techniques constitute a substantial aspect. Chapter 5 dealt not only with the processes, instruments, and kilns of Liao's ceramic production methods, but also included chemical and petrography analysis data. While I have not obtained these results myself, it is for the first time that all the information of former scientific analyses has been integrated in one work to supplement one another, an achievement which I consider important at the present stage and for the future of Liao ceramic studies. It was demonstrated that this technical information can help to distinguish Liao potteries from other kinds, for instance Liao white wares from those of Ding, Xing, or Cizhou, and Liao three-color lead-glazed wares from their Tang counterparts. Concerning the chemical composition of glazes, two dark-green-glazed earthenware shards of the LQW kiln north of Beijing were quoted as highly significant finds: analyzed in 1989, they contain boric oxide as a major glaze flux and only negligible lead oxide contents, making them the earliest

discoveries of boric oxide glazes worldwide to this day. As for loading instruments and methods, different ceramic varieties were shown to use different procedures and supporters. It was illustrated that Liao high-temperature stonewares for instance were open-fired in cool-burning kilns of the mantou style, while stacked bowls were separated by four clay spurs and the bases of the wares remained unglazed. Lead-glazed bowls and dishes on the other hand were separated by triangular setters during firing, and often retained three small scars from the points of these tools. Moreover, the use of triangular supports was indicated to represent the familiar north-south divide in China; their adoption apparently radiated outwards from kilns of the central Hebei province. L shaped step setters were noted to be exclusive Liao SJY and GWYC kiln tools for high-fired white-glazed porcellaneous bowls and dishes, which were influenced by the Xing and Ding Kilns of northern China. As for kiln structures it was shown that most Liao kilns were hemispherical mantou kilns, a type traditional in North China, with an eponymous steamed bun shape.

Chapter 6 contained a tentative chronological study of Liao ceramics, initially introducing four possible ways of a temporal classification. Based on the analytical results of the former chapters, I divided the development of Liao ceramics into three periods and five phases, i.e. the Early period from AD 907 to AD 969 which falls into two phases: Phase (907-926) and Phase (926-969); the Middle period from AD 970 to AD 1055 which is further divided into three phases: Phase (970-982), Phase (982-1031), and Phase (1031-1055); and the Late period from AD 1055 to AD 1125. Different characteristics of different developing phases were subsequently illustrated. I defined the Early period as the original development stage of Liao ceramics, with Phase marking the early establishment of Liao, when the main products were unglazed potteries of jars and long-neck bottles, and Phase representing the period of birth of Liao's glazed ceramics. It was illustrated that on the one hand the quantity of unglazed potteries decreased rapidly, while the numbers of glazed wares on the other hand increased sharply. It was further observed that while the quantity and variety of ceramics was small, the vessel shapes were elegant and the ceramic quality fine. Moreover, it was noted that white wares and green-glazed wares occupied the dominant numeral position and that patterned decorations were not popular during the Early period. Particular attention was paid to the most well-renowned ceramic form of the time, the bag-shaped pilgrim flask. An imitation of nomads' leather bags, it was classified into two groups, the larger one characterized by a slab handle, the other by a loop handle. General features of bag-shaped flasks were also listed, for instance a plump and squat body as well as applied raised ridges, which indicate a close imitation of the leather prototype. The Middle period of the development of Liao ceramics was marked

as the boom age during which the ceramics' forms, varieties, and decorations were more plentiful than in the Early Liao, and accordingly were also discovered in greater numbers. Phase was then identified as the advance of the period of prosperity of Liao's ceramic production, Phase as its most thriving stage, and Phase as the beginning of the decline of the boom years. In summary, a variety of shapes was quoted as the most notable feature of Middle Liao ceramics, and a great enhancement of the interest in decorations compared with the Early Liao was emphasized, which resulted in higher amounts of technically more complicated ornaments. Finally, the body varieties commonly attributed to the Middle period were listed to be pinkish earthenwares, grayish or yellowish stonewares, and white porcelain wares. The Late Liao was identified as an age of sudden change in the development of Liao ceramics. It was pointed out that in spite of the rapid decline of Liao political power, Liao ceramics continued to be produced and even reached a new and unique stage of development: the numbers of Khitan-style vessels decreased sharply, whereas the traditional Chinese-style ceramics increased rapidly. Furthermore, it was noted that most ceramic shapes were simplified, for instance the bag-shaped pilgrim flasks which were reduced to the appearance of group 2, with a loop-handle, a round, elongate body and a ring-foot. sArchaeological information was quoted to show that an interest in decoration, which had already been increasing during the Middle Liao, became even more pronounced in the Late period. The most prominent feature of this period was identified to be the fact that polychrome lead-glazed decorations assumed the dominant position over monochrome glazes, and that accordingly three-color-glazed earthenware is the most characteristic ceramic variety of the Late Liao. Finally, transpired that many of the period's vessels are more densely and complexly decorated than the mainly incised or carved Early and Middle Liao wares, producing entirely new effects.

Ultimately, this study demonstrates that recently obtained archaeological material has helped to provide a more comprehensive understanding of Liao ceramics, solving many major problems relating to the field.

GLOSSARY OF CHINESE CHARACTERS

PERSONAL NAMES

Abaoji	阿保机
Aguda	阿骨打
An Lushan	安禄山
Ananda	阿难
Balashagun	八拉沙衮
Fancui	范粹
Xiao Shilu	萧室鲁
Zhigu	质古
Geng Yanyi	耿延毅
Geng Zhixin	耿知新
Han Xiang	韩相
Han Yi	韩佚
HusiWoluduo	虎思斡鲁朵
Kasyapa	迦叶
Kuge	窟哥
Li Jinzhong	李尽忠
Li Shihuo	李失活
Liu Chengsui	刘承遂
Liu Hu	刘祐
Liu Riyong	刘日咏
Liu Yujie	刘宇杰
Ma Zhiwen	马直温
Qin Dechang	秦德昌
Qu Chulü	屈出律
Shang Wei	尚喙
Tang Yulin	汤玉麟
Wang Yue	王悦
Wang Ze	王泽
Wu Zetian	武则天
Xiao Beiteben	萧孛特本
Xiao Dewen	萧德温
Xiao Fujun	萧府君
Xiao Jin	萧仅
Xiao Paolu	肖袍鲁
Xiao Shenwei	萧慎微
Xiao Xiaozhong	萧孝忠
Yelü Abaoji	耶律阿保机
Yelü Deguang	耶律德光
Yelü Hongji	耶律洪基
Yelü Jing	耶律璟
Yelü Longxu	耶律隆绪
Yelü Ruan	耶律阮

Yelü Xian	耶律贤
Yelü Xiuge	耶律休哥
Yelü Yanning	耶律延宁墓
Yelü Yanxi	耶律延禧
Yelü Zhilugu	耶律直鲁古
Yelü Zongzhen	耶律宗真
Yelü Dashi	耶律大石
Zhang Gongyou	张恭诱
Zhang Kuangzheng	张匡正
Zhang Shiben	张世本
Zhang Shiqing	张世卿
Zhang Wenzao	张文藻
Zhao Dejun	赵德钧
Zhao Kuangyu	赵匡禹
Zheng Ke	郑恪
Zhuluke	殊禄科
Xiao Tang	萧闳

PLACE NAMES

Altai Mountain	阿尔泰山
Aluke'erqin Banner	阿鲁科尔沁旗
Anxinzhuang	安辛庄
Anyang	安阳
Anye	安业
Aobaoenge'er	敖包恩格尔
Aohan Banner	敖汉旗
Babaoshan	八宝山
Bailongdui Desert	白龙堆沙漠
Baitazi	白塔子
Baixintun	白辛屯
Baiyintala	白音塔拉
Baiyüdu	白玉都
Balashagun	巴拉沙衮
Balin Left Banner	巴林左旗
Balin Right Banner	巴林右旗
Banzhijian River	半支箭河
Baoshan	宝山
Batuyingzi	巴图营子
Bayingele	白音戈勒
Bazhalaga	巴扎拉噶
Beijing	北京
Beiling	北岭
Beipiao	北票
Beizhengcun	北郑村

Bohai	渤海	Faku	法库
Boluocheng	波罗城	Fangshan	反山
Boluochi	波罗赤	Fanjiatun	范家屯
Caiyuanzi	菜园子	Fanzhangzi	范杖子
Chaganba	查干坝	Fengning	丰宁
Chaganwusu	查干勿苏	Fengtai	丰台
Chaidama	差大马	Fulaer	富拉尔
Chaidamu	柴达木	Fuxin	阜新
Changgoumen	厂沟门	Gangguantun	江官屯
Changsha	长沙	Gangwayao	缸瓦窑村
Chanyuan	澶渊	Gansu	甘肃
Chaoketudongshan	朝克图东山	Goryeo	高丽
Chaoyang	朝阳	Goucun	沟村
Chayou front Banner	察右前旗	Goumencun	沟门村
Chengde	承德	Goumenzi	沟门子
Chenggou	程沟	Guangdegong	广德公
Chenzhuang	陈庄	Guangdong	广东
Chifeng	赤峰	Guduhe	古都河
Cizhou	磁州	Guishan	龟山
Dading	大定	Guojiatun	郭家屯
Daguantun	大官屯	Gushanzi	古山子
Daguben	大固本	Guyingzi	孤营子
Dahenggou	大横沟	Hadayingge	哈达英格
Daiqintala	代钦塔拉	Hailiban	海力版
Dalaming'an	达拉明安	Shangdu	商都
Dalinzi	大林子	Hansumu	罕苏木
Dantu	丹徒	Haoqianyingzi	豪欠营子
dao	道	Haotehua	浩特花
Dao'erqige	道尔其格	Haoxiumaodu	好秀毛都
Dasanjia	大三家	Hebei	河北
Dashalitu	大沙力土	Heilongjiang	黑龙江
Dashata	大沙塔	Helinge'er	和林格尔
Datong	大同	Henan	河南
Daxigou	大西沟	Hepingcun	和平村
Daxing	大兴	Hepingyingzi	和平营子
Dayingzi	大营子	Heshanxiang	合山乡
Dayu alley	大玉胡同	Hongmiaozi	红庙子
Dazhangzi	大杖子	Houliudongtun	后刘东屯
Dongguanbei	东关北	Houtougou	猴头沟
Dongjing	东京	Huairan	怀仁
Dongping	东平	Huang River	潢水
Dongwujiazi	东五家子	Huangdu	潢都
Dujiawopu	杜家窝铺	Huanghuagou	黄花沟
Erbadi	二八地	Huluncun	囡囡村
Ercun	二村	Hunan	湖南
Erhun	鄂尔浑河	Hunyuan	浑源
Erlinchang	二林场墓	Hurenbaohe	呼仁宝和墓

Husinao	呼斯淖	Mukden	奉天
Inner Mongolia	内蒙古	Mutouchengzi	木头城子
Jehol province	热河省	Mutouyinzi	木头营子
Ji county	薊县	Nailingao	奈林稿
Jianchang	建昌	Naiman banner	奈曼旗
Jiangsu	江苏	Nanjing	南京
Jiangxi	江西	Nanlinzi	南林子
Jianping	建平	Nanzaoliyingzi	南皂力营子
Jianshan	尖山	Ningcheng	宁城
Jiefangyingzi	解放营子	Paoshouying	炮手营
Jiezhuang	界庄	Pianlianchengzhi	偏脸城址
Jilin	吉林	Pijianggou	皮匠沟
Jinshifang	锦什坊	Pingquan	平泉
Jinxi	锦西	Qian'an	迁安
Jinzhou	锦州	Qianchuanghu	前窗户墓
Jizhangzi	季杖子	Qianguo	前郭
Kalaqin Banner	喀喇沁旗	Qianhaizi	前海子
Kangping	康平	Qianwagou	前瓦沟
Kazuo	喀左	Qianwulibuge	前勿力布格
Kelulun	克鲁伦河	Qijiazi	七家子
Keshiketeng Banner	克什克腾旗	Qinghemem	清河门
Keyou Front Banner	科右前旗	Qinglongshan	青龙山
Keyou Middle Banner	科右中旗	Qingyundian	青云店
Keyou Rear Banner	科右后旗	Qingzhou	庆州
Kazuo Rear Banner	喀左后旗	Qiqihaer	齐齐哈尔
Koupuyinzi	扣卜营子	Qiyi	七一村
Kulun Banner	库伦旗	Qujiagou	曲家沟
Lamagou	喇嘛沟	Sanbahuo	三把火村
Langfang	廊坊	Sangoucun	三沟村
Laoha River	老哈河	Sanhezhuanchang	三合砖场
Liaoning	辽宁	Sanjiaxiang	三家乡
Liaoyang	辽阳	Sanjiazi	三家子
Libeibao	李贝堡	Sanshan	三山乡
Lincheng	临城	Selenge	色楞格河
Lindong	林东	Shajiyao	沙家窑墓
Lingyuan	凌源	Shangjiagou	商家沟
Linhuang	临潢	Shangjing	上京
Linxi	林西	Shanglu	上芦
Lishu	梨树	Shangshaoguo	上烧锅
Longhua	隆化	Shangyi	尚义
Longquanwu	龙泉务	Shanxi	山西
Luanping	滦平	Shanzuizi	山嘴子
Luotuoling	骆驼岭	Shaoguoyinzi	烧锅营子
Maiwanggou	埋王沟	Shazigou	沙子沟
Majia	马家	Shenyang	沈阳
Mentongou	门头沟	Shichengxian	石城县
Miyun	密云	Shijianfang	十间房

Shijingshan	石景山	Xinfengzhuanchang	新丰砖厂
Shira Muren	西拉木伦河	Xing'an Mountains	兴安岭
Shuangliao	双辽	Xinghe	兴和
Shuanglonggang	双龙岗	Xinglonggou	兴隆沟
Shuangsheng	双胜	Xinglongzhuang	兴隆庄
Shuiquan	水泉	Xinjiang	新疆
Shunyi	顺义	Xinlincun	新林村
Sifangcheng	四方城	Xinmin	新民
Songmo	松漠	Xinnong	新农
Tahuchengzhi	塔虎城址	Xishancun	西山村
Taizi River	太子河	Xishangen	西山根
Tangkuaidi	唐块地	Xiyongfengcun	西永丰村
Tianjin	天津	Xuanhua	宣化
Tianshankou	天山口	XYFC	西永丰墓
Tiejiangyinzi	铁匠营子	Yanjing	燕京
Tizimiao	梯子庙	Yanlanwa	燕兰洼
Tongliao	通辽	Yanyun	燕云
Tu River	土河	Yanzhou	燕州
Tuquan	突泉	Yaogoumen	窑沟门
Wulibuge	勿力布格	Yebaishou	叶柏寿
Wangfengou	王坟沟	Yemaotai	叶茂台
Wangjiadian	王家店	Yi County	易县
Wanjinshan	万金山	Yingfangcun	营房村墓
Wenduoeraoruishan	温多尔敖瑞山	Yinwogou	银窝沟
Wengniute Banner	翁牛特旗	Yongding River	永定河
Wenjiatun	温家屯	Yongdingmen	永定门
Wohuwan	卧虎湾	Yongqing mausoleum	永庆陵
Wudaogoumen	五道沟门	Yuezhangzi	岳杖子
Wujianfang	五间房	Zhaigezhuang	翟各庄
Wujiazi	五家子	Zhaitang	斋堂
Wulanhada	乌兰哈达墓	Zhalute Banner	扎鲁特旗
Xiabali	下巴里	Zhangjiayao	张家窑
Xianfeng	先锋	Zhangjiayingzi	张家营子
Xiaohada	小哈达	Zhangkang	张扛
Xiaojigou	小吉沟	Zhangwu	彰武
Xiaoliuzhangzi	小刘仗子	Zhaodong	肇东
Xiaonuri	小努日	Zhaoduba	召都巴
Xiaopijianggou	小皮匠沟	Zhejiang	浙江
Xiaoshuiyu	小水峪	Zhelimu Union	哲里木盟
Xiaotangtugou	小塘土沟	Zhenzhou	镇州
Xicheng district	西城区	Zhongjing	中京
Xidianzi	西甸子	zhou	州
Xigushan	西孤山	Zhouzhangzi	周杖子
Xijin	析津	Zhunge'er	准格尔
Xijing	西京	Zuzhou	祖州
Xilao village	西涝村		
Xindi	新地		

DYNASTY NAMES

Eastern Han	东汉 (25-220)
Northern Wei	北魏 (386-534)
Five Dynasties	五代 (907-960)
Houjin	后晋 (939-946)
Jin	金 (1115-1234)
Liao	辽 (907-1125)
Northern Qi	北齐 (550-577)
Song	宋 (960-1127)
Sui	隋 (581-618)
Tang	唐 (618-907)
Yuan	元 (1271-1368)

KILNS AND WARES OF CHINA PROPER

Cizhou	磁州窑
Ding	定窑
Qingbai ware	青白瓷
Ru	汝窑
Xicun	西村窑
Xing	邢窑
Yaozhou	耀州窑
Yue	越窑

INSCRIPTIONS

Bao Zhu	包逐
guan	官
Li Zao	礼造
Liu	刘
xinguan	新官
Zhai Xiu	翟秀
Zhao	赵

MATERIAL AND MINERAL NAMES

Bainiantu	白粘土
Ci	瓷
Nian Ganzi Tu	粘矸子土
Tao	陶
Tujieshi	土结石
Yelashi	叶腊石
Ying Ganzi Tu	硬矸子土

TRIBES AND CLANS

Dahe	大贺
Donghu	东胡
Naiman	乃蛮
Tujue	突厥

Xi	奚
Yaonian	遥辇
Yelü	耶律
Halaqidan	哈喇契丹

REIGN TITLES

Baoda	保大	1121-1125
Baoning	保宁	969-979
Chongxi	重熙	1032-1055
Da'an	大安	1085-1095
Dakang	大康	1075-1085
Huitong	会同	938-947
Jingfu	景福	1031-1032
Kaitai	开泰	1012-1021
Qianheng	乾亨	982
Qiantong	乾统	1101-1110
Qingning	清宁	1055-1064
Shence	神册	916-922
Shouchang	寿昌	1095-1101
Shoulong	寿隆	1095-1101
Taiping	太平	1021-1031
Tianlu	天禄	947-951
Tianqing	天庆	1111-1120
Tianxian	天显	927-938
Tianzan	天赞	922-926
Tonghe	统和	983-1012
Xianyong	咸雍	1065-1075
Yingli	应历	951-969

TITLES

Ciyao guan	磁窑官
Daozong	道宗
Dudu	都督
Empress Chengtian	承天皇后
Empress Xiao	萧太后
guan yao guan	官窑官
Jin Guo Furen	晋国夫人
Jingzong	景宗
kehan	可汗
Muzong	穆宗
Shengzong	圣宗
Shizong	世宗
Taizong	太宗
Taizu	太祖
Tianzuo	天祚帝
Yongle	永乐公主
Xingzong	兴宗

VESSEL NAMES

cockscorb bottle	鸡冠壶
Di	笛
Kui	魁
kundikas	净瓶
Longbingwan	龙柄碗
Longbingxi	龙柄洗
Madenghu	马镫壶
Mannenke	万年罐
meiping	梅瓶
Nuan Pen	暖盆
Pinanghu	皮囊壶
Shao	哨
Tuohu	唾壶
Tuoyu	唾盂
Xun	埴
Zhadou	渣斗
Zhihu	执壶
Zhuhu	注壶
Zhuzi	注子

OTHERS

Chanyuan Treaty	澶渊之盟
guan yao	官窑
Han people	汉人
Han style	汉风格
Jurchen	女真
Khitan	契丹
Khitan style	契丹风格
makara	摩羯
Manchurian	满族
Mangkou	芒口
mantou kiln	馒头窑
Marbled ware	绞胎器
mingqi	明器
mudan	牡丹
Qara Khitai	西辽
Qara-Khitan	西辽
sancai	三彩
Sassanian	萨珊
shaoyao	芍药
Yuanfengtongbao	元丰通宝

ABBREVIATIONS

TOMBS

ABEGE	敖包恩格尔墓	EBD1	二八地 M1
AXZ	安辛庄	EBD2	二八地 M2
AYC	安业村墓	ECM	二村墓
BL1	北岭 M1	ELC	二林场墓
BL3	北岭 M3	FJTG D	范家屯沟东墓
BL4	北岭 M4	FJTGX	范家屯沟西墓
BLC	波罗赤墓	FLE	富拉尔墓
BS1	宝山 M1	FMM	驹马墓
BTYZ	巴图营子墓	FTM	丰台墓
BTZM	白塔子墓	FZZ	范杖子墓
BXT	白辛屯墓	GCM	沟村墓
BYD	白玉都墓	GDG	广德公墓
BYTL	白音塔拉墓	GDH1	古都河墓
BZLG	巴扎拉噶墓	GJT	郭家屯墓
CDM	柴达木墓	GMC	沟门村墓
CDMM	差大马墓	GMZ	沟门子墓
CGB11	查干坝 M11	GS1	龟山 M1
CGC	程沟村墓	GSH2	古都河 M2
CGGZ	陈国公主墓	GSM	郭氏墓
CGM	厂沟门墓	GSZ1	古山子 M1
CGWS	查干乌苏墓	GSZ2	古山子 M2
CKTDS4	朝克图东山 M4	GY Y	耿延毅墓
CYZ	菜园子墓	GZX	耿延毅墓
CZ1	陈庄 M1	HRBH	呼仁宝和墓
DEQG	道尔其格墓	HLB1	海力板 M1
DGB	大固本墓	HLC1	囡囡村 M1
DGBM	东关北墓	HLDT1	后刘东屯 M1
DHB	大河北墓	HLDT2	后刘东屯 M2
DHG1	大横沟 M1	HMZ	红庙子墓
DJWP	杜家窝铺	Hoard SGC	三沟村窖藏
DLMA	达拉明安墓	HPC	和平村墓
DLZ	大林子	HPYZ1	和平营子 M1
DPC	东平村墓	HQYZ6	豪欠营子 M6
DQTL1	代钦塔拉 M1	HQYZ9	豪欠营子 M9
DQTL3	代钦塔拉 M3	HSMSM	罕苏木苏木墓
DSJ	大三家墓	HSN	呼斯淖墓
DSL T1	大沙力土 M1	HSX	韩师训墓
DST3	大沙塔 M3	HSXM	合山乡墓
DWD	丁文道墓	HTH1	浩特花 M1
DXG1	大西沟 M1	HXM	韩相墓
DYHT	大玉胡同墓	HXMD	好秀毛都墓
DYZ3	大营子 M3	HYM	韩佚墓
DZZ	大杖子墓	JFYZ	解放营子
		JGFR	晋国夫人墓
		JSF	锦什坊墓

JSM	尖山墓	SJYM	沙家窑墓
JZZ	季杖子墓	SJZ	三家子墓
KL1	库伦 M1	SLC	上芦墓
KL3	库伦 M3	SLG1	双龙岗 M1
KL5	库伦 M5	SLG2	双龙岗 M2
KL6	库伦 M6	SLG3	双龙岗 M3
KPYZ1	扣卜营子 M1	SLG6	双龙岗 M6
LBB	李贝堡墓	SLG7	双龙岗 M7
LCS	刘承遂墓	SQ1	水泉 M1
LHM	刘祐墓	SSG4	上烧锅 M4
LMG	喇嘛沟墓	SWFM	尚漳符墓
LRY	刘日咏墓	SZG1	沙子沟 M1
LTL	骆驼岭墓	THCZ	塔虎城址
LYJ	刘宇杰墓	TJYZ	铁匠营子墓
MJ1	马家 M1	TZM2	梯子庙 M2
MTCZ	木头城子墓	TZM3	梯子庙 M3
MTYZ1	木头营子 M1	WDEARS	温多尔敖瑞山墓
MTYZ2	木头营子 M2	WDGM	五道沟门墓
MWG3	埋王沟 M3	WFG	王坟沟墓
MWG4	埋王沟 M4	WHW3	卧虎湾 M3
MZW	马直温墓	WHW6	卧虎湾 M6
NGF1	nagefu	WJD	王家店墓
NLZ	南林子墓	WJF	五间房墓
NZLYZ1	南皂力营子 M1	WJS1	万金山 M1
PJG1	皮匠沟 M1	WJS2	万金山 M2
PJG2	皮匠沟 M2	WJT	温家屯墓
PJG3	皮匠沟 M3	WJZ	五家子墓
PLCZ	偏脸城址	WLHD	乌兰哈达墓
PSY1	炮手营 M1	WYM	王悦墓
QCH	前窗户墓	WZM	王泽墓
QDC	秦德昌墓	XBTB	萧宇特本墓
QHM1	清河门 M1	XDM	新地墓
QHM2	清河门 M2	XDW	萧德温墓
QHM4	清河门 M4	XDZ	西甸子墓
QHZ	前海子墓	XFJ	萧府君墓
QJG1	曲家沟 M1	XFZC	新丰砖厂墓
QJG2	曲家沟 M2	XHD	小哈达墓
QJZ	七家子墓	XJM	萧仅墓
QYC	七一村墓	XLC	新林村墓
QYD1	青云店 M1	XLC5	西涝村 M5
QYD2	青云店 M2	XLG	兴隆沟墓
SBH	三把火墓	XLZ	兴隆庄墓
SFC	四方城	XLZZ1	小刘仗子 M1
SGYZ	烧锅营子墓	XLZZ2	小刘仗子 M2
SHZC	三合砖场墓	XLZZ3	小刘仗子 M3
SJF	十间房墓	XLZZ4	小刘仗子 M4
SJG1	商家沟 M1	XNRM	小努日墓

XPJG	小皮匠沟墓
XPL	肖袍鲁墓
XSC10	西山村 M10
XSC3	西山村 M3
XSC4	西山村 M4
XSC7	西山村 M7
XSC9	西山村 M9
XSG	西山根墓
XTM	萧闾墓
XTTG3	小塘土沟 M3
XTTG4	小塘土沟 M4
XXZ	萧孝忠墓
YBS	叶柏寿墓
YDM	永定门墓
YFC	营房村墓
YGM	窑沟门墓
YLQ	耶律祺墓
YLW	燕兰洼墓
LYLN	耶律延宁墓
LYLZ	耶律羽之墓
YMT2	叶茂台 M2
YMT22	叶茂台 M22
YMT3	叶茂台 M3
YMT5	叶茂台 M5
YMT7	叶茂台 M7
YMT8	叶茂台 M8
YS1	羊山 M1
YS3	羊山 M3
YWG	银窝沟墓
ZDB	召都巴墓
ZDJ	赵德钧墓
ZGY	张恭诱墓
ZGZ2	翟各庄 M2
ZJY1	张家窑 M1
ZKC1	张扛村 M1
ZKC2	张扛村 M2
ZKC3	张扛村 M3
ZKC4	张扛村 M4
ZKM	郑恪墓
ZKY	赵匡禹墓
ZKZ	张匡正墓
ZLK	硃碌科墓
ZSB	张世本墓
ZSQ	张世卿墓
ZTM	斋堂墓
ZWZ	张文藻墓

KILN SITES

BSY	宝山村西南沟窑
BYGL	白音戈勒窑
CJW	磁家务窑
DBWS	代白乌苏村南窑
DGT	大官屯窑
DSBET	东沙布尔台窑
DTY	大同窑
EMK	鹅毛口窑
GGT	江官屯窑
GWYC	缸瓦窑
HDYG	哈达英格窑
HRY	怀仁窑
JZY	界庄窑
LBYH	老白音花村南沟窑
LHY	隆化窑
LQW	龙泉务窑
NSY	南山窑
QCY	青磁窑
SJY	上京窑
SQG	水泉沟窑
SQGC	水泉沟村窑
WJY	吴家窑
WYY	碗窑村窑
XBG	小北沟窑
XJG	小吉沟窑
XSJ	小水峪窑
XYY	小峪窑
YKD	窑坑地窑

PAGODAS

Jingjuesi	净觉寺
Pagoda BZCT	北郑村塔
Pagoda CSS	崇寿寺
Pagoda CYBTGD	朝阳北塔地宫
Pagoda CYBTGT	朝阳北塔天宫
Pagoda DLS	独乐寺
Pagoda JGS	净光寺
Pagoda JJS	净觉寺
Pagoda QZBT	庆州白塔
Pagoda WGJGSLT	无垢净光舍利塔
Pagoda YXT	易县塔
Yexianta	冶仙塔

APPENDICES

TABLE 24 CHRONOLOGY OF DYNASTIC CHINA

Dynasty			Years	
Three August Ones and the Five Emperors	三皇五帝	sān huáng wǔ dì	before 2070 BC	628+
Xia Dynasty	夏	xià	2070 BC - 1600 BC	470
Shang Dynasty	商	shāng	1600 BC - 1046 BC	554
Western Zhou Dynasty	西周	xī zhōu	1046 BC - 771 BC	275
Eastern Zhou Dynasty	东周	dōng zhōu	770 BC - 256 BC	514
Traditionally divided into				
Spring and Autumn Period	春秋	chūn qiū	722 BC - 476 BC	246
Warring States Period	战国	zhàn guó	475 BC - 221 BC	254
Qin Dynasty	秦	qín	221 BC - 206 BC	15
Western Han Dynasty	西汉	xī hàn	206 BC - 9 AD	215
Xin Dynasty	新	xīn	9 - 25	16
Eastern Han Dynasty	东汉	dōng hàn	25 - 220	195
Three Kingdoms	三国	sān guó	220 - 265	45
Western Jin dynasty	西晋	xī jìn	265 - 317	52
Eastern Jin dynasty	东晋	dōng jìn	317 - 420	103
Southern and Northern Dynasties	南北朝	nán běi cháo	420 - 581	161
Sui Dynasty	隋	suí	581 - 618	37
Tang dynasty	唐	táng	618 - 907	289
Five Dynasties and Ten Kingdoms	五代十国	wǔ dài shí guó	907 - 960	53
Northern Song dynasty	北宋	běi sòng	960 - 1127	167
Southern Song dynasty	南宋	nán sòng	1127 - 1279	152
Liao Dynasty	辽	liáo	907- 1125	218
Jin dynasty	金	jīn	1115 - 1234	119
Yuan Dynasty	元	yuán	1271 - 1368	97
Ming Dynasty	明	míng	1368 - 1644	276
Qing Dynasty	清	qīng	1644 - 1911	267

TABLE 25 INDEX OF ABBREVIATIONS OF LIAO TOMBS (A-Z)

NO.	Abb. Name of tombs	Owner	Province	Banner/City /County/dis trict	Township/v illage	Period of Liao	Date (AD.)
1	ABEGE		Inner Mongolia	Balin Right Banner	Aobaoengeer	early	
2	AXZ		Beijing	Shunyi county	Anxinzhuang	middle	
3	AYC		Heilongji ang	Zhaodong city	Anye village	early	
4	BL1		Liaoning	Kazuo county	Beiling	middle	
5	BL3		Liaoning	Kazuo	Beiling	late	
6	BL4		Liaoning	Kazuo county	Beiling	middle	
7	BLC		Liaoning	Chaoyang city	Boluochi	early	
8	BS1		Inner Mongolia	Aluke'erqin Banner	Baoshan	early	923
9	BTYZ		Liaoning	Xinmin	Batuyingzi	late	
10	BTZ		Inner Mongolia	Aohan Banner	Baitazi	late	1081
11	BXT		Inner Mongolia	Keyou Front Banner	Baixintun	middle	
12	BYD		Liaoning	Fuxin city	Baiyüdu	early	
13	BYTL		Inner Mongolia	Kazuo Rear Banner	Baiyintala	middle	
14	BZLG		Inner Mongolia	Keyou Middle Banner	Bazhalaga	middle	
15	CDM		Inner Mongolia	Aluke'er qin Banner	Chaidamu	late	
16	CDMM		Liaoning	Zhangwu county	Chaidama	late	
17	CGB11		Inner Mogolia	Balin Left Banner	Chaganba	middle	
18	CGC		Liaoning	Fuxin	Chenggou village	late	

NO.	Abb. Name of tombs	Owner	Province	Banner/City /County/district	Township/village	Period of Liao	Date (AD.)
19	CGGZ	Princes of Chen and Xiao Shaoju	Inner Mongolia	Naiman banner	Qinglongshan	middle	1018
20	CGM		Hebei	Longhua county	Changgoumen	late	
21	CGWS		Inner Mongolia	Balin Right Banner	Chaganwusu	early	
22	CKTDS4		Inner Mongolia	Aluke'erqin Banner	Chaoketudongshan,Hansumusu	late	
23	CYZ		Liaoning	Lingyuan County	caiyuanzi village	early	
24	CZ1		Beijing	Changping county	Chenzhuang village	late	
25	DEQG		Inner Mongolia	Aluke'erqin Banner	Daoerqige	middle	
26	DGB		Liaoning	Fuxin city	Daguben	late	
27	DGBM		Hebei	Langfang city,Yongqing county	Dongguanbei	late	
28	DHB		Liaoning	Lingyuan county	Dahebei Township	late	1091
29	DHG1		Inner Mongolia	Aohan Banner	Dahenggou	early	
30	DJWP		Inner Mongolia	Ningcheng	Dujiawopu	middle	
31	DLMA		Inner Mongolia	Chifeng	Dalaming'an	late	
32	DLZ		Liaoning	Liaoyang city	Dalinzi	late	1096
33	DPC		Liaoning	Zhangwu	Dongping village	middle	
34	DQTL1		Inner Mongolia	Keyou Middle Banner	Daiqintala	early	

NO.	Abb. Name of tombs	Owner	Province	Banner/City /County/dis trict	Township/v illage	Period of Liao	Date (AD.)
35	DQTL3		Inner Mongolia	Keyou Middle Banner	Daiqintala	early	
36	DSJ		Liaoning	Kazuo county	Dasanjia	middle	
37	DSL1		Liaoning	Zhaowu county	Dashalitu	middle	
38	DST3		Inner Mongolia	Zhunge'er	Dashata	early	
39	DWD	Ding Wenda o	Beijing			late	1113
40	DXG1		Liaoning	Jianping county	Daxigou	middle	
41	DYHT		Beijing		Dayu alley	late	
42	DYZ3		Inner Mongolia	Chifeng	Dayingzi	middle	
43	DZZ		Liaoning	Kazuo county	Dazhangzi village	late	
44	EBD1		Inner Mongolia	Keshiketeng Banner	Erbadi	early	
45	EBD2		Inner Mongolia	Keshiketeng Banner	Erbadi	early	
46	ECM		Heilongji ang		Ercun	late	
47	ELC		Inner Mongolia	Tongliao county	Erlinchang	middle	
48	FJTGD		Inner Mongolia	Aluke'erqin Banner	Fanjiatun east	late	
49	FJTGX		Inner Mongolia	Aluke'erqin Banner	Fanjiatun west	late	
50	FLE		Heilongji ang		Fulaer	late	
51	FMM	Fuma Xiao Shilu and Zhigu	Inner Mongolia	Linxi County, Chifeng City	Dayingzi	early	959

NO.	Abb. Name of tombs	Owner	Province	Banner/City /County/dis trict	Township/v illage	Period of Liao	Date (AD.)
52	FTM		Beijing	Fengtai district		late	
53	FZZ		Inner Mongolia	Aohan Banner	Fanzhangzi	late	
54	GCM		Inner Mongolia	Balin Left Banner	Goucun village	early	
55	GDG		Inner Mongolia	Wengniute Banner	Guangdegong Township	middle	
56	GDH1		Inner Mongolia	Chifeng	Guduhe	late	
57	GJT		Inner Mongolia	Tuquan	Guojiatun	late	
58	GMC		Inner Mongolia	Wengniute Banner	Goumencun village	early	
59	GMZ		Liaoning	Chaoyang	Goumenzi	late	
60	GS1		Liaoning	Jianchang county	Guishan	late	
61	GSH2		Inner Mongolia	Chifeng	Guduhe	late	
62	GSM	Guo shi	Shanxi	Datong city		late	1109
63	GSZ1		Liaoning	Jianping	Gushanzi	late	
64	GSZ2		Liaoning	Jianping	Gushanzi		
65	GYG	Geng Yanyi	Liaoning	Chaoyang city	Guyingzi	middle	1020
66	GZX	Geng Zhixin	Liaoning	Chaoyang city	Guyingzi	middle	1026
67	HRBH		Inner Mongolia	Aoohan Banner	Hurenbaohe village	late	
68	HLB		Liaoning	Fuxin city	Hailiban	early	
69	HLC1		Hebei	Shangyi	Huluncun village	early	
70	HLDT2		Liaoning	Kangping county	Houliudongt un	early	
71	HLDT1		Liaoning	Kangping county	Houliudongt un	early	

NO.	Abb. Name of tombs	Owner	Province	Banner/City /County/district	Township/village	Period of Liao	Date (AD.)
72	HMZ		Inner Mongolia	Chifeng	Hongmiaozi	late	
73	Hoard SGC		Hebei	Chengde city	Sangoucun village	late	
74	HPC		Inner Mongolia	Linxi	Hepingcun village	middle	
75	HPYZ1		Inner Mongolia	Chifeng city	Hepingyingzi	late	
76	HQYZ6		Inner Mongolia	Chayou Front Banner	Haoqianyingzi	late	
77	HQYZ9		Inner Mongolia	Chayou Front Banner	haoqianyingzi	late	
78	HSMSM		Inner Mongolia	Aluke'erqin Banner	Hansumusumu	late	
79	HSN		Inner mongolia	Keyou behind Banner	Husinao	early	
80	HSX	Han Shixun	Hebei	Xuanhua city	Xiabali	late	1111
81	HSXM		Heilongjiang		Heshanxiang	early	
82	HTH1		Inner Mongolia	Zhalute Banner	Haotehua	middle	
83	HXM	Han Xiang	Hebei	Qian'an	Shanglu villiage	middle	1017
84	HXMD		Inner Mongolia	Aluke'erqin Banner	Haoxiumaodu	late	
85	HYM	Han Yi	Beijing	Shijingshan district	Babaoshan	middle	1011
86	JFYZ		Liaoning	Jianping and Xinmin	Jiefangyingzi	late	
87	JGFR	Dame of Jin (Jin Guo Furen)	Liaoning	Fuxin city		middle	1038
88	JSF		Beijing	Xicheng district	Jinshifang road	late	
89	JSM		Inner Mongolia	Xinhe	Jianshan	late	

NO.	Abb. Name of tombs	Owner	Province	Banner/City /County/district	Township/village	Period of Liao	Date (AD.)
90	JZZ		Liaoning	Beipiao county	Jizhangzi	middle	
91	KL1		Inner Mongolia	Kulun Banner	Wulibuge village	late	1080
92	KL3		Inner Mongolia	Kulun Banner		middle	
93	KL5		Inner Mongolia	Kulun Banner	Qianwulibug e	late	
94	KL6		Inner Mongolia	Kulun Banner	Qianwulibug e	late	
95	KPYZ1		Liaoning	Beipiao	Koupuyinzi	early	
96	LBB		Liaoning	Faku county	Libeibao	early	
97	LCS	Liu Chengsui	Shangxi	Datong city		late	1119
98	LHM	Liu Hu	Inner Mongolia	Aohan Banner		late	1099
99	LMG		Inner Mongolia	Aohan Banner	Lamagou	late	
100	LRY	Liu Riyong	Liaoning	Chaoyang city		middle	1046
101	LTL		Jilin	Shuangliao	Luotuoling	late	
102	LYJ	Liu Yujie	Liaoning	Chaoyang city		middle	1000
103	MJ1		Liaoning	Zhangwu county	Majia	late	
104	MTCZ		Liaoning	Chaoyang	Mutouchengzi	late	
105	MTYZ1		Inner Mongolia	Zhelimu Union,	Mutouyinzi Village, Nailingao Township	early	
106	MTYZ2		Inner Mongolia	Zhelimu Union,	Mutouyinzi Village, Nailingao Township	early	

NO.	Abb. Name of tombs	Owner	Province	Banner/City /County/district	Township/village	Period of Liao	Date (AD.)
107	MZW	Ma Zhiwen couples	Beijing	Daxing county		late	1113
108	NGF1		Inner Mongolia	Chifeng city	Nagefu	late	
109	NLZ		Liaoning	Liaoyang	Nanlinzi	late	
110	NZLYZ1		Liaoning	Fuxin city	Nanzaoliying zi	early	
111	Pagoda BZCT	Bei Zhengcun	Beijing	Fangshan county	Beizhengcun village	middle	1051
112	Pagoda CSS	Chongshou temple	Liaoning	Shenyang city		late	1108
113	Pagoda CYBTDG	Underground palace of north pagoda	Liaoning	Chaoyang city		middle	1044
114	Pagoda CYBTTG	Celestial palace of north pagoda	Liaoning	Chaoyang city		middle	1043
115	Pagoda DLS	Dulesi temple	Tianjin	Ji county		late	1058
116	Pagoda JGS	Jing Guang Monastery	Beijing	Shunyi county		middle	1014
117	Pagoda JJS	Foundation of pagoda in Jingjuesi temple	Hebei	Yi county		late	1115
118	Pagoda QZBT	Baita	Inner Mongolia	Balin Right banner	Qingzhou	middle	1049

NO.	Abb. Name of tombs	Owner	Province	Banner/City /County/district	Township/village	Period of Liao	Date (AD.)
119	Pagoda WGJGSL T	Wugou Jingguang Sheli Ta	Liaoning	Shenyang city		middle	1044
120	Pagoda YXT		Beijing	Miyun county	Yexianta	late	
121	PJG1		Inner Mongolia	Aohan Banner	Pijiangou	middle	
122	PJG2		Inner Mongolia	Aohan Banner	Pijianggou	late	
123	PJG3		Inner Mongolia	Aohan Banner	Pijianggou	late	
124	PLCZ		Jilin	Lishu	Pianlianchengzi	late	
125	PSY1		Liaoning	Jianping county	Paoshouying	late	
126	QCH		Liaoning	Chaoyang city	Qianchuanghu	middle	
127	QDC	Qin Dechang	Liaoning	Jianping county	Sanjiaxiang	late	1075
128	QHM1	unknown	Liaoning	Yi County	Qinghemmen	middle	1044
129	QHM2	Xiao Shenwei	Liaoning	Yi county	Qinghemmen	late	1057
130	QHM4		Liaoning	Yi County	Qinghemmen	middle	
131	QHZ		Hebei	Shangdu	Qianhaizi village	late	
132	QJG1		Inner Mongolia	Chifeng city	Qujiagou	late	
133	QJG2		Inner Mongolia	Chifeng city	Qujiagou	late	
134	QJZ		Liaoning	Fuxin city	Qijiazi	early	
135	QYC		Inner Mongolia	Linxi	Qiyi village	early	
136	QYD1		Beijing	Daxing county	Qingyundian	late	

NO.	Abb. Name of tombs	Owner	Province	Banner/City /County/district	Township/village	Period of Liao	Date (AD.)
137	QYD2		Beijing	Daxing county	Qingyundian	late	
138	SBH		Inner Mongolia	Chifeng city	Sanbahuo	late	
139	SFC		Inner Mongolia	Balin Left Banner	Sifangcheng	late	1066
140	SGYZ		Liaoning	Jianping city	Shaoguoyinzi	late	
141	SHZC		Heilongjiang	Qiqihaer	Sanhezhuanchang, Meiersi	late	
142	SJF		Inner Mongolia	Chifeng city	Shijianfang	late	
143	SJG1		Liaoning	Chaoyang city	Shangjiagou	middle	1002
144	SJYM		Heilongjiang		Shajiayao	early	
145	SJZ		Liaoning	Lingyuan county	Sanjiazi township	late	
146	SLC		Hebei	Qian'an	Shanglu village	middle	
147	SLG1		Inner Mongolia	Keyou Middle Banner	Shuanglonggang	early	
148	SLG2		Inner Mongolia	Keyou Middle Banner	Shuanglonggang	early	
149	SLG3		Inner Mongolia	Keyou Middle Banner	Shuanglonggang	early	
150	SLG6		Inner Mongolia	Keyou Middle Banner	Shuanglonggang	middle	
151	SLG7		Inner Mongolia	Keyou Middle Banner	Shuanglonggang	middle	
152	SQ1		Liaoning	Beipiao County	Shuiquan	middle	
153	SSG4		Inner Mongolia	Kalaqin Banner	Shangshaoguo	middle	

NO.	Abb. Name of tombs	Owner	Province	Banner/City /County/district	Township/village	Period of Liao	Date (AD.)
154	SWFM	Shang Wei	Inner Mongolia	Nicheng city	Zhouzhangzi	late	1099
155	SYZ1		Inner Mongolia	Chifeng city	Shiyinzi	late	
156	SYZ2		Inner Mongolia	Chifeng city	Shiyinzi	late	
157	SZG1		Inner Mongolia	Aohan banner	Shazigou	early	
158	THCZ		?	Qianguo	Tahuchengzhi	late	
159	TJYZ		Inner Mongolia	Ningcheng	Tiejiangyinzi	late	
160	TJYZM		Liaoning	Beipiao	Taijiyingzi	late	
161	TZM2		Liaoning	Fuxin	Tizimiao	middle	
162	TZM3		Liaoning	Fuxin	Tizimiao	middle	
163	WDEARS		Inner Mongolia	Aluke'erqin Banner	Wenduoeraoruishan	late	
164	WDGM		Hebei	Fengning county	Wudaogoumen	middle	
165	WFG		Liaoning	Chaoyang city	Wangfengou village, Dongwujiazi township	late	
166	WHW3		Shanxi	Datong city	Wohuwan	late	1109
167	WHW6		Shanxi	Datong city	Wohuwan	late	1093
168	WJD		Inner Mongolia	Chifeng city	Wangjiadian	late	
169	WJF		Inner Mongolia	Linxi	Wujianfang	early	
170	WJS1		Inner Mongolia	Aluke'erqin Banner	Wanjinshan	late	
171	WJS2		Inner Mongolia	Aluke'erqin Banner	Wanjinshan	late	
172	WJT		Liaoning	Lingyuan county	Wenjiatun	late	
173	WJZ		Liaoning	Fuxin city	Wujiazi	late	

NO.	Abb. Name of tombs	Owner	Province	Banner/City /County/district	Township/village	Period of Liao	Date (AD.)
174	WLHD		Inner Mongolia	Aluke'er qin Banner	Wulanhada	late	
175	WYM	Wang Yue	Liaoning	Kazuo county, Chaoyang City		middle	1005
176	WZM	Wang Ze	Beijing	Fengtai district		middle	1053
177	XBTB(MWG4)	Xiao Beiteben	Inner Mongolia	Ningcheng county, Chifeng city	Maiwanggou	late	1081
178	XDM		Inner Mongolia	Chifeng city	Xindi	late	
179	XDZ		Heilongjiang		Xidianzi	middle	
180	XFJ	Xiao Fujun	Inner Mongolia	Ningcheng county, Chifeng city	Yuezhangzi	late	1072
181	XFZC		Heilongjiang		Xinfengzhuan chang	early	
182	XHD		Inner Mongolia	Linxi	Xiaohada	middle	
183	XJM	Xiao Jin	Liaoning	Fuxin city		middle	1029
184	XJG		Hebei	Pingquan county	Xiaojigou	middle	
185	XLC		Inner Mongolia	Aluke'erqin Banner	Xinlincun village	late	
186	XLC5		Liaoning	Chaoyang city	Xilao village	late	
187	XLG		Liaoning	Kazuo	Xinglonggou	late	
188	XLZ		Inner Mongolia	Chifeng city	Xinglongzhuan g	late	
189	XLZZ1		Inner Mongolia	Ningcheng County	Xiaoliuzhang zi	late	
190	XLZZ2		Inner Mongolia	Ningcheng County	Xiaoliuzhang zi	late	
191	XLZZ3		Inner Mongolia	Ningcheng County	Xiaoliuzhang zi	late	

NO.	Abb. Name of tombs	Owner	Province	Banner/City /County/district	Township/village	Period of Liao	Date (AD.)
192	XLZZ4		Inner Mongolia	Ningcheng County	Xiaoliuzhang zi	late	
193	XLZZ5		Inner Mongolia	Ningcheng	Xiaoliuzhang zi	late	
194	XNRM		Inner Mongolia	Kazuo middle Banner	Xiaonuri	middle	
195	XPJG		Hebei	Fengning county	Xiaopijianggou	late	
196	XPL	Xiao Paolu	Liaoning	Faku county		late	1090
197	XSC10		Inner Mongolia	Tuquan	Xishancun village	late	
198	XSC3		Inner Mongolia	Tuquan	Xishancun village	late	
199	XSC4		Inner Mongolia	Tuquan county	Xishancun village	late	
200	XSC7		Inner Mongolia	Tuquan	Xishancun village	late	
201	XSC9		Inner Mongolia	Tuquan	Xishancun village	late	
202	XSG		Liaoning	Kazuo county	Xishangen	late	
203	XDW	Xiao Dewen	Liaoning	Fuxin city		late	1075
204	XTM(MWG3)	Xiao Tang	Inner Mongolia	Ningcheng county, Chifeng city	Maiwanggou	late	1070
205	XTTG3		Inner Mongolia	Ningcheng	Xiaotangtugou	middle	
206	XTTG4		Inner Mongolia	Ningcheng	Xiaotangtugou	late	
207	XXZ	Xiao Xiaozhong	Liaoning	Jinxi county	Xigushan	late	1089
208	XYFC		Hebei	Langfang city	xiyongfengcun	late	
209	YBS		Liaoning	Jianping	Yebaishou	early	

NO.	Abb. Name of tombs	Owner	Province	Banner/City /County/district	Township/village	Period of Liao	Date (AD.)
210	YDM		Beijing	Fengtai district	Yongdingmen	late	
211	YFC		Hebei	Ji county	Yingfangcun	middle	
212	YGM		Inner Mongolia	Chifeng city	Yaogoumen	late	
213	YLQ	Yelü Qi	Inner Mongolia	Aluke'erqin Banner		late	1108
214	YLW		Liaoning	Lingyuan county	Yanlanwa	late	
215	YLYN	Yelü Yanning	Liaoning	Chaoyang city		middle	986
216	YLYZ	Yelü Yuzhi and Chonggun	Inner Mongolia	Aluke'erqin Banner	Hansumu	early	942
217	YMT2		Liaoning	Faku county	Yemaotai	late	
218	YMT22		Liaoning	Faku county	Yemaotai	middle	
219	YMT3		Liaoning	Faku county	Yemaotai	late	
220	YMT5		Liaoning	Faku county	Yemaotai	middle	
221	YMT7		Liaoning	Faku county		middle	977
222	YMT8		Liaoning	Faku county	Yemaotai	late	
223	YS1		Inner Mongolia	Aohan Banner	Yangshan village	late	
224	YS3		Inner Mongolia	Aohan Banner	Yangshan village	late	
225	YWG		Hebei	Luanping county	Yinwogou	middle	
226	ZDB		Liaoning	Chaoyang	Zhaoduba	early	
227	ZDJ	Zhao Dejun	Beijing			early	958

NO.	Abb. Name of tombs	Owner	Province	Banner/City /County/dis trict	Township/v illage	Period of Liao	Date (AD.)
228	ZGY	Zhang Gongyo u	Hebe	Xuanhua city	Xiabali	late	1117
229	ZGZ2		Hebei	Langfang city	Zhaigezhuan g	late	
230	ZJY1		Liaoning	Jianping city	Zhangjiayao	early	
231	ZKC1		Liaoning	Jinzhou city	Zhangkang village	early	
232	ZKC2		Liaoning	Jinzhou city	Zhangkang village	middle	
233	ZKC3		Liaoning	Jinzhou city	Zhangkangcu n	middle	
234	ZKC4		Liaoning	Jinzhou city	Zhangkang village	early	
235	ZKM	Zheng Ke	Liaoning	Jianping county		late	1090
236	ZKY	Zhao Kuangy u	Liaoning	Chaoyang city		late	1060
237	ZKZ	Zhang Kuangz heng	Hebei	Xuanhua	Xiabali	late	1093
238	ZLK		Liaoning	Jianping city	zhuluke	early	
239	ZSB	Zhang Shiben couples	Hebei	Xuanhua city	Xiabali	late	1115-114 4
240	ZSQ	Zhang Shiqing	Hebe	Xuanhua city	Xiabali	late	1116
241	ZTM	unknow n	Beijing		Zhaitang	late	1111
242	ZWZ	Zhang Wenzao	Hebei	Xuanhua	Xiabali	late	1093

TABLE 26 INDEX OF ABBREVIATIONS OF LIAO KILN SITES (A-Z)

NO.	Abb. Name of tombs	Province	Banner/City	County/Township	village
1	BSY	Inner Mongolia	Aluke'erqin Banner	Dongshabu'ertai	Baoshan
2	BYGL	Inner Mongolia	Balin left Banner	Hadaying'ge	Baiyingele
3	CJW		Beijing	Fangshan	Cijiawu
4	DBWS	Inner Mongolia	Aluke'erqin Banner	Dongshabu'ertai	Daibaiwusu
5	DGT	Liaoning	Fushun		Daguantun
6	DSBET	Inner Mongolia	Aluke'erqin Banner	Dongshabu'ertai	
7	DTY	Shanxi	Datong City		
8	EMK	Shanxi	Datong City	Huairan	Emaokou
9	GGT	Liaoning	Liaoyang City		Gangguantun
10	GWYC	Inner Mongolia	Chifeng City	Houtougou	Gangwayao
11	HDYG	Inner Mongolia	Balin left Banner	Hadaying'ge	West hill
12	HRY	Shanxi	Datong City	Huairan	
13	JZY	Shanxi	Datong City	Hunyuan	Jiezhuang
14	LHY	Hebei	Chengde City	Longhua	
15	LQW		Beijing	Mentougou	Longquanwu
16	NSY	Inner Mongolia	Balin left Banner	Lindong	Nanshan

NO.	Abb. Name of tombs	Province	Banner/City	County/Township	village
17	QCY	Shanxi	Datong City		Qingciyao
18	SJY	Inner Mongolia	Balin left Banner	Lindong	Linhuangfu
19	SQG	Inner Mongolia	Chifeng City	Houtougou	Shuiquangou
20	SQGC	Inner Mongolia	Aluke'erqin Banner	Dongshabu'ertai	Shuiquangou
21	WJY	Shanxi	Datong City	Huairan	Wujia
22	WYY	Shanxi	Datong City	Huairan	Wanyaocun
23	XBG	Inner Mongolia		Sanshan	Xiaoberigou, Xinnong
24	XSY		Beijing	Miyun	Xiaoshuiyu
25	XYY				
26	YKD	Inner Mongolia	Wengniute Banner	Shanzuizi	Yaokengdi, Huanghuagou

TABLE 27 LIST OF UNEARTHED OBJECTS AND OTHER COLLECTIONS: BAG-SHAPED PILGRIM FLASK WITH PERFORATED SLAB HANDLE

Group	Type	Body	Glaze	Amount	Unearthed From	Collected By	Date (AD)	Cat. No.
Gr.1	Aa	Porcelain	White	1	Qijiazhi tomb at Fuxin, Liaoning	Culture bureau of Fuxin, Liaoning province		Cat. 1
Gr.1	Aa	Porcelain	White	8	FMM	Inner Mongolia autonomous region museum	959	Cat. 2
Gr.1	Aa	Pinkish-buff earthenware	White	1	HLB1			Cat. 3
Gr.1	Aa	Pinkish-buff earthenware	Green	4	DQTL3			Cat. 4
Gr.1	Aa	Pinkish-buff earthenware	Green	1	Chaoyanggou M2:20, at Zhangwu, Liaoning	Zhangwushi wenwu guanlisuo		Cat. 5
Gr.1	Aa	Pinkish-buff earthenware	Green	1	Chaoyanggou M2:19, at Zhangwu, Liaoning	Zhangwushi wenwu guanlisuo		Cat. 6
Gr.1	Aa	Pinkish-buff earthenware	Green	1	Zhangjiatun M1 at Kangping, Liaoning	Tielingshi museum		Cat. 7
Gr.1	Aa	Pinkish-buff earthenware	Tee-dust Green	2	Wusuyigen tomb at Ganggensumu, Balin Left banner, Inner Mongolia	Balin Left banner museum		Cat. 8
Gr.1	Aa	Porcelain	white	1		Liaoning provincial museum	early	Cat. 9
Gr.1	Aa	Pinkish-buff earthenware	Tee-dust Green	1	a tomb at Yebaishou station, Jianping county, Liaoning	Liaoning provincial museum		Cat. 10

Group	Type	Body	Glaze	Amount	Unearthed From	Collected By	Date (AD)	Cat. No.
Gr.1	Aa	Porcelain	White	1		Beijing gugong bowuyuan		Cat. 11
Gr.1	Aa	Pinkish-buff earthenware	Green	1		Tokyo national museum		Cat. 12
Gr.1	Aa	Pinkish-buff earthenware	Green	1		Royal Ontario museum, Toronto		Cat. 13
Gr.1	Aa	Pinkish-buff earthenware	Green	1		Center of Asian Art and Culture, Avery Brundage Collection, San Francisco, California		Cat. 14
Gr.1	Aa	Pinkish earthenware	Tee-dust Green	1	Xiaowangyedi tomb at Xindi township, Aohan Banner, Inner Mogolia	Aohan banner museum		Cat. 15
Gr.1	Aa	Pinkish earthenware	Tee-dust Green	1	Huaganzigou tomb at Hao'er tu township, Balin Left banner, Inner Mongolia	Liao shangjing museum		Cat. 16
Gr.1	Aa	Pinkish earthenware	white	1	XTTG3		middle	Cat. 17
Gr.1	Aa	Pinkish earthenware	white	1	a tomb at Sanqidi village, Huajialaga township, Balin Left banner	Liaoshangjing museum, Inner Mongolia		Cat. 18

Group	Type	Body	Glaze	Amount	Unearthed From	Collected By	Date (AD)	Cat. No.
Gr.1	Aa	Pinkish earthenware	green	1		Private collection, Japan		Cat. 19
Gr.1	Aa	Pinkish earthenware	white	1	QHM4	Liaoning provincial museum	middle	Cat. 20
Gr.1	Aa	Pinkish earthenware	white	1	Hebutehada tomb at Bayanerdengsumu, Balin Right Banner, Inner Mongolia	Balin Right Banner Museum , Inner Mongolia	middle	Cat. 21
Gr.1	Aa	Pinkish earthenware	green	1		Tokyo national museum		Cat. 22
Gr.1	Aa	Pinkish earthenware	green	1	SJG1		1002	Cat. 23
Gr.1	Aa	Pinkish earthenware	green			Guan Baocong collection		Cat. 24
Gr.1	Aa	Pinkish earthenware	green	1		Guan Baocong collection		Cat. 25
Gr.1	Aa	Pinkish earthenware	green	1		Guan Baocong collection		Cat. 26
Gr.1	Aa	Pinkish earthenware	green	1	a tomb at Pingfangzi ,Kazuo county , Liaoning	Kazuo museum, Liaoning		Cat. 27
Gr.1	Aa	Pinkish earthenware	green	1	SJG1		1002	Cat. 28
Gr.1	Aa	Pinkish earthenware	green	1		Liaoning provincial museum		Cat. 29

Group	Type	Body	Glaze	Amount	Unearthed From	Collected By	Date (AD)	Cat. No.
Gr.1	Aa	Pinkish earthenware	green	1				Cat. 30
Gr.1	Aa	Pinkish earthenware	white	1		Liaoning provincial museum		Cat. 31
Gr.1	Ab	Pinkish earthenware	green	1	SZG1		early	Cat. 32
Gr.1	Ab	porcelain	white	1	FMM	Neimenggu zizhiqu bowuguan, Inner Mongolia	959	Cat. 33
Gr.1	Ab	porcelain	white	1		Capital museum, Beijing		Cat. 34
Gr.1	Ab	Pinkish earthenware	white	1	BZLG		middle	Cat. 35
Gr.1	Ab	Pinkish earthenware	Dark green	1	XHD		middle	Cat. 36
Gr.1	Ab	Pinkish earthenware	green	1		Jinlin provincial museum		Cat. 37
Gr.1	Ab	Pinkish earthenware	green	1	a tomb at Shazigou in Jinchanggouliang township, Aohan Banner, Inner Mongolia	Aohan Banner Museum, Inner Mongolia		Cat. 38
Gr.1	Ab	Pinkish earthenware	green	1	DEQG			Cat. 39

Group	Type	Body	Glaze	Amount	Unearthed From	Collected By	Date (AD)	Cat. No.
Gr.1	Ab	Pinkish earthenware	green	1		Tokyo national museum		Cat. 40
Gr.1	Ab	Pinkish earthenware	green	1		Philadelphia museum of art		Cat. 41
Gr.1	Ab	Pinkish earthenware	green	1		Indianapolis museum of art gift of Charles L. Freer		Cat. 42
Gr.1	Ab	Pinkish earthenware	green	1		Philadelphia museum of art		Cat. 43
Gr.1	Ab	Pinkish earthenware	green	1	a tomb at Lindong Zhuanchang, Balin Left Banner, Inner Mongolia	Liao shangjing museum, Inner Mongolia		Cat. 44
Gr.1	Ab	Pinkish earthenware	green	1		Guan Baocong collection		Cat. 45
Gr.1	Ab	Pinkish earthenware	green	1		Guan Baocong collection		Cat. 46
Gr.1	B	grey polishing pottery		1	a tomb at Yuliangbao, tongliao, Inner Mongolia		early	Cat. 47
Cat. 48	B	Black polishing pottery		1	Tomb at Shangshaoguo, louzidian township, kalaqin banner, Inner Mongolia	Chifeng municipal museum, Inner Mongolia	early	Cat. 48
Gr.1	B	grey polishing pottery		1	Tomb at Shangshaoguo, louzidian township, kalaqin banner, Inner Mongolia	Chifeng municipal museum, Inner Mongolia	early	Cat. 49

Group	Type	Body	Glaze	Amount	Unearthed From	Collected By	Date (AD)	Cat. No.
Gr.1	B	Porcelain	white	1		Liaoning provincial museum	early	Cat. 50
Gr.1	B	Pinkish earthenware	green	1		Liaoning provincial museum	early	Cat. 51
Gr.1	B	Pinkish earthenware	green	1	GDG	Chifeng municipal museum, Inner Mongolia	Middle	Cat. 52
Gr.1	B	Pinkish earthenware	brown	1	YMT7	Liaoning provincial museum	Middle	Cat. 53
Gr.1	B	Pinkish earthenware	brown	1	YMT7	Liaoning provincial museum	Middle	Cat. 54
Gr.1	B	Pinkish earthenware	yellow	1	a tomb at Tong County, Beijing	Capital museum, Beijing		Cat. 55
Gr.1	B	Pinkish earthenware	yellow	2	AXZ		Middle	Cat. 56
Gr.1	B	Pinkish earthenware	green	1	SQ1	Liaoning provincial museum	Middle	Cat. 57
Gr.1	B	Pinkish earthenware	green	1	SQ1	Liaoning provincial museum		Cat. 58

Group	Type	Body	Glaze	Amount	Unearthed From	Collected By	Date (AD)	Cat. No.
Gr.1	B	Pinkish earthenware	green	2	QCH	Liaoning provincial museum	1004	Cat. 59
Gr.1	B	Pinkish earthenware	green	2	QCH	Liaoning provincial museum	1004	Cat. 60
Gr.1	B	Pinkish earthenware	green	2	a tomb at Guangdegong township, Wengniute Banner, Inner Mongolia	Wengniute Banner Museum, Inner Mongolia		Cat. 61
Gr.1	B	Pinkish earthenware	green	1	ELC	Liaoning provincial museum		Cat. 62
Gr.1	B	Pinkish earthenware	green	1	ELC	Inner Mongolia Autonomous Region Museum		Cat. 63
Gr.1	B	Pinkish earthenware	green	1		Liaoning provincial museum		Cat. 64
Gr.1	B	Pinkish earthenware	green	1	YWG	Luanping museum, Hebei	middle	Cat. 65
Gr.1	B	Pinkish earthenware	green	1	YWG	Luanping museum, Hebei	middle	Cat. 66
Gr.1	B	Pinkish earthenware	green	1	YWG	Luanping museum, Hebei	middle	Cat. 67

Group	Type	Body	Glaze	Amount	Unearthed From	Collected By	Date (AD)	Cat. No.
Gr.1	B	Pinkish earthenware	green	2	HXM	Heibei provincial museum	1017	Cat. 68
Gr.1	B	Pinkish earthenware	green	1	GYG	Chaoyang museum, Liaoning	1020	Cat. 69
Gr.1	B	Pinkish earthenware	green	1	GYG	Chaoyang museum, Liaoning	1020	Cat. 70
Gr.1	B	Pinkish earthenware	yellow	2	a tomb at Zhangjiayingzi, Jianping, Liaoning	Liaoning provincial museum		Cat. 71
Gr.1	B	Pinkish earthenware	yellow	1	a tomb at Fuxingmenwai, Beijing			Cat. 72
Gr.1	B	Pinkish earthenware	green	1		Museum of Fine Arts, Boston		Cat. 73
Gr.1	B	Pinkish earthenware	green	1		Museum of Fine Arts: Hoyt Coll., Boston(50.1747-8)		Cat. 74
Gr.1	B	Pinkish earthenware	green	1		Liaoning provincial museum		Cat. 75
Gr.1	B	Pinkish earthenware	green	1		Philadelphia Museum of Art		Cat. 76
Cat. 77	B	Pinkish earthenware	green	1		Center of Asian Art and Culture, Avery Brundage Collection San Francisco, California		Cat. 77

Group	Type	Body	Glaze	Amount	Unearthed From	Collected By	Date (AD)	Cat. No.
Gr.1	B	Pinkish earthenware	green	1		Mr. Victor Hauge ,Falls Church, Virginia		Cat. 78
Gr.1	B	Pinkish earthenware	green	1		Tokyo university		Cat. 79
Gr.1	B	Pinkish earthenware	green	1		Private collection, Japan		Cat. 80
Gr.1	B	Pinkish earthenware	green	1		Liaoning provincial Museum		Cat. 81
Gr.1	B	porcelain	white	1		Liaoning provincial Museum		Cat. 82
Gr.1	B	Pinkish earthenware	green	1	a tomb at Haiwang village, Xuanwu district, Beijing			Cat. 83
Gr.1	B	Pinkish earthenware	green	1	a tomb Yingfenggou, Xindi Township, Aohan Banner, Inner Mongolia	Aohan Banner Museum		Cat. 84
Gr.1	B	Pinkish earthenware	green	1		Liaoning Provincial museum		Cat. 85
Gr.1	B	Pinkish earthenware	green	1		Liaoning Provincial museum		Cat. 86
Gr.1	B	Pinkish earthenware	white	1		Chifengshi wenwu gongzuozhan, Inner Mongolia		Cat. 87

Group	Type	Body	Glaze	Amount	Unearthed From	Collected By	Date (AD)	Cat. No.
Gr.1	B	Pinkish earthenware	green	1	GZX	Chaoyang museum, Liaoning	1026	Cat. 88
Gr.1	B	Pinkish earthenware	green	1	GZX	Chaoyang museum, Liaoning	1026	Cat. 89
Gr.1	B	Pinkish earthenware	green	2	BL1	Liaoning provincial museum	middle	Cat. 90
Gr.1	B	Pinkish earthenware	green	2	PJG1	Aohan Banner Museum, Inner Mongolia	middle	Cat. 91
Gr.1	B	Pinkish earthenware	green	2	YMT22	Aohan Banner Museum, Inner Mongolia	middle	Cat. 92
Gr.1	B	Pinkish earthenware	green	2	DPC	Zhangwuxian wenwu guanlisuo	middle	Cat. 93
Gr.1	B	Pinkish earthenware	green	1		Guan Baocong collection		Cat. 94

TABLE 28 LIST OF UNEARTHED OBJECTS AND OTHER COLLECTIONS: BAG-SHAPED PILGRIM FLASK WITH LOOP HANDLE

Group	Type	Body	Glaze	Amount	Unearthed From	Collected By	Date (AD)	Cat. No.
Gr.2	Aa	porcelain	brown	1	YLYZ	Research Institute of Cultural Relics and Archaeology of Inner Mongolia	941 or earlier	Cat. 95
Gr.2	Aa	porcelain	white	1	YLYZ	Research Institute of Cultural Relics and Archaeology of Inner Mongolia	941 or earlier	Cat. 96
Gr.2	Aa	porcelain	white	1	HLDT1	Liaoning Tieling quzhongyishuguan wenwuzu	early	Cat. 97
Gr.2	Aa	porcelain	white	1		Liaoning provincial museum	early	Cat. 98
Gr.2	Aa	porcelain	white	1		Guan Baocong collection	early	Cat. 99
Gr.2	Aa	porcelain	white	1	a tomb at Baoquan village, Shisan aobao township, Balin Left Banner, Inner Mongolia	Liao shangjing museum	early	Cat. 100
Gr.2	Aa	porcelain	white	1		Aohan Banner museum	early	Cat. 101
Gr.2	Aa	porcelain	white	1		Guan Baocong collection	early	Cat. 102
Gr.2	Aa	Pinkish earthenware	green	1	GDG	Chifeng municipal museum	middle	Cat. 103

Group	Type	Body	Glaze	Amount	Unearthed From	Collected By	Date (AD)	Cat. No.
Gr.2	Aa	Pinkish earthenware	green	1	BZLG	Inner Mongolia Autonomous Region museum	middle	Cat. 104
Gr.2	Aa	Pinkish earthenware	green	2	XSC4		late	Cat. 105
Gr.2	Aa	Pinkish earthenware	white	1	DSLT1		middle	Cat. 106
Gr.2	Aa	Pinkish earthenware	white	1	DSLT1		middle	Cat. 107
Gr.2	Aa	Pinkish earthenware	white	2	a tomb at Dongdashaan, Kelidai township, Aohan Banner, Inner Mongolia		middle	Cat. 108
Gr.2	Aa	Pinkish earthenware	white		YMT5		middle	Cat. 109
Gr.2	Aa	Pinkish earthenware	white	1		Guan Baocong collection	middle	Cat. 110
Gr.2	Aa	Pinkish earthenware	white	1		Guan Baocong collection	middle	Cat. 111
Gr.2	Aa	Pinkish earthenware	green	2	BL4		middle	Cat. 112
Gr.2	Aa	Pinkish earthenware	Hell green	1	SLG6	Research Institute of Cultural Relics and Archaeology of Inner Mongolia	middle	Cat. 113

Group	Type	Body	Glaze	Amount	Unearthed From	Collected By	Date (AD)	Cat. No.
Gr.2	Aa	Pinkish earthenware	Hell green	1	SLG6	Research Institute of Cultural Relics and Archaeology of Inner Mongolia	middle	Cat. 114
Gr.2	Aa	Pinkish earthenware	White and green	1		Meize Guan, Japan		Cat. 115
Gr.2	Aa	Pinkish earthenware	green	1		Tokyo national museum		Cat. 116
Gr.2	Aa	Pinkish earthenware	White and green	1		Tokyo national museum		Cat. 117
Gr.2	Aa	Pinkish earthenware	White and green	1	a tomb at Sanjiazi of Nangongyingzi, Kazuo county, Liaoning	Liaoning provincial museum		Cat. 118
Gr.2	Aa	Pinkish earthenware	White and green	1	a tomb at Gongyingzi, Kazuo county, Liaoning	Liaoning provincial museum		Cat. 119
Gr.2	Aa	Pinkish earthenware	White and green	1		Kyusei Atami Museum		Cat. 120
Gr.2	Aa	Pinkish earthenware	White and green	2	a tomb at Yousheng village, Baiyin aobao township, Balin Left Banner, Inner Mongolia	Liao shangjing museum		Cat. 121

Group	Type	Body	Glaze	Amount	Unearthed From	Collected By	Date (AD)	Cat. No.
Gr.2	Aa	Pinkish earthenware	green	1		Liaoning provincial museum		Cat. 122
Gr.2	Aa	Pinkish earthenware	green	2	a tomb at Santai of Pingfangzi commune in Kazuo county, Liaoning	Kazuo museum, Liaoning		Cat. 123
Gr.2	Aa	Pinkish earthenware	white	2	CGB11		middle	Cat. 124
Gr.2	Aa	Pinkish earthenware	White and green	1	DSL1		middle	Cat. 125
Gr.2	Aa	Pinkish earthenware	White and green	1	DSL1		middle	Cat. 126
Gr.2	Aa	Pinkish earthenware	White and green	1		Xianggen meishuguan, Japan		Cat. 127
Gr.2	Aa	Pinkish earthenware	White and brown	1		Guan Baocong collection		Cat. 128
Gr.2	Aa	Pinkish earthenware	White and green	1		Guan Baocong collection		Cat. 129
Gr.2	Aa	Pinkish earthenware	White and brown	1		Guan Baocong collection		Cat. 130

Group	Type	Body	Glaze	Amount	Unearthed From	Collected By	Date (AD)	Cat. No.
Gr.2	Aa	Pinkish earthenware	green	1		Guan baocong collection		Cat. 131
Gr.2	Aa	Pinkish earthenware	green	1		Liaoning provincial museum		Cat. 132
Gr.2	Aa	Pinkish earthenware	green	1		Guan baocong collection		Cat. 133
Gr.2	Aa	Pinkish earthenware	green	1		Guan baocong collection		Cat. 134
Gr.2	Aa	Pinkish earthenware	green	2	a tomb at Kangjiazhangzi, Jianping, Liaoning	Research Institute of cultural relics and archaeology of Liaoning province		Cat. 135
Gr.2	Aa	Pinkish earthenware	White and green	2	FJTGX	Chifeng municipal museum	late	Cat. 136
Gr.2	Aa	Pinkish earthenware	green	1	WLHD		Late	Cat. 137
Gr.2	Aa	Pinkish earthenware	green	1	WLHD		Late	Cat. 138
Gr.2	Aa	Pinkish earthenware	green	2	CDM		late	Cat. 139
Gr.2	Aa	Pinkish earthenware	White and green	2	a tomb at Shuangsheng village, Longchang county, Balin Left Banner, Inner Mongolia		late	Cat. 140

Group	Type	Body	Glaze	Amount	Unearthed From	Collected By	Date (AD)	Cat. No.
Gr.2	Aa	Pinkish earthenware	yellow	1		Guan Baocong collection	late	Cat. 141
Gr.2	Aa	Pinkish earthenware	White and green	1		Tenri Museum, Nara	late	Cat. 142
Gr.2	Aa	Pinkish earthenware	green	1	WJS1	Chifeng municipal museum	Late	Cat. 143
Gr.2	Ab	porcelain	white	1	HLB		early	Cat. 144
Gr.2	Ab	porcelain	white	1		Tokyo national museum	early	Cat. 145
Gr.2	Ab	porcelain	white	1	MTYZ1		early	Cat. 146
Gr.2	Ab	porcelain	Tee-dust green	1	a tomb at wusuyigen, Ganggen sumu, Balin Right Banner, Inner Mongolia	Balin Right banner museum		Cat. 147
Gr.2	Ab	porcelain	White glaze and black pigment	1	CYZ			Cat. 148
Gr.2	Ab	porcelain	white	1	a tomb at Xiaochengzi village, Chagannuo sumu, Balin Right Banner, Inner Mongolia	Balin Right banner museum		Cat. 149

Group	Type	Body	Glaze	Amount	Unearthed From	Collected By	Date (AD)	Cat. No.
Gr.2	Ab	porcelain	yellow	1				Cat. 150
Gr.2	Ab	porcelain	white	1				Cat. 151
Gr.2	Ab	porcelain	White glaze and black pigment	1				Cat. 152
Gr.2	Ab	porcelain	white	1	a tomb at Laopogou, Linjiadi township, Aohan Banner, Inner Mongolia	Aohan Banner museum	early	Cat. 153
Gr.2	Ab	porcelain	white	1	QHM1		middle	Cat. 154
Gr.2	Ab	porcelain	white	1		Tokyo national museum		Cat. 156
Gr.2	Ab	porcelain	white	1		Royal Ontario Museum, Toronto		Cat. 157
Gr.2	Ab	porcelain	white	1		Guan Baocong collection		Cat. 158
Gr.2	Ab	porcelain	white	1				Cat. 159
Gr.2	Ab	porcelain	white	1	DYZ3		middle	Cat. 160

Group	Type	Body	Glaze	Amount	Unearthed From	Collected By	Date (AD)	Cat. No.
Gr.2	Ab	Pinkish earthenware	white	1		Guan Baocong collection		Cat. 161
Gr.2	Ab	stoneware	white	1		Liaoning provincial museum		Cat. 162
Gr.2	Ab	stoneware	white	1		British Museum(1959 4-21)		Cat. 163
Gr.2	Ab	stoneware	white	1		Royal Ontario Museum, Toronto		Cat. 164
Gr.2	Ab	Pinkish earthenware	yellow	1	a tomb at Bayanshana, Chaganmulun sum, Balin Right banner, Inner Mongolia	Balin Right Banner museum		Cat. 165
Gr.2	Ab	Pinkish earthenware	green	1		Jinlin provincial museum		Cat. 166
Gr.2	Ab	Pinkish earthenware	white	1	a tomb at Chutoulang commune, Chifeng city, Inner Mongolia	Chifeng wenhuaguan wenwuzu		Cat. 167
Gr.2	Ab	Pinkish earthenware	yellow	1	JFYZ		late	Cat. 168
Gr.2	Ab	Pinkish earthenware	yellow	2	XBTB(MWG4)		1081	Cat. 169
Gr.2	Ab	Pinkish earthenware	white	1		Liaoning provincial museum		Cat. 170
Gr.2	Ab	Pinkish earthenware	green	1		Liaoning Tieling qunzhongyishuguan wenwuzu		Cat. 171

Group	Type	Body	Glaze	Amount	Unearthed From	Collected By	Date (AD)	Cat. No.
Gr.2	Ab	Pinkish earthenware	yellow	1		Liaoning provincial museum		Cat. 172
Gr.2	Ab	Pinkish earthenware	green	1		Liaoning provincial museum		Cat. 173
Gr.2	Ab	Pinkish earthenware	yellow	1	HPYZ1		late	Cat. 174
Gr.2	Ab	Pinkish earthenware	yellow	2	BL3		late	Cat. 175
Gr.2	Ab	Pinkish earthenware	yellow	1	PJG3		late	Cat. 176
Gr.2	Ab	Pinkish earthenware	green	2	QHM2		1057	Cat. 177
Gr.2	Ab	Pinkish earthenware	white		XDM		late	Cat. 178
Gr.2	Ab	Pinkish earthenware	yellow	2	LTL		late	Cat. 179
Gr.2	Ab	Pinkish earthenware	yellow			Jinlin provincial museum	late	Cat. 180
Gr.2	Ab	Pinkish earthenware	white			Liaoning tieling qunzhongyishuguan wenwuzu	late	Cat. 181
Gr.2	Ab	Pinkish earthenware	yellow	2	WJS2	Chifeng municipal museum	late	Cat. 182
Gr.2	Ab	Pinkish earthenware	brown	2	a tomb at Erbadi, Yanchang township, Balin Right banner	Balin Right banner museum	late	Cat. 183

Group	Type	Body	Glaze	Amount	Unearthed From	Collected By	Date (AD)	Cat. No.
Gr.2	Ab	Pinkish earthenware	Green	2	a tomb at Shuangsheng village, Longchang township, Balin Left banner	Liao shangjin museum, Inner Mongolia	late	Cat. 184
Gr.2	Ab	stoneware	white	1		Zhengmu museum, Japan		Cat. 185
Gr.2	Ab	Pinkish earthenware	yellow	1	BTYZ		late	Cat. 186
Gr.2	Ab	Pinkish earthenware	green	1		Mr. Victor Hauge Falls Church, Virginia		Cat. 187
Gr.2	Ab	Pinkish earthenware	yellow	1		Royal Ontario Museum, Toronto		Cat. 188
Gr.2	Ab	Pinkish earthenware	green	1		Japanese private collection		Cat. 189
Gr.2	Ab	Pinkish earthenware	yellow	1		Japanese private collection		Cat. 190
Gr.2	Ab	Pinkish earthenware	yellow	1		Japanese private collection		Cat. 191
Gr.2	Ab	Pinkish earthenware	yellow	1	a tomb at Pingfangzi, Kaozuo county, Chaoyang city, Liaoning	Kazuo museum, Liaoning	late	Cat. 192
Gr.2	Ab	Pinkish earthenware	yellow	1		Gugong bowuyuan, Beijing	late	Cat. 193
Gr.2	Ab	Pinkish earthenware	green	1		Guan Baocong collection	late	Cat. 194

Group	Type	Body	Glaze	Amount	Unearthed From	Collected By	Date (AD)	Cat. No.
Gr.2	Ab	Pinkish earthenware	green	1			late	Cat. 195
Gr.2	Ab	Pinkish earthenware	green	1			late	Cat. 196
Gr.2	Ab	Pinkish earthenware	yellow	1		Liaoning provincial museum	late	Cat. 197
Gr.2	Ab	Pinkish earthenware	yellow	1		Japanese private collection		Cat. 198
Gr.2	Ab	Pinkish earthenware	green	1		Japanese private collection		Cat. 199
Gr.2	Ab	Pinkish earthenware	green	1		Japanese private collection		Cat. 200
Gr.2	Ab	Pinkish earthenware	green	1		Liaoning provincial museum	late	Cat. 201
Gr.2	Ab	Pinkish earthenware	green	1		Guan Baocong collection	late	Cat. 202
Gr.2	Ab	Pinkish earthenware	yellow	1		Guan Baocong collection	late	Cat. 203
Gr.2	Ab	Pinkish earthenware	yellow	1		Guan Baocong collection	late	Cat. 204
Gr.2	Ab	Pinkish earthenware	green	1		Brooklyn Museum, New York	late	Cat. 205
Gr.2	Ab	stoneware	white	1		Aohan Banner museum, Inner Mongolia	late	Cat. 206

Group	Type	Body	Glaze	Amount	Unearthed From	Collected By	Date (AD)	Cat. No.
Gr.2	Ab	Pinkish earthenware	yellow	1	a tomb at Shanzuizi village, Sanzuodian township, Ningcheng county, Inner Mongolia	Research institute of cultural relics and archaeology of Inner Mongolia	late	Cat. 207
Gr.2	Ab	Pinkish earthenware	green	1		Liaoshangjing museum, Inner Mongolia	late	Cat. 208
Gr.2	Ab	Pinkish earthenware	green	1		Royal Ontario Museum, Toronto		Cat. 209
Gr.2	Ab	Pinkish earthenware	yellow	1		Philadelphia Museum of Art		Cat. 210
Gr.2	Ab	Pinkish earthenware	yellow	1		Japanese private collection		Cat. 211
Gr.2	Ab	stoneware	white	1		Guan Baocong collection	late	Cat. 212
Gr.2	Ab	Pinkish earthenware	yellow	1		Guan Baocong collection	late	Cat. 213
Gr.2	Ab	Pinkish earthenware	yellow	1		Guan Baocong collection	late	Cat. 214
Gr.2	Ab	Pinkish earthenware	green	1		Guan Baocong collection	late	Cat. 215
Gr.2	Ab	Pinkish earthenware	green	1		Guan Baocong collection	late	Cat. 216
Gr.2	Ab	porcelain	white	1		Guan Baocong collection	late	Cat. 217

Group	Type	Body	Glaze	Amount	Unearthed From	Collected By	Date (AD)	Cat. No.
Gr.2	Ab	Pinkish earthenware	yellow	1		Guangdong provincial museum	late	Cat. 218
Gr.2	B	porcelain	green	1		Center of Asian Art and Culture, Avery Brundage Collection, San Francisco	early	Cat. 219
Gr.2	B	porcelain	White glaze with brown pigment	1		Victoria and Albert Museum, London	8 th century	Cat. 220
Gr.2	B	Pinkish earthenware	yellow	1	JSF	Capital museum, Beijing	late	Cat. 221
Gr.2	B	Pinkish earthenware	Green	1			late	Cat. 222
Gr.2	B	stoneware	white	1		Liaoning provincial museum	late	Cat. 223
Gr.2	B	porcelain	white	1	a tomb at Xi'an, Shaanxi		8 th century	Cat. 224
Gr.2	B	porcelain	white	1			8 th century	Cat. 225
Gr.2	B	porcelain	white	1		Guan Baocong collection	8 th century	Cat. 226
Gr.2	B	porcelain	white	1	a tomb at Xi'an, Shaanxi		8 th century	Cat. 227

Group	Type	Body	Glaze	Amount	Unearthed From	Collected By	Date (AD)	Cat. No.
Gr.2	B	Porcelain	celadon	1	a tomb at Nantong city, Jiangsu province		8 th century	Cat. 228
Gr.2	B	Pinkish earthenware	Three-col or glaze	1		Museum of Fine Arts: Hoyt Coll., Boston.	8 th century	Cat. 229
Gr.2	B	Pinkish earthenware	Three-col or glaze	1		Tokyo national museum	8 th century	Cat. 230

TABLE 29 LIST OF UNEARTHED OBJECTS AND OTHER COLLECTIONS: LUGGED PILGRIM FLASK

Type	Body	Glaze	Amount	Unearthed From	Collected By	Date (AD)	Cat. No.
	Grey pottery		2	HSN		early	Cat. 231
	Grey pottery		2	ZKC4		early	Cat. 232
	stoneware	brown	1		Guan Baocong collection	early	Cat. 233
	Pinkishearthe nware	brown	1	a tomb at Ningcheng, Inner Mongolia	Liaoning provincial museum	early	Cat. 234
	Pinkishearthe nware	brown	1	DQTL3		early	Cat. 235
	Pinkishearthe nware	green	1		Guan Baocong collection	early	Cat. 236
	Pinkishearthe nware	green	1	GDG	Chifeng municipal museum, Inner Mongolia		Cat. 237
	stoneware	green	1	a tomb at Fanshan in Yuhang county, Zhejiang province		1-3th century	Cat. 238
	porcelain	yellow	1	the tomb of Fancui at Anyang city, Henan province		575	Cat. 239

TABLE 30 LIST OF UNEARTHED OBJECTS AND OTHER COLLECTIONS: LUGGED VASE

Type	Body	Glaze	Amount	Unearthed From	Collected By	Date (AD)	Cat. No.
A	porcelain	white	1	DQTL3		early	Cat. 240
A	porcelain	white		YLYZ		942	Cat. 241

Type	Body	Glaze	Amount	Unearthed From	Collected By	Date (AD)	Cat. No.
A	Pinkish earthen ware	White glazed with green splashes	1		Liaoning provincial museum	Probably 11 th century	Cat. 242
B	porcelain	white	1	ZKC4		early	Cat. 243
B	Buff stoneware	green	1	MTYZ2		early	Cat. 244
BI	porcelain	white	1	a tomb at Baoquan village, Balin Left banner, Inner Mongolia.	Liaoshangjing museum, Inner Mongolia	early	Cat. 245
BI	Buff stoneware	white	1	a tomb at Bolochi, Chaoyang, Liaoning		early	Cat. 246
B	Buff stoneware	yellow	1	a tomb at Tuchengzi, Helinge'er county, Huhhot, Inner Mongolia	Inner Mongolia Autonomous Region Museum		Cat. 247
B	Buff stoneware	yellow	1	a tomb at Shantiaomao, Qinshuihe, Inner Mongolia			Cat. 248
B	Buff stoneware	Green	1	YLYZ	Research institute of cultural relics and archaeology of Inner Mongolia	942	Cat. 249
B	Buff stoneware	Green	1		The Detroit Institute of Arts, gift of Edgar Worch		Cat. 250
B	Buff stoneware	Green	1		Mengdiexuan collection		Cat. 251
B	Buff stoneware	Green	1	DST3			Cat. 252

TABLE 31 LIST OF UNEARTHED OBJECTS AND OTHER COLLECTIONS: BOWL-MOUTH BOTTLE

Type	Body	Glaze	Amount	Unearthed From	Collected By	Date (AD)	Cat. No.
------	------	-------	--------	----------------	--------------	-----------	----------

Type	Body	Glaze	Amount	Unearthed From	Collected By	Date (AD)	Cat. No.
A	Pottery		1	DHG1		early	Cat. 254
A	Pottery		1	HSN			Cat. 255
A	Pottery		1	NZLYZ1		early	Cat. 256
A	Pottery		1	A tomb at Wurigentala, Zhalute Banner, Inner Mongolia		early	Cat. 257
A	Pottery		1	A tomb at Wusitu, Tongliao, Inner Mongolia		early	Cat. 258
A	Stoneware	brown	1	NZLYZ1		early	Cat. 259
A	Pottery		1	A tomb at Sandaohao, Liaoyang city, Liaoning Province		early	Cat. 260
A	Pottery		1	EBD1			Cat. 261
A	Pottery		1	A tomb at Rezhong commune of keshiketeng Banner, Inner Mongolia	Chifeng municipal museum		Cat. 262
A	Pottery		1	YLYZ	Research institute of cultural relics and archaeology of Inner Mongolia	942	Cat. 263
A	Pottery		1	SZG1		early	Cat. 264
B	Stoneware	yellow	1	HSN		early	Cat. 265

Type	Body	Glaze	Amount	Unearthed From	Collected By	Date (AD)	Cat. No.
B	Pottery		1	Tomb at Liutiaogou, Beipiao, Liaoning			Cat. 266
B	Stoneware	brown	1	YLYZ	Research institute of relics and archaeology of Inner Mongolia	942	Cat. 267
C	Stoneware	yellow	1	HSN		early	Cat. 268

TABLE 32 LIST OF UNEARTHED OBJECTS AND OTHER COLLECTIONS: CARINATE-SHOULDER BOTTLE

Type	Body	Glaze	Amount	Unearthed From	Collected By	Date (AD)	Cat. No.
A	Gilt silver		1	MTYZ1			Cat. 269
A	Gold		1	Kebinei			Cat. 270
A	Gold		1		Privat collection		Cat. 271
A	Gilt silver		1		Mengdiexuan collection, HongKong		Cat. 272
A	Silver		1	Tomb at Lijiayingzi, Kangjiayingzi Township, Aohan Banner, Inner Mongolia.	Aohan Banner Museum, Inner Mongolia		Cat. 273
A	Pinkish earthenware	green	1	HLB1		early	Cat. 274
A	Pinkish earthenware	green	1	Chifeng city, Inner Mongolia	Chifeng municipal antique shop	early	Cat. 275
A	Pinkish earthenware	green	1	Tomb at Chaoyanggou, Zhangwu city, Liaoning province	Zhangwu municipal relics office.	early	Cat. 276
A	Buff stoneware	white	1	NZLYZ1		early	Cat. 277

Type	Body	Glaze	Amount	Unearthed From	Collected By	Date (AD)	Cat. No.
A	Buff stoneware	white	1	QJZ	Fuxinshi wenhuaju wenwuzu, Liaoning province	early	Cat. 278
A	Pinkish earthenware	green	1		Privat collection		Cat. 279
A	Pinkish earthenware	green	1	a tomb at Pingquan County, Hebei Province.	Pinquan prefectural Museum, Hebei Province.	Middle	Cat. 280
A	Pinkish earthenware	green	1	GDG	Chifeng municipal museum	Middle	Cat. 281
A	Porcelain	white	1	HYM		997	Cat. 282
B	Polished black pottery		1		Aohan museum , Inner Mongolia	early	Cat. 284
B	Pinkish earthenware	black	1	ZJY1		early	Cat. 285
B	Porcelain	white	1	KPYZ1		early	Cat. 286
B	Stoneware	white	1		Aohan Banner museum		Cat. 287
B	Pinkish earthenware	yellow	1		Privat collection	late	Cat. 288
B	Buff stoneware	white	1		Guan Baocong collection	late	Cat. 289
B	Pinkish earthenware	green	1		Liaoshangjing museum, Inner Mongolia		Cat. 290
B	Pinkish earthenware	Yellow and green	1		Guan Baocong collection	late	Cat. 291

TABLE 33 LIST OF UNEARTHED OBJECTS AND OTHER COLLECTIONS: LONG-NECK VASE

Type	Body	Glaze	Amount	Unearthed From	Collected By	Date (AD)	Cat. No.
A	porcelain	white	1	ZLK	Liaoning provincial museum	early	Cat. 293
A	porcelain	white	2		FMM	959	Cat. 296
A	porcelain	white	1		Seattle Art Museum, Eugene Fuller Memorial Collection	early	Cat. 294
A	porcelain	white	1		Nelson Gallery-Atkins Museum, Kansas City	early	Cat. 295
A	porcelain	white			The Metropolitan Museum of Art, New York ,Gift of Mrs. Samuel T. Peters	early	Cat. 297
A	Pinkish earthenware	green	1	AXZ			Cat. 298
A	Yellowish stoneware	white	1		Guan Baocong collection		Cat. 299
A	Pinkish earthenware	Green and yellow	1	EBD2		early	Cat. 300
A	Yellowish stoneware	white	2	QHM1		1044	Cat. 306
A	Yellowish stoneware	white	1	KL3		Middle	Cat. 307
A	Yellowish stoneware	white	1	YMT7	Liaoning provincial museum	977	Cat. 301

Type	Body	Glaze	Amount	Unearthed From	Collected By	Date (AD)	Cat. No.
A	Yellowish stoneware	white		Tomb at Majiagou, Linyuan county, Liaoning			Cat. 305
A	Yellowish stoneware	white	1	a tomb at Yimatu, Beizifu township, Aohan Banner, Inner Mongolia	Aohan Banner Museum, Inner Mongolia		Cat. 308
A	Yellowish stoneware	white	1		British Museum, London (1986 10-12 186)		Cat. 309
A	Yellowish stoneware	white	1		Liaoning provincial museum		Cat. 310
A	Yellowish stoneware	white	1				14
A	Yellowish stoneware	white	1		Guan Baocong collection		Cat. 311
A	Yellowish stoneware	white	1		The Metropolitan Museum of Art, New York		Cat. 302
A	Yellowish stoneware	white	1		Idemitsu Museum of Art, Tokyo		Cat. 304
A	Pinkish earthenware	white	1		Japanese collection		Cat. 312
A	Pinkish earthenware	white	1		Tokyo National museum		Cat. 313
A	Pinkish earthenware	white	1	a tomb at Buhetehada, Bayanerdeng Sumu, Balin Right Banner, Inner Mongolia	Baling Right Banner Museum, Inner Mongolia		Cat. 314

Type	Body	Glaze	Amount	Unearthed From	Collected By	Date (AD)	Cat. No.
A	Pinkish earthenware	green	1		The palace museum, Beijing	late	Cat. 315
A	Pinkish earthenware	green	1		Guan Baocong collection	late	Cat. 316
A	Pinkish earthenware	green	1		Guan Baocong collection	late	Cat. 317
A	Pinkish earthenware	green	1		The Lowe Art Museum University of Miami	late	Cat. 318
A	Pinkish earthenware	green	1		Guan Baocong collection	late	Cat. 319
A	Pinkish earthenware	green	1	a tomb at Dalaming'anla, Meilihe commune, Chifeng city, Inner Mongolia	Chifeng municipal museum, Inner Mongolia	late	Cat. 320
Pro-type	pottery			DHG1		early	Cat. 321
Pro-type	pottery			NZLYZ1		early	Cat. 322
B	Pinkish earthenware	green	1	SZG1		early	Cat. 323
B	Pinkish earthenware	brown	1	HLB1		early	Cat. 324
B	Pinkish earthenware	brown	1		Guan Baocong collection	early	Cat. 325
B	Pinkish earthenware	green	1	a tomb at Ningcheng, Inner Mongolia	Liaoning provincial museum		Cat. 326

Type	Body	Glaze	Amount	Unearthed From	Collected By	Date (AD)	Cat. No.
B	Pinkish earthenware	brown	2	YMT7	Liaoning provincial museum	977	Cat. 327
B	Pinkish earthenware	green	2	CGGZ	Inner Mongolia cultural relics and archaeology institute	1018	Cat. 328
B	Pinkish earthenware	green	2	KL3			Cat. 329
B	Pinkish earthenware	green	2	a tomb at Jinchanggouliang township, Aohan Banner, Inner Mongolia	Aohan Banner Museum, Inner Mongolia		Cat. 330
B	Pinkish earthenware	white	2	QHM4	Liaoning provincial museum	1032-1064	Cat. 331
B	Pinkish earthenware	green	1	a tomb at Baoquan village, Shisan'aobao township, Balin Left Banner, Inner mongolia	Liaoshangjing museum, Inner Monglia		13
B	Pinkish earthenware	green		BTYZ	Liaoning provincial museum	late	Cat. 338
B	Pinkish earthenware	yellow		BL3		late	Cat. 339
B	Pinkish earthenware	green		YWG		late	Cat. 340
B	Pinkish earthenware	green	1	a tomb at Qiaotou Township, Wengniute Banner, Inner Mongolia	Wengniute Banner Museum, Inner Mongolia	late	Cat. 333

Type	Body	Glaze	Amount	Unearthed From	Collected By	Date (AD)	Cat. No.
B	Pinkish earthenware	yellow	2	a tomb at Erguanyingzi, Beizifu Township, Aohan Banner, Inner Mongolia	Aohan Banner Museum, Inner Mongolia	late	Cat. 335
B	Pinkish earthenware	white	1		Japanese collection		Cat. 334
B	Pinkish earthenware	yellow	1		Guan Baocong collection		Cat. 336
B	Pinkish earthenware	yellow	1		Japanese collection		Cat. 341
B	Pinkish earthenware	yellow	1		Liaoning provincial museum		Cat. 342
B	Pinkish earthenware	yellow	1		Japanese collection		Cat. 343
B	Pinkish earthenware	yellow	1		Guan Baocong collection		Cat. 337
B	Pinkish earthenware	yellow	1		Guan Baocong collection		Cat. 345
B	Pinkish earthenware	green	1		Center of Asian Art and Culture, Avery Brundage Collection, San Francisco, California		Cat. 346
B	Pinkish earthenware	white	1		Guan Baocong collection		Cat. 348

Type	Body	Glaze	Amount	Unearthed From	Collected By	Date (AD)	Cat. No.
B	Pinkish earthenware	green	1		Center of Asian Art and Culture, Avery Brundage Collection, San Francisco, California	late	Cat. 347
B	Pinkish earthenware	yellow	1		Liaoning provincial museum	late	Cat. 344
B	Pinkish earthenware	white	1	a tomb at Xishan, Yemaotai, Faku, Liaoning province	Liaoning Tieling qunzhongyishuguan wenwuzu	late	Cat. 332

TABLE 34 LIST OF UNEARTHED OBJECTS AND OTHER COLLECTIONS: PHOENIX-HEAD VASE

Type	Body	Glaze	Amount	Unearthed From	Collected By	Date (AD)	Cat. No.
A	Porcelain	white	1		Japanese collection	early	Cat. 349
A	porcelain	white	1		The library of Gaotang county, Shandong province	early	Cat. 350
A	Pinkish earthenware	Green	2	QCH	Liaoning provincial museum	middle	Cat. 351
A	Pinkish earthenware	Green	2	SQ1	Liaoning provincial museum	middle	Cat. 352
A	Pinkish earthenware	green	2	QHM2	Liaoning provincial museum	1057	Cat. 353
A	Pinkish earthenware	green	1	a tomb at Tuquan county, Xing'an League, Inner Mongolia	Inner Mongolia autonomous region museum		Cat. 354

Type	Body	Glaze	Amount	Unearthed From	Collected By	Date (AD)	Cat. No.
A	Pinkish earthenware	yellow	1	The wall city of Qingzhou, Suoboriga Township, Balin Right Banner	Balin Right Banner Museum, Inner Mongolia		Cat. 355
A	Pinkish earthenware	green	1		Tokyo national museum		Cat. 356
A	Pinkish earthenware	yellow	1		Liaoning provincial museum		Cat. 357
A	Pinkish earthenware	yellow	1		Liaoning provincial museum		Cat. 358
A	Pinkish earthenware	green	1	CKTDS4	Chifeng municipal museum, Inner Mongolia	late	Cat. 359
A	Pinkish earthenware	green	2	a tomb at Dongdashaan, Kelidai Township, Aohan Banner, Inner Mongolia	Aohan Banner Museum, Inner Mongolia	late	Cat. 360
A	Pinkish earthenware	yellow	2	a tomb at Jiefangtun, Sijizi Township, Aohan Banner, Inner Mongolia	Aohan Banner Museum, Inner Mongolia	late	Cat. 361
A	Pinkish earthenware	green		XXZ		1089	Cat. 362
A	Pinkish earthenware	yellow	2	XLZZ2		late	Cat. 365
A	Pinkish earthenware	yellow	2	FZZ		late	Cat. 364
A	Pinkish earthenware	yellow	2	XPJG		late	Cat. 363

Type	Body	Glaze	Amount	Unearthed From	Collected By	Date (AD)	Cat. No.
A	Pinkish earthenware	green	1		Japanese collection	late	Cat. 366
A	Pinkish earthenware	green	1		Liaoning provincial museum	late	Cat. 367
A	Pinkish earthenware	green	1		Guan Baocong collection	late	Cat. 368
B	Pinkish earthenware	white	1		The Museum Yamato Bunkakan,Nara	middle	Cat. 369
B	Pinkish earthenware	white	1		Royal Ontario Museum, Toronto		Cat. 370
	porcelain	white	1		Idemitsu Bijutsukan, Tokyo	Tang	Cat. 373
	porcelain	white	1		British Museum, London	Tang	Cat. 374
	porcelain	white	1		British Museum, London	Tang	Cat. 375
				a tomb at Zhaoduba, Chaoyang, Liaoning		late	Cat. 376
	silver				Inner Mongolia autonomous region museum	Tang	Cat. 377

TABLE 35 LIST OF UNEARTHED OBJECTS AND OTHER COLLECTIONS: SPOUTED EWER (PITCHER)

Type	Body	Glaze	Amount	Unearthed From	Collected By	Date (AD)	Cat. No.
Aa	Buff stoneware	white		HLB1		early	Cat. 378

Type	Body	Glaze	Amount	Unearthed From	Collected By	Date (AD)	Cat. No.
Aa	Buff stoneware	green	2	DQTL3		early	Cat. 379
Aa	Buff stoneware	green	1	a tomb at Zhengning county, Gansu province	Zhenning prefectural Museum, Gansu province	early	Cat. 380
Aa	Buff stoneware	green	1		Mr. and Mrs Myron S. Falk, Jr. New York	early	Cat. 381
Aa	Pinkish earthenware	yellow	1		Liaoning provincial museum	early	Cat. 382
Aa	Buff stoneware	yellow	1		Formerly Frederick M. Mayer Co.	early	Cat. 383
Aa	Buff stoneware	yellow	1		Indianapolis Museum of Art, Gift of Warden McKee Wilson	early	Cat. 384
Aa	Pinkish earthenware	White glaze with green pigment	1	BYD		early	Cat. 385

Type	Body	Glaze	Amount	Unearthed From	Collected By	Date (AD)	Cat. No.
Aa	Buff stoneware	green	1		Tokyo national museum	early	Cat. 386
Aa	Porcelainous stoneware	white	1	FMM		959	Cat. 387
Aa	Porcelainous stoneware	green	1		Aohan Banner Museum, Inner Mongolia	early	Cat. 389
Aa	Porcelainous stoneware	white	1		Aohan Banner Museum, Inner Mongolia	early	Cat. 391
Aa	Porcelainous stoneware	white	1		Guan Baocong collection	early	Cat. 392
Aa	Porcelainous stoneware	white	1	ZLK	Liaoning provincial museum	early	Cat. 388
Aa	Buff stoneware	white	1	BL4		middle	Cat. 393
Aa	Buff stoneware	white	1		Guan Baocong collection	middle	Cat. 394

Type	Body	Glaze	Amount	Unearthed From	Collected By	Date (AD)	Cat. No.
Aa	Buff stoneware	white	1	a tomb at Laopogou, Linjiadi Township. Aohan Banner, Inner Mongolia	Aohan Banner Museum, Inner Mongolia	middle	Cat. 395
Aa	porcelain	white		SJG1		1002	Cat. 396
Aa	Pinkish erathenware	green		YMT22		middle	Cat. 397
Aa	porcelain	white	1	BL1	Liaoning Provincial Museum	middle	Cat. 398
Aa	Pinkish erathenware	green	1	QCH	Liaoning Provincial Museum	middle	Cat. 399
Aa	porcelain	white	1	SQ1	Liaoning Provincial Museum	middle	Cat. 400
Aa	porcelain	white	1	A tomb at Shuiquan, Beipiao county, Liaoning province	Liaoning Provincial museum	middle	Cat. 401
Aa	porcelain	white	1		Liaoning tieling qunzhongyishuguan wenwuzu	middle	Cat. 402

Type	Body	Glaze	Amount	Unearthed From	Collected By	Date (AD)	Cat. No.
Aa	Buff stoneware	white	1	Tomb at Chaoyanggou, Zhangwu, Liaoning province	Relics office of Zhangwu city, Liaoning province	middle	Cat. 403
Aa	Pinkish earthenware	green	1		Aohan Banner Museum	middle	Cat. 404
Aa	Porcelain	white	1	SSG4		middle	Cat. 405
Aa	Porcelain	white	1	A tomb at Baixintun, Keyouqian Banner, Inner Mongolia	Inner Mongolia Autonomous Region Museum	middle	Cat. 406
Aa	Porcelain	white	1	a tomb at Yimatu, Beizifu township, Aohan Banner, Inner Mongolia	Aohan Banner Museum	middle	Cat. 407
Aa	stoneware	white	1		The palace museum, Peking	middle	Cat. 408
Aa	Pinkish earthenware	yellow	1	GZX		1027	Cat. 409
Aa	Pinkish earthenware	yellow	1	A tomb at Wuqintulu village, Zhangjiayingzi Township, Jianping county, Liaoning Province	Liaoning Provincial Museum	middle	Cat. 410

Type	Body	Glaze	Amount	Unearthed From	Collected By	Date (AD)	Cat. No.
Aa	Pinkish earthenware	yellow	1		Tokyo National museum	middle	Cat. 411
Aa	Pinkish earthenware	white	1		Chinese private collection	middle	Cat. 412
Aa	Pinkish earthenware	white	1		Chinese private collection	middle	Cat. 413
Aa	Pinkish earthenware	green	1		Guan Baocong collection	middle	Cat. 414
Aa	Pinkish earthenware	Yellow	1	JFYZ	Chifeng Municipal museum, Inner Mongolia	late	Cat. 415
Aa	porcelain	white	1	YMT2		late	Cat. 416
Aa	porcelain	white	1	A tomb at Xishan of Yemaotai in Faku county, Liaoning province	Liaoning Provincial Museum	Late	Cat. 417
Aa	porcelain	white	1	Tomb at Tangjiazhangzi, Jianping city, Liaoning province	Research institute of Relics and Archaeology of Liaoning province	late	Cat. 418

Type	Body	Glaze	Amount	Unearthed From	Collected By	Date (AD)	Cat. No.
Aa	porcelain	white	1	MTYZ1		late	Cat. 419
Aa	porcelain	white	1		Liaoning Provincial Museum	late	Cat. 420
Aa	porcelain	white	1		Liaoning provincial museum	late	Cat. 421
Aa	porcelain	white	1	A tomb at Yaojiagou, Jinchanggouliang township, Aohan Banner, Inner Mongolia	Aohan Banner Museum	late	Cat. 422
Aa	Pinkish erathenware	Yellow	1		Chinese privat collection	late	Cat. 423
Aa	Pinkish erathenware	green		XHD		middle	Cat. 424
Aa	Pinkish erathenware	Three-col or	1		Liaoning Provincial Museum	late	Cat. 425
Aa	Pinkish erathenware	Three-col or	1		Chinese privat collection	late	Cat. 426

Type	Body	Glaze	Amount	Unearthed From	Collected By	Date (AD)	Cat. No.
Aa	Pinkish erathenware	yellow	1		Chinese privat collection	late	Cat. 427
Aa	Pinkish erathenware	Three- color	1		Guan Baocong collection	late	Cat. 428
Aa	Pinkish erathenware	Three- color	1	QJG1	Chifeng municipal museum, Inner Mongolia	late	Cat. 429
Ab	porcelain	white	1	GYG		1020	Cat. 430
Ab	Buff stoneware	green	1		Tokyo national museum	late	Cat. 431
Ab	porcelain	white	1	QHM2		1057	Cat. 432
Ab	porcelain	white	1	QHM2		1057	Cat. 433
Ab	porcelain	white	1		Liaoning Provincial Museum	late	Cat. 434

Type	Body	Glaze	Amount	Unearthed From	Collected By	Date (AD)	Cat. No.
	porcelain	white	1	a tomb at Luanping, Hebei			Cat. 435
B	porcelain	white	2	YMT7	Liaoning provincial museum	977	Cat. 436
B	porcelain	white		YMT7	Liaoning provincial museum	977	Cat. 437
B	porcelain	white	2	YMT7	Liaoning provincial museum	977	Cat. 438
B	porcelain	white	1	SQ1	Liaoning provincial museum	middle	Cat. 439
B	Pinkish earthenware	green	1		Liaoning provincial museum	middle	Cat. 440
B	Pinkish earthenware	white	1	XTTG3		middle	Cat. 441
B	porcelain	white	1		Liaoning Provincial Museum.	middle	Cat. 442

Type	Body	Glaze	Amount	Unearthed From	Collected By	Date (AD)	Cat. No.
B	Buff stoneware	white	1		Royal Ontario Museum, Toronto		Cat. 443
B	Buff stoneware	white	1		Guan Baocong collection		Cat. 444
B	porcelain	white	1		The palace museum, Peking		Cat. 445
B	porcelain	white	1	a tomb at Tongliao, Jilin province			Cat. 446
B	Buff stoneware	white	1	XDM	Chifeng wenhuaguan wenwuzu	Late	Cat. 447
B	Buff stoneware	white	1	a tomb at Yezhushan, Mutouyingzi Township, Aohan Banner, Inner Mongolia	Aohan Banner Museum, Inner Mongolia	Late	Cat. 448
B	Buff stoneware	white	1		Lianing provincial museum	Late	Cat. 449
B	Buff stoneware	white	1		Chinese privat collection	Late	Cat. 450

Type	Body	Glaze	Amount	Unearthed From	Collected By	Date (AD)	Cat. No.
B	Buff stoneware	white	1		Chinese privat collection	Late	Cat. 451
Ca	porcelain	white	1	HLDT2		early	Cat. 452
Ca	Buff stoneware	green	1		Seattle At Museum Eugene Fuller Memorial Collection	early	Cat. 453
Ca	Buff stoneware	brown	1	PJG2	Aohan Banner Museum	Late	Cat. 454
Ca	porcelain	white	1	KL1		1080	Cat. 455
Ca	Buff stoneware	brown	1	a tomb at Helihaolai, Naiman Banner, Inner Mongolia	Jilin Provincial Museum	Late	Cat. 456
Ca	Buff stoneware	white	1	a tomb at Fengtai, Beijing	Capital Museum, Beijing	Late	Cat. 457
Ca	Pinkish earthenware	white	1	BL3		late	Cat. 458

Type	Body	Glaze	Amount	Unearthed From	Collected By	Date (AD)	Cat. No.
Ca	Pinkish earthenware	yellow	1	A tomb at Shanzuizi commune of Kazuo county, Liaoning province	Liaoning Provincial Museum	late	Cat. 459
Ca	Pinkish earthenware	yellow	1		Liaoning Provincial Museum	late	Cat. 460
Ca	Pinkish earthenware	yellow	1		Liaoning Provincial Museum	late	Cat. 461
Ca	Pinkish earthenware	yellow	1		Tokyo National Museum	late	Cat. 462
Ca	Pinkish earthenware	yellow	1		? Art Museum, Japan	late	Cat. 463
Ca	Pinkish earthenware	yellow	1		Guan Baocong collection	late	Cat. 464
Ca	Pinkish earthenware	yellow	1	A tomb at Kunduling, Shuiquan Township, Kulun Banner, Inner Mongolia	Tongliao Museum, Inner Mongolia	late	Cat. 465
Ca	Pinkish earthenware	yellow	1	a tomb at Xiaokengzi, Niugutu Township, Aohan Banner, Inner Mongolia	Aohan Banner Museum, Inner Mongolia	late	Cat. 466

Type	Body	Glaze	Amount	Unearthed From	Collected By	Date (AD)	Cat. No.
Ca	Pinkish earthenware	yellow	1		Aohan Banner Museum, Inner Mongolia	Late	Cat. 467
Ca	Pinkish earthenware	yellow	1		Chifeng municipal museum, Inner Mongolia	late	Cat. 468
Ca	Buff stoneware	white	1		Guan Baocong Collection	late	Cat. 469
Ca	porcelain	white	1	a tomb at Yangchang Township, Baling Right Banner, Inner Mongolia	Balin Right Banner Museum, Inner Mongolia	late	Cat. 470
Ca	Pinkish earthenware	green	1		Chinese privat collection	late	Cat. 471
Ca	Stoneware	white	1	a tomb at Haoertu Township, Banlin Left Banner, Inner Mongolia	Liaoshangjing Museum, Inner Mongolia	late	Cat. 472
Ca	Stoneware	white	1		Liaoning provincial museum	late	Cat. 473
Ca	Stoneware	white	1		Guan Baocong collection	late	Cat. 474

Type	Body	Glaze	Amount	Unearthed From	Collected By	Date (AD)	Cat. No.
Ca	Stoneware	brown	1		Guan Baocong collection	late	Cat. 475
Cb	Pinkish earthenware	green	1	a tomb at Gushanzi village, Sanjia Township, Kazuo county, Liaoning Province	Kazuo museum, Chaoyang city, Liaoning province	Early	Cat. 476
Cb	Pinkish earthenware	green	1			Early	Cat. 477
Cb	Pinkish earthenware	green	1	a tomb at Xigou, Linjiadi Township, Aohan Banner, Inner Mongolia	Aohan Banner Museum, Inner Mongolia	early	Cat. 478
Cb	Pinkish earthenware	green	1		Collections of P.R. China	early	Cat. 479
Cb	Pinkish earthenware	yellow	1	ZWZ		1093	Cat. 480
Cb	Pinkish earthenware	yellow	1	ZKZ		1093	Cat. 481
Cb	Pinkish earthenware	yellow	1	ZSB		1115-1144	Cat. 482

Type	Body	Glaze	Amount	Unearthed From	Collected By	Date (AD)	Cat. No.
Cb	porcelain	white	1	LQW kiln site, Beijing	Research Institute of Relics of Beijing		Cat. 483
Cb	porcelain	white	1		Mengdiexuan Collection		Cat. 484
Cb	porcelain	?	1	LQW kiln site, Beijing	Research Institute of Relics of Beijing		Cat. 485
Cb	porcelain	?	1	LQW kiln site, Beijing	Research Institute of Relics of Beijing		Cat. 486
Cb	porcelain	?	1	LQW kiln site, Beijing	Research Institute of Relics of Beijing		Cat. 487
Cc	Porcelain	white	1	HQY6		late	Cat. 489
Cc	Porcelain	white	1	A tomb at Longjiang county, Heilongjiang province	Heilongjiang Wenwu kaogu dui	late	Cat. 488
Cd	Porcelain	white	1	a tomb at Nanlinzi, Liaoyang, Liaoning province	Liaoning Provincial Museum		Cat. 491

Type	Body	Glaze	Amount	Unearthed From	Collected By	Date (AD)	Cat. No.
Cd	Porcelain	white	1	a tomb at Balin Right Banner ,Inner Mongolia	Collections of P.R.China		Cat. 490
Cd	Porcelain	white	1	ZKY		1060	Cat. 492
Ce	Porcelain	white	1		Datong Municipal museum, Shanxi province		Cat. 493
							Cat. 494
Ce	Porcelain	white	1		Royal Ontario Museum, Toronto		Cat. 495
Ce	Porcelain	white	1		Royal Ontario Museum, Toronto		Cat. 496
Ce	Porcelain	white	1				Cat. 497
Ce	Porcelain	white	1	a hoard at Sangou village in Chengde city, Hebei Province			106

Type	Body	Glaze	Amount	Unearthed From	Collected By	Date (AD)	Cat. No.
Ce	Porcelain	white	1		Guan Baocong collection		Cat. 498
Cf	Buff stoneware	green	1	the Foundations of a pagoda at Dingxian, Hebei	Center of Asian Art and Culture, Avery Brundage Collection, San Francisco, California	977	Cat. 499
Cf	Buff stoneware	white	1	a tomb at Majiabao village, Datong city, Inner Mongolia	Datong municipal museum, Shanxi province		Cat. 500
Cf	porcelain	white			Museum of Far Eastern Antiquities: Carl Kempe Collection, Stockholm; Museum of Far Eastern Antiquities: Kempe Coll., Stockholm (386)		Cat. 501
Cf	Buff stoneware	green	1		Liaoning Provincial Museum	early	Cat. 502
Da	Pinkish earthenware	Three-colored	1	A tomb at Yusi Township, Fuxin city, Liaoning province	Fuxin municipal museum, Liaoning Province		Cat. 503
Da	Pinkish earthenware	Three-colored	1	A tomb at Kerzuo Central Banner, Inner Mongolia	Tongliao Municipal Museum, Inner Mongolia	late	Cat. 504

Type	Body	Glaze	Amount	Unearthed From	Collected By	Date (AD)	Cat. No.
Db	Pinkish earthenware	Three-colored	1	A tomb at Yushulinzi, Ningcheng County, Inner Mongolia	Chifeng municipal museum	late	Cat. 505
Db	Pinkish earthenware	Three-colored	1	A tomb at Ningcheng County, Inner Mongolia	Liaozhongjing Museum, Ningcheng county, Inner Mongolia	late	Cat. 506
Dc	porcelain	white	1		Tokyo National Museum		Cat. 507
Dc	Pinkish earthenware	Three-colored	1		The Palace Museum, Beijing	late	Cat. 508
Dd	Pinkish earthenware	Three-colored	1	A tomb at Wangjiadian, Chifeng, Inner Mongolia	Chifeng municipal museum, Inner Mongolia	late	Cat. 509
Dd	Pinkish earthenware	Three-colored	1	A tomb at Wangjiayingzi, Songshan district, Chifeng, Inner Mongolia	Chifeng municipal museum, Inner Mongolia	late	Cat. 510
Dd	Pinkish earthenware	Three-colored	1	A tomb at Yihefang of Lingyuan county, Liaoning	Liaoning Provincial museum	late	Cat. 511
De	Buff stoneware	green	1	A tomb at Tuchengzi site, Helinge'er county, Huhhot City, Inner Mongolia	Inner Mongolia Autonomous Region Museum	early	Cat. 512

Type	Body	Glaze	Amount	Unearthed From	Collected By	Date (AD)	Cat. No.
De	Buff stoneware	white	1		Xiwenguozhai collection		Cat. 513
Df	porcelain	white	1	A tomb at Wulantaohai, Bailin Left Banner, Inner Mongolia	Relics office of Chifeng city, Inner Mongolia		Cat. 514
Df	porcelain	white	1		British Museum, London		Cat. 515
Df	Pinkish earthenware	Three-colored	1		Sold by Sotheby's at New York on June, 1983	late	Cat. 516
Dg	Pinkish earthenware	Three-colored	1	A tomb at Yushulinzi, Ningcheng county, Inner Mongolia	Ningcheng Museum, Inner Mongolia	late	Cat. 517
Dh	Pinkish earthenware	Three-colored	1		Liaoning Provincial Museum	late	Cat. 518
Dh	Pinkish earthenware	Three-colored	1	A tomb at Changsheng Township, Aohan Banner, Inner Mongolia	Aohan Banner Museum, Inner Mongolia	late	Cat. 519
Di	Pinkish earthenware	Three-colored	1		The Palace Museum, Beijing	late	Cat. 520

Type	Body	Glaze	Amount	Unearthed From	Collected By	Date (AD)	Cat. No.
Dj	Pinkish earthenware	Three-colored	1		Royal Ontario Museum, Toronto	late	Cat. 521
Dk	porcelain	white	1	A tomb at Kulun Banner, Inner Mongolia	Zhelimu leagure Museum, Inner Mongolia		Cat. 522
DI	porcelain	white	1				Cat. 523
DI	porcelain	white	1		Guan Baocong collection		Cat. 524
Ea	Pinkish earthenware	green	1	GDG	Chifeng municipal museum		Cat. 525
Ea	stoneware	white	1	A tomb at Taiping village Hadayingge, Township, Balin Left Banner, Inner Mongolia	Liaoshangjing Museum, Inner Mongolia		Cat. 526
Eb	stoneware	green	1	A tomb at Songshan, Chifeng, Inner Mongolia	Relics office of Songshan district, Chifeng city, Inner Mongolia		Cat. 527
Ec	stoneware	yellow	1		Guan Baocong collection		Cat. 528

Type	Body	Glaze	Amount	Unearthed From	Collected By	Date (AD)	Cat. No.
Ed	stoneware	white	1	A tomb at Baitaigou, Fuxin city, Liaoning province	Liaoning Provincial Museum		Cat. 529
Ee	stoneware	White with brown iron pigment painted	1		Liaoning Provincial Museum	late	Cat. 530
E	stoneware	white	1	GGT kiln site, Liaoning	Guan Baocong collection	late	Cat. 531

TABLE 36 LIST OF UNEARTHED OBJECTS AND OTHER COLLECTIONS: CHICKEN-LEG VASE

Type	Body	Glaze	Amount	Unearthed From	Collected By	Date (AD)	Cat. No.
A	stoneware	black	1	HLDT2		early	Cat. 532
A	stoneware	Tea-dust green	2	SQ1	Liaoning provincial museum	middle	Cat. 533
A	stoneware	Tea-dust green	1	YMT22		middle	Cat. 534
A	stoneware	Tea-dust green	2	WDGM		late	Cat. 536
A	stoneware	Tea-dust green	2	HYM		1011	Cat. 535

Type	Body	Glaze	Amount	Unearthed From	Collected By	Date (AD)	Cat. No.
B	stoneware	Tea-dust green	2	YMT7	Liaoning provincial museum	977	Cat. 537
B	stoneware	Tea-dust green		BL1	Liaoning provincial museum	Middle	Cat. 539
B	stoneware	Tea-dust green	3	CGGZ	Inner Mongolia cultural relics and Archaeology institute	1018	Cat. 540
B	stoneware	Tea-dust green	1	YMT22		middle	Cat. 541
B	stoneware	Tea-dust green	2	a tomb at Chaoyanggou, Zhangwu county, Liaoning	Zhangwushi wenwu guanlisuo	951-969	Cat. 542
B	stoneware	Tea-dust green	2	SQ1	Liaoning provincial museum	middle	Cat. 543
B	stoneware	Tea-dust green	1	QHM4	Liaoning provincial museum	1032-1064	Cat. 544
B	stoneware	Black	1		Nelson-Atkins Gallery, Kansas city, Missouri	middle	Cat. 545
B	stoneware	Black	1		Guan Baocong collection	middle	Cat. 546
B	stoneware	Tea-dust green	1	QHZ		middle ? late?	Cat. 547
B	stoneware	Tea-dust green	1	QHZ		middle ? late?	Cat. 548
B	stoneware	Tea-dust green	2	GS1		late	Cat. 549
B	stoneware	Tea-dust green	1	MTYZ1		Early? Late?	Cat. 550

Type	Body	Glaze	Amount	Unearthed From	Collected By	Date (AD)	Cat. No.
B	stoneware	Tea-dust green			Liaoning provincial museum	1102	Cat. 551
B	stoneware	Tea-dust green	1		Royal Ontario Museum, Toronto	late	Cat. 552
B	stoneware	Tea-dust green	2	a tomb at Shuangjing township, Aohan Banner, Inner Mongolia	Aohan Banner Museum, Inner Mongolia	1101-1110	Cat. 553
B	stoneware	Tea-dust green	2	a tomb at Shanwan village, Biliutai township, Balin Left Banner, Inner Mongolia	Liaoshangjing museum, Inner Mongolia	1101-1110	Cat. 554
B	stoneware	Tea-dust green	1		Liaoning provincial museum	1101-1110	Cat. 555
B	stoneware	Black	1		Liaoning provincial museum	1101-1110	Cat. 556
B	stoneware	Tea-dust green	1		Royal Ontario Museum, Toronto	late	Cat. 557
B	stoneware	Black	1		Japanese collection	late	Cat. 558
B	stoneware	Tea-dust green	2	ZGY		1117	Cat. 559
B	stoneware	Tea-dust green	2	ZWZ(M7:21)		1093	Cat. 560
B	stoneware	Black	2	CGM		Late	Cat. 561
B	stoneware	Tea-dust green	1		Japanese collection		Cat. 562
B	stoneware	Tea-dust green	2	XHD		middle	Cat. 563

Type	Body	Glaze	Amount	Unearthed From	Collected By	Date (AD)	Cat. No.
B	stoneware	Tea-dust green	1		Liaoning provincial museum	late	Cat. 564
B	stoneware	Tea-dust green	1		Guan Baocong collection	late	Cat. 568

TABLE 37 LIST OF UNEARTHED OBJECTS AND OTHER COLLECTIONS: CHINESE STYLE VASE

Type	Body	Glaze	Amount	Unearthed From	Collected By	Date (AD)	Cat.No.
A	Stoneware	brown	1	YMT7	Liaoning Provincial Museum	977	Cat. 565
A	Stoneware	black	1	QHM4	Liaoning Provincial Museum	middle	Cat. 566
A	Stoneware	white	1	KL1		1080	Cat. 569
A	Stoneware	white	1		The Capital Museum, Beijing	late	Cat. 570
A	Stoneware	white	1		Liaoning Provincial Museum	late	Cat. 571
A	Stoneware	white	1		Liaoning Provincial Museum	late	Cat. 572
A	Stoneware	white	1		Datong Municipal Museum, Shanxi Province	late	Cat. 573
B	Porcelain	white	1	QHM2		1057	Cat. 574

Type	Body	Glaze	Amount	Unearthed From	Collected By	Date (AD)	Cat.No.
B	Porcelain	white	1	KL1		1080	Cat. 575
B	Porcelain	white	1	CDMM		late	Cat. 576
B	Porcelain	white	1	Tomb at Majiagou, Lingyuan County, Liaoning Province		late	Cat. 577
B	Porcelain	white	1	A tomb at Wushijiazi, Machang Township, Jianping County, Liaoning Province	Liaoning Provincial Museum	late	Cat. 578
B	Porcelain	white	1	Tomb at Yaojiagou, Jinchanggouliang Township, Aohan Banner, Inner Mongolia	Aohan Banner Museum, Inner Mongolia	Late	Cat. 579
B	Stoneware	brown	2	A tomb at Shakengzi, Mutouyingzi Township, Aohan Banner, Inner Mongolia	Aohan Banner Museum, Inner Mongolia	late	Cat. 580
B	Porcelain	white	1		Guan Baocong collection	late	Cat. 581
B	Stoneware	black	1		Guan Baocong collection	late	Cat. 582
C	Porcelain	white	1	HQY9		late	Cat. 583
C	unknown	unknown	1	SHZC		late	Cat. 584

Type	Body	Glaze	Amount	Unearthed From	Collected By	Date (AD)	Cat.No.
C	Stoneware	black	1	A tomb at Hurenbaohe village, Xinhui Township, Aohan Banner, Inner Mongolia.	Aohan Banner Museum, Inner Mongolia	late	Cat. 585
C	Stoneware	white	1	A tomb at Yezhushan, Mutouyingzi Township, Aohan Banner, Inner Mongolia	Aohan Banner Museum	late	Cat. 586
C	Porcelain	white	1		Guan Baocong collection	Late	Cat. 587
C	Stoneware	white	1		Guan Baocong collection	late	Cat. 588
C	Porcelain	white	1	A tomb at Zhagesitai, Alike'erqin Banner, Inner Mongolia		late	Cat. 589
C	Earthenware	yellow	1		Guan Baocong collection	late	Cat. 590
D	stoneware	white	1	Tomb at Chaoyanggou, Zhangwu City, Liaoning province	Relics office of Zhangwu, Liaoning	late	Cat. 591
D	stoneware	white	1	XJM	Research Institute of Cultural Relics and Archaeology of Liaoning province	1029	Cat. 592
D	stoneware	white	2	FJTGD	Relics office of Alike'erqin Banner, Inner Mongolia	late	Cat. 593
D	Stoneware	brown	1	HQY9		Late	Cat. 594
D	Stoneware	brown	1	PJG3		late	Cat. 595

Type	Body	Glaze	Amount	Unearthed From	Collected By	Date (AD)	Cat.No.
D	stoneware	white	1	GSZ1		late	Cat. 596
D	stoneware	white	1		Guan Baocong collection	late	Cat. 597

TABLE 38 LIST OF UNEARTHED OBJECTS AND OTHER COLLECTIONS: JAR

Type	Body	Glaze	Amount	Unearthed From	Collected By	Date (AD)	Cat. No.
Aa	Buff stoneware	green	2	HLB1		early	Cat. 599
Aa	Buff stoneware	brown	1	Tomb at Chaoyanggou, Zhangwu city, Liaoning Province	Zhangwu municipal relics office	early	Cat. 600
Aa	Buff stoneware	green	2	DQTL3		early	Cat. 601
Aa	Buff stoneware	green	2	DQTL3		early	Cat. 602
Aa	Porcelain	white	6	FMM		959	Cat. 603
Aa	Buff stoneware	green	1	CGGZ		1018	Cat. 604
Aa	Buff stoneware	brown	2		Liaoshangjing Museum, Inner Mongolia		Cat. 605
Aa	Pinkish earthenware	yellow	1	XLZZ1		late	Cat. 606
Aa	Pinkish earthenware	yellow	1		Liaoning provincial museum	Late	Cat. 607

Type	Body	Glaze	Amount	Unearthed From	Collected By	Date (AD)	Cat. No.
Aa	Pinkish earthenware	white	1		Privat collection	Late	Cat. 608
Aa	Pinkish earthenware	yellow	1	ZTM		Late	Cat. 609
Aa	Stoneware	white	1		Guan Baocong collection	Late	Cat. 610
Aa	Stoneware	white	1	Kalaqin Banner, Chifeng City, Inner Mongolia	Inner Mongolia autonomous region museum	Late	Cat. 611
Aa	Stoneware	white	1	Songshan District, Chifeng City, Inner Mongolia	Qongshan relics office, Chifeng city, Inner Mongolia	Late	Cat. 612
Aa	Stoneware	white	1	The Gacha site at Baogutu Township, Aohan Banner, Inner Mongolia	Aohan Banner museum	Late	Cat. 613
Aa	Stoneware	white	1		Liaoning provincial museum	late	Cat. 614
Aa	Stoneware	white	1	Taipingchi commune of Chifeng city, Inner Mongolia	Liaoning provincial museum	late	Cat. 615
Aa	Stoneware	white	1		Center of Asian Art and Culture, Avery Brundage Collection, San Francisco, California	late	Cat. 616
Aa	Stoneware	white	1		Idemitsu Art Gallery, Tokyo		Cat. 617
Aa	Stoneware	white	1		Idemitsu Art Gallery, Tokyo 出光美术馆?		Cat. 618
Aa	Stoneware	white	1	GWYC kiln site			Cat. 619

Type	Body	Glaze	Amount	Unearthed From	Collected By	Date (AD)	Cat. No.
Aa	Stoneware	white	1	Liao site at Nantaizi, Kalaqin Banner, Inner Mongolia			Cat. 620
Aa	Stoneware	white	1		Idemitsu Art Gallery, Tokyo		Cat. 621
Aa	Stoneware	white	1		Nelson-Atkins Gallery, Kansas City, Missouri	Late	Cat. 622
Aa	Stoneware	white	1		Guan Baocong collection	Late	Cat. 623
Ab	Porcelain	white	1	FMM		959	Cat. 624
Ab	Pinkish earthenware	green	1	XHD		middle	Cat. 626
Ab	Porcelain	white	1	YLYZ		942	Cat. 627
Ab	Porcelain	white	1		Guan Baocong collection		Cat. 628
Ab	Porcelain	white	1	HYM		997	Cat. 629
Ab	Porcelain	white	1	GYG		1020	Cat. 630
Ab	Pinkish earthenware	green	1	A tomb at Xigou, Linjiadi Township, Aohan Banner, Inner Mongolia	Aohan Banner Museum		Cat. 631
Ab	Porcelain	white	1		Guan Baocong collection		Cat. 632
Ab	Porcelain	white	1		Guan Baocong collection		Cat. 633
Ab	Porcelain	white	1	TZM2			Cat. 634
							29
Ba	Stoneware	White	1	HLB1		early	Cat. 635

Type	Body	Glaze	Amount	Unearthed From	Collected By	Date (AD)	Cat. No.
Ba	Pinkish earthenware	green	1	XHD		middle	Cat. 637
Bb	Buff stoneware	brown	1	YLYZ		942	Cat. 638
Bb	Pinkish earthenware	green	1		Privat collection		Cat. 639
Bb	Pinkish earthenware	Three-colored	1	Idemitsu Museum of Art, Tokyo			Cat. 640
Bb	Porcelain	white	1	XJM	Liaoning cultural relics research institute	997-1021	Cat. 641
Bb	Buff stoneware	green	1		Center of Asian Art and Culture, Avery Brundage Collection, San Francisco, California		Cat. 642
Bb	Porcelain	white	1	NZLYZ1		early	Cat. 643
Bb	Pinkish earthenware	green	3	QHM2		1057	Cat. 646
Bb	stoneware	white	1	A tomb at Xiaoxigou, Niuyingzi Township, Kalaqin Banner, Inner Mongolia			Cat. 647
Bb	Pinkish earthenware	green	1	QDC		1078	Cat. 648
Bb	Pinkish earthenware	yellow	1	QDC		1078	Cat. 649
Bb	stoneware	white	1		Guan Baocong collection		Cat. 650

Type	Body	Glaze	Amount	Unearthed From	Collected By	Date (AD)	Cat. No.
Bb	stoneware	white	1	SHZC			Cat. 651
Bb	stoneware	black	1	A tomb at liaoyang city, Liaoning province	Liaoning provincial museum	late	Cat. 652
Bc	Porcelain	white	4	HYM		997	Cat. 653
Bc	Porcelain	white	1	SJG1		1002	Cat. 654
Bc	Porcelain	white	3	Pagoda JGS		1013	Cat. 655
Bc	Porcelain	white	1	CGGZ	Research institute of cultural relics and archaeology of Inner Mongolia	1018	Cat. 657
Bc	Porcelain	white	1	SQ1	Liaoning provincial museum		Cat. 659
Bc	Porcelain	white	1		Royal Ontario Museum, Toronto		Cat. 660
Bc	Porcelain	white	1	LQW kiln site	Beijing cultural relics research institute		Cat. 661
Bc	Porcelain	white	1	LQW kiln site	Beijing cultural relics research institute		Cat. 662
Bc	Porcelain	white	1	LQW kiln site	Beijing cultural relics research institute		Cat. 663
Bc	Buff stoneware	white	1		Liaoning Provincial Museum		Cat. 664
Bc	Buff stoneware	white	1	YS1		late	Cat. 666
Bc	Buff stoneware	white	1	WZM		1053	Cat. 667
Bc	Buff stoneware	white	1		Guan Baocong collection		Cat. 668
Bd	Porcelain	white	1		The Cleveland Museum of Art, John L. Severance Foundation		Cat. 669
Bd	Porcelain	brown	1	YLYZ		942	Cat. 670
Bd	Porcelain	white	1	XBTB (MWG4)		1069-1081	Cat. 671

Type	Body	Glaze	Amount	Unearthed From	Collected By	Date (AD)	Cat. No.
Bd	Stoneware	white	1		Guan Baocong collection	late	Cat. 672
Bd	Stoneware	white	1	A tomb at Jijiyingzi, Shuangjingzi Township, Aohan Banner, Inner Mongolia	Aohan Banner Museum, Inner Mongolia	late	Cat. 673
Bd	Stoneware	white	1		Shanghai Museum	late	Cat. 674
Bd	Stoneware	white	1		The Metropolitan Museum of Art, New York		Cat. 675
Bd	Stoneware	white	1		Shanghai museum	late	Cat. 676
Bd	Stoneware	white	1		Kazoo museum, Chaoyang city, Liaoning province	late	Cat. 677
Bd	Stoneware	white	1	Chifeng City, Inner Mongolia			Cat. 678
Bd	Stoneware	white	1	A Liao site at Chengzi Township, Chifeng city, Inner Mongolia	Chifeng municipal museum	late	Cat. 679
Bd	Buff stoneware	white	1	QCY kiln site at Datong, Shanxi province	Datong municipal museum	1102	Cat. 680
Bd	Buff stoneware	white	1	At a tomb at Datong, Shanxi province	Datong municipal museum	1102	Cat. 681
Ca	Buff stoneware	green	1		Center of Asian Art and Culture, Avery Brundage Collection, San Francisco, California		Cat. 682
Ca	Stonware	white	1	XTM(MWG3)		1070	Cat. 683
Cb	Porcelain	white	1	JSM		late	Cat. 686

Type	Body	Glaze	Amount	Unearthed From	Collected By	Date (AD)	Cat. No.
Da	Stoneware	white	1	Nailingao, Aohan Banner, Inner Mongolia	Aohan Banner Museum, Inner Mongolia	late	Cat. 687
Da	Stoneware	white	1	Nailingao, Aohan Banner, Inner Mongolia	Aohan Banner Museum, Inner Mongolia	late	Cat. 688
Da	Stoneware	white	1		Guan Baocong collection	late	Cat. 689
Da	Pinkish earthenware	yellow	1		Guan Baocong collection	late	Cat. 690
Da	Stoneware	white	1			late	Cat. 691
Da	Stoneware	white	1		Guan Baocong collection	late	Cat. 692
Da	Stoneware	white	1	PJG		late	Cat. 693
Da	Stoneware	white	1		Liaoning provincial museum	late	Cat. 694
Da	Stoneware	white	1		Liaoning provincial museum	late	Cat. 695
Db	Stoneware	white	2		Guan Baocong collection	late	Cat. 696

TABLE 39 LIST OF UNEARTHED OBJECTS AND OTHER COLLECTIONS: BASIN

Type	Body	Glaze	Amount	Unearthed From	Collected By	Date (AD)	Cat. No.
A	Buff stoneware	green	1	DQTL3		early	Cat. 697
A	Pinkish earthenware	yellow	1	QHZ		Middle	Cat. 698
A	stoneware	Tea-dust green	1	SQ1		Middle	Cat. 699
A	Pinkish earthenware	green	1	DXG1		middle	Cat. 700

Type	Body	Glaze	Amount	Unearthed From	Collected By	Date (AD)	Cat. No.
A	stoneware	white	1	FMM		959	Cat. 701
A	stoneware	white	1	CGGZ		1018	Cat. 702
A	Pinkish earthenware	yellow	1	BL3		late	Cat. 703
A	Pinkish earthenware	yellow	1	JFYZ		late	Cat. 704
A	Pinkish earthenware	white	1	QHM2		1057	Cat. 705
A	Pinkish earthenware	yellow	1	Tomb at Kangjiazhangzi, Jianpin, Liaoning province	Research Institute of Cultral relics and archaeology of Liaoning Province		Cat. 706
A	Stoneware	White	1		Guan Baocong collection		Cat. 707
A	Pinkish earthenware	green	1		Provate collection		Cat. 708
A	Pinkish earthenware	yellow	1		Guan Baocong collection		Cat. 709
A	Pinkish earthenware	Yellow and green	1	XLZZ1		late	Cat. 710
A	Stoneware	White	1		Guan Baocong collection		Cat. 711

Type	Body	Glaze	Amount	Unearthed From	Collected By	Date (AD)	Cat. No.
A	Stoneware	White	1		Liaoning tieling qunzhongyishuguan wenwuzu		Cat. 712
A	Stoneware	White	1		Liaoning provincial museum		Cat. 713
A	Pinkish earthenware	Three-col ored	1	XLC			Cat. 714
A	Pinkish earthenware	Yellow and green	1	ZSB		1115-1144	Cat. 715
A	Pinkish earthenware	Yellow and green	1	ZWZ		1093	Cat. 716
B	Buff stoneware	green	1	DQTL3		early	Cat. 718
B	Pinkish earthenware	green	1	QCH		middle	Cat. 719
B	Pinkish earthenware	green	1		Guan Baocong collection		Cat. 720
	Gold		1	CGGZ		1018	Cat. 721
B	Pinkish earthenware	green	1	YMT22		middle	Cat. 722
B	Pinkish earthenware	white	1	HTH1		middle	Cat. 723

Type	Body	Glaze	Amount	Unearthed From	Collected By	Date (AD)	Cat. No.
B	Pinkish earthenware	green	1	LBB		Early?	Cat. 724
B	Pinkish earthenware	green	1	XHD			Cat. 725
B	Pinkish earthenware	green	1	A tomb at Heping dadui, Dayingzi, Linxi county, Inner Mongolia			Cat. 726
B	Pinkish earthenware	white	1	DSLT1			Cat. 727
B	Pinkish earthenware	white	1		Guan Baocong collection		Cat. 728
B	Pinkish earthenware	white	1	CGB11			Cat. 729
B	Pinkish earthenware	white	1	A tomb at Beishan, Aluke'erqin Banner, Inner Mongolia			Cat. 730
B	Pinkish earthenware	white	1	CKTDS4	Chifeng municipal museum, Inner Mongolia		Cat. 731
B	Pinkish earthenware	white	1		Guan Baocong collection		Cat. 732
B	Pinkish earthenware	white	1		Guan Baocong collection		Cat. 733
B	Pinkish earthenware	white	1	a tomb at Yimatu, Beizifu township, Aohan Banner, Inner Mongolia	Aohan Banner Museum, Inner Mongolia		Cat. 734

Type	Body	Glaze	Amount	Unearthed From	Collected By	Date (AD)	Cat. No.
B	Pinkish earthenware	white	1	A tomb at Shuangsheng village, Longchang township, Balin Left Banner, Inner Mongolia	Liaoshangjing Museum, Inner Mongolia		Cat. 735
B	Pinkish earthenware	white	1		Private collection		Cat. 736
B	Pinkish earthenware	white	1		Private collection		Cat. 737
B	Pinkish earthenware	white	1	YMT2	Liaoning provincial museum		Cat. 738
B	Pinkish earthenware	white	1		Liaoning provincial museum		Cat. 739
B	Pinkish earthenware	white	1		Private collection		Cat. 740
B	Pinkish earthenware	white	1	A tomb at Yousheng village, Baiyin'aobao township, Balin Left Banner, Inner Mongolia	Liaoshangjing museum, Inner Mongolia		Cat. 741
B	Pinkish earthenware	white	1		Guan Baocong collection		Cat. 742
B	Pinkish earthenware	white	1		Liaoning provincial museum		Cat. 743
B	Pinkish earthenware	white	1		Mengdiexuan collection		Cat. 744
B	Stoneware	white	1		Museum of Tongliao city, Inner Mongolia		Cat. 745

Type	Body	Glaze	Amount	Unearthed From	Collected By	Date (AD)	Cat. No.
B	Pinkish earthenware	white	1		Mengdiexuan collection		Cat. 746
B	Pinkish earthenware	white	1	A tomb at Xishan of Yemaotai in Faku county, Liaoning Province	Liaoning provincial museum		Cat. 747
B	Pinkish earthenware	white	1	FJTGX	Chifeng municipal museum	late	Cat. 748
B	Pinkish earthenware	white	2	WJS1	Chifeng municipal museum	late	Cat. 749
B	Pinkish earthenware	white	1	XSC7		late	Cat. 750

TABLE 40 LIST OF UNEARTHED OBJECTS AND OTHER COLLECTIONS: SPITTOON

Type	Body	Glaze	Amount	Unearthed From	Collected By	Date (AD)	Cat. No.
	Gilt silver		1		Research institute of cultural relics and Archaeology of Inner Mongolia	early	Cat. 751
	silver		1	CGGZ	Zhelimumeng museum, Inner Mongolia	1018	Cat. 752
	Grass		1	BL1	Liaoning provincial museum		Cat. 753
A	Buff stoneware	green	1	DQTL3		early	Cat. 754
A	Pinkish earthenware	green	1	XHD		middle	Cat. 755

Type	Body	Glaze	Amount	Unearthed From	Collected By	Date (AD)	Cat. No.
A	Pinkish earthenware	green	1	ELC		middle	Cat. 756
A	Stoneware	green	1	A tomb at Kangjiazhangzi, Jianping city, Liaoning province	Research institute of cultural relics and archaeology of Liaoning province	middle	Cat. 757
A	Pinkish earthenware	green	1	YWG	Luanping museum, Hebei province	Middle	Cat. 758
A	Pinkish earthenware	yellow	1		Guan Baocong collection		Cat. 759
A	Pinkish earthenware	white	1		Guan Baocong collection		Cat. 760
A	Pinkish earthenware	white	1	QHM4			Cat. 761
A	Pinkish earthenware	green	1	XSC4		late	Cat. 763
A	Pinkish earthenware	yellow	1		Guan Baocong collection		Cat. 764
A	Pinkish earthenware	yellow	1	PJG3		late	Cat. 765
A	Pinkish earthenware	yellow	1	TJYZ		late	Cat. 766
A	Pinkish earthenware	yellow	1		Guan Baocong collection		Cat. 767
A	Pinkish earthenware	yellow	1		Liaoning provincial museum		Cat. 768

Type	Body	Glaze	Amount	Unearthed From	Collected By	Date (AD)	Cat. No.
A	Pinkish earthenware	yellow	1		Liaoning provincial museum		Cat. 769
A	Pinkish earthenware	yellow	1	XLZZ3		late	Cat. 770
A	Porcelain	black	1		Guan Baocong collection		Cat. 771
AV	Pinkish earthenware	green	1		Guan Baocong collection		Cat. 772
AV	Pinkish earthenware	yellow	1		Guan Baocong collection		Cat. 773
AV	Pinkish earthenware	Yellow	1		Aohan Banner Museum, Inner Mongolia		Cat. 774
AV	Pinkish earthenware	green	1	XLZZ4			Cat. 775
AV	Pinkish earthenware	yellow	1		The Place museum, Beijing		Cat. 776
AV	Pinkish earthenware	yellow	1	ZSQ	Hebei provincial museum	1116	Cat. 777
AV	Pinkish earthenware	yellow	1	ZWZ		1093	Cat. 778
AV	Pinkish earthenware	yellow	1	ZSB		1089-1144.	Cat. 779
AV	Pinkish earthenware	yellow	1	ZKZ		1093	Cat. 780

Type	Body	Glaze	Amount	Unearthed From	Collected By	Date (AD)	Cat. No.
AV	Pinkish earthenware	white	1		Guan Baocong collection		Cat. 781
A	Pinkish earthenware	yellow	1	XDM		late	Cat. 782
A	Pinkish earthenware	green	1	HPYZ1		late	Cat. 783
B	Pinkish earthenware	green	1	QCH	Liaoning provincial museum	middle	Cat. 784
B	Pinkish earthenware	yellow	1	DSLT1		middle	Cat. 785
B	Pinkish earthenware	white	1	WJS1	Chifen municipal museum	late	Cat. 786
B	Pinkish earthenware	green	1		Guan Baocong collection		Cat. 787
B	Pinkish earthenware	white	1		Guan Baocong collection		Cat. 788
C	Porcelain	white	1	HYM		997	Cat. 789
C	Porcelain	white	1		Guan Baocong collection		Cat. 790
C	Pinkish earthenware	White glaze with green painted	1	A tomb at Xinlin village, Xianfeng Township, Alike'erqin Banner, Inner Mongolia			Cat. 791

Type	Body	Glaze	Amount	Unearthed From	Collected By	Date (AD)	Cat. No.
C	Pinkish earthenware	White glaze with green and yellow painted	1	A tomb at Erbadi village, Yangchang Township, Balin Right Banner, Inner Mongolia	Baling Right Banner Museum, Inner Mongolia		Cat. 792
D	Stoneware	white	1		Liaoning Provincial Museum		Cat. 793

TABLE 41 LIST OF UNEARTHED OBJECTS AND OTHER COLLECTIONS: SAUCER

Type	Body	Glaze	Amount	Unearthed From	Collected By	Date (AD)	Cat. No.
A	Stoneware	green	1	DQTL3		early	Cat. 794
A	Pinkish earthenware	green	1	HLB1		early	Cat. 795
A	Pinkish earthenware	white	1	HLB1		early	Cat. 796
A	Pinkish earthenware	green	1	A tomb at Yebaishou station, Jianping city, Liaoning Province	Liaoning Provincial Museum	early	Cat. 797
A	Pinkish earthenware	Green	1	QCH		1004	Cat. 799
A	Pinkish earthenware	yellow	1	ZJYZ			Cat. 800

Type	Body	Glaze	Amount	Unearthed From	Collected By	Date (AD)	Cat. No.
A	porcelain	white	1	A tomb at Yimawen, Beizifu Township, Aohan Banner, Inner Mongolia	Aohan Museum, Inner Mongolia		Cat. 801
A	porcelain	white		LQW kiln site			Cat. 802
A	porcelain	white	1	A tomb at Hadatu village, Hadayingge Township, Balin Left Banner, Inner Mongolia	Liaoshangjing Museum, Inner Mongolia		Cat. 803
B	porcelain	white		DQTL3		early	Cat. 804
B	porcelain	white	1	YLYN	Liaoning Provincial Museum	986	Cat. 808
B	Pinkish earthenware	Green with yellow pigment	1	JCY		994	Cat. 798
B	porcelain	white	1	A tomb at Hadatu village, Hadayingge Township, Balin Left Banner, Inner Mongolia	Liaoshangjing Museum, Inner Mongolia		Cat. 805
B	porcelain	white	1	SQ1	Liaoning Provincial Museum		Cat. 806
B	porcelain	white	1		Guan Baocong collection		Cat. 807
Ca	Pinkish earthenware	white	1	BL4		middle	Cat. 809

Type	Body	Glaze	Amount	Unearthed From	Collected By	Date (AD)	Cat. No.
Ca	porcelain	white	1	HXM		1017	Cat. 810
Ca	Pinkish earthenware	white	1		Guan Baocong collection		Cat. 812
Ca	Pinkish earthenware	yellow	1	ZSB		1115-1144	Cat. 813
Ca	Pinkish earthenware	yellow	1	ZWZ		1093	Cat. 814
Ca	Pinkish earthenware	yellow	1	ZSB		1089-1144	Cat. 815
Ca	porcelain	white	1		Inner Mongolia autonomous region museum		Cat. 816
Ca	Pinkish earthenware	yellow	1	XLZZ4		late	Cat. 817
Ca	Pinkish earthenware	brown	1	BTYZ		late	Cat. 818
Ca	Pinkish earthenware	brown	1	XFJ		1072	Cat. 819
Ca	Pinkish earthenware	yellow	1		Guan Baocong collection	late	Cat. 820
Ca	Pinkish earthenware	yellow	1		Guan Baocong collection	late	Cat. 821
Ca	Pinkish earthenware	yellow	1		Liaoning Provincial Museum	late	Cat. 822

Type	Body	Glaze	Amount	Unearthed From	Collected By	Date (AD)	Cat. No.
Ca	Pinkish earthenware	yellow	1		Chifeng Municipal Museum	late	Cat. 823
Ca	Pinkish earthenware	yellow	1		Liaoning provincial museum	late	Cat. 824
Ca	silver		1	CGGZ		1018	Cat. 825
Cb	Pinkish earthenware	green	2	JFYZ	Chifeng municipal museum	late	Cat. 826
Cb	Pinkish earthenware	yellow	1		Guan Baocong collection	late	Cat. 827
D	porcelain	black	2		Guan Baocong collection	late	Cat. 828
D	porcelain	white	1	A tomb at Yongdingmenwai, Beijing	Capital Museum, Beijing		Cat. 829
D	Pinkish earthenware	green	2		Guan Baocong collection		Cat. 830
E	Pinkish earthenware	green		LQW kiln site			Cat. 831

TABLE 42 LIST OF UNEARTHED OBJECTS AND OTHER COLLECTIONS: RING-FOOT BOWL

Type	Body	Glaze	Amount	Unearthed From	Collected By	Date (AD)	Cat.No.
Aa	Porcelain	white	2	DQTL3		early	Cat. 832

Type	Body	Glaze	Amount	Unearthed From	Collected By	Date (AD)	Cat.No.
Aa	Porcelain	white	2	SZG1		early	Cat. 833
Aa	Porcelain	white	1	A tomb at Sunjiawan, Chaoyang city, Liaoning province		Early?	Cat. 834
Aa	Stoneware	white	2	BL1	Liaoning provincial Museum	middle	Cat. 835
Aa	Stoneware	white	1	SLG6		middle	Cat. 836
Aa	Pinkish earthenware	white	1	CGWS		early	Cat. 837
Aa	Stoneware	white	1	GZX		1027	Cat. 838
Aa	Pinkish earthenware	white	1			997	Cat. 839
Aa	Stoneware	white	1	XHD		middle	Cat. 840
Aa	Porcelain	white	2	YWG		middle	Cat. 841
Aa	Porcelain	white	2	DXG1		middle	Cat. 842
Aa	Porcelain	white	7	YMT8		late	Cat. 843
Aa	Porcelain	white	1	Sanshan township, Balin Left banner	Liaoshangjing Museum, Inner Mongolia		Cat. 845

Type	Body	Glaze	Amount	Unearthed From	Collected By	Date (AD)	Cat.No.
Aa	Porcelain	white	1	AXZ		middle	Cat. 846
Aa	Porcelain	white	1	CKTDS4	Chifeng Municipal Museum, Inner Mongolia	late	Cat. 847
Aa	Porcelain	white	1	Tomb at Kangjiazhangzi, Jianping City, Liaoning Province M2:22	Research institute of cultural relics and archaeology of Liaoning Province	middle	Cat. 848
Aa	Stoneware	white	2	ELC		middle	Cat. 849
Aa	Stoneware	white	1	ZKY		1060	Cat. 850
Aa	Stoneware	white	1	CGC		late	Cat. 851
Aa	Pinkish earthenware	yellow	1		Liaoning Tieling qunzhongyishuguan wenwuzu	late	Cat. 852
Aa	Stoneware	white	1	A tomb at Beizifu Township, Aohan Banner, Inner Mongolia	Aohan Banner Museum, Inner Mongolia	late	Cat. 853
Aa	Porcelain	white	1	YS1		late	Cat. 854
Aa	Porcelain	white	2	QHZ		late	Cat. 855
Aa	Porcelain	white	5	XNRM		middle	Cat. 856
Aa	Stoneware	white	1	YS3		late	Cat. 857

Type	Body	Glaze	Amount	Unearthed From	Collected By	Date (AD)	Cat.No.
Aa	Porcelain	white	1	XSC4		late	Cat. 858
Aa	Porcelain	white	1	CGB11		middle	Cat. 859
Aa	Stoneware	white	3	GSZ2		?	Cat. 860
Aa	Pinkish earthenware	green	1	FJTGX		late	Cat. 861
Aa	Stoneware	white	1	GMZ		late	Cat. 862
Aa	Stoneware	white	1	ZDB		Early?	Cat. 863
Aa	Stoneware	white	1	QDC		1078	Cat. 864
Aa	Stoneware	white	2	MJ1		late	Cat. 865
Aa	Stoneware	white	16	KL6		late	Cat. 866
Aa	Porcelain	white	1	YMT8		late	Cat. 867
Aa	Stoneware	white	1	HQYZ3		late	Cat. 868
Aa	Stoneware	white	1		Guan Baocong collection	late	Cat. 869

Type	Body	Glaze	Amount	Unearthed From	Collected By	Date (AD)	Cat.No.
Aa	Stoneware	white	1		Guan Baocong collection	late	Cat. 870
Aa	Stoneware	white	1		Guan Baocong collection	late	Cat. 871
Aa	Stoneware	white	1		Guan Baocong collection	late	Cat. 872
Aa	Stoneware	white	1		Guan Baocong collection	late	Cat. 873
Aa	Stoneware	white	1		Guan Baocong collection	late	Cat. 874
Aa	Stoneware	white	1		Guan Baocong collection	late	Cat. 875
Aa	Stoneware	white	1		Guan Baocong collection	late	Cat. 876
Aa	Stoneware	brown	1	XFJ		1072	Cat. 877
Aa	Porcelain	white	2	Tomb at Kangjiazhangzi, Jianping city, Liaoning Province	Research institute of cultural relics and archaeology of Liaoning province	middle	Cat. 878
Aa	Stoneware	white	2	CDMM			Cat. 879
Aa	Stoneware	white	1		Liaoning Provincial Museum	late	Cat. 880

Type	Body	Glaze	Amount	Unearthed From	Collected By	Date (AD)	Cat.No.
Aa	Porcelain	brown	2	A tomb at Shibeicun, Baiyinchang Township, Naiman Banner, Inner Mongolia	Tongliao Municipal Museum, Inner Mongolia	late	Cat. 881
Aa	Stoneware	white	1		Liaoning Provincial Museum	late	Cat. 882
Aa	Stoneware	white	1		Liaoning Provincial Museum	late	Cat. 883
Aa	Porcelain	white	1	YMT ?	Liaoning Provincial Museum		Cat. 884
Aa	Porcelain	white	2	Tomb of Xiaohe at Fuxin city, Liaoning Province	Research institute of Cultrual relics and Archaeology of Liaoning Province	Middle	Cat. 885
Aa	Porcelain	white	2	XFJ		1072	Cat. 886
Aa	Stoneware	white	1	TJYZ		late	Cat. 887
Aa	Stoneware	white	2	CKTDS4	Chifeng Municipal Museum, Inner Mongolia	late	Cat. 888
Aa	Porcelain	white	1	WFG		late	Cat. 889
Aa	Porcelain	white	1	WFG		late	Cat. 890
Aa	Stoneware	white	1	MJ1		late	Cat. 891

Type	Body	Glaze	Amount	Unearthed From	Collected By	Date (AD)	Cat.No.
Aa	Pinkish earthenware	green	2	JFYZ		late	Cat. 892
Aa	Porcelain	white	9	Tomb of Xiaohe at Fuxin City, Liaoning Province		Middle	Cat. 893
Aa	Pinkish earthenware	yellow	1			late	Cat. 894
Aa	Pinkish earthenware	green	1	JFYZ	Chifeng Municipal Museum	late	Cat. 895
Ab	Porcelain	white	1	ZLK		early	Cat. 896
Ab	Porcelain	white	1	YLYZ		942	Cat. 897
Ab	Porcelain	white	1	HLB1		early	Cat. 898
Ab	Porcelain	white	1	XSC?		late	Cat. 899
Ab	Pinkish earthenware	yellow	1			late	Cat. 900
	Gold		1		Inner Mongolia autonomous region museum	Xixia	Cat. 901
Ab	Porcelain	white	2	YWG		Middle	Cat. 902

Type	Body	Glaze	Amount	Unearthed From	Collected By	Date (AD)	Cat.No.
Ab	Porcelain	white	1	Tomb at Chaoyanggou, Zhangwu city, Liaoning province	Relics office of Zhangwu city, Liaoning province	early	Cat. 903
Ab	Porcelain	white	2	HYM		997	Cat. 904
Ab	Porcelain	white	1	WZM		1053	Cat. 905
Ab	Stoneware	white	1		Guan Baocong collection		Cat. 906
Ab	Porcelain	white	2	PJG3		late	Cat. 907
Ab	Porcelain	white	1	Pagoda CYBTDG		1044	Cat. 908
Ab	Porcelain	white	1	CDM		late	Cat. 909
Ab	Porcelain	white	2	GS1		late	Cat. 910
Ab	Porcelain	white	1	ZWZ		1093	Cat. 911
Ba	Porcelain	white	1	BS1		923	Cat. 912
Ba	Porcelain	white	1	SJG1		1002	Cat. 913
Ba	Stoneware	white	1	ABEGE		early	Cat. 914

Type	Body	Glaze	Amount	Unearthed From	Collected By	Date (AD)	Cat.No.
Ba	Stoneware	white	1	YMT22		middle	Cat. 915
Ba	Stoneware	white	1	ZJY1		early	Cat. 916
Ba	Stoneware	white	1		Guan Baocong collection		Cat. 917
Ba	Pinkish earthenware	green	1	XDM	Chifeng Municipal Museum	late	Cat. 918
Ba	Stoneware	white	1	BL4		middle	Cat. 919
Ba	Stoneware	white	1	XSC9		late	Cat. 920
Ba	Porcelain	white	1	HQYZ6		late	Cat. 921
Ba	Stoneware	white	1	BTZ		late	Cat. 922
Ba	Stoneware	white	1	WJF		early	Cat. 923
Ba	Stoneware	white	1	FJTGX		late	Cat. 924
Ba	Pinkish earthenware	yellow	1	Tomb at Nanhuang, Nanta Township, Aohan Banner, Inner Mongolia	Aohan Banner Museum, Inner Mongolia	late	Cat. 925

Type	Body	Glaze	Amount	Unearthed From	Collected By	Date (AD)	Cat.No.
Ba	Stoneware	white	1	YS1		late	Cat. 926
Ba	Stoneware	white	1	WLHD		late	Cat. 927
Ba	Stoneware	white	2	YWG		Middle	Cat. 928
Ba	Stoneware	white	1	CDMM		late	Cat. 929
Ba	Stoneware	white	1	ZWZ		1093	Cat. 930
Ba	Stoneware	white	1	Tomb at Sijiazi, Fuxin city, Liaoning Province		late	Cat. 931
Ba	Stoneware	white	1	Tomb at Sijiazi, Fuxin city, Liaoning Province		late	Cat. 932
Ba	Stoneware	white	16	KL6		late	Cat. 933
Ba	Stoneware	white	1	A tomb at Dalaming'anla of Meilihe commune in Chifeng City, Inner Mongolia	Chifeng Municipal Museum, Inner Mongolia		Cat. 717
Ba	Stoneware	white	2	MJ1		late	Cat. 934
Ba	Pinkish earthenware	green	1	XHD		late	Cat. 935
Ba	Pinkish earthenware	yellow	2	FJTGX		late	Cat. 936

Type	Body	Glaze	Amount	Unearthed From	Collected By	Date (AD)	Cat.No.
Ba	Pinkish earthenware	yellow	1	ZKZ		1093	Cat. 937
Ba	Pinkish earthenware	yellow	1	ZWZ? ZKZ?		1093	Cat. 938
Ba	Stoneware	white	1	BTYZ			Cat. 940
Ba	Pinkish earthenware	Three-colored	1			late	Cat. 941
Ba	Pinkish earthenware	yellow	1		Guan Baocong collection	late	Cat. 942
Ba	Pinkish earthenware	green	1			late	Cat. 943
Ba	Pinkish earthenware	yellow	1		Guan Baocong collection	late	Cat. 979
Bb	Stoneware	white	1	GMZ		late	Cat. 944
Bb	Porcelain	white	2	HLDT2		early	Cat. 945
Bb	Porcelain	white	1	BL4		Middle	Cat. 946
Bb	Porcelain	white	2	YLYN		986	Cat. 947
Bb	Porcelain	white	1	CGB11		Middle	Cat. 948

Type	Body	Glaze	Amount	Unearthed From	Collected By	Date (AD)	Cat.No.
Bb	Porcelain	white	1	QCH		middle	Cat. 949
Bb	Porcelain	white	2	ZGY		1117	Cat. 950
Bb	Porcelain	white	3	ZWZ		1093	Cat. 951
Ca	Stoneware	white	1	SJG1		1002	Cat. 952
Ca	Stoneware	white	1		Liaoning Provincial Museum	late	Cat. 953
Ca	Stoneware	white	1		Guan Baocon collection		Cat. 954
Ca	Stoneware	white	1		Guan Baocon collection		Cat. 955
Ca	Pinkish earthenware	yellow	1	JFYZ		late	Cat. 956
Ca	Stoneware	white	1	BL4		Middle	Cat. 957
Ca	Stoneware	white	1	Tomb at Chaoyanggou, Zhangwu City, Liaoning Province (M3:3)	Relics office of Zhanwu city, Liaoning Province	early	Cat. 958
Ca	Stoneware	brown	1		LQW kiln site	?	Cat. 959
Ca	Stoneware	white	1		LQW kiln site	?	Cat. 960

Type	Body	Glaze	Amount	Unearthed From	Collected By	Date (AD)	Cat.No.
Ca	Stoneware	white	1	A tomb at Chenggou, Fuxin City, Liaoning Province	Fuxin Municipal Museum	late	Cat. 961
Ca	Stoneware	white	1	Tomb at Kangjiazhangzi, Jianping City, Inner Mongolia	Research institute of cultural relics and archaeology of Liaoning Province		Cat. 962
Ca	Stoneware	white	1			late	Cat. 963
Ca	Stoneware	white	1	FZZ		late	Cat. 965
Ca	Stoneware	white	1			late	Cat. 966
Ca	Stoneware	brown	1	Tomb at Sidaowanzi Township, Aohan Banner, Inner Mongolia	Aohan Banner Museum, Inner Mongolia		Cat. 967
Ca	Stoneware	white	1	GTT kiln site	Guan Baocong collection	late	Cat. 968
Ca	Stoneware	white	1	GTT kiln site	Guan Baocong collection	late	Cat. 969
Ca	Stoneware	white	1		Liaoning Provincial Museum	late	Cat. 970
Ca	Stoneware	white	1		Liaoning Provincial Museum	late	Cat. 971
Ca	Porcelain	white	1			early	Cat. 972

Type	Body	Glaze	Amount	Unearthed From	Collected By	Date (AD)	Cat.No.
Ca	Stoneware	white	1	BL1	Liaoning Provincial Museum	Middle	Cat. 973
Ca	Porcelain	white	1	GZX		1027	Cat. 974
Ca	Stoneware	white	1	GWYC kiln site	Guan Baocong collection	late	Cat. 975
Ca	Pinkish earthenware	yellow	1	BL3		late	Cat. 976
Ca	Pinkish earthenware	white	1		Guan Baocong collection	late	Cat. 977
Ca	Pinkish earthenware	yellow	1		Liaoning Provincial Museum		Cat. 978
Ca	Pinkish earthenware	yellow	1		Guan Baocong collection	late	Cat. 980
Cb	Stoneware	green	1	DQTL3		early	Cat. 981
Cb	Porcelain	white	1	CGGZ	Research institute of cultural relics and archaeology of Inner Mongolia	1018	Cat. 982
Cb	Pinkish earthenware	green	1	YMT22		middle	Cat. 983
D	Pinkish earthenware	yellow	1	DSL1		Middle	Cat. 984
D	Pinkish earthenware	yellow	1	JFYZ	Chifeng Municipal Museum, Inner Mongolia	late	Cat. 985

Type	Body	Glaze	Amount	Unearthed From	Collected By	Date (AD)	Cat.No.
D	Pinkish earthenware	green	1	A tomb at Xinlincun, Xianfeng township, A Luke'erqin Banner, Inner Mongolia		late	Cat. 986
D	Pinkish earthenware	yellow	4	XLZZ1,3,4		late	Cat. 987
D	Pinkish earthenware	white	1	ZDB		early	Cat. 988
D	Pinkish earthenware	yellow	1	BL3		late	Cat. 989
D	Stoneware	white	1	A tomb at Laopogou, Linjiadi Township, Aohan Banner, Inner Mongolia	Aohan Banner Museum, Inner Mongolia	late	Cat. 990
D	Stoneware	white	1		Buffalo Museum of Science, New York	early	Cat. 991
D	Stoneware	white	1		Liaoning Provincial Museum	late	Cat. 992
D	Stoneware	white	1		Aohan Banner Museum, Inner Mongolia	late	Cat. 993
D	Stoneware	white	1			late	Cat. 994
D	Pinkishearthe nware	yellow	1		The Palace Museu, Beijing	late	Cat. 995
D	Pinkishearthe nware	green	1			late	Cat. 996

Type	Body	Glaze	Amount	Unearthed From	Collected By	Date (AD)	Cat.No.
D	Stoneware	white	1		Liaoning Provincial Museum	late	Cat. 997
D	Pinkish earthenware	green	1		Chifeng Municipal Museum, Inner Mongolia	late	Cat. 998
E	Stoneware	green	1	DQTL3		early	Cat. 999
E	Stoneware	white	1	YLYZ		942	Cat. 1000
E	Stoneware	white	1	LBB		early	Cat. 1003
E	Stoneware	brwon	1	YMT?	Liaoning Provincial Museum	?	Cat. 1002

TABLE 43 LIST OF UNEARTHED OBJECTS AND OTHER COLLECTIONS: DRAGON-HANDLED BOWL

Type	Body	Glaze	Amount	Unearthed From	Collected By	Date (AD)	Cat. No.
	Pinkish earthenware	yellow	1	ZWZ		1093	Cat. 1005
	Pinkish earthenware	yellow	1	ZSQ		1116	Cat. 1006
	Pinkish earthenware	yellow	1	ZSB		1089-1144	Cat. 1007
	Pinkish earthenware	yellow	1	JSFJ		late	Cat. 1008

Type	Body	Glaze	Amount	Unearthed From	Collected By	Date (AD)	Cat. No.
	Pinkish earthenware	green	1		Private collection		Cat. 1009
	grass		1	XTM(MWG3)		1070	Cat. 1010

TABLE 44 LIST OF UNEARTHED OBJECTS AND OTHER COLLECTIONS: FLAT-BASE BOWL

Type	Body	Glaze	Amount	Unearthed From	Collected By	Date (AD)	Cat. No.
A	Silver		1		Inner Mongolia autonomous region museum	late	Cat. 1014
A	Porcelain	white	1	HYM		997	Cat. 1015
A	Porcelain	white	1	WDGM		middle	Cat. 1016
A	Porcelain	white	1	WDGM		middle	Cat. 1017
A	Stoneware	green	1	PJG1		middle	Cat. 1018
B	Pinkish earthenware	yellow	1	ZSQ		1116	Cat. 1019
B	Porcelain	white	1	Tomb at Xiyongfeng village, Anci Township, Langfang City, Hebei Province	Relics office of Langfang, Hebei	late	Cat. 1020
B	Pinkish earthenware	green	1			late	Cat. 1021

Type	Body	Glaze	Amount	Unearthed From	Collected By	Date (AD)	Cat. No.
B	Gilt silver		1		Research Institute of Cultural Relics and Archaeology of Inner Mongolia	middle	Cat. 1022

TABLE 45 LIST OF UNEARTHED OBJECTS AND OTHER COLLECTIONS: STEP-FOOT BOWL

Type	Body	Glaze	Amount	Unearthed From	Collected By	Date (AD)	Cat. No.
	stoneware	white	1	SZG1		early	Cat. 1023
	stoneware	white	1	HLB1		early	Cat. 1024
	stoneware	white	1				Cat. 1025
	Pinkish earthenware	green	1	QCH	Liaoning Provincial Museum	Middle	Cat. 1026
	Stoneware	white	1	At Liao old city of Lizhou, Kaozuo county, Liaoning Province			Cat. 1027
	Pinkish earthenware	green	1		Liaoning Provincial Museum	late	Cat. 1028

TABLE 46 LIST OF UNEARTHED OBJECTS AND OTHER COLLECTIONS: RING-FOOT DISH

Type	Body	Glaze	Amount	Unearthed From	Collected By	Date (AD)	Cat. No.
Aa	Porcelain	white	1	GZX		1026	Cat. 1029

Type	Body	Glaze	Amount	Unearthed From	Collected By	Date (AD)	Cat. No.
Aa	Porcelain	white	4	SJG1		1002	Cat. 1030
Aa	Porcelain	white	1	GMZ		late	Cat. 1031
Aa	Pinkish earthenware	white	1	DPC		middle	Cat. 1032
Aa	Stoneware	white	1	GSZ1 (M1:1)		late	Cat. 1033
Aa	Stoneware	white	1	GSZ2 (M2:3)		late	Cat. 1034
Aa	Pinkish earthenware	Three-colored	1	XLZZ1		late	Cat. 1035
Aa	Pinkish earthenware	Three-colored	1	XLZZ1		late	Cat. 1036
Aa	Pinkish earthenware	Three-colored	1	XLZZ1		late	Cat. 1037
Aa	Stoneware	white	1	LQW kiln site		late	Cat. 1038
Aa	Pinkish earthenware	Three-colored	1	A tomb at Xinlin village, Xianfeng Township, Aluke'erqin Banner, Inner Mongolia		late	Cat. 1039
Aa	Pinkish earthenware	white	1	WLHD		late	Cat. 1040
Aa	Stoneware	white	1	YS3		late	Cat. 1041

Type	Body	Glaze	Amount	Unearthed From	Collected By	Date (AD)	Cat. No.
Aa	Porcelain	white	1	YMT8		late	Cat. 1042
Aa	Stoneware	white	2	PJG3		late	Cat. 1043
Aa	Stoneware	white	4	HQY6		late	Cat. 1044
Aa	Pinkish earthenware	yellow	1		Indianapolis Museum of Art	late	Cat. 1045
Aa	Pinkish earthenware	yellow	1		Guan Baocong collection	late	Cat. 1046
Aa	Pinkish earthenware	yellow	1		The Palace Museum, Beijing	late	Cat. 1047
Aa	Pinkish earthenware	yellow	1			late	Cat. 1048
Aa	Pinkish earthenware	yellow	1		Guan Baocong collection	late	Cat. 1049
Aa	Pinkish earthenware	Three-colored	1		Inner Mongolia autonomous region museum	late	Cat. 1050
Aa	Pinkish earthenware	Three-colored	1		Tokyo National Museum	late	Cat. 1051
Aa	Pinkish earthenware	Three-colored	1			late	Cat. 1052

Type	Body	Glaze	Amount	Unearthed From	Collected By	Date (AD)	Cat. No.
Aa	Pinkish earthenware	Three-colored	1			late	Cat. 1053
Aa	Pinkish earthenware	Three-colored	1	A tomb at Shuangsheng Village, Longchang Township, Balin Left Banner, Inner Mongolia	Liaoshangjing Museum, Inner Mongolia	late	Cat. 1054
Aa	Pinkish earthenware	Three-colored	1			late	Cat. 1055
Aa	Pinkish earthenware	Three-colored	1		Guan Baocong collection	late	Cat. 1056
Aa	Pinkish earthenware	Three-colored	1		Guan Baocong collection	late	Cat. 1057
Aa	Pinkish earthenware	Three-colored	1		Liaoning Tieling qunzhongyishuguan wenwuzu	late	Cat. 1058
Aa	Pinkish earthenware	Three-colored	1		Liaoning Provincial Museum	late	Cat. 1059
Aa	Pinkish earthenware	yellow	1		Liaoning Tieling qunzhongyishuguan wenwuzu	late	Cat. 1060
Aa	Pinkish earthenware	white	1		Liaoning Tieling qunzhongyishuguan wenwuzu	late	Cat. 1061

Type	Body	Glaze	Amount	Unearthed From	Collected By	Date (AD)	Cat. No.
Aa	Pinkish earthenware	Three-colored	1	At Dongzhan commune of Qianguo county, Jilin Province	Jilin Provincial Museum	late	Cat. 1062
Aa	Pinkish earthenware	green	1		Chifeng Municipal Museum	late	Cat. 1063
Aa	Pinkish earthenware	Three-colored	1		Jilin Provincial Museum	late	Cat. 1064
Aa	Pinkish earthenware	Three-colored	1		Liaoning Provincial Museum	late	Cat. 1065
Aa	Pinkish earthenware	Three-colored	1		Liaoning Provincial Museum	late	Cat. 1066
Aa	Porcelain	white	1	Tomb at Xiyongfeng village, Anci Township, Langfang city, Hebei province	Relics office of Langfang, Hebei Province	late	Cat. 1067
Aa	Pinkish earthenware	Three-colored	1		Liaoning Provincial Museum	late	Cat. 1068
Ab	Porcelain	white	1	DQTL3		early	Cat. 1069
Ab	Porcelain	white	1	Tomb of Xiaohe at Fuxin, Liaoning Province (M4: 26)		997-1021	Cat. 1070

Type	Body	Glaze	Amount	Unearthed From	Collected By	Date (AD)	Cat. No.
Ab	Porcelain	white	1	Tomb of Xiaohe at Fuxin, Liaoning Province (M4: 27)		997-1021	Cat. 1071
Ab	Porcelain	white	4	Tomb of Xiaohe at Fuxin, Liaoning Province (M4: 32)		997-1021	Cat. 1072
Ab	Porcelain	white	4	Tomb of Xiaohe at Fuxin, Liaoning Province (M4: 36)		997-1021	Cat. 1073
Ab	Porcelain	white	1	Pagoda JGS		1013	Cat. 1074
Ab	Porcelain	white	1	DXG1		997-1021	Cat. 1075
Ab	Porcelain	white	1	DXG1		997-1021	Cat. 1076
Ab	Porcelain	white	4	Pagoda QZBT		1049	Cat. 1077
Ab	Porcelain	white	1	DXG1		997-1021	Cat. 1078
Ab	Porcelain	white	1	DXG1		997-1021	Cat. 1079
Ab	Porcelain	white	1	DXG1		997-1021	Cat. 1080
Ab	Porcelain	white	2	ZWZ		1093	Cat. 1081
Ab	Porcelain	white	4	ZWZ		1093	Cat. 1082

Type	Body	Glaze	Amount	Unearthed From	Collected By	Date (AD)	Cat. No.
Ab	Porcelain	White 青 白	1	Tomb at Nanjianta, Anci district, Langfang city, Hebei Province	Relics office of Langfang, Hebei Province	late	Cat. 1083
Ab	Porcelain	white	3	PJG3		late	Cat. 1084
Ab	Porcelain	white	1		Guan Baocong collection	late	Cat. 1085
Ab	Porcelain	white	1	BTYZ	Liaoning Provincial Museum	late	Cat. 1086
Ab	Porcelain	white	1		Guan Baocong collection	late	Cat. 1087
Ba	Porcelain	white	6	SZG1		early	Cat. 1088
Ba	Porcelain	white	1	BTZ		1081	Cat. 1089
Ba	Porcelain	white	2	PJG3		Late	Cat. 1090
Ba	Porcelain	white	1		Guan Baocong collection		Cat. 1091
Ba	Stoneware	white	1	A tomb at Chaduba, Chaoyang, Liaoning	Chapyang Municipal Museum, Liaoning	late	Cat. 1092
Ba	Stoneware	white	3	A tomb at Chenggou, Fuxin, Liaoning	Fuxin Municipal Museum, Liaoning	late	Cat. 1093

Type	Body	Glaze	Amount	Unearthed From	Collected By	Date (AD)	Cat. No.
Ba	Stoneware	white	6	TJYZ	Chifeng Municipal Museum, Inner Mongolia	late	Cat. 1094
Ba	Stoneware	white	1	WFG		late	Cat. 1095
Ba	Stoneware	white	1	Tomb at Xiyongfeng village, Anci district, Langfang city, Hebei Province		late	Cat. 1096
Ba	Stoneware	white	4	HQY9		late	Cat. 1097
Ba	Stoneware	white	2	TJYZ		late	Cat. 1098
Ba	Porcelain	white	1	WFG		late	Cat. 1099
Bb	Porcelain	white	1	DQTL3		early	Cat. 1100
Bb	Porcelain	white	1	HLB1		early	Cat. 1101
Bb	Porcelain	white	1	TZM2 (M2:5)		middle	Cat. 1102
Bb	Stoneware	white	2	ZJY1	Tieling Municipal Museum, Liaoning	early	Cat. 1103
Bb	Porcelain	white	1	YMT7	Liaoning Provincial Museum	977	Cat. 1104

Type	Body	Glaze	Amount	Unearthed From	Collected By	Date (AD)	Cat. No.
Bb	Silver		1		Research Institute of Cultural Relics and Archaeology of Inner Mongolia	early	Cat. 1106
Bb	Porcelain	white	1	MJ1		late	Cat. 1107
Bb	Porcelain	white	2	ZWZ		1093	Cat. 1108
Bb	Porcelain	white	1	CDMM		late	Cat. 1109

TABLE 47 LIST OF UNEARTHED OBJECTS AND OTHER COLLECTIONS: FLAT-BASE DISH

Type	Body	Glaze	Amount	Unearthed From	Collected By	Date (AD)	Cat. No.
A	Pinkish earthenware	Three-colored	1	FZZ		late	Cat. 1110
A	Pinkish earthenware	Three-colored	8	BL3		late	Cat. 1111
A	Pinkish earthenware	Three-colored	1		Liaoning Provincial Museum	late	Cat. 1112
A	Pinkish earthenware	Three-colored	1	A tomb at Zhangjiayingzi, Jianping County, Liaoning Province	Liaoning Provincial Museum	late	Cat. 1113
A	Pinkish earthenware	Three-colored	1			late	Cat. 1114

Type	Body	Glaze	Amount	Unearthed From	Collected By	Date (AD)	Cat. No.
A	Pinkish earthenware	Three-colored	1			late	Cat. 1115
A	Pinkish earthenware	Three-colored	1	GWYC kiln site	Guan Baocong collection	late	Cat. 1116
A	Pinkish earthenware	Three-colored	1			late	Cat. 1117
A	Pinkish earthenware	Three-colored	1	A tomb at Wulanba village, Haoertu township, Balin Left banner, Inner Mongolia	Liaoshangjing Museum, Inner Mongolia	late	Cat. 1118
A	Pinkish earthenware	Three-colored	1			late	Cat. 1119
A	Pinkish earthenware	Three-colored	1		Center of Asian Art and Culture, Avery Brundage Collection, San Francisco, California	late	Cat. 1120
A	Pinkish earthenware	Three-colored	1		Liaoning Provincial Museum	late	Cat. 1121
A	Pinkish earthenware	Three-colored	1		The Palace Museum, Beijing	late	Cat. 1122
A	Pinkish earthenware	Three-colored	1		Private collection, Singapore	late	Cat. 1123
A	Porcelain	white	1	Pagoda Qiyinsi at Xianghe county, Hebei province		1006	Cat. 1124
A	Porcelain	white	4	WJS1	Chifeng Municipal Museum	late	Cat. 1125

Type	Body	Glaze	Amount	Unearthed From	Collected By	Date (AD)	Cat. No.
A	Porcelain	white	3	Tomb at Xiyongfeng village, Anci county, Langfang city, Hebei province	Relics office of Langfang, Hebei province		Cat. 1126
A	Porcelain	white	4	YS3			Cat. 1127
A	Porcelain	white	1	ZWZ		1093	Cat. 1128
A	Porcelain	white	2	GS1		late	Cat. 1129
A	Porcelain	green	1	DPC		middle	Cat. 1130
A	Porcelain	white	10	ZGY		1117	Cat. 1131
B	Porcelain	white	10	Pagoda BZCT		1051	Cat. 1132
B	Porcelain	white	5	Pagoda CYBTTG		1043	Cat. 1133
B	Porcelain	white	1	Pagoda CYBTTG		1043	Cat. 1134
B	Porcelain	white	1	Pagoda CYBTTG		1043	Cat. 1135

Type	Body	Glaze	Amount	Unearthed From	Collected By	Date (AD)	Cat. No.
B	Porcelain	white	2	QHM2		1057	Cat. 1136
B	Porcelain	white	1		The Capital Museum, Beijing		Cat. 1137
B	Porcelain	white	1		Museum of Far Eastern Antiquities: Kempe Collection, Stockholm(392)		Cat. 1138
B	Porcelain	white	2	A tomb at Hadatu Village, Hadayingge Township, Balin Left Banner, Inner Mongolia	Liaoshangjing Museum, Inner Monglia		Cat. 1139
B	Porcelain	white	1		Art Institute of Chicago: Lucy Maud Buckingham Collection		Cat. 1140
B	Porcelain	white	1		The Cleveland Museum of Art, John L. Serverance Fundation		Cat. 1141
B	Porcelain	white	1		Buffalo Museum of Science		Cat. 1142
B	Earthenware biscuit mould instrument	unglazed	1	LQW kiln site		late	Cat. 1143
B	Pinkish earthenware	green	1	LQW kiln site		late	Cat. 1144
B	Pinkish earthenware	green	1	LQW kiln site		late	Cat. 1145
B	Pinkish earthenware	Three-col ored	3	XXZ		1089	Cat. 1146

Type	Body	Glaze	Amount	Unearthed From	Collected By	Date (AD)	Cat. No.
B	Pinkish earthenware	Three-colored	2	XPJG		late	Cat. 1147
B	Pinkish earthenware	Three-colored	3	XLZZ1		late	Cat. 1148
B	Pinkish earthenware	Three-colored	1			late	Cat. 1149
B	Pinkish earthenware	Three-colored	1			late	Cat. 1150
B	Pinkish earthenware	Three-colored	1		The Palace Museum, Beijing	late	Cat. 1151
B	Pinkish earthenware	Three-colored	1		Mr. Victor Hauge, Falls Church, Virginia	late	Cat. 1152
B	Pinkish earthenware	Three-colored	1		Liaoning Provincial Museum	late	Cat. 1153
B	Pinkish earthenware	Three-colored	1		Liaoning Provincial Museum	late	Cat. 1154
B	Pinkish earthenware	Three-colored	1		Chifeng Municipal Museum	late	Cat. 1155
B	Pinkish earthenware	Three-colored	1		Chifeng Municipal Museum	late	Cat. 1156
B	Pinkish earthenware	Three-colored	1		Liaoning Provincial Museum	late	Cat. 1157
C	Porcelain	white	1		Museum of Far Eastern Antiquities: Carl Kempe Collection, Stockholm	early	Cat. 1159

Type	Body	Glaze	Amount	Unearthed From	Collected By	Date (AD)	Cat. No.
D	Pinkish earthenware	Three-colored	1		Liaoning Provincial Museum	late	Cat. 1162
D	Pinkish earthenware	Three-colored	1		Private collection, Singapore	late	Cat. 1163

TABLE 48 LIST OF UNEARTHED OBJECTS AND OTHER COLLECTIONS: OBLONG-LOBED DISH

Body	Glaze	Amount	Unearthed From	Collected By	Date (AD)	Cat. No.
Pinkish earthenware	Three-colored	2	XLZZ1	Research institute of cultural relics and archaeology of Inner Mongolia	late	Cat. 1174
Pinkish earthenware	Three-colored	1	BL3		late	Cat. 1175
Pinkish earthenware	Three-colored	1	PJG3		late	Cat. 1176
Pinkish earthenware	Three-colored	1	BTYZ	Liaoning Provincial Museum	late	Cat. 1177
Pinkish earthenware	Three-colored	1		Tokyo National Museum	late	Cat. 1178
Pinkish earthenware	Three-colored	1		Ataka collection, Osaka	late	Cat. 1179
Pinkish earthenware	Three-colored	1		Liaoning Provincial Museum	late	Cat. 1180
Pinkish earthenware	Three-colored	1		Tokyo National Museum	late	Cat. 1181

Body	Glaze	Amount	Unearthed From	Collected By	Date (AD)	Cat. No.
Pinkish earthenware	Three-colored	1			late	Cat. 1182
Pinkish earthenware	Three-colored	1	XXZ	Liaoning provincial museum	1089	Cat. 1183
Pinkish earthenware	Three-colored	1	XLZZ4		late	Cat. 1184
Pinkish earthenware	Three-colored	1		The Museum Yanato Bunkakan, Nara 大和文华馆	late	Cat. 1185
Pinkish earthenware	Three-colored	1	YS1		late	Cat. 1186
Pinkish earthenware	Three-colored	1		Chifeng Municipal Museum	late	Cat. 1187
Pinkish earthenware	Three-colored	1		Chifeng Municipal Museum	late	Cat. 1188
Pinkish earthenware	Three-colored	1		Liaoning provincial museum	late	Cat. 1189
Pinkish earthenware	Three-colored	1	GWYC kiln site 95HGF1		late	Cat. 1190
Pinkish earthenware	Three-colored	2	YS3		late	Cat. 1191
Pinkish earthenware	Three-colored	1		Guan Baocong collection	late	Cat. 1192
Pinkish earthenware	Three-colored	1			late	Cat. 1193

Body	Glaze	Amount	Unearthed From	Collected By	Date (AD)	Cat. No.
Pinkish earthenware	Three-colored	1		出光美术馆	late	Cat. 1194
Pinkish earthenware	Three-colored	1			late	Cat. 1195
Pinkish earthenware	Three-colored	1		The Palace Museum, Beijing	late	Cat. 1196
Pinkish earthenware	Three-colored	1	A tomb at Xigou, Manihan Township, Aohan Banner, Inner Mongolia	Aohan Banner Museum, Inner Mongolia	late	Cat. 1197
Pinkish earthenware	Three-colored	1			late	Cat. 1198
Pinkish earthenware	Three-colored	1		Liaoning Tieling qunzhongyishuguan wenwuzu	late	Cat. 1199
Pinkish earthenware	Three-colored	1		Liaoning Provincial Museum	late	Cat. 1200
Pinkish earthenware	Three-colored	1		Liaoning Provincial Museum	late	Cat. 1201

TABLE 49 LIST OF UNEARTHED OBJECTS AND OTHER COLLECTIONS: INKSTONE AND BRUSH-WASHER

Type	Body	Glaze	Amount	Unearthed From	Collected By	Date (AD)	Cat. No.
A	stoneware	white	1	DYZ3		middle	Cat. 1202

Type	Body	Glaze	Amount	Unearthed From	Collected By	Date (AD)	Cat. No.
A	Pinkish earthenware	Three-colored	1	BTYZ	Liaoning Provincial Museum	late	Cat. 1203
A	Pinkish earthenware	Three-colored	1	SFC	Inner Mongolia autonomous region museum	1066	Cat. 1204
A	Pinkish earthenware	Three-colored	1			late	Cat. 1205
A	Pinkish earthenware	Three-colored	1		Museum für Ostasiatische Kunst, Staatliche Museen Preussischer Kuterbesitz, Berlin	late	Cat. 1206
A	Pinkish earthenware	Three-colored	1		Tokyo National Museum	late	Cat. 1207
A	Pinkish earthenware	Three-colored	1		Private collection , Singapore	late	Cat. 1208
A	Pinkish earthenware	Three-colored	1		Private collection	late	Cat. 1209
A	Pinkish earthenware	Three-colored	1	A tomb at Shifo Township, Ningcheng County, Inner Mongolia	Ningcheng Museum, Inner Mongolia	late	Cat. 1210
A	Pinkish earthenware biscuit		1	GWYC kiln site	Research institute of culatural relics and archaeology of Inner Mongolia	late	Cat. 1211
A	Pinkish earthenware	Three-colored	1		Chifeng municipal museum, Inner Mongolia	late	Cat. 1212

Type	Body	Glaze	Amount	Unearthed From	Collected By	Date (AD)	Cat. No.
B	Pinkish earthenware	Three-colored	1	XLZZ3	Inner Mongolia autonomous region museum	late	Cat. 1213
B	Pinkish earthenware	Three-colored	1	XTM(MWG3)	Research institute of cultural relics and archaeology of Inner Mongolia	1070	Cat. 1214
B	Pinkish earthenware	Three-colored	1		Private collection	late	Cat. 1215
B	Pinkish earthenware	Three-colored	1		Private collection	late	Cat. 1216
B	Pinkish earthenware	Three-colored	1		Matsuoka Art Museum, Tokyo		Cat. 1217
C	Pinkish earthenware	yellow	1	BTYZ		late	Cat. 1218

TABLE 50 LIST OF UNEARTHED OBJECTS AND OTHER COLLECTIONS: OCARINA

Type	Body	Glaze	Amount	Unearthed From	Collected By	Date (AD)	Cat. No.
A	Pinkish earthenware	Three-colored	1		The Palace Museum, Beijing	late	Cat. 1219
A	Pinkish earthenware	Three-colored	1		Chifeng Municipal Museum	late	Cat. 1220
A	Pinkish earthenware	Three-colored	1	XTM(MWG3)	Research institute of cultural relics and archaeology of Inner Mongolia	1071	Cat. 1221
A	Pinkish earthenware	yellow	1	A tomb at Yaojiagou, Jinchanggouliang Township, Aohan Banner, Inner Mongolia	Aohan Banner Museum, Inner Mongolia	late	Cat. 1222

Type	Body	Glaze	Amount	Unearthed From	Collected By	Date (AD)	Cat. No.
A	Pinkish earthenware	Three-colored	1	A tomb at Songshan district, Chifeng city, Inner Mongolia	Chifeng Municipal Museum, Inner Mongolia	late	Cat. 1223
A	Pinkish earthenware	Three-colored	1	XLZZ4		late	Cat. 1224
A	Pinkish earthenware		1	A tomb at Yuanbao district, Chifeng city, Inner Mongolia	Chifeng Municipal Museum, Inner Mongolia	late	Cat. 1225
A	Pinkish earthenware		1		Chifeng Municipal Museum, Inner Mongolia	late	7-2
A	Pinkish earthenware biscuit		1	GWYC kiln site	Guan Baocong collection	late	Cat. 1226
A	Pinkish earthenware	green	1	A tomb at Linchang, Longchang Township, Balin Left Banner, Inner Mongolia	LiaoShangjing museum, Inner Mongolia	late	Cat. 1227
A	Pinkish earthenware	Three-colored	1		Private collection, Sincapore	late	Cat. 1228
A	Pinkish earthenware	Three-colored	1		Private collection	late	Cat. 1229
A	Pinkish earthenware	Three-colored	1		Private collection	late	Cat. 1230
A	Pinkish earthenware	Three-colored	1	A tomb at Sidetang Township, Aohan Banner, Inner Mongolia	Aohan Banner Museum	late	Cat. 1231
B	stoneware	white	1	GWYC kiln site	Guan Baocong collection	late	Cat. 1232

Type	Body	Glaze	Amount	Unearthed From	Collected By	Date (AD)	Cat. No.
B	stoneware	brown	1	The Hancheng site of Shangjing, Balin Left Banner, Inner Mongolia	Liaoshangjing Museum, Inner Mongolia	late	Cat. 1233
B	stoneware	white	1	GWYC kiln site	Liaoning provincial museum	late	Cat. 1234
B	stoneware	white	1	LQW kiln site		late	Cat. 1235
B	stoneware	brown	1	GGT kiln site	Guan Baocong collection	late	Cat. 1236
B	stoneware	white	1	GWYC kiln site	Lianing provincial museum	late	Cat. 1237
B	stoneware	brown	1	GGT kiln site	Guan Baocong collection	late	Cat. 1238
B	stoneware	white	1	GGT kiln site	Guan Baocong collection	late	Cat. 1239
B	stoneware	white	1	GWYC kiln site	Guan Baocong collection	late	Cat. 1240
B	stoneware	brown	1	GGT kiln site	Guan Baocong collection	late	Cat. 1241
C	Pinkish earthenware	Three-colored	1	HPYZ1	Relics office of Songshan district, Chifeng city, Inner Mongolia	late	Cat. 1242
C	Pinkish earthenware	Three-colored	1		Liaoning Provincial Museum	late	Cat. 1243
C	Pinkish earthenware	White	1		Liaoning Provincial Museum	late	Cat. 1244

TABLE 51 LIST OF UNEARTHED OBJECTS AND OTHER COLLECTIONS: PILLOW

Type	Body	Glaze	Amount	Unearthed From	Collected By	Date (AD)	Cat. No.
A	Pinkish earthenware	yellow	1	ELC		middle	Cat. 1245
A	Stoneware	white	1	HLC1		Early?	Cat. 1246
A	Stoneware	green	1	A tomb at Wulan village, Xinhui Township, Aohan Banner, Inner Mongolia	Chifeng Municipal Museum		Cat. 1247
A	Pinkish earthenware	green	1	Dahuangye kiln site, Gongyi, Hebei province		1159	Cat. 1248
A	Stoneware	white	1	A tomb at Banbu village, Baiyinaobao Township, Balin Left Banner, Inner Mongolia	Liaoshangjing museum, Inner Mongolia		Cat. 1249
A	Pinkish earthenware	green	1	HTH1	Research institute of cultural relics and archaeology of Inner Mongolia	middle	Cat. 1250
A	stoneware	?	1	LQW kiln site			Cat. 1251
A	stoneware	white	1		Aohan Banner Museum, Inner Mongolia		Cat. 1252
B	Porcelaneous stoneware	white	1	A tomb at Buhetehada, Bayanerdeng sumu, Balin ringht Banner, Inner Mongolia	Baolin Right Banner Museum, Inner Mongolia		Cat. 1253
B	Stoneware	white	1				Cat. 1254

Type	Body	Glaze	Amount	Unearthed From	Collected By	Date (AD)	Cat. No.
B	Stoneware	white	1	A tomb at Guojia village, Xidayingzi Township, Chaoyang city, Liaoning Province	Liaoning Provincial Museum	late	Cat. 1255
C	stoneware	whtie	1		Aohan Banner Museum, Inner Mongolia		Cat. 1256
C	stoneware	black	1		Guan Baocong collection		Cat. 1257
D	Pinkish earthenware biscuit		1	LQW kiln site			Cat. 1258

TABLE 52 LIST OF UNEARTHED OBJECTS AND OTHER COLLECTIONS: BOX

Type	Body	Glaze	Amount	Unearthed From	Collected By	Date (AD)	Cat. No.
A	porcelain	white	1	HLB1		early	Cat. 1259
A	porcelain	white	1	BS1		923	Cat. 1260
A	porcelain	white	1	TZM2:4		middle	Cat. 1261
A	porcelain	white	1	CGGZ	Research institute of cultural relics and archaeology of Inner Mongolia	1018	Cat. 1262
A	porcelain	white	1	Pagoda JGS		1013	Cat. 1263

Type	Body	Glaze	Amount	Unearthed From	Collected By	Date (AD)	Cat. No.
A	porcelain	white	1	WZM		1053	Cat. 1264
A	porcelain	white	1	YMT2		late	Cat. 1265
A	porcelain	white	1	Tomb at Yaojiagou, Jinchanggouliang Township, Aohan Banner, Inner Mongolia	Aohan Banner Museum		Cat. 1266
A	porcelain	white	1		Guan Baocong collection		Cat. 1267
A	porcelain	white	1		Guan Baocong collection		Cat. 1268
A	porcelain	white	1		Royal Ontario Museum, Toronto		Cat. 1269
A	stoneware	white	1	KL5		late	Cat. 1270
A	stoneware	white	1			late	Cat. 1271
A	stoneware	white	1	GGT kiln site	Guan Baocong collection	late	Cat. 1272
Ba	Pinkish earthenware	yellow	5 in set	JFYZ	Chifeng municipal museum	late	Cat. 1273
Ba	Pinkish earthenware	Three-col ored	2 in set		Guan Baocong collection	late	Cat. 1274
Ba	Pinkish earthenware	Three-col ored	1			late	Cat. 1275

Type	Body	Glaze	Amount	Unearthed From	Collected By	Date (AD)	Cat. No.
Ba	Pinkish earthenware	Three-colored	1		Chifeng municipal museum	late	Cat. 1276
Bb	Pinkish earthenware	Three-colored	2 in set	JFYZ	Inner Mongolia autonomous region museum	late	Cat. 1277
Bb	Pinkish earthenware	Three-colored	1		Guan Baocong collection	late	Cat. 1278
Bc	Pinkish earthenware	yellow	5 in set	A tomb at Baitazi commune, Kazuo County, Liaoning province	Kazuo Museum, Liaoning Province	late	Cat. 1279

TABLE 53 LIST OF UNEARTHED OBJECTS AND OTHER COLLECTIONS: LAMP AND INCENSE BURNER

Type	Body	Glaze	Amount	Unearthed From	Collected By	Date (AD)	Cat. No.
A	Porcelain	white	1	WZM		1053	Cat. 1280
A	Porcelain	brown	1	LQW kiln site		Late	Cat. 1281
A	Stoneware	white	1		Guan Baocong collection	late	Cat. 1282
A	Pinkish earthenware	yellow	1		Private collection	late	Cat. 1283
Ba	Porcelain	white	1	LQW kiln site			Cat. 1284
Bb	Porcelain	white	1	LQW kiln site			Cat. 1285
C	stoneware	black	1	GGT kiln site	Guan Baocong collection	late	Cat. 1286
C	stoneware	black	1	GGT kiln site	Guan Baocong collection	late	Cat. 1287
C	stoneware	black	1	GGT kiln site	Guan Baocong collection	late	Cat. 1288
C	stoneware	black	1	GGT kiln site	Guan Baocong collection	late	Cat. 1289

TABLE 54 LIST OF UNEARTHED OBJECTS AND OTHER COLLECTIONS: SCULPTURE

Body	Glaze	Amount	Unearthed From	Collected By	Date (AD)	Cat. No.
Stoneware	white	1		Guan Baocong collection	Late	Cat. 1290
Pinkish earthenware	green	1	Hancheng site of Liaoshangjing site, Balin Left Banner, Inner Mongolia	Liaoshangjing Museum, Inner Mongolia	Late	Cat. 1291
Stoneware	white	1	Hancheng site of Liaoshangjing site, Balin Left Banner, Inner Mongolia	Liaoshangjing Museum, Inner Mongolia	Late	Cat. 1292
Stoneware	White	1	Hancheng site of Liaoshangjing site, Balin Left Banner, Inner Mongolia	Liaoshangjing Museum, Inner Mongolia	Late	Cat. 1293
Stoneware	Tee-dust green	1	HDYG kiln site	Guan Baocong collection	Late	Cat. 1294
Stoneware	white	1	Lamagou village, Saliba Township, Aohan Banner, Inner Mongolia	Aohan Banner Museum, Inner Mongolia	Late	Cat. 1295
Stoneware	white	1		Aohan Banner Museum, Inner Mongolia	Late	Cat. 1296
Stoneware	brown	1	GGT kiln site	Guan Baocong collection	Late	Cat. 1297
Porcelain	white	1		Guan Baocong collection	Late	Cat. 1298
Stoneware	white	1		Guan Baocong collection	Late	Cat. 1299
Stoneware	brown	1	GGT kiln site	Guan Baocong collection	Late	Cat. 1300

Body	Glaze	Amount	Unearthed From	Collected By	Date (AD)	Cat. No.
Stoneware	Green and yellow	1	GWYC kiln site	Guan Baocong collection	Late	Cat. 1301
Stoneware	white	1	GGT kiln site	Guan Baocong collection	Late	Cat. 1302
Stoneware	black	1	GGT kiln site	Guan Baocong collection	Late	Cat. 1303
Stoneware	black	1	GGT kiln site	Guan Baocong collection	Late	Cat. 1304
Stoneware	white	1	GWYC kiln site	Guan Baocong collection	Late	Cat. 1305
Stoneware	brown	1	GGT kiln site	Guan Baocong collection	Late	Cat. 1306
Stoneware	white	1	GWYC kiln site	Guan Baocong collection	Late	Cat. 1307
Stoneware	white	1	GWYC kiln site	Guan Baocong collection	Late	Cat. 1308
Stoneware	white	1	GWYC kiln site	Guan Baocong collection	Late	Cat. 1309
Stoneware	white	1	GWYC kiln site	Guan Baocong collection	Late	Cat. 1310
Stoneware	white	1	GGT kiln site	Guan Baocong collection	Late	Cat. 1311
Stoneware	white	1	GWYC kiln site	Guan Baocong collection	Late	Cat. 1312
Stoneware	white	1	GWYC kiln site	Guan Baocong collection	Late	Cat. 1313
Stoneware	white	1	GWYC kiln site	Guan Baocong collection	Late	Cat. 1314
Stoneware	white	1		Guan Baocong collection	Late	Cat. 1315
Stoneware	white	1	Hancheng site of Liaoshangjing site, Balin Left Banner, Inner Mongolia	Liaoshangjing Museum, Inner Mongolia	Late	Cat. 1316
Stoneware	white	1	Hancheng site of Liaoshangjing site, Balin Left Banner, Inner Mongolia	Liaoshangjing Museum, Inner Mongolia	Late	Cat. 1317

Body	Glaze	Amount	Unearthed From	Collected By	Date (AD)	Cat. No.
Stoneware	white	1	Hancheng site of Liaoshangjing site, Balin Left Banner, Inner Mongolia	Liaoshangjing Museum, Inner Mongolia	Late	Cat. 1318
Stoneware	white	1	Hancheng site of Liaoshangjing site, Balin Left Banner, Inner Mongolia	Liaoshangjing Museum, Inner Mongolia	Late	Cat. 1319
Porcelain	white	1		Guan Baocong collection	Late	Cat. 1320
Stoneware	blackk	1	GGT kiln site	Guan Baocong collection	Late	Cat. 1321
Pinkish earthenware	Three-colored	1			Late	Cat. 1322
Pinkish earthenware	Three-colored	18 in set		Capital Museum, Beijing	Late	Cat. 1323
Pinkish earthenware	Three-colored	2		Capital Museum, Beijing	Late	Cat. 1324
Pinkish earthenware	Three-colored	1		Capital Museum, Beijing	Late	Cat. 1325
Pinkish earthenware	Three-colored	1		Capital Museum, Beijing	Late	Cat. 1326
Pinkish earthenware	Three-colored	2		Capital Museum, Beijing	Late	Cat. 1327
Pinkish earthenware	Three-colored	1		Capital Museum, Beijing	Late	Cat. 1328

Body	Glaze	Amount	Unearthed From	Collected By	Date (AD)	Cat. No.
Pinkish earthenware	Three-colored	2		Capital Museum, Beijing	Late	Cat. 1329
Pinkish earthenware	Three-colored	1		Capital Museum, Beijing	Late	Cat. 1330
Pinkish earthenware	Three-colored	1		Capital Museum, Beijing	Late	Cat. 1331
Pinkish earthenware	Three-colored	1		Capital Museum, Beijing	Late	Cat. 1332
Pinkish earthenware	Three-colored	1		Capital Museum, Beijing	Late	Cat. 1333
Pinkish earthenware	Three-colored	2		Capital Museum, Beijing	Late	Cat. 1334
Pinkish earthenware	Three-colored	1		Liaoning Provincial Museum	Late	Cat. 1335
Porcelain	white	1	The foundation of Pagoda Qiyinsi, Xianghe, Hebei province		1006	Cat. 1336
Porcelain	White	1	Qianwulibuge village, Nailingaosumu, Kulun Banner, Inner Mongolia	Tongliao Municipal Museum, Inner Mongolia		Cat. 1337
Porcelain	White	1	Qianwulibuge village, Nailingaosumu, Kulun Banner, Inner Mongolia	Tongliao Municipal Museum, Inner Mongolia		Cat. 1338
Pinkish earthenware	Three-colored	1	Yizhou, Hebei province		Late	Cat. 1339

Body	Glaze	Amount	Unearthed From	Collected By	Date (AD)	Cat. No.
Pinkish earthenware	Three-colored	1	Yizhou, Hebei Province		Late	Cat. 1340
Pinkish earthenware	Three-colored	1		Kansas Museum	Late	Cat. 1341
Pinkish earthen ware biscuit		1	LQW kiln site		Late	Cat. 1342
Pinkish earthenware	Three-colored	1	LQW kiln site	Capital Museum, Beijing	Late	Cat. 1343
Stoneware	black	1	GGT kiln site	Guan Baocong collection	Late	Cat. 1344
Stoneware	white	1	GGT kiln site	Guan Baocong collection	Late	54-2
Pinkish earthenware	Three-colored	1		Guan Baocong collection	Late	Cat. 1345

BIBLIOGRAPHY

- Addis, J. M. 1978. *Chinese Ceramics from Datable Tombs and Some Other Dated Materials : A Handbook*. London ; New York: Sotheby Parke Bernet.
- Aluke'erqin qi wenguansuo et al. 阿鲁科尔沁旗文管所 1996. Aluke'erqin Qi Xianfeng Xiang He Shuangsheng Zhen Liao Mu Qingli Jianbao 阿鲁科尔沁旗先锋乡和双胜镇辽墓清理报告 [Excavation Report of the Liao Tomb at Xianfeng and Shuangsheng Townships in Aluke'erqin Banner]. *Neimenggu wenwu kaogu 内蒙古文物考古* (Z1):78-81.
- Amitai, Reuven, and Michal Biran 2005. *Mongols, Turks, and Others : Eurasian Nomads and the Sedentary World, Brill's Inner Asian Library*,. Leiden ; Boston: Brill.
- An Jiayao 安家瑶 1993. Chenguo Gongzhu Yu Fuma Hezang Mu Chtu De Bolli Qimi Ji Youguan Wenti 陈国公主与驸马合葬墓出土的玻璃器皿及有关问题 [Glassware from Princess Chen's Tomb and Discussion on the Related Problems]. In *Liao Chenguo Gongzhu Mu 辽陈国公主墓 [Tomb of the Princess of Chen State]*, edited by Neimenggu zizhi qu wenwu kaogu yanjiusuo. Beijing: Wenwu chubanshe.
- Ang, Melvin Thlick-Len 1983. *Sung-Liao Diplomacy in Eleventh and Twelfth-Century China : A Study of the Social and Political Determinants of Foreign Policy*. Thesis (Ph D), University of Pennsylvania, 1983.
- Anon. 1988. *Glass*. London: Borax Consolidated Limited.
- 1999. Aohanqi Qijia Liao Mu 敖汉旗七家辽墓 [Liao Tomb at Qijia in Aohan Banner]. *Neimenggu wenwu kaogu 内蒙古文物考古* (1):46-66,104.
- Anshanshi wenhuaju 鞍山市文化局 1981. Liaoning Anshanshi Wangjiayu Liaodai Huaxiangshi Mu 辽宁鞍山市汪家峪辽代画像石墓 [Liao Tombs with Stone Carvings at Wangjiayu, Anshan, Liaoning]. *Kaogu 考古* (3):239-242.
- Aohanqi wenhuaguan 敖汉旗文化馆 1978. Aohanqi Lijiayinzi Chutu De Jinyinqi 敖汉旗李家营子出土的金银器 [the Gold and Silver Wares Excavated at Lijiayingzi, Aohanqi]. *kaogu 考古* (2):117-118.
- Ba Youwen & Cheng Shun 巴右文 & 成顺 1980. Neimenggu Zhaowudameng Balinyouqi Faxian Liaodai Yinqi Jiaocang 内蒙古昭乌达盟巴林右旗发现辽代银器窖藏 [a Cache of Liao Silver Wares Has Been Discovered at Balinyouqi , Zhaowudameng, Inner Mongolia]. *Wenwu 文物* (5): 45-51.
- Bai Junpo 白俊波 1984. Neimenggu Ningcheng Chutu Liaodai Sancai Hu 内蒙古宁城出土辽代三彩壶 [a Liao Three-Colored Ewer Has Been Unearthed at Ningcheng, Inner Mongolia]. *Wenwu 文物* (3):91.

- Beijing daxue kaogu xi et al. 北京大学考古系等 1997. *Guantai Cizhou Yao Zhi 观台磁州窑 [Cizhou Kiln Site at Guantai]*. Edited by Beijing daxue kaogu xi et al. 北京大学考古系等. Beijing: Wenwu chubanshe.
- Beijing liao jin chengyuan bowuguan 北京辽金城垣博物馆 2003. *20 Shiji Liaojin Shi Xue Lunwen Mulu Suoyin 20 世纪辽金史学论文目录索引 [Index on the Liao and Jin Historical Papers through the 20th Century]*. Edited by Beijing liao jin chengyuan bowuguan. Beijing: Beijing liao jin chengyuan bowuguan.
- 2005. *Beijing Liaojin Wenwu Yanjiu 北京辽金文物研究 [Study on Liao and Jin Relics of Beijing]*. Edited by B. l. c. bowuguan. Beijing: Yanshan chubanshe.
- Beijingshi wenwu gongzuodui 北京市文物工作队 1962. Beijing Nanjiao Liao Zhao Dejun Mu 北京南郊辽赵德钧墓 [the Liao Tomb of Zhao Dejun on the Outskirts South of Beijing]. *Kaogu 考古* (5):246-252.
- 1963. Beijing Xijiao Baiwanzhuang Liaomu Fajue Jianbao 北京西郊百万庄辽墓发掘简报 [a Brief Report of the Excavations of Liao Tombs at Baiwanzhuang on the Outskirts West of Beijing]. *Kaogu 考古* (3):145-146.
- Beijingshi wenwu guanlichu 北京市文物管理处 1972. Jinnianlai Beijing Faxian De Jizuo Liaomu 近年来北京发现的几座辽墓 [the Several Liao Tombs Discovered at Beijing in the Recent Years]. *Kaogu 考古* (3):35-40.
- 1977. Beijing Xiannongtan Liaomu 北京先农坛辽墓 [the Liao Tomb at Xiannongtan, Beijing]. *Wenwu 文物* (11):88-91.
- Beijingshi wenwu shiye guanliju et al. 北京市文物事业管理局 1980. Beijingshi Zhaitang Liaomu Fajue Jianbao 北京市斋堂辽墓发掘简报 [a Brief Report of the Excavations of the Liao Tombs at Zhaitang, Beijing]. *Wenwu 文物* (7):23-27.
- Beijingshi wenwu yanjiusuo 北京市文物研究所 1990. *Beijing Kaogu Sishi Nian 北京考古四十年 [Fourty Years Archaeological Works in Beijing]*. Beijing: Beijing yanshan chubanshe.
- 1992. Beijing Shunyi Anxinzhuang Liao Mu Fajue Jianbao 北京顺义安辛庄辽墓发掘简报 [Excavation Report on the Liao Tomb at Anxinzhuang, Shunyi, Beijing]. *Wenwu 文物* (6):17-23.
- 2002. *Beijing Longquanwu Yao Fa Jue Bao Gao 北京龙泉务窑发掘报告 [Excavations of the Longquanwu Kiln-Site in Beijing]*. Edited by Beijingshi wenwu yanjiusuo 北京市文物研究所. Di 1 ban. ed. Beijing: Wen wu chu ban she.
- 2004. Beijing Daqing Qu Qingyundian Liao Mu 北京大兴区青云店辽墓 [the Liao Tombs at Qingyundian, Daxin, Beijing]. *Kaogu 考古* (2):18-25.
- Ben Heling & Wang Chongcun 贲鹤龄 & 王崇存 2002. Neimenggu Zhaolute Qi Zhe Bei Liaodai Muzang Qun 内蒙古扎鲁特旗哲北辽代墓葬群 [Liao Tombs at Zhebei, Zhaolute Banner, Inner Mongolia]. *Beifang wenwu 北方文物* (04):30-31.

- Ben Heling 賁鹤龄 2002. Kezuo Houqi Baiyin Tala Qidan Muzang 科左后旗白音塔拉契丹墓葬 [Khitan Tombs at Baiyintala, Keyou Rear Banner]. *Neimenggu wenwu kaogu 内蒙古文物考古* (02).
- Bian Chengxiu et al. 边成修等 1958. Shanxi Datongshi Xinanjiao Tang, Liao, Jin Mu Qingli Jianbao 山西大同市西南郊唐辽金墓清理简报 [a Brief Report of the Clearing up of Tang, Liao and Jin Tombs on the Outskirts Southwest of Datong, Shanxi]. *Kaogu tongxun 考古通讯* (6):28-36.
- Bian Chengxiu 边成修 1959. Datong Xinanjiao Faxian Sanzuo Liaodai Bihuamu 大同市西南郊发现三座辽代壁画墓 [Three Liao Tombs with Mural Paintings Have Been Discovered on the Outskirts Southwest of Datong]. *Wenwu 文物* (7):73.
- Biran, Michal 2005. *The Empire of the Qara Khitai in Eurasian History : Between China and the Islamic World, Cambridge Studies in Islamic Civilization*. Cambridge, UK ; New York: Cambridge University Press.
- Bretschneider, E. 1955. *Xi Liao Shi 西辽史 [History of Western Liao]*. Beijing: Zhonghua shuju.
- Cai Yi 蔡毅 1996. Beiju Tese De Liaodai Ciqi 别具特色的辽代瓷器 [Spectacular Ceramics of Liao Dynasty]. *Zijin Cheng 紫禁城* (03).
- Cao Jianhua et al. 曹建华等 1999. *Lin Huang Shi Ji 临潢史迹 [Historical Sites in Linhuang]*. Huhehaote: Neimenggu renmin chubanshe 内蒙古人民出版社.
- Cen Rui 岑蕊 1983. Mojie Wen Kaolue 摩羯纹考略 [a Brief Study of the Makara Motif]. *Wenwu 文物* (10):78-80, 85.
- Changpingxian wenguansuo 昌平县文管所 1993. Beijing Changping Chenzhuang Liaomu Qingli Jianbao 北京昌平陈庄辽墓清理简报 [a Brief Report on the Clearing up of Liao Tombs at Chenzhuang, Changping, Neijing]. *Wenwu 文物* (3):68-77.
- Chaoge Batu 朝格巴图 1992. Balin Youqi Wuzhuri Shan Faxian Yizuo Liao Mu 巴林右旗乌珠日山发现一座辽墓 [a Liao Tomb Found in Wuzhurishan, Balin Right Banner]. *Neimenggu wenwu kaogu 内蒙古文物考古* (Z1).
- Chaoyangshi bowuguan 朝阳市博物馆 1996. *Chaoyang Lishi Yu Wenwu 朝阳历史与文物*. Edited by 朝. Chaoyangshi bowuguan. Shenyang: Liaoning daxue chubanshe 辽宁大学出版社.
- 2004. Liaoning Chaoyang Zhaoduba Liao Bihua Mu 辽宁朝阳召都巴辽壁画墓 [a Liao Tomb with Mural Paintings at Zhaoduba, Chaoyang, Liaoning]. *Beifang wenwu 北方文物* (2):64-66.
- Chen Defu 陈德富 1994. Tang Sancai Yu Liao Sancai Zhi Bijiao 唐三彩与辽三彩之比较 [Comparison on Liao Three-Color Glazed Ceramics with Tang Ones]. *Songzhou xuekan 松州学刊* (6).

- Chen Fengshan et al. 陈凤山 2004. Neimenggu Chenba'erhuqi Bayankuren Liaodai Muzang Qingli Baogao 内蒙古陈巴尔虎旗巴彦库仁辽代墓葬清理报告 [Excavation Report of the Clearing of the Liao Tombs at Bayankuren, Chenba'erhu Banner, Inner Mongolia]. *Kaoguxue jikan 考古学集刊* (14):267-279.
- Chen Huasha 陈华莎 1995. Beijing Longquanwu Liao Wanqi Guanyao Ciqi De Bianxi 北京龙泉务辽晚期官窑瓷器的辨析 [Discrimination on Late Liao Official Ceramics of Longquanwu Kiln in Beijing]. *Shoucang jia 收藏家* (1).
- Chen Jinmei 陈金梅 2002. Liaoning Beipiao Shi Xiawafanggou Faxian Yi Zuo Liao Mu 辽宁北票市下瓦房沟发现一座辽墓 [a Liao Tomb Found in Xiawagou, Beipiao, Liaoning]. *Beifang wenwu 北方文物* (4):28-29.
- Chen Kelun 陈克伦 2000. Yelü Yuzhi Mu Chutu Taoci Yanjiu 耶律羽之墓出土陶瓷研究 [Study on Ceramics Unearthed from the Tomb of Yelü Yuzhi]. In *Caoyuan Guibao 草原瑰宝*. Shanghai: Shanghai bowuguan 上海博物馆.
- Chen Mingda 1980. *Yingxian Muta 应县木塔 [Ying County Timber Pagoda]*. Edited by M. Chen. Beijing: Wenwu chubanshe.
- Chen Shu 陈述 1978. *Qidan Shehui Jingji Shigao 契丹社会经济史稿 [a History of the Qidan Society and Economy]*. Beijing: Sanlian shudian.
- 1982. *Quan Liaowen 全辽文 [Complete Liao Writings]*. Edited by S. Chen. Beijing: Zhonghua shuju.
- Chen Tangdong & Li Xingsheng 陈棠栋 & 李兴盛 1988. Neimenggu Xinghe Jianshan Liao Mu Fajue Jianbao 内蒙兴和尖山辽墓发掘简报 [a Brief Report of Excavations on Liao Tomb in Jianshan, Xinghe, Inner Mongolia]. *Beifang wenwu 北方文物* (04):43-45.
- Chen Wanli & Feng Xianming 陈万里&冯先铭 1960. Gugong Bowuyuan Shinianlai Dui Guyaozhi De Diaocha 故宫博物院十年来对古窑址的调查 [the Investigations of Ancient Kiln Sites Carried out by the Beijing Place Museum During the Recent Ten Years]. *Gugong bowuyuan yuankan 故宫博物院院刊* (2):104-130.
- Chen Wanli 陈万里 1953. Xing Yue Eryaoji Dingyao 邢越二窑及定窑 [Xing , Yue and Ding Wares]. *Wenwu 文物* (9):91-106.
- 1956. Wo Duiyu Liaomu Chutu Jijian Ciqi De Yijian 我对于辽墓出土几件瓷器的意见 [My Opinion with Regard to Several Ceramic Pieces Unearthed from Liao Tombs]. *Wenwu 文物* (11):15-16.
- Chen Xianchang 陈项昌 1982. Bohai Guo Jingji Shitan 渤海国经济试探 [a Tentative Examination of the Bohai Economy] *Beifang luncong* (3):93-97.
- Chen Xiangwei & Wang Jianqun 陈相伟&王健群 1973. Jilin Zhelimumeng Kulunqi Yihao Liaomu Fajue Jianbao 吉林哲里木盟库伦旗一号辽墓发掘简报 [a Brief Report of the Excavations of Liao Tomb at Kulunqi, Zhelimumen, Jilin]. *Wenwu 文物* (8):2-18.

- Chen Xiangwei 陈相伟 1995. Jinlin Sheng Liaojin Kaogu Zongshu 吉林省辽金考古综述 [Summary on Liao and Jin Archaeological Works in Jilin Province] *Beifang wenwu 北方文物* (04).
- Chen Yaocheng et al. 陈尧成等 1992. Beijing Liaodai Liuli Qi Zhong De Peng You 北京辽代琉璃器中的硼釉 [Boron Glaze of Beijing Liuli Ware of Liao Dynasty]. In *Gu Taoci Kexue Jishu Guoji Taolunhui Lunwen Ji 古陶瓷科学技术国际讨论会论文集 [Proceedings of the 1989 International Symposium on Ancient Ceramics (Isac '89)]*, edited by J. Li, X. Chen, 李家治 and 陈显求. Shanghai: Shanghai kexue jishu wenxian chubanshe.
- 1995. A Study on Tang Blue and White Wares and Sources of the Cobalt Pigments Used. In *Science and Technology of Ancient Ceramics 3: Proceedings of the International Symposium (Isac '95)*, edited by J. Guo. Shanghai: Shanghai Research Society of Science and Technology of Ancient Ceramics.
- 1997. Beijing Longquanwu Liaojindai Ciqi Chubu Yanjiu 北京龙泉务辽金代瓷器初步研究 [a Preliminary Study on Porcelain of Beijing Longquanwu Kiln in Liao and Jin Dynasties] *Taoci xuebao 陶瓷学报 [Journal of Ceramics]* 18 (1):46-51.
- 1999a. Beijing Longquanwu Liao Jin Dai Heici De Zhizuo Gongyi He Xianwei Jiegou Yanjiu 北京龙泉务窑辽金代黑瓷的制作工艺和显微结构研究 [Study on Making Technique and Microstructure of the Liao and Jin White Glaze Wares from Longquanwu Kiln Site in Beijing]. *Zhongguo taoci 中国陶瓷* 35 (06):38-42.
- 1999b. Beijing Longquanwu Yao Liao Jin Dai Baici Yanjiu 北京龙泉务窑辽、金代白瓷研究 [Study on Liao and Jin White Porcelains of Longquanwu Kiln in Beijing]. *Hebei taoci 河北陶瓷* (02):3-9.
- Cong Wenyu et al., Baocong Guan, Yongchao Zhao, 丛文玉, 关宝琮, and 赵永超 1992. Liaodai Baici De Yanjiu 辽代白瓷的研究 [Study on Liao White Wares]. In *Gu Taoci Kexue Jishu Guoji Taolun Hui Lunwen Ji 古陶瓷科学技术国际讨论会论文集*, edited by Li Jiazhi & Chen Xianqiu 李家治 & 陈显求. Shanghai: Shanghai kexue jishu wenxian chubanshe.
- Cong Yanshuang 丛艳双 1992. Aluke'erqin Qi Daoerqige Faxian Yizuo Liaomu 阿鲁科尔沁旗道尔其格发现一座辽墓 [a Liao Tomb Found in Daoerqige, Aluke'erqin Banner]. *Neimenggu wenwu kaogu 内蒙古文物考古* (Z1):149-151.
- 1995. Aluke'erqin Liaodai Yizhi Shulue 阿鲁科尔沁旗辽代遗址述略 [Summary on Liao Sites in Aluke'erqin Banner]. In *Zhongguo Beifang Gudai Wenhua Guoji Xueshu Yantaohui Lunwen Ji 中国北方古代文化国际学术研讨会论文集*. Beijing: Zhongguo wenshi chubanshe.
- Coomaraswamy, Ananda K., and Francis Stewart Kershaw 1928. A Chinese Buddhist Water Vessel and Its Indian Prototype. *Artibus Asiae* 3 (2/3):122-141.
- Cosmo, Nicola Di 1994. Ancient Inner Asian Nomads: Their Economic Basis and Its Significance in Chinese History. *The Journal of Asian Studies* 53 (4):1092-1126.

- Crowe, Y 1975. Early Islamic Pottery and China. In *Transactions of the Oriental Ceramic Society*.
- Cui Fulai & Xin Jian 崔福来 & 辛建 1993. Qiqiha'er Shi Meilisi Changgang Liaomu Qingli Jianbao 齐齐哈尔市梅里斯长岗辽墓清理简报 [a Brief Report on Excavations of Liao Tombs at Changgang, Meilisi, Qiqiha'er]. *Beifang wenwu 北方文物* (01).
- Dai Hongwen 戴鸿文 1995. Liaoci Zhuangshi Fengge Shulue 辽瓷装饰风格述略 [Review on the Decorative Style of Liao Ceramis]. *Songzhou xuekan 松州学刊* (1).
- 2000. Liao Dai Sancai Qi Yanjiu 辽代三彩器研究 [Study on Liao Three-Color Glazed Ceramics]. *Gugong wenwu yuekan 故宫文物月刊* 18 (8).
- 2004. *Liao Dai Taoci Jianshang 辽代陶瓷鉴赏 [Appreciation on Liao Ceramics]*. Shenyang: Liaoning renmin chubanshe.
- Daly, Greg 1995. *Glazes and Glazing Techniques : A Glaze Journey*. London: A & C Black.
- Dan Huasha 丹化沙 1960. Heilongjiang Tailai Liaomu Qingli 黑龙江泰来辽墓清理 [Clearing up on Liao Tombs in Tailai, Heilongjiang]. *Kaogu 考古* (4).
- 1962. Heilongjiang Tailai Houwopu Tun Liaomu 黑龙江泰来后窝堡屯辽墓 [Liao Tomb in Houwobaotun, Tailai, Heilongjiang]. *Kaogu 考古* (3).
- Dantuxian wenjiaoju & Zhenjiang bowuguan 丹徒县文教局 & 镇江博物馆 1982. Jiangsu Dantu Dingmaoqiao Chutu Tangdai Yinqi Jiaocang 江苏丹徒丁卯桥出土唐代银器窖藏 [a Cache of Tang Silver Wares Has Been Unearthed at Dingmaoqiao, Dantu, Jiangsu]. *Wenwu 文物* (7):15-27.
- De Xin et al. 德新等 1994. Neimenggu Balin Youqi Qingzhou Baita Faxian Liaodai Fojiao Wenwu 内蒙古巴林右旗庆州白塔发现辽代佛教文物 [Liao Buddhist Relics Discovered in the White Pagoda at Qingzhou, Balin Right Banner, Inner Mongolia]. *Wenwu 文物* (12):4-33.
- Deng Baoxue et al. 邓宝学等 1983. Liaoning Chaoyang Liao Zhaoshi Zu Mu 辽宁朝阳辽赵氏族墓 [the Liao Tombs of the Zhao Family at Chaoyang, Liaoning]. *Wenwu 文物* (9):30-38.
- Di Cosmo, N. 2002. *Ancient China and Its Enemies: The Rise of Nomadic Power in East Asian History*: Cambridge University Press.
- Dien, Albert E. 1981. A Study of Early Chinese Armor. *Artibus Asiae* 43 (1/2):5-66.
- Ding Kejia 丁克家 1995. Xi Liao Wangchao De Yisilan Wenhua 西辽王朝的伊斯兰文化 [Islamic Culture in Westen Liao Dynasty]. *Ningxia xuekan 宁夏学刊* (1).
- Dingxian bowuguan 定县博物馆 1972. Hebeisheng Dingxian Faxian Liangzuo Songdai Taji 河北省定县发现两座北宋塔基 [the Foundations of Two Song Pagodas Have Been Discovered at Dingxian, Hebei Province]. *Wenwu 文物* (8):39-51, pl.6:1.

- Dittrich, Edith 1992. The Spread of the Lion Motif in Ancient Asia. In *Paper Presented at the International Academic Conference of Archaeological Cultures of the Northern Chinese Ancient Nations*. Hohhot.
- Dong Gao & Zhang Hongbo 董高&张洪波 1992. Liaoning Chaoyang Beita Tiangong Digong Qingli Jianbao 辽宁朝阳北塔天宫、地宫清理简报 [Brief Excavation Report on the Aboveground and Underground Palaces of the North Pagoda at Chaoyang, Liaoning]. *Wenwu 文物* (7):1-28.
- Dong Wenyi 董文义 1984. Balin Youqi Chaganba Shiyi Hao Liaomu 巴林右旗查干坝十一号辽墓 [Liao Tomb at Chaganba, Balin Right Banner]. *Neimenggu wenwu kaogu 内蒙古文物考古* (3):91-93.
- Dong Xinlin 董新林 2004. Liao Dai Muzang Xingzhi Yu Fengqi Lue Lun 辽代墓葬形制与分期略论 [General Discuss on Typology and Chronology of Liao Tombs]. *Kaogu 考古* (8).
- Dongbei bowuguan 东北博物馆 1951a. Fuxin Qidan Xiaoshi Mu Diaocha Baogao 阜新契丹萧氏墓调查报告 [Investigation Report on the Khitan Tombs of Xiao Family at Fuxin]. *Wenwu cankao ziliao 文物参考资料* 2 (9).
- 1951b. Liao Lijin Mu Fajue Baogao 辽李进墓发掘报告 [Excavation Report of Liao Tomb of Lijin]. *Wenwu cankao ziliao 文物参考资料* 2 (9).
- Du Xingzhi 都兴智 2003. Ershi Nian Lai Liao Dai Kaogu De Zhongyao Faxian Yu Yanjiu 二十年来辽代考古的重要发现与研究 [Important Discoveries and Studies on Liao Archaeology since Twenty Years]. In *Liao Jin Shi Yanjiu 辽金史研究*. Beijing: Zhongguo wenhua chubanshe.
- Duan Yiping 段一平 1983a. Jilin Shuangliao Liao Luotuoling Liaomu Qingli Jianbao 吉林双辽骆驼岭辽墓清理简报 [a Brief Report on Clearing up of Liao Tomb at Luotuoling, Shuangliao, Jilin]. *Kaogu yu wenwu 考古与文物* (6):43-46.
- 1983b. Zhemeng Kezuo Houqi Sulutu Liaomu 哲盟科左后旗苏鲁吐辽墓 [Liao Tomb at Sulutu, Keyou Rear Banner, Zhelimu Union]. *Wenwu ziliao congkan 文物资料丛刊* (7).
- Ebrey, Patricia Buckley 2003. *The Cambridge Illustrated History of China*. Cambridge: Cambridge University Press.
- Eisenhofer-Halim, Hannelore 1996. *Die Keramik Als Charakteristisches Phänomen Der Liao-Kultur (907 - 1125) in China : Formen- Und Materialsammlung Nach Chinesischen Fundberichten, Europäische Hochschulschriften Reihe 27, Asiatische Und Afrikanische Studien ; 57*. Frankfurt am Main ; Wien u.a.: Peter Lang.
- Elina-Qian., Xu *Historical Development of the Pre-Dynastic Khitan*. the Faculty of Arts at the University of Helsinki 2005 [cited. Available from <https://oa.doria.fi/dspace/bitstream/10024/829/1/historic.pdf>].

- Emerson, Julie, Jennifer Chen, Mimi Gardner Gates, and Seattle Art Museum. 2000. *Porcelain Stories : From China to Europe*. Seattle, WA: Seattle Art Museum in association with University of Washington Press.
- Fairbank, J. K., and D. C. Twitchett 1978. *The Cambridge History of China*: Cambridge University Press.
- Feng Enxue 冯恩学 1996. Liaodai Jiguanhu Leixingxue Tansuo 辽代鸡冠壶类型学探索 [Typological Study on Liao Cockscomb Bottle]. *Beifang wenwu 北方文物* (04):35-42.
- 1997. Beijing Zhaitang Bihua Mu De Shidai 北京斋堂壁画墓的时代 [Dating of the Liao Tomb with Mural Painting at Zhaitang, Beijing]. *Beifang wenwu 北方文物* (04).
- 1998. Diexie Dai: Qidan Wenhua Zhong De Tujue Yinsu 蹠蹠带 契丹文化中的突厥因素 [Diexie: The Turkic Element in Qidan Culture]. *Wenwu shijie 文物世界* (01):65-69.
- 1999. Neimenggu Kulun Liu Qi Hao Liaomu Bihua De Renwu Shenfen 内蒙库伦六、七号辽墓壁画的人物身份 [the Characters' Identification on the Mural Paintings of Liao Tombs and at Kulun, Inner Mongolia]. *北方文物* (03).
- 2001a. Dui Dishuihu Liaomu Bihua Zhi Shangque 对滴水壶辽墓壁画之商榷 [Discuss on the Mural Painting of a Liao Tomb at Dishuihu]. *Wenwu chunqiu 文物春秋* (06).
- 2001b. Hebeisheng Xuanhua Liaomu Bihua Tedian 河北省宣化辽墓壁画特点 [Fresco Features of the Liao Dynasty Tombs in Xuanhua, Hebei]. *Beifang wenwu 北方文物* (01).
- 2004. Liaodai Qidan Maju Tansuo 辽代契丹马具探索 [Exploring Liao Khitan Horse Gear]. In *Kaoguxue Jikan(14) 考古学集刊(14)*. Beijing: Wenwu chubanshe.
- 2005. Liaomu Qimen Tu Zhi Tansuo 辽墓启门图之探讨 [Discuss on the Qimen Figures on the Mural Paintings of Liao Tombs]. *Beifang wenwu 北方文物* (04).
- 2006. Tuerji Shan Liaomu Muzhu Shenfen Jiedu 吐尔基山辽墓墓主身份解读 [an Explanation About the Owner of the Tomb of Liao Dynasty at Tuerji Mountain]. *Minzu yanjiu 民族研究* (03).
- Feng Jiasheng 冯家昇 1936. Ri Ren Zai Dongbei De Kaogu 日人在东北的考古 [Japanese Archaeological Activities in Northeast China]. *Yanjing xuebao 燕京学报* (19).
- Feng Jiqin et al. 冯继钦等 1994. *Qidan Zu Wenhua Shi 契丹族文化史 [Cultural History of Khitan]*. Harbin: Heilongjiang renmin chubanshe 黑龙江人民出版社.
- Feng Jiqin 冯继钦 1989. Hala Qidan Ren Jianli De Qierman Wangchao 哈刺契丹人建立的起儿漫王朝 [the Kirman Kingdom Established by Qara-Khitan]. *Xinjiang daxue xuebao 新疆大学学报*.
- Feng Xianming et al., Victoria and Albert Museum, and Oriental Ceramic Society. 1970. *Kiln-Site Investigations, Chinese Translations ; No.5*. London: Victoria & Albert Museum in association with the Oriental Ceramic Society.

- Feng Xianming 冯先铭 1959a. Ciqi Qianshuo 瓷器浅说 [a Brief Discussion on Ceramics]. *Wenwu 文物* (7):67-70.
- 1959b. Henan Gongxian Guyaozhi Diaocha Jiyao 河南巩县古窑址调查纪要 [Synopsis of the Investigations of the Kiln Sites at Gongxian, Henan]. *Wenwu 文物* (9):56-58.
- 1965. Xingzhongguo Taoci De Zhuyao Shouhuo 新中国陶瓷的主要收获 [Major Ceramic Gains of New China]. *Wenwu 文物* (9):26-56.
- 1973. Woguo Taoci Fazhanzhong De Jige Wenti---Cong Zhongguo Chutu Wenwu Zhanlan Taoci Zhanpin Tanqi 我国陶瓷发展中的几个问题--从中国出土文物展览陶瓷展品谈起 [Some Problems with Regard to the Chinese Ceramic Development---Basing on the Ceramics Displayed in the Unearthed Chinese Cultural Exhibition]. *Wenwu 文物* (7):20-29.
- 1979. Youguan Linan Qian Kuan Mu Chutu Guan Xinguang Kuan Baici Wenti 有关临安钱宽墓出土官新官款白瓷问题 [Problems Concerning Guan- and Xinguan-Marked White Wares Unearthed from the Tomb of Qian Kuan at Linan]. *Wenwu 文物* (12): 27-28.
- 1981a. Sanshi Nian Lai Woguo Taoci Kaogu De Shouhuo 三十年来我国陶瓷考古的收获 [the Archaeological Achievement of Chinese Ceramics in the Past Thirty Years]. *Gugong bowuyuan yuankan 故宫博物院院刊* (1):3-27,50.
- 1981b. Tan Xingyao Youguan Zhu Wenti 谈邢窑有关诸问题 [a Discussion on Several Problems Concerning Xing Ware]. *Gugong bowuyuan yuankan 故宫博物院院刊* (4):49-55.
- 1983. Ding Yao 定窑 [Ding Ware]. In *Zhongguo Taoci 中国陶瓷 [Chinese Ceramics]*, edited by Zhongguo taoci bianji weiyuanhui. Shanghai: Shanghai renmin meishu chubanshe.
- 1984. Shanxi Hunyuan Gu Yaozhi Diaocha 山西浑源古窑址调查 [Investigations on Ancient Kiln Sites at Hunyuan, Shanxi]. In *Zhongguo Gudai Yaozhi Diaocha Fajue Baogao Ji 中国古代窑址调查发掘报告集 [Collected Reports on Excavations of Ancient Chinese Kiln Sites]*, edited by 文. Wenwu bianji weiyuanhui. Beijing: Wenwu chubanshe.
- 1995. *Zhongguo Taoci 中国陶瓷 [Chinese Ceramics]*. Edited by X. 冯. Feng. Shanghai: Shanghai guji chubanshe.
- Feng Yongqian 冯永谦 1960. Liaoning Jianping Xinmin De Sanzuo Liaomu 辽宁省建平、新民的三座辽墓 [the Three Tombs at Xinmin and Jianping, Liaoning]. *Kaogu 考古* (2):15-24.
- 1975. Yemaotai Liaomu Chutu De Taociqi 叶茂台辽墓出土的陶瓷器 [the Ceramics Unearthed from a Liao Tomb at Yemaota]. *Wenwu 文物* (12):40-48.
- 1981a. Beipiao Liutiaogou Liao Mu 北票柳条沟辽墓 [Liao Tombs at Liutiaogou, Beipiao]. *Liaoning wenwu 辽宁文物* (1):36-40.

- 1981b. "Guan" He "Xin Guan" Zi Kuan Ciqi Zhi Yanjiu “官”和“新官”字款瓷器之研究 [Study on Guan and Xinguan Marked Ceramics]. In *Liaoning Sheng Kaogu Bowuguan Xuehui Chengli Dahui Huikan 辽宁省考古博物馆学会成立大会会刊*. Shenyang: Liaoning sheng kaogu bowuguan xuehui.
- 1981c. Xin Faxian De Jijian Liaodai Taoci 新发现的几件辽代陶瓷 [Several New Discovered Liao Ceramics]. *Wenwu 文物* (8):65-71.
- 1983. Liaoning Faku Qianshan Liao Xiaopaolu Mu 辽宁法库前山辽萧袍鲁墓 [the Liao Tomb of Xiao Paolu at Qianshan, Faku, Liaoning]. *Kaogu 考古* (7):624-635.
- 1984a. Chifeng Gangwayao Cun Liaodai Ci Yaozhi De Kaogu Xin Faxian 赤峰缸瓦窑村辽代瓷窑址的考古新发现 [New Archaeological Discoveries at the Liao-Dynasty Kiln Site at Gangwayao Village in Chifeng]. In *Zhongguo Gudai Yaozhi Diaocha Fajue Baogao Ji 中国古代窑址调查发掘报告集 [a Collection of Excavation Reports on Ancient Chinese Kiln Sites]*, edited by Wenwu bianji weiyuanhui. Beijing: Wenwu chubanshe.
- 1984b. Guan He Xin Guan Zikuan Ciqi De Yanjiu “官”和“新官”字款瓷器的研究 [Study on Guan and Xinguan Marked Ceramics]. In *Zhongguo Gudai Yaozhi Diaocha Fajue Baogao Ji 中国古代窑址调查发掘报告集 [Collected Reports on the Excavations and Investigation of Chinese Ancient Kiln Sites]*, edited by Wenwu bianji weiyuanhui. Beijing: Wenwu chubanshe.
- 1987. Jianguo Yilai Liaodai Kaogu De Zhongyao Faxian 建国以来辽代考古的重要发现 [Important Archaeological Discoveries of the Liao Dynasty since the Founding of the People's Republic of China]. In *Liao Jin Shi Lunyi 辽金史论集 [Collection of Articles on the History of the Liao and Jin]*, edited by Chen Shu 陈述. Shanghai: Shanghai guji chubanshe.
- 1992. Liaodai Taoci De Chengjiu Yu Tedian 辽代陶瓷的成就与特点 [Accomplishments and Features of Liao Ceramics]. *Liaohai wenwu xuekan 辽海文物学刊* (2).
- 1994a. Fake Yemaotai Liaomu 法库叶茂台辽墓 [Liao Tomb at Yematai, Faku]. In *Dongbei Kaogu Yanjiu 东北考古研究*. Zhengzhou Zhongzhou guji chubanshe.
- 1994b. Liaodai Bufen Zhou Xian Jindi Kao 辽代部分州县今地考 [Present-Location Identifications of Some Liao Cities and Counties]. *Beifang wenwu 北方文物* (04).
- 1994c. Liaoning Diqu Sanshi Nian Lai Liaodai Kaogu Shouhuo 辽宁地区三十年来辽代考古收获 [Achievements on Liao Archaeological Works around Liaoning Region in the Past Thirty Years]. In *Dongbei Kaogu Yanjiu 东北考古研究*. Zhongzhou guji chubanshe.
- 2001. Shenyang Baitabao Baita Niandai Bianyi 沈阳白塔堡白塔年代辨疑 [Doubt on Dating of Bai Pagoda at Baitabao, Shenyang]. *北方文物* (03).
- Finlay, Robert 1998. The Pilgrim Art: The Culture of Porcelain in World History. *Journal of World History* 9 (2):141-187.

- Francois, Louis 2003. Shaping Symbols of Privilege: Precious Metals and the Early Liao Aristocracy. *Journal of Song-Yuan Studies* (33):71-109.
- Franke, Herbert 1990. The Forest Peoples of Manchuria: Khitans and Jurchens. In *The Cambridge History of Early Inner Asia*, edited by S. Denis. Cambridge: Cambridge University Press.
- Franke, Herbert, and Hok-lam Chan 1997. *Studies on the Jurchen and the Chin Dynasty, Variorum Collected Studies Series*. Aldershot, U.K.: Ashgate Publishing.
- Franke, Herbert, and Denis Twitchett 1994a. *Alien Regimes and Border States, 710-1368*. Edited by T. Herbert Franke and Denis, *The Cambridge History of China*. Cambridge: Cambridge University Press.
- 1994b. *The Cambridge History of China, Vol. 6 Alien Regimes and Border States, 907 - 1368*. Cambridge: Cambridge University Press.
- Franke, Herbert, and Denis Crispin Twitchett 1998. *Jianqiao Zhongguo Liao Xi Xia Jin Yuan Shi, 907-1368 剑桥中国辽西夏金元史*. Translated by Shi Weimin and Chen Gaohua. Di 1 ban. ed. Beijing: Zhongguo she hui ke xue chu ban she.
- Frick, Fay Arrieh 1993. Possible Sources for Some Motifs of Decoration on Islamic Ceramics. *Muqarnas* 10 (Essays in Honor of Oleg Grabar):231-240.
- Fu Ning 傅宁 2006. Neimenggu Diqu Faxian De Liaodai Yisilan Boli Qi: Jiantan Liao Shiqi De Duiwai Maoyi He Wenhua Jiaoliu 内蒙古地区发现的辽代伊斯兰玻璃器——兼谈辽时期的对外贸易和文化交流 [Islamic Glass Wares Found in Inner Mongolia Region]. *Neimenggu wenwu kaogu 内蒙古文物考古* (02).
- Fu Weiguang & Jin Zhu 傅惟光 & 金铸 1989. Heilongjiang Sheng Longjiang Xian Heshang Xiang De Liaodai Shishi Mu 黑龙江省龙江县合山乡的辽代石室墓 [Liao Tomb at Heshan Township, Longjiang County, Heilongjiang Province]. *Beifang wenwu 北方文物* (04):32-35.
- Fu Zhanjun 富占军 1990. Neimenggu Shangdu Xian Qianhaizi Liao Mu 内蒙古商都县前海子村辽墓 [Liao Tomb at Qianhaizi, Shangdu, Inner Mongolia]. *Beifang wenwu 北方文物* (02):49-51.
- Fu Zongde 傅宗德 1988a. Liaoning Kazuo Xian Chutu Liaodai Jiguanhu 辽宁喀左县出土辽代鸡冠壶 [Liao Cockcomb-Bottle Unearthed from Kazuo, Liaoning]. *Kaogu 考古* (9):861-862.
- 1988b. Liaoning Kazuoxian Xinglong Gou Liao Mu 辽宁喀左县兴隆沟辽墓 [Liao Tomb at Xinglonggou, Kazuo, Liaoning]. *Kaogu 考古* (4):381-383.
- Fungpingshan Museum 1981. *Zhongguo Gu Yao Zhi Ci Pian Zhan Lan 16.9.1981-14.10.1981 中国古窑址瓷片展览 16.9.1981-14.10.1981 [Exhibition of Ceramic Finds from Ancient Kilns in China, 16.9.1981-14.10.1981]*. Hong Kong: Gai guan.

- Fushun shi bowuguan 抚顺市博物馆 1987. Fushun Shi Guangming Jie Liao Mu Fajue Jianbao 抚顺市光明街辽墓发掘简报 [Report on Excavation of Liao Tomb at Guangming Street, Fushun City]. *Liaohai wenwu xuekan 辽海文物学刊* (2).
- Fuxin shi bowuguan 阜新市博物馆 1997. Liaoning Fuxin Shi Qidan Liao Mu Qingli Jianbao 辽宁阜新市契丹辽墓清理简报 [a Brief Report on Clearing up of Liao Khitan Tombs at Fuxin, Liaoning]. In *Zhongguo Kaogu Jicheng (Dongbei Juan) 中国考古集成 (东北卷)*. Beijing: Beijing chubanshe.
- Fuxinshi wenhua ju wenwu zu 阜新市文化局文物组 1977. Liaoning Fuxinxian Liao Xu Wang Mu Qingli Jianbao 辽宁阜新县辽许王墓清理简报 [a Brief Report of the Clearing up of the Liao Tomb of Xu Wang at Fuxin County, Liaoning]. *Wenwu ziliao congkan 文物资料丛刊* (1):84-87.
- Gao Aijun ed. 高爱君 2001. *Chifeng Liao Mu Yanjiu 赤峰辽墓研究 [Study on Liao Tombs in Chifeng]*. Edited by Gao Aijun 高爱君, *Beifang Minzu Wenhua Congshu 北方民族文化丛书*. Harbin: Harbin chubanshe.
- Gao Liming et al., Hongjie Luo, and J. Wilcock 1988. Ceramic Change in Ancient China: A Study of Various Song Dynasty Kilns (960-1279 A.D.) and of the Jingdezhen Kiln Sites between the Dates 907 and 1795 A.D. Using Computerised Multivariate Statistics. *Science and archaeology* (30):15-21.
- Gao Song et al., Weiwei Jiang, Baijun Li, Hua Li, 高松, 江伟伟, 李白军, and 李晔 2006. Shanxi Datong Jiche Chang Liaodai Bihua Mu 山西大同机车厂辽代壁画墓 [Liao Tomb with Mural Paintings at Jichechang, Datong, Shanxi]. *Wenwu 文物* (10).
- Gao Zhixi 高至喜 1984. Changsha Chutu Tang Wudai Baiciqi De Yanjiu 长沙出土唐五代白瓷器的研究 [a Study of Tang and Five Dynasties White Wares Unearthed at Changsha]. *Wenwu 文物* (1):84-93.
- Garnsey, Wanda, and Rewi Alley 1983. *China, Ancient Kilns and Modern Ceramics : A Guide to the Potteries*. Canberra, Australia ; Miami, Fla.: Australian National University Press ;Books Australia [distributor].
- Ge Huating 葛华廷 1996. Liao Zuzhou Shishi Kao 辽祖州石室考 [Research on Stone Room in Zuzhou of Liao Dynasty]. *Beifang wenwu 北方文物* (01).
- Ge Wulian 葛雾莲 1990. Yixiang Beibu Shandong Zhong De Bage Liaodai Sancai Luohan 易县北部山洞中的八个辽代三彩罗汉 [Eight Liao Three-Colored Lohans in a Cave at the North of Yi County, Hebei] *Xin meishu 新美术* (04).
- Goto Shigeki ed. 後藤茂樹 1955. *Sekai Toji Zenshu 世界陶磁全集 [Catalogue of World Ceramics]*. Edited by Goto Shigeki 後藤茂樹. Tokyo: Shogakukan.
- 1976. *Sekai Toji Zenshu Vol. 11: Zui to 世界陶磁全集 11:隋唐 [Ceramic Art of the World Vol.11: Sui Tang]*. Edited by Goto Shigeki 後藤茂樹. Tokyo: Shogakukan 小学館.

- 1977. *Sekai Toji Zenshu Vol. 12: So* 世界陶磁全集 12: 宋 [Ceramic Art of the World Vol.12: Song]. Edited by Goto Shigeki 後藤茂樹. Tokyo: Shogakukan 小学館.
- 1978. *Chugoku No Toji---Shinshutsudo No Meihin* 中國の陶磁——新出土の名品 [Chinese Ceramics---from Recent Discoveries and Historical Collections]. Edited by Goto Shigeki 後藤茂樹. Tokyo: Shogakukan 小学館.
- 1981. *Sekai Toji Zenshu Vol. 13 :Ryo Kin Gan* 世界陶磁全集 13: 遼金元 [Ceramic Art of the World Vol.13: Liao, Jin, Yuan]. Edited by Goto Shigeki 後藤茂樹. Tokyo: Shogakukan 小学館.
- Goto Shintaro & Sugimura Yuzo 後藤真太郎 杉村勇造 1953. *Ryojun Hakubutsu-Kan Zuroku* 旅順博物館圖錄 [Illustrated Catalogue of the Lushun Museum]. Tokyo: the Zauho Press 座右寶.
- Gray, B. 1959. Liao Pottery. *Transactions of the Oriental Ceramic Society* (32).
- Gray, B . 1975. The Export of Chinese Porcelain to the Islamic World : Some Reflection on Its Significance for Islamic Art before 1400. In *Transactions of the Oriental Ceramic Society*.
- Gray, Basil 1984. *Sung Porcelain and Stoneware*. London: Faber.
- 1985a. The Lotus and the Dragon. London, British Museum. *The Burlington Magazine* 127 (986):303+313-314.
- 1985b. *Studies in Chinese and Islamic Art*. 2 vols. London: Pindar Press.
- Gregory, Ian 1977. *Kiln Building, Ceramic Skillbooks*. New York: Pitman/Watson-Guptill Publications.
- Gridley, Marilyn 1995. Three Buddhist Sculptures from Longquanwu and the Luohans from Yi Xian. *Oriental Art*:20-29.
- Gridley, Marilyn Leidig 1993. Chinese Buddhist Sculpture under the Liao : Free Standing Works in Situ and Selected Examples from Public Collections. Thesis (Ph D), New Delhi: Aditva(International Academy of Indian Culture and Aditya Prakashan, University of Kansas, 1985), New Delhi: Aditva.
- Guan Baocong & Ye Shuqing 关宝琮 & 叶淑卿 1985. Liao Sancai De Yanjiu 辽三彩的研究 [Study on Liao Three-Color Glazed Earthenware]. In *Zhongguo gudai taoci kexue jishu di erjie guoji taolun hui* 中国古代陶瓷科学技术第二届国际讨论会 , a26. Beijing.
- Guan Baocong et al. 关宝琮等 1981. Liao Baici Zaoxing Zhuangshi Yu Zhuangshi Jiyi 辽白瓷造型装饰与装饰技艺 [Formation, Decoration, and Technique of Liao White Wares].
- Guan Jianping 关剑平 2004. Yi Xuanhua Liaomu Bihua Wei Zhongxin De Fencha Yanjiu 以宣化辽墓壁画为中心的分茶研究 [Study on Fencha: Focus on the Mural Painting of Liao

- Tombs at Xuanhua]. *Shanghai jiaotong daxue xuebao (zhexue shehui kexue ban)* 上海交通大学学报(哲学社会科学版) (01).
- Guan Shanming & Sun Ji 關善明&孫机 2003. *Zhongguo Gudai Jin Shi 中國古代金飾 [Chinese Gold Ornaments]*. Hong Kong: Muwen Tang Fine Arts Publications Ltd . 沐文堂美術出版社.
- Guan Yaxin 关亚新 2002. *Liaojin Wenhua Bijiao Yanjiu 辽金文化比较研究 [a Comparison Study between Liao and Jin Cultures]*. *Heilongjiang minzu congkan 黑龙江民族丛刊* (01).
- Guo Cong & Wang Xiaoying 郭聪 & 王晓颖 2005. *Beijing Diqu Liao Jin Kaogu Lunwen Mulu 北京地区辽金考古论文目录 [Index of Papers on Liao and Jin Archaeology in Beijing Region]*. In *Beijing Liao Jin Wenwu Yanjiu 北京辽金文物研究*. Beijing: Yanshan chubanshe.
- Guo Tiangang et al. 郭添刚等 2000. *Fuxin Huangjiagou Liao Mu 阜新黄家沟辽墓 [Liao Tombs at Huangjiagou, Fuxin]*. In *Fuxin Liao Jin Shi Yanjiu 阜新辽金史研究*. Beijing: Zhongguo shehui chubanshe.
- Guo Tiangang 郭天刚 2002. *Guanshan Liao Mu Fajue Gaikuang 关山辽墓发掘概况 [General Introduction on Liao Tombs at Guanshan]*. In *Fuxin Liao Jin Shi Yanjiu 阜新辽金史研究*. Beijing: Zhongguo shehui chubanshe.
- Guo Yanyi 1987. Raw Materials for Making Porcelain and the Characteristics of Porcelain Waxes in North and South China in Ancient Times. *Archaeometry* 29 (1):3-19.
- Guo Zhimeng 1994. *Zhongguo Song Liao Jin Xia Ke Ji Shi [Science and Technology History of Song, Liao and Jin Dynasty of China]*. Di 1 ban. ed, *Bai Juan Ben Zhongguo Quan Shi ; 57*. Beijing: Ren min chu ban she : Xin hua shu dian Beijing fa xing suo jing xiao.
- Guo Zhizhong & Liu Bing 郭治中&刘冰 1998. *Gangwayao Kao Gu Fajue Zhongshu 缸瓦窑考古发掘综述 [Summary of the Excavations at Gangwayao Kiln Sites]*. In *Neimenggu chifengshi 1998 nian zhongguo beifang gudai wenhua guoji xueshu taolun hui 内蒙古赤峰市1998年中国北方古代文化国际学术讨论会*.
- Guo Zhizhong & Su Dong 郭治中&苏东 2005. *Chifeng Gangwayao Yizhi Chutu Liaojin Ciqi Juyao 赤峰缸瓦窑遗址出土辽金瓷器举要[Some Liao and Jin Ceramics Excavated in Gangwayaocun Kiln Sited at Chifeng City]*. In *Zhongguo Gutaoci Yanjiu Di Shiyi Ji 中国古陶瓷研究 第十一辑 [Chinese Ancient Ceramic Study]*, edited by z. g. xuehui. Beijing: Zijincheng chubanshe.
- Guojia wenwuju ed. 国家文物局 1995. *Zhongguo Wenwu Jinghua Da Cidian: Taoci Juan 中国文物精华大辞典-陶瓷卷 [Encyclopedia of Chinese Cultural Relics: Ceramics]*. Edited by Guojia wenwuju 国家文物局. Vol. 1. Shanghai: Shanghai cishu chubanshe.

- Gyllensvard, Bo 1965. *Chinese Ceramics in the Carl Kempe Collection*. Stockholm: Almqvist and Wiksell.
- 1971. *Chinese Gold and Silver in the Carl Kempe Collection*. New York: Asia Society.
- Gyllensvard, Bo . 1957. Tang Gold and Silver. *Bulletin of the Museum of Far Eastern Antiquities* (29).
- Hamer, Frank, and Janet Hamer 1975. *The Potter's Dictionary of Materials and Techniques*. London: A&C Black.
- Han Baoxing 韩宝兴 1994. Linyuan Wenjiatun Liaomu Fajue Jianbao 凌源温家屯辽墓发掘简报 [a Brief Report on Excavation of Liao Tomb at Wenjiatun, Lingyuan]. *Liaohai wenwu xuekan 辽海文物学刊* (1):23-27.
- 1995. Beipiao Jizhangzi Liaodai Bihua Mu 北票季杖子辽代壁画墓 [Liao Tomb with Mural Paintings at Jizhangzi, Beipiao]. *Liaohai wenwu xuekan 辽海文物学刊* (1):149-156.
- Han Guanghui 韩光辉 1989. Liaodai Zhongguo Beifang Renkou De Qianyi Jiqi Shehui Yingxiang 辽代中国北方人口的迁移及其社会影响 [the Population Migration and Its Social Affect of Northern China in Liao Dynasty]. *Beifang wenwu 北方文物* (02).
- Han Guoxiang 韩国祥 2000. Chaoyang Xishangtai Liao Mu 朝阳西上台辽墓 [Liao Tomb at Xishangtai, Chaoyang]. *Wenwu 文物* (07).
- Han Jianwu 韩建武 1996. Shilun Liaodai Jin Yin Qi De Fenqi Ji Tedian 试论辽代金银器的分期及特点 [a Tentative Discuss on Chronology and Feature of Liao Gold and Silver Wares]. In *Shanxi Bowuguan Guankan 陕西博物馆馆刊*. Xi'an: Xibei daxue chubanshe
- Han Maoli 韩茂莉 1999. *Liao Jin Nongye Dili 辽金农业地理 [Agricultural Geography of Liao and Jin Dynasties]*, *Dong Fang Li Shi Xue Shu Wen Ku*. Beijing: Shehui kexue wenxian chubanshe.
- Han Shiming 2002. *Liao Jin Sheng Huo Lue Ying 辽金生活掠影 [a Glimpse of Life in Liao Jin Dynasties]*. Di 1 ban. ed, *Mu Yu Shi Shu Wu. Sheng Huo Lue Ying*. Shenyang Shi: Shenyang chubanshe.
- Han Wei 韩伟 1998. Ouzhou Liuchuan Yu Shoucang De Liaodai Jin Yin Qi 欧洲流传与收藏的辽代金银器 [Liao Gold and Silver Wares Collected in Europe]. In *Yuan Wang Ji: Shaanxi Kaogu Yanjiusuo Huadan Sishi Zhounian Jinian Wenji Xia Ce 远望集——陕西考古研究所华诞四十周年纪念文集 下册*. Xi'an: Shanxi renmin meishu chubanshe.
- Hang Kan & Liu Wei 2001. *Liao Xia Jin Yuan: Caoyuan Digu De Rongyao 辽夏金元--草原帝国的荣耀 [Liao, Xia, Jin, Yuan: Glory of Steppe Empire]*. Shanghai;Hong Kong: Shanghai cishu chubanshe;Shangwu yinshuguan(Hong Kong) Ltd.

- Hangzhou shi wenwu kaogu yanjiusuo & Lin'an xian wenwu guan 杭州市文物考古所&临安县文物馆 2000. Zhejiang Lin'an Wudai Wu Yue Guo Kang Ling Fajue Jianbao 浙江临安五代吴越国康陵发掘简报 [a Brief Report of Excavations on Five Dynasties' Kang Mausoleum of Wuyue State at Lin'an Zhejiang]. *Wenwu 文物* (2).
- Hansford, Sidney Howard 1972. *A Glossary of Chinese Art and Archaeology*. 104 p. vols. London: China Society.
- Harada Yoshito 原田淑人 1939. *Tokyosei 东京城 [the Dongjing City]*. Tokyo: Toa koko gakkai.
- Hartman, J. M. 1973. *Exhibition of Liao Ceramics*. New York: China House Gallery.
- Hartwell, Robert M. 1982. Demographic, Political, and Social Transformations of China, 750-1550. *Harvard Journal of Asiatic Studies* 42 (2):365-442.
- Hartwell, Robert M., and University of Chicago. *Iron and Early Industrialism in Eleventh-Century China* 1963 [cited. Available from <http://libweb.cityu.edu.hk/cgi-bin/ezdb/umi-r.pl?T-09922.pdf> access full-text
- Hasebe Gakuji 長谷部樂爾 1965. A Few Problems in the History of Chinese Ceramics. *Myujiamu* (170-174):2-13.
- 1968. Chinese Ceramics. *Gekkan bunkazai* (62):21-29.
- 1996. *Ci Zhou Yao 磁州窯 [Cizhou Ware]*. Tokyo: Heibonsha Ltd Publishers 平凡社.
- Hasegawa Michitaka 長谷川道隆 1978. Ryo No Keikanko Ni Miru Yoshiki No Sui----Ryobo Shutsudo Shiryo Wo Chushin Ni 遼の雞冠壺にみる様式の推移——遼墓出土資料を中心に [Evolution of the Forms of Liao Bag-Shaped Pilgrim Flasks: Take the Unearthed Materials from Liao Tombs as the Center]. *Kodai Bunka 古代文化* (总 238 期 30 : 11).
- 1987. Ryo Kin, Gendai No Nagatsubo 遼、金、元代の長壺 [Slender Vases in Liao, Jin and Yuan Dynasties]. *Toyo toji 東洋陶磁 [Oriental ceramic]* 17:38-57
- Hasegawa Michitaka 長谷川道隆, and Yang Jing 杨晶译 1997. Liao Jin Yuan Dai De Changhu 辽、金、元代的长壺 [the Chicken-Leg Vases of Liao, Jin and Yuan Dynasties]. *Beifang wenwu 北方文物* (2).
- Hay, John 1987. The Persistent Dragon (Lung). In *The Power of Culture: Studies in Chinese Cultural History*, edited by A. H. P. a. Y.-s. Y. Willard J. Peterson. Hong Kong: Chinese University Press.
- He Li (Asian Art Museum of San Francisco) 1996. *Chinese Ceramics : A New Comprehensive Survey from the Asian Art Museum of San Francisco*. Edited by He Li. New York: Rizzoli.
- He Lin et al., Xiaoqing Liang, Zhongmin Lo, 贺林, 梁晓青, and 罗忠氏 1983. Xi'an Faxian Tangdai Jin Bei 西安发现唐代金杯 [a Tang Gold Cup Has Been Discovered at Xian]. *Wenwu 文物* (9):14.

- He Ming & Ma Hong 何明&马洪 1988. Jilin Qianguo Maoshang Liao Mu 吉林前郭茅山辽墓 [a Liao Tomb at Qianguomaoshan, Jilin]. *Kaogu 考古* (7).
- He Ming 何明 1982. Ji Hutacheng Chutu De Liao Jin Wenwu 记虎塔城出土的辽金文物 [a Report of Liao and Jin Relics Unearthed at the Huta City]. *Wenwu 文物* (7):44-49, fig.8.
- He Wenquan & Xiong Yingfei 2002. The Non-Destructive Composition Analysis of Ancient Porcelain Vessels. 1, Method Affirmance and Design. *Wenwu baohu yu kaogu kexue* 14 (Suppl.):272-283.
- 2003. Quantitative Analysis of Ancient Ceramic by X-Ray Spectroscopy Techniques. *Wenwu baohu yu kaogu kexue* 15 (3):13-20.
- He Wenquan Xiong Yingfei 2002. The Non-Destructive Composition Analysis of Ancient Porcelain Vessels. 2, Equipment Reconstruction and Quantitative Analysis. *Wenwu baohu yu kaogu kexue* 14 (Suppl.):284-297.
- He Xianwu & Zhang Xingde 何贤武 & 张星德 1996. Liaoning Faku Xian Yemaotai Ba Jiu Hao Liao Mu 辽宁法库县叶茂台八、九号辽墓 [Liao Tomb and at Yemaotai, Faku, Liaoning]. *Kaogu 考古* (6):41-47.
- He Yong & Pang Ruixiang 贺勇 & 庞瑞祥 1990. Hebei Shangyi Hulun Cun Faxian Liaodai Shiguan Mu 河北尚义囿村发现辽代石棺墓 [Liao Tomb with Stone Coffin at Hulun Village, Shangyi, Hebei]. *Wenwu chunqiu 文物春秋* (4):21-26.
- He Yong 贺勇 1990. Hebei Zhuolu Tanzhuang Liao (Wucheng) Zhijin Mu 河北涿鹿谭庄辽臧知进墓 [Liao Tomb of Zang Zhijin at Tanzhuang, Zhuolu, Hebei]. *Wenwu chunqiu 文物春秋* (03).
- 1991. Hebei Huai'an Xian Zhangjiatun Liao Mu 河北怀安县张家屯辽墓 [Liao Tomb at Zhangjiatun, Huai'an, Hebei]. *Kaogu 考古* (1).
- 1993. Huailai Xian Sangyuan Faxian Liao Jin Shidai Muzang 怀来县桑园发现辽金时代墓葬 [Liao and Jin Tombs Found at Sangyuan, Huailai]. *Wenwu chunqiu 文物春秋* (2).
- Hebei lincheng xingci yanzhi xiaozu 河北临城邢瓷研制小组 1981. Tang Dai Xingyao Yizhi Diaocha Baogao 唐代邢窑遗址调查报告 [Investigation Report on Xing Kiln Sites of Tang Dynasty]. *Wenwu 文物* (9):37-43.
- Hebeisheng bowuguan Wenwu guanlichu 河北省博物馆文物管理处 1980. *Hebeisheng Chutu Wenwu Xuanji 河北省出土文物选集* [Selected Cultural Relics Unearthed in Hebei Province]. Beijing: Wenwu chubanshe.
- Hebeisheng wenhuaju wenwu gongzuodui 河北省文化局文物工作队 1959. Yijiuwubanianlai Xingtai Diqu Liao Guyizhi Gumuzang De Faxian Qingli 一九五八年来邢台地区辽古遗址古墓葬的发现清理 [the Discovery and Clean up of Tomb Sites in the Xingtai Area in 1958]. (9):66-68.

- 1965. Hebei Quyangxian Jiancicun Dingyao Yizhi Diaocha Yu Shijue 河北曲阳县涧磁村定窑遗址调查与试掘 [Investigations and Trial Excavations of the Ding Kiln Sites at Jiancicun, Quyang County, Hebei]. *Kaogu* 考古 (8):394-412.
- Hebeisheng wenwu guanlichu et al. 河北省文物管理处, and Hebeisheng bowuguan 河北省博物馆 1975. Hebei Xuanhua Liao Bihuamu Fajue Jianbao 河北宣化辽壁画墓发掘简报 [a Brief Report of the Excavations of a Liao Tomb with Mural Paintings at Xuanhua, Hebei]. *Wenwu* 文物 (8):31-39.
- Hebeisheng wenwu yanjiusuo et al. 河北省文物研究所等 1995. Xuanhua Liaodai Bihua Mu Qun 宣化辽代壁画墓群 [Liao Tombs with Mural Paintings at Xuanhua]. *Wenwu chunqiu* 文物春秋 (02):1-22.
- Hebeisheng wenwu yanjiusuo 河北省文物研究所 1996. *Lidai Tongjing Wenshi* 歷代銅鏡紋飾 [Bronze Mirror Designs through the Ages]. Edited by Hebeisheng wenwu yanjiusuo 河北省文物研究所. Shijiazhuang: Hebei meishu chubanshe.
- 2001a. *Xuanhua Liaomu Bihua* 宣化遼墓壁画 [Tomb Murals of Liao Dynasty in Xuanhua]. Edited by Hebeisheng wenwu yanjiusuo 河北省文物研究所. Beijing: Wenwu chubanshe.
- 2001b. *Xuanhua Liaomu:1974-1993 Nian Kaogu Fajue Baogao* 宣化辽墓:1974-1993年考古发掘报告 [the Liao-Dynasty Tombs in Xuanhua: Reports on Archaeological Excavations from 1974 to 1993]. Edited by Hebeisheng wenwu yanjiusuo. 2 vols. Beijing: Wenwu chubanshe.
- Hebeisheng wenwuju 河北省文物局 2003. *Dingzhou Wenwu Cang Zhen* 定州文物藏珍 [Treasure of Cultural Relics in Dingzhou]. Edited by 河. Hebeisheng wenwuju. Guangzhou: Lingnan meishu Chubanshe.
- Heilongjiang wenwu kaogu gongzuodui & Jilin daxue lishi kaogu zhuanye 黑龙江文物考古工作队 & 吉林大学历史考古专业 1982. Heilongjiang Dongningxian Dachengzi Bohai Mu Fajue Baogao 黑龙江东宁县大城子渤海墓发掘简报 [a Brief Report of the Investigations of the Bohai Tombs at Dachengzi, Dongning County, Heilongjiang]. *Kaogu* 考古 (3):275-280.
- Henansheng bowuguan 河南省博物馆 1972. Henan Anyang Beiqi Fan Cui Mu Fajue Jianbao 河南安阳北齐范粹墓发掘简报 [a Brief Report of the Excavations of the Northern Qi Tomb of Fan Cui at Anyang, Henan]. *Wenwu* 文物 (1):47-57.
- Henansheng wenwu gongzuodui 河南省文物工作队 1964. Henansheng Mixian Dengfeng Tang Song Yaozhi Diaocha Baogao 河南省密县登封唐宋窑址调查报告 [a Report of the Investigations of Tang and Song Kiln Sites at Dengfeng, Mixian, Henan Province]. *Wenwu* 文物 (2):54-62.
- Hetherington, Arthur Lonsdale 1948. *Chinese Ceramic Glazes*. 114 p. : ills. (part col.) vols. South Pasadena, California: P.D. and I. Perkins.

- 1949. Chinese Ceramic Glazes with Special Reference to Those Derived from Copper. *Nature* 163:900.
- Hiroshi Kinoshita 2004. Hybridity and Conquest: Patterns of Liao (Ad 907-1125) Khitan Tomb Burial. In *Cultural Interaction and Conflict in Central and Inner Asia*, edited by U. E. B. a. G. L. Michael Gervers. Toronto: University of Toronto Asian Institute.
- 2006. *Burial Practices of the Liao (907-1125) Khitan Elite: A Reflection of Hybrid Culture*. Oxford: Ph.D. dissertation University of Oxford.
- Ho Chuimei 1990. *Ancient Ceramic Kiln Technology in Asia, Centre of Asian Studies Occasional Papers and Monographs*; Hong Kong: Centre of Asian Studies, University of Hong Kong.
- Hodges, H. W. M. 1988. The Formation of Crazeing in Some Early Chinese Glazed Wares. In *The Conservation of Far Eastern Art: Preprints of the Contributions to the Kyoto Congress, 19-23 September 1988*, edited by J. S. Mills, P. Smith and K. Yamasaki. London: International Institute for Conservation of Historic and Artistic Works.
- Honey, William Bowyer 1945. *The Ceramic Art of China and Other Countries of the Far East*. London: Faber.
- Hong Hao et al. 洪皓, Shiqi Gao, Ferdinand Verbiest, Shoutu Lin, Dacheng Wu, Dacheng Wu, Yougu Chang, and Shutian Li 1986. *Song Mo Ji Wen 松漠紀聞 [Records of Hearsay on the Pine Forests North of the Desert]*. Changchun: Jilin wenshi chubanshe.
- Hong Huanchun 1995. *Song Liao Xia Jin 宋辽夏金 [Song, Liao, Xia and Jin Dynasty]*. Beijing di 1 ban. ed, *Zhongguo Xiao Tong Shi*. Beijing: Zhongguo qing nian chu ban she.
- Hong Xiaoping 2006. *Yao Shi Jin Cai : Qidan Wang Chao Huang Jin Gui Bao*. Taiwan: Yourong gu wen wu yi shu.
- Hou Feng 侯峰 1990. Liaodai Hushi Baqu Jinhe 辽代花式八曲金盒 [Liao Eight-Lobbed Gold Box]. *Wenwu tiandi 文物天地* (3).
- Hu Jian et al. 胡健等 1987. Liao Sancai Long Yu Wen Hu 辽三彩鱼龙壶 [Liao Three-Glazed Markara Shaped Ewer]. *Liaohai wenwu xuekan 辽海文物学刊* (2).
- 1998. Fuxin Chenggou Liao Mu Qingli Jianbao 阜新程沟辽墓清理简报 [a Brief Report of Cleaning up of Liao Tomb at Chenggou, Fuxin]. *Beifang wenwu 北方文物* (02):25-28.
- Hu Jian et al. 胡健等 2002. Fuxin Diqu Liao Mu Fajue Yu Sangzang Xisu Qian Yi 阜新地区辽墓发掘与丧葬习俗浅议 [the Excavations on Liao Tombs in Fuxin Region and a Tentative Discuss on Burial Custom] In *Fuxin Liao Jin Shi Yanjiu 阜新辽金史研究 [Studies on Liao and Jin History in Fuxin]*. Beijing: Zhongguo shehui chubanshe.
- Hu Jiang & Zhang Guihua 胡健 张桂华 2003. Xishizhenbao Liao Dai Huangyou Taoqi 稀世珍宝辽代黄釉陶器 [Treasure of Liao Yellow Glazed Ceramics]. In *Liao Jin Shi Yanjiu 辽金史研究*. Beijing: Zhongguo wenhua chubanshe 中国文化出版社.

- Hu Xiujie 胡秀杰 1996. Liao Jin Shiqi Qidan Nüzhen Zu Gualeng Qi Yanjiu 辽金时期契丹女真族瓜棱器研究 [Study on Jurchen's Bowl-Mouth Bottle]. *Beifang wenwu* 北方文物 (02).
- Huang Fengqi 黄凤岐 1999. *Qidan Shi Yanjiu* 契丹史研究 [Study on Khitan History]. Huhehaote: Neimenggu kexue jishu chubanshe 内蒙古科学技术出版社.
- 2000. Qidan Nabo Wenhua Tan Lun 契丹捺钵文化探论 [a Tentative Discuss on Khitan's Nabo Culture]. *Shehui kexue jikan* 社会科学辑刊 (04).
- 2002. Qidan Zu Diaosu Yishu 契丹族雕塑艺术 [Statuary Art of Khitan]. In *Fuxin Liao Jin Shi Yanjiu* 阜新辽金史研究. Beijing: Zhongguo shehui chubanshe.
- Huang Xiuchun et al. 黄秀纯等 1994. Lue Lun Longquanwu Yaozhi Guishu Wenti 略论龙泉务窑址归属问题 [Slightly Discuss on the Attribution of Longquanwu Kiln Sites]. *Beijing wenwu yu kaogu* 北京文物与考古 (4).
- 1997. Mentougou Qu Longquanwu Gu Ci Yaozhi 门头沟区龙泉务古瓷窑址 [Longquanwu Kiln Sites in Mentougou District]. In *Zhongguo Kaogu Xue Nianjian (1994 Nian)* 中国考古学年鉴 (1994 年). Beijing: Wenwu chubanshe.
- Huang Xiuchun et al. 黄秀纯等, and Beijingshi wenwu gongzuodui 北京市文物工作队 1984. Liao Hanyi Mu Fajue Baogao 辽韩佚墓发掘报告 [a Report of the Excavations of the Liao Tomb of Han Yi]. *Kaogu xuebao* 考古学报 (3):361-381.
- Huang Xiuchun 黄秀纯 1989. Liaodai Hanyi Mu 辽代韩佚墓 [Liao Tomb of Han Yi]. *Beijing kaogu xinxi* 北京考古信息 (2).
- 1997. Beijing Longquanwu Yaozhi Jianjie 北京龙泉务窑址简介 [Biref Introduction on Longquanwu Kiln Site in Beijing]. *Beijing wenbo* 北京文博 (2).
- 2000. Longquanwu Yaoju Ji Zhuangshao Gongyi 龙泉务窑具及装烧工艺 [the Kiln Instruments and Loading Technique of Longquanwu Kiln]. In *Beijing Kaogu Jicheng* 北京考古集成 [Collected Papers on Peking Archaeology]. Beijing: Beijing chubanshe.
- 2001. Longquanwu Yaozhi Liao Dai Ciqi Zaoxing Ji Zhuangshi Gongyi 龙泉务窑址辽代瓷器造型及装饰工艺 [the Decorative and Formative Technique of Liao Ceramics from Longquanwu Kiln Sites]. In *首都博物馆丛刊15辑*. Beijing: Yanshan Chubanshe.
- 2006. Liao Hanyi Mu Chutu Yueyao Qingci 辽韩佚墓出土越窑青瓷 [Green Glazed Porcelains Unearthed from Han Yi Tomb of Liao Dynasty]. *Shoucang jia* 收藏家 (09).
- Huang Xueyin 黄雪寅 2003. Qidan Zu Jinyin Qi De Dongwu Wenshi 契丹族金银器的动物纹饰 [Animal Decoration Designs on Gold and Silver Wares of Khitan]. *Beifang wenwu* 北方文物 (03).
- Huang Zhenyun 黄震云 1995a. Liaodai Huihua Yishu 辽代绘画艺术 [Painting of Liao Dynasty]. *Zhongguo wenhua yanjiu* 中国文化研究 (02).

- 1995b. Liaodai Lisu 辽代礼俗 [Ritual and Custom of Liao Dynasty]. *Neimenggu shehui kexue(han wen ban)* 内蒙古社会科学(汉文版) (02).
- Hughes-Stanton, Penelope, Rose Kerr, British Museum, and Oriental Ceramic Society 1981. *Kiln Sites of Ancient China : An Exhibition Lent by the People's Republic of China*. [London]: Oriental Ceramic Society.
- Hunansheng bowuguan 湖南省博物馆 1966. Hunan Changsha Shijiao Wudai Mu Qingli Jianbao 湖南长沙市郊五代墓清理简报 [a Brief Report of the Cleaning up of Five Dynasties Tombs on the Outskirts of Changsha, Hunan]. *Kaogu* 考古 (3):159-160.
- Huo Jiena 霍杰娜 2002. Liaomu Zhong Suojian Fojiao Yinsu 辽墓中所见佛教因素 [Buddhist Factors Seen from Liao Tombs]. *Wenwu shijie* 文物世界 (03):15-20.
- 2003. Yanyun Diqu Liao Dai Muzang Yanjiu 燕云地区辽代墓葬研究 [Study on Liao Tombs of Yanyun Rigion], Peking University 北京大学, Beijing.
- Idemitsu Bijutsukan 出光美術館 1979. *Sodai No Toji 宋代の陶磁 [Song Ceramics]*. Tokyo: Idemitsu bijutsukan.
- 1994. *Bower Collection: Chugoku Toji Meihinten パウアー・コレクション中国陶磁名品展 [Bower Collection: Exhibition of Chinese Ceramics]*. Tokyo: Idemitsu Bijutsukan.
- 1997. *Chika Kyuden No Iho: Chugoku Kahoku-Sho Teishu Hookuso Toki Shutsudo Bunbutsuten [Treasures from the Underground Palaces: Excavated Treasures from Northern Song Pagodas, Dingzhou, Hebei Province, China]*. Edited by B. Idemitsu. Tokyo: Idemitsu Bijutsukan.
- Imano Haruki 今野春樹 2001. Ryo No Yoseki 辽の窯址 [Liao Kiln Sites]. *Hirobo* 博望 (2).
- 2002. Ryodai Kitanbo Shutsudo Toki No Kenkyu 辽代契丹墓出土陶器の研究 [Study on Liao Ceramics Unearthed from Khitan Tombs of Liao Dynasty]. *Bushitsu Bunka* 物質文化 (72):21 ~ 42
- 2003a. Ryo No Kitanbo No Kenkyu 辽代契丹墓の研究 [Study on Khitan Tombs of Liao Dynasty]. *Kokogaku Zashi* 考古学雑誌 [Journal of the Archaeological Society of Nippon] 87 (3):157 ~ 192.
- 2003b. Ryodai Kitanbo Shutsudo Sogu Nitsuite 辽代契丹墓出土葬具について [Study on the Burial Objects Unearthed from Khitan Tombs of Liao Dynasty]. *Bushitsu Bunka* 物質文化 [Material culture. A Journal of archaeologico-folkloric studies] 5 (75):14 ~ 29
- 2004. Ryodai Kitanbo Shutsudo Bagu No Kenkyu 辽代契丹墓出土馬具の研究 [Study on the Harnesses Unearthed from Khitan Tombs of Liao Dynasty]. *Kodai* 古代 [Journal of the Archaeological Society of Waseda University] 7 (112):151 ~ 176

- Ji Liancheng 计连成 2000. Liao Qingling Youyou Zhongyao Faxian 辽庆陵又有重要发现 [Important Discovery from Qing Mausoleum of Liao Dynasty]. *Neimenggu wenwu kaogu 内蒙古文物考古* (2):1-16.
- Ji Ping & Ta La 吉平&塔拉 1997. Ningcheng Xian Maiwanggou Liaodai Mu De Fajue Jianbao 宁城县埋王沟辽代墓地发掘简报 [Brief Excavation Report on the Liao Tombs at Maiwanggou, Ningcheng County, Inner Mongolia]. In *Neimenggu Wenwu Kaogu Wenji [Essays on the Archaeology of Cultural Relics in Inner Mongolia]*, edited by J. Wei. Beijing: Zhongguo da baike quanshu chubanshe.
- Ji Ping 吉平 1997. Aohanqi Pijianggou Liaodai Muzang 敖汉旗皮匠沟辽代墓葬[a Liao-Dynasty Tomb at Pijianggou, Aohan Banner]. In *Neimenggu Wenwu Kaogu Wenji 内蒙古文物考古文集 [Essays on the Archaeology of Cultural Relics in Inner Mongolia]*, edited by Neimenggu wenwu kaogu yanjiusuo. Beijing 北京: Zhongguo dabaik quanshu chubanshe.
- Ji Ruoxin 嵇若昕 2000. Shuo Liao Yan 说“遼硯” [on Liao Inkstones]. *Gugong wenwu yue kan 故宫文物月刊 [The National Palace Museum Monthly of Chinese Art]* (6):37-49.
- Ji Xunjie 嵇训杰 1980. Liaochao Jingji Juyü 辽朝经济举隅 [Major Aspects with Regard to the Liao Society]. *Zhongguo shi yanjiu 中国史研究* (3):92-103.
- Ji Zong'an 纪宗安 1993. Guanyu Yelü Dashi He Xi Liao Jianguo Shiqi De Jige Wenti 关于耶律大石和西辽建国时期的几个问题 [About Yelü Dashi and Several Aspects on the Establishment of Werstern Liao]. *Xiyu yanjiu 西域研究* (4).
- 1994. Xi Liao Diguó De Jingji Yu Wenhua 西辽帝国的经济与文化 [Ecnomy and Culture of Qara Khitai]. *Xibei minzu yanjiu 西北民族研究* (1).
- 1996. *Xiliao Shi Lun: Yelu Dashi Yanjiu 西辽史论·耶律大石研究 [Discussion of Western Liao History]*. Urumqi: Xinjiang renmin chubanshe.
- Jia Congjiang 贾丛江 1994. Xi Liao Shiqi Zhongya Qidan Ren De Jingji Shenghuo 西辽时期中亚契丹人的经济生活 [Economic Life of Khitan People of Qara Khitai in Central Asia]. *Xiyu yanjiu 西域研究* (4).
- Jia W. M. 2006. Transition from Foraging to Farming in Northeast China: University of Sydney. Philosophical & history enquiries.
- Jia Zhoujie 贾洲杰 1966. Neimenggu Zhaomeng Liao Taizu Ling Diaochaji 内蒙古昭盟辽太祖陵调查记 [Investigation of the Mausoleum of Liao Taizu at Zhaowudameng, Inner Mongolia] *Kaogu 考古* (5):263-366.
- 1973. Chifeng Gangwayaocun Liaodai Ciyao Diaochaji 赤峰缸瓦窑村辽代瓷窑调查记 [a Record of the Investigations of the Liao Kiln Sites at Gangwayaocun, Chifeng]. *Kaogu 考古* (4):241-43.

- 1978. Qidan Sangzang Zhidu Yanjiu 契丹丧葬制度研究 [Study on Funeral System of Khitan]. *Neimenggu daxue xuebao (renwen shehui kexue ban)* 内蒙古大学学报(人文.社会科学版) (02).
- 1980. Neimenggu Lindong Beishanpo Liaodai Yizhi De Xingzhi Wenti 内蒙古林东北山坡辽代遗址的性质问题 [the Problem of the Nature of Liao Sites on the Slope North of Lindong, Inner Mongolia]. *Kaogu* 考古 (1):96-90.
- Jiang Niansi & FengYongqian 姜念思 & 冯永谦 1982. Liaodai Yongzhou Diaocha Ji 辽代永州调查记 [a Report of the Investigations of the Liao Yongzhou]. *Wenwu* 文物 (1):54-58.
- Jiang Niansi 姜念思 1981. Liaomu Bihua Chutan 辽墓壁画初探 [a Tentative Discuss on Mural Painting in Liao Tombs]. In *Liaoning Sheng Kaogu Bowuguan Xuehui Chengli Dahui Huikan* 辽宁省考古博物馆学会成立大会会刊. Shenyang: Liaoningsheng kaogu bowuguan xuehui.
- Jiang Xin et al., Lijuan Ma, Yongfang Yang, and 马丽娟 姜歆, 杨永芳 2005. Yisilan Jiao Zai Liao Chao De Chuanbo Yu Fazhan Tan Xi 伊斯兰教在辽朝的传播与发展探析 [a Tentative Discuss on the Spread and Development of Islam in the Liao Dynasty]. *Chifeng xueyuan xuebao(hanwen zhexue shehui kexue ban)* 赤峰学院学报(汉文哲学社会科学版) (6).
- Jiangxi sheng qingongye ting jingdezhen taoci yanjiusuo 江西省轻工业厅景德镇陶瓷研究所 1963. *Zhongguo De Ciqi* 中国的瓷器 [Chinese Ceramics]. Edited by 江. Jiangxi sheng qingongye ting jingdezhen taoci yanjiusuo. Beijing: Zhongguo caizheng jingji chubanshe.
- Jiao Congjiang 贾丛江 1997. Xi Liao Qidan Ren Shenghuo Fangshi Kaobian 西辽契丹人生活方式考辨 [Study on the Life Style of Khitan People in Qara Khitai]. *Xiyu yanjiu* 西域研究 (04).
- Jilinsheng wenwu guanli weiyuanhui 吉林省文物管理委员会 1958. Jilin Lishuxian Pianlianchengzhi Diaochaji 吉林梨树县偏脸城址调查记 [a Report of the Investigations of the Sites of Pianlian City at Lishu County, Jilin]. *Kaogu* 考古 (3):26-31.
- 1963. Jilin Lishuxian Pianliancheng Fuchaji 吉林梨树县偏脸古城复查记 [a Record of the Second Investigation of the Old City of Pianlian, Lishu County, Jilin]. *Kaogu* 考古 (11):612-615.
- Jilinsheng wenwugongzuodui 吉林省文物工作队 1984. Jilin Tongyuxian Jietun Liaomu 吉林通榆县结屯辽墓 [a Liao Tomb at Jietun, Tongyu County, Jilin]. *Wenwu* 文物 (9):859-861.
- Jin Fengyi & Xu Ji 靳枫毅 & 徐基 1985. Liaoning Jianchang Guishan Yi Hao Liaomu 辽宁建昌龟山一号辽墓 [Tomb at Guishan, Jianchang, Liaoning]. *Wenwu* 文物 (3):48-55.
- Jin Fengyi 靳枫毅 1980. Liaoning Qianchuanghucun Liaomu 辽宁朝阳前窗户村辽墓 [a Liao Tomb at Qianchuanghucun, Liaoning]. *Wenwu* 文物 (12):17-29.

- Jin Shen 金申 2003. Tan Hebei Yixiang Bafowa Liaodai Sancai Tao Luohan 谈河北易县八佛洼辽代三彩陶罗汉 [Discuss on Three-Color Glazed Lohan Earthenware from Bafowa, Yixian, Hebei]. *Wenwu chunqiu* 文物春秋 (02).
- Jin Yawen 金亚文 1985. Kulun Wuhao Liaomu Jianjie 库伦五号辽墓简介 [a Brief Introduction on Tomb at Kulun Banner]. *Neimenggu minzu daxue xuebao(shehui kexue ban)* 内蒙古民族大学学报(社会科学版) (02).
- Jin Yongtian 金永田 1984. Liao Shangjing Chengzhi Fujin Fosi Yizhi He Huozang Mu 辽上京城址附近佛寺遗址和火葬墓 [Buddhist Temple Ruins and Cremation Tombs near the Site of Liao Supreme Capital]. *Neimenggu wenwu kaogu* 内蒙古文物考古 (3):94-97.
- Jin Yufu et al. 金毓黻 1996. *Song Liao Jin Shi* 宋辽金史 [History of Song, Liao and Jin Dynasties]. Di 1 ban. ed, *Min Guo Cong Shu. Di 5 Bian* ; Shanghai: Shanghai shu dian.
- Jin Yufu 金毓黻 1956. Luelun Jinqi Chutu De Liaoguo Lishi Wenwu 略论近期出土的辽国历史文物 [a Brief Discussion on Some Liao Historical Relics Unearthed Recently]. *Kaogu* 考古 (4):1-4.
- Jin Zhu 金铸 1987. Heilongjiang Longjiang Xian Er Cun Gumuqun Diaocha 黑龙江龙江县二村古墓群调查 [Investigations on the Tombs at Ercun, Longjiang, Heilongjian]. *Beifang wenwu* 北方文物 (1).
- Johnson, Linda Cooke 1983. The Wedding Ceremony for an Imperial Liao Princess. Wall Paintings from a Liao Dynasty Tomb in Jilin. *Artibus Asiae* 44 (2/3):107-136.
- Ju Guilan 巨桂兰 1993. Liao Dai Sancai Kehua Jiguanhu 辽代三彩刻花鸡冠壶 [Liao Three-Colored Cockcomb Bottle with Carved Disigns]. *Wenwu tiandi* 文物天地 (5).
- Kalaqinqi wenhuaguan 喀喇沁旗文化馆 1977. Liaoning Zhaomeng Kalaqinqi Faxian Tangdai Liujinyinqi 辽宁昭盟喀喇沁旗发现唐代鎏金银器 [Some Tang Gilt Silver Wares Have Been Discovered at Kalaqinqi, Zhaowudameng, Liaoning]. *Kaogu* 考古 (5):327-334.
- Kamio Kazuharu 神尾弑春 1982. *Kittan Bukkyo Bunka Shi Ko* 契丹佛教文化史考 [Historical Researches on the History of Khitan Buddhism]. Tokyo: Daiichi Shobo 第一書房.
- Kara, Gyorgy 1986. Kitan and Jurchin. In *The World's Writing Systems*, edited by T. D. a. W. B. Peter. New York: Oxford University Press.
- Kato Hajime 加藤土師萌 1963. Tousansai Yuuyaku Kou 唐三彩釉薬考 [Tang Three-Color Glazes]. *Kobijutsu* 古美術 (1):38-46.
- Kau Chi Society of Chinese Art 1981. *Zhongguo Gu Dao Ci Zhan* 中国古代陶瓷展 [Exhibition of Ancient Chinese Ceramics], from the Collection of the Kau Ji Society of Chinese Art in Association with the Art Gallery, the Chinese University of Hong Kong, 19th December 1981 to 18th February 1982. Edited by K. Chinese University of Hong. 香港: 求知雅集.

- Kazuo Toyomasu 豊増一雄 2006. Ryoji Kara Koraitoiji He No Gijutsu No Kenkyu 遼瓷から高麗陶磁への技術伝播の研究 In *Kyushu Denryoku Wakate Kogeika Kokunaigai HakkenKenshuSeido Kenshu Hokokusho 九州電力若手工芸家国内外派遣研修制度研修報告書*. KYUSHU ELECTRIC POWER CO. 九州電力株式会社.
- Ke Dake 柯大课 1994. *Zhongguo Song Liao Jin Xia Xisu Shi 中国宋辽金夏习俗史 [Chinese Custumal History of Song, Liao, Jin and Xixia Dynasties]*. Vol. 56, Bai Juan Ben Zhongguo Quan Shi 百卷本中国全史 [Chinese History]. Beijing: Renmin chubanshe.
- Kerr, Rose, and Nigel Wood 2004. "China's Influence on World Ceramics." Science and Civilization in China. In *Ceramic Technology*. Cambridge: Cambridge University Press.
- Kerr, Rose, Nigel Wood, Mei-fen Ts'ai, and Fukang Zhang 2004. *Science and Civilisation in China Vol.5:12: Chemistry and Chemical Technology, Part : Ceramic Technology*. Cambridge: Cambridge University Press.
- Kessler, Adam T., and Natural History Museum of Los Angeles County. 1994. *Empires Beyond the Great Wall : The Heritage of Genghis Khan*. Los Angeles, Calif.: Natural History Museum of Los Angeles County.
- Kim Weixian 金渭显 1981. *Qidan De Dongbei Zhengce: Qidan Yu Gaoli Nüzhen Guanxi Zhi Yanjiu 契丹的东北政策--契丹与高丽女真关系之研究 [Northeast China Policy of Khitan: Study on the Relationship between Khitan and Jurchen]*. Taipei: Huashi chubanshe.
- 1994. Qidan Wenhua Dongchuan Yu Gaoli 契丹文化东传于高丽 [Khitan Culture Spreading Eastward to Goryeo]. In *Dongbei Ya Wenhua Yanjiu 东北亚文化研究 [Study on the Culture of Northeast Asia]*: Zhongzhou guji chubanshe.
- Komai Waai 駒井和愛 1952. Ryodai No Susho Doki Nitsuite 遼代の素焼土器について [on Earthenware of Liao Dynasty]. *Toyoshikai Kiyō 東洋史會紀要* (1).
- Komura Toshio 小村俊夫 1930. Tsubameshushiro Oyobi Gangguantun No Kokamaato 燕州城及缸官屯の古窯址 [Ancient Kiln Sites at Gangguantun and the Yanzhou City]. *Mitsurumo 滿蒙* (117).
- 1933. Minamimanshu "Ganguantun" Yoseki Nitsuite 南滿洲“江官屯”窯址に就て [Ganguantun Kiln Sites at the South of Manchuria]. *Toji 陶磁* (5:6).
- Koyama Fujio 小山富士夫 1936. Mitsurumo Iseki Shutsudo No Tokata 滿蒙遗迹出土の陶片 [Shards Unearthed from the Sites at Manmeng Region]. *Toki Koza 陶器講座* (12).
- 1946a. Keikanko 雞冠壺 [Bag-Shaped Pilgrim Flasks]. *Zauho 座右寶* (4 ~ 5).
- 1946b. Ryo Midori Uwagusuri Botanmon Hoshubin 遼綠釉牡丹文鳳首瓶 [Liao Green Glazed Phoenix-Head Vase with Peony Designs]. *Zauho 座右寶* (4 ~ 5).
- 1952. Ryo Midori Uwagusuri Botanmon Hoshubin 遼綠釉牡丹文鳳首瓶 [Liao Green Glazed Phoenix-Head Vase with Peony Designs]. *Yamato Bunka 大和文华* (5).

- 1967. 遼三彩壺 [Liao Three-Color Glazed Bottle]. In *古美術*: 三彩社.
- Koyama Fujio 小山富士夫, and Figgess John translated 1962. Liao Pottery Wares. *Transactions of the Oriental Ceramic Society* (vol. 34):69-81.
- KuanYu 匡瑜 1963. Jilin Fuyu Xian De Yizhuo Liao Mu 吉林扶余县的一座辽金墓 [a Liao Jin Tomb from Fuyu County of Jilin Province]. *Kaogu 考古* (11).
- Kuhn, Dieter 1996. *A Place for the Dead: An Archaeological Documentary on Graves and Tombs of the Song Dynasty(960-1279)*. Heidelberg: Edition Forum.
- Kuhn, Dieter 1997. *Die Kunst Des Grabbaus: Kuppelgräber Der Liao-Zeit (907-1125) [the Art of Tomb Building: Dome-Shaped Tombs of the Liao Period (907-1125)]*, *Würzburger Sinologische Schriften*. Heidelberg: Edition Forum.
- 1998. *How the Qidan Reshaped the Tradition of the Chinese Dome-Shaped Tomb, Würzburger Sinologische Schriften*,. Heidelberg: Edition Forum.
- 2000. Liao Architecture: Qidan Innovations and Han-Chinese Traditions? *T'oung Pao* (86):325-62.
- Kuroda Genji & Sugimura Yuzo 黒田源次 & 杉村勇造 1954. Ryo No Toji 遼代の陶磁 [Ceramics of the Liao Dynasty]. *陶説* (21).
- 1958. Ryo No Toji 遼の陶磁 [Ceramics of the Liao Dynasty]. In *Toji Zenshu 陶磁全集 [Corpus of Ceramics]*. Tokyo: Beibiyousha.
- Kuroda Genji et al. 黒田源次等 1973. Chifeng Gangwayaocun Liaodai Ciyao Diaocha Ji 赤峰缸瓦窑村辽代瓷窑调查记 [Records on the Investigations of Liao Kiln Sites in Gangwayao Village of Chifeng]. *考古* (4).
- Kuroda Genji 黒田源次 1955. Ryo Kin Toji 遼金陶磁 [Ceramics of Liao and Jin Dynasty]. In *Sekai Toji Zenshu:Sou, Ryo 世界陶磁全集 (宋遼篇) [Catalogue of the World's Ceramics: Song and Liao]*. Tokyo: Kawade Shobo 河出書房.
- Laing, Ellen Johnston 2003. *Auspicious Motifs in Ninth- to Thirteenth-Century Chinese Tombs*.
- Lamouroux, Christian 1997. Geography and Politics, the Song-Liao Dispute of 1074-75. In *China and Her Neighbours: Borders, Visions of the Other, Foreign Policy, 10th-19th Century*, edited by P. Sabine Dabringhaus and Roderich. Wiesbaden: Harrassowitz.
- Langfang shi wenwu guanlisuo et al. 廊坊市文物管理所等 2001. Langfang Anciqu Xi Yongfeng Cun Liaodai Bihua Mu 廊坊市安次区西永丰村辽代壁画墓 [Liao Tomb with Mural Painting at Xiyongfeng Village, Anci District, Langfang City]. *Wenwu chunqiu 文物春秋* (4):38-44.

- Langfang shi wenwu guanlisuo 廊坊市文物管理所 1996. Langfang Anci Qu Zhaigezhuang Nanjianta Liaomu 廊坊安次区翟各庄、南尖塔辽墓 [Liao Tombs at Nanjianta and Zhaigezhuang, in Anci District, Langfang]. *Wenwu chunqiu* 文物春秋 (4):9-12,58.
- Laufer, Berthold 1967. *Sino-Iranica: Chinese Contributions to the History of Civilization in Ancient Iran*. New York: Kraus Reprint Corporation.
- Lei Hongji 雷虹霁 1994. Liaodai Lüyou Jiguanhu 辽代绿釉鸡冠壶 [Green Glazed Cockcomb Bottle of Liao Dynasty]. *Lishi jiaoxue* 历史教学 (02).
- Leung P. L. et al., Stokes M. J., and Chen T. M. 1997. Xrf Analysis of Porcelains Excavated from the Guantai Kiln Site and Discussion of Their Production Technology. In *The Cizhou Kiln Site at Guantai (in Chinese)*, edited by P. U. ed. Department of Archaeology. Beijing: Cultural Relics Publishing House.
- Leung P. L. et al., Michael J. Stokes, Tiemei Chen, and Dashu Qin 2000. A Study of Ancient Chinese Porcelain Wares of the Song-Yuan Dynasties from Cizhou and Ding Kilns with Energy Dispersive X-Ray Fluorescence. *Archaeometry* 42 (1):129-140.
- Li Bo 李波 1995. Jianping Sanjia Xiang Liao Qindechang Mu Qiangli Jianbao 建平三家乡辽秦德昌墓清理简报 [a Brief Report on Clearing up of Liao Tomb of Qin Dezhang at Sanjia Township, Jianping] *Liaohai wenwu xuekan* 辽海文物学刊 (02):14-19.
- Li Dajun 李大钧 1997. Chaoyang Goumenzi Liaomu Qingli Jianbao 朝阳沟门子辽墓清理简报 [a Brief Report on Clearing up of Liao Tomb at Goumenzi, Chaoyang]. *Liaohai wenwu xuekan* 辽海文物学刊 (01):30-36.
- Li Dianfu 李殿福 1981. Cong Kaoguxue Shang Kan Tangdai Bohai Wenhua 从考古学上看唐代渤海文化 [an Examination of the Bohai Culture in the Tang Dynasty from an Archaeological Point of View]. *Xuexi yu tansuo* 学习与探索 (4):130-137.
- Li Dong et al. 李东等 2006. Kulun Liaomu Bihua De Yishuxing Chutan 库伦辽墓壁画的艺术性初探 [a Tentative Discuss on Artistry of the Mural Paintings in Liao Tombs at Kulun Banner]. *Bowuguan yanjiu* 博物馆研究 (01).
- Li Futong et al. 1968. *Huihu Yu Liao Chao Jian Guo Zhi Guan Xi* 回鹘与辽朝建国之关系 [the Part Played by the Uigurs in the Founding of the Liao Dynasty]. Chu ban. ed. Taipei shi: Wen feng chu ban she.
- Li Gaocai 力高才 2005. *Liao Jin Xijin Datong* 辽金西京大同 [Datong: The Western Capital of Liao and Jin Dynasties]. Taiyuan: Shanxi renmin chubanshe.
- Li Guizhi 李桂芝 1996. *Liao Jin Jian Shi* 辽金简史 [Brief History of Liao and Jin]. Di 1 ban. ed, *Da Xue Li Shi Cong Shu*. Fuzhou: Fujian ren min chu ban she.
- Li Guozhen & Guo Yanyi 1983. Study of Ding White Porcelain Manufactured During Various Dynasties in Ancient China. *Guisuanyan xuebao* 11 (3):306-313.

- Li Guozhen et al. 1986. The Development of Chinese White Porcelain. In *Technology and Style*, edited by W. D. Kingery. Easton, Pennsylvania: American Ceramic Society.
- Li He, and Asian Art Museum of San Francisco. 1996. *Chinese Ceramics : The New Standard Guide*. London: Thames & Hudson.
- Li Hongjun & Zhao Hong 李红军 & 赵红 1998. Liao Sancai Yu Tang Song Sancai De Jianbie Yanjiu 辽三彩与唐、宋三彩的鉴别研究 [Discriminations on Liao, Tang and Song Three-Color Glazed Ceramics]. *Meishu guancha 美术观察* (05).
- Li Hongjun 李红军 1983. Guanyu Liao Sancai He Jin Yuan Sancai Zhi Jianbie Wenti De Chubu Yanjiu 关于辽三彩和金元三彩之鉴别问题的初步探索 [a Preliminary Study of the Problem Relating to Differentiation between Liao Three-Colored Ware and Jin and Yuan Three-Colored Wares]. *Liaoning wenwu 辽宁文物* (4):38-41.
- 1989. Shilun Liaoning Chutu De Tang Sancai Qi Yu Liao Sancai Qi Jiqi Xiangguan Wenti 试论辽宁出土的唐三彩器与辽三彩器及其相关问题 [a Tentative Discuss on Liao and Tang Three-Color Glazed Wares Unearthed from Liaoning and Some Related Questions]. *Liaohai wenwu xuekan 辽海文物学刊* (1):185-194.
- 1992. Liaodai Sancai Wenpan Bian 辽代三彩温盘辨 [Discuss on Liao Three-Colored Warm-Dish]. *Liaohai wenwu xuekan 辽海文物学刊* (1):140-142.
- 1993. Baiyou Tiexiuhua Ji Xing Jiguanhu Bian 白釉铁锈花鸡形“鸡冠壶”辨 [Discuss on a Brown Painting White Glazed Cockcomb Bottle] *Liaohai wenwu xuekan 辽海文物学刊* (2).
- 1995a. Liaoci De Zaoxing Zhuangshi Yishu Jiqi Meixue Tezheng 辽瓷的造型、装饰艺术及其美学特征 [Formative, Decorative Arts and Aesthetic Characteristics of Liao Ceramics]. *Liaohai wenwu xuekan 辽海文物学刊* (01):108-115.
- 1995b. Lun Liaodai Jiguanhu De Fenqi Yanbian Jiqi Xiangguan Wenti 论辽代鸡冠壶的分期演变及其相关问题 [Phased Evolution and Related Issues on Liao Cockcomb Bottle]. *Songzhou xuekan 松州学刊* (2).
- 1997a. Liaoci Zuojia Yu Bianwei Yanjiu 辽瓷作假与辨伪研究 [Study on the Imitations and Identifications of Liao Ceramics]. *Meishu guancha 美术观察* (10).
- 1997b. Liaodai Baici Yu Beisong Dingyao Baici De Jianbei Yanjiu 辽代白瓷与北宋定窑白瓷的鉴别研究 [Identification Studies on Liao White Porcelains and Northern Song Ding Wares]. *Wenwu chunqiu 文物春秋* (Z1):57-60.
- 2003. *Liao Dai Taoci Jianding Yu Jiansang 辽代陶瓷鉴定与鉴赏 [Identification and Appreciation on Liao Ceramics]*. Nanchang: Jiangxi meishu chubanshe 江西美术出版社.
- Li Huibing & Li Zhiyan 李辉柄 & 李知宴 1980. Henan Lushan Duandianyao 河南鲁山段店窑 [the Duandian Kiln at Lushan, Henan]. *Wenwu 文物* (5):52-60.

- Li Huibing 李辉柄 1981. Tanddai Xingyao Yaozhi Kaocha Yu Chubu Tansuo 唐代邢窑窑址考察与初步探索 [the Investigations and Preliminary Survey of the Xing Kiln Sites of the Tang Dynasty]. *Wenwu 文物* (9):44-48.
- 1983. Dingyao De Lishi Yiji Yu Xingyao De Guanxi 定窑的历史以及与邢窑的关系 [the History of Ding Ware and Its Relationship with Xing Ware]. *Gugong bowuyuan yuankan 故宫博物院院刊* (3):70-77.
- 1984. Guanyu Guan Xinguan Kuan Baici Chandi Wenti De Tantaoyao 关于官新官款白瓷产地问题的探讨 [a Study of the Problem Relating to the Places of Manufacture of Guan- and Xinguan-Marked White Wares]. *Wenwu 文物* (12):58-96,90.
- 1993. *Songdai Guanyao Ciqi 宋代官窑瓷器 [Song Official Porcelains]*. Beijing: Zijincheng chubanshe.
- Li Jiazhi & Chen Xianqiu 李家治 & 陈显求 1992. Zhongguo Gudai Taoci Kexue Jishu Chengjiu 中国古代陶瓷科学技术成就 [Chinese Scientific and Technological Achievements of Ancient Ceramics]. In *Gu Taoci Kexue Jishu Guoji Taolunhui Lunwenji 古陶瓷科学技术国际讨论会论文集*, edited by L. J. C. X. 李. 陈显求. Shanghai.
- Li Jiazhi 李家治 1985. The Evolution of Chinese Pottery and Porcelain Technology. In *Ancient Technology to Modern Science*, edited by W. D. Kingery and E. Lense. Easton, Pennsylvania: American Ceramic Society.
- 1998. *Zhongguo Kexue Jishu Shi : Taoci Juan 中国科学技术史: 陶瓷卷 [History of Chinese Science and Technology: Ceramics]*. Beijing: Kexue chubanshe.
- Li Jinyun 李今芸 1984. Song Liao Maoyi Zhi Yanjiu 宋辽贸易之研究 [Study on the Trade between Song and Liao], Taiwan University, Taipei.
- Li Jinyun 李缙云 1991. Yipi Liaodai Jin Yin Qi De Chubu Yanjiu 一批辽代金银器的初步研究 [a Preliminary Study on Some Gold and Silver Wares of Liao Dynasty]. *Wenwu chunqiu 文物春秋* (03).
- 1994. Xu Ji Xin Chuxian De Yipi Liaodai Jin Yin Qi 续记新出现的一批辽代金银器 [Sequential Records on Some Newly Appeared Gold and Silver Wares of Liao Dynasty]. *Wenwu chunqiu 文物春秋* (02).
- 1999. Liushi Haiwai De Yipi Liaodai Jinyin Qi 流失海外的一批辽代金银器 [a Group of Gold and Silver Artifacts of the Liao Dynasty Now Scattered Abroad]. *Shoucangjia* (14):12-15.
- Li Lin 李琳 1993. Qidan De Dongbei Zhengce: Qidan Yu Gaoli Nuzhen Guanxi Zhi Yanjiu 契丹的东北政策——契丹与高丽、女真关系之研究 [Northeast Policy of Khitan: Study on the Relationships among Khitan, Goryeo and Jurchen]. *Man zu yanjiu 满族研究* (03).
- Li Lin 李霖 1990. Hebei Chengde Xian Daobeigou Cun Liao Mu 河北承德县道北沟村辽墓 [Liao Tomb at Beigou Village, Chengde, Hebei]. *Kaogu 考古* (12).

- Li Mingqin 李明琴 2006. Langfang Shi Heping Lijing Xiaoqu Liaodai Mu Qun 廊坊市和平丽景小区辽代墓群 [Liao Tombs at Hepinglijing Community, Langfang City]. *Wenwu chunqiu 文物春秋* (06).
- Li Pinqing 李品清 1988. Qidan Liaodai Wenwu Shulue 阜新辽代文物述略 [Brief Introduction on the Liao Cultural Relics from Fuxin]. *Liaojin qidan nüzhen shi yanjiu 辽金契丹女真史研究* (2).
- Li Qingfa & Li Yufeng 李庆发&李宇峰 1991. Jianping Xiyaoacun Liao Mu 建平西窑村辽墓 [Liao Tomb at Xiyao Village, Jianping]. *Liaohai wenwu xuekan 辽海文物学刊* (1):120-123.
- 1999. Liaoning Chaoyang Xian Liumugou Cun Liao Mu 辽宁朝阳县柳木匠沟村辽墓 [Liao Tomb at Liumujianggou Village, Chaoyang, Liaoning]. *Bowuguan yanjiu 博物馆研究* (2).
- Li Qingfa 李庆发 1981. Liaoyang Sandaohao Liaomu 辽阳三道壕辽墓 [a Liao Tomb at Sandaohao, Liaoning]. *Liaoning wenwu 辽宁文物* (1):41-42.
- 1986. Liaoning Longchang Liang Zuo Liao Jin Mu 辽宁隆昌两座辽金墓 [Liao and Jin Tombs at Longchang, Liaoning]. *Liaohai wenwu xuekan 辽海文物学刊* (2).
- Li Qingquan 李清泉 2003. Liao Dai Han Ren Bihua Mu Yanjiu: Yi Xuanhua Zhang Shi Jiazou Bihua Mu Qun Wei Zhongxin 辽代汉人壁画墓研究——以宣化张氏家族壁画墓群为中心 [Study on Liao Tombs of Han People with Mural Paintings: -Take the Zhang Family Mural Tombs' Group at Xunhuan as the Center] Zhongshan university, Guangzhou.
- Li Shaobing 李少兵 1989a. Ningcheng Xian Sanzuo Dian Liaodai Muzang 宁城县三座店辽代墓葬 [Three Liao Tombs at Sanzuodian, Ningcheng County]. In *Zhongguo Kaoguxue Nianjian(1988 Nian) 中国考古学年鉴 (1988 年)*. Beijing Wenwu chubanshe.
- 1989b. Ningcheng Xian Shanzui Cun Liaomu 宁城县山嘴村辽墓 [Liao Tomb at Sanzui Village, Ningcheng County]. In *Zhongguo Kaoguxue Nianjian (1989 Nian) 中国考古学年鉴 (1989 年)*. Beijing: Wenwu chubanshe.
- Li Shenru 2000. *Liao Shi Di Li Zhi Kao 辽代地理志考 [Reseach on Records of Liao Geography]*. Vol. 5, *Si Ku Wei Shou Shu Ji Kan. Di 7 Ji* . [Beijing]: Beijing chubanshe.
- Li Weiran 李蔚然 1963. Nanjing Zhonghuamen Wai Songmu 南京中华门外宋墓 [a Song Tomb Outside the Zhonghua Gate at Nanjing]. *Kaogu 考古* (6):343, 339, fig.2.
- Li Wenjie 李文杰 1996. *Zhongguo Gudai Zhitao Gonyi Yanjiu 中国古代制陶工艺研究 [Study on Pottery Making Technique of Ancient China]*. Beijing: Kexue chubanshe 科学出版社.
- Li WenXin 1962. Der Keramische Ofen Der Alten Stadt Liao Shang Ching/Lin Huang Fu in Lin Tung (Autonomes Gebiet Der Inneren Mongolei).Aus Dem Chinesischen Ubersetet Von Karl Ganter. *Zeitschrift für Sprache, Kunst und Kultur der Lander des Fernen Ostene* (IX).
- Li Wenxin et al. 李文信等 1962. Liaoning Kaozuoxian Liao Wang Yue Mu 辽宁喀左县辽王悦墓 [the Liao Tomb of Wang Yue at Kazuo County]. *Kaogu 考古* (9):479-487.

- Li Wenxin 李文信 1940. Yebaihou Xing Ji 叶柏寿行纪 [Notes on the Investigations in Yebaisou]. *Guoli zhongyang bowuguan shibao 国立中央博物馆时报* (5).
- 1951a. Dongbei Bowuguan Gaikuang 东北博物馆概况 [Overview on the Northeast Museum]. *Wenwu cankao ziliao 文物参考资料* (9).
- 1951b. Ri Kou Zai Dongbei Wenhua Qinlue De Zuixing 日寇在东北文化侵略的罪行 [Cultural Invasion of Japanese in Northeast China]. *Wenwu cankao ziliao 文物参考资料* (9).
- 1954. Yixian Qinghemen Liaomu Fajue Baogao 义县清河门辽墓发掘报告 [a Report of the Excavation at Qinghemen, Yixian, Liaoning]. *Kaogu xuebao 考古学报* (8):163-202.
- 1958a. Liaoci Jianshu 辽瓷简述 [a Biref Account of Liao Ceramics]. *Wenwu cankao ziliao 文物参考资料* (2):10-22.
- 1958b. Lindong Liao Shangjing Linhuangfu Gucheng Nei Ciyaozhi 林东辽上京临潢府故城内瓷窑址 [Kiln Sites inside the Old City of Linhuangfu at the Liao Main Capital, Lindong]. *Kaogu xuebao 考古学报* (2):97-107.
- Li Wenzhe 李文泽 1998. Liao Song Wenhua Jiaoliu Yu Qidan Wenming De Fazhan 辽宋文化交流与契丹文明的发展 [Communications of Liao and Song Culture and the Development of Khitan Civilization]. In *Songdai Wenhua Yanjiu 宋代文化研究 [Study on Song Culture]*. Chengdu: Bashu shushe.
- Li Xihou & Bai Bin 李锡厚 & 白滨 2003. *Liao Jin Xi Xia Shi 辽金西夏史 [History of Liao, Jin and Xixia]*. Di 1 ban. ed, *Zhongguo Duan Dai Shi Xi Lie 中国断代史系列 [Series of Chinese Dynastic History]*. Shanghai: Shanghai renmin chubanshe.
- Li Xihou et al.李锡厚等 2005. *Liao Xixia Jin Shi Yanjiu 辽西夏金史研究 [Study on Liao, Jin and Xixia History]*. Fuzhou: Fujian renmin chubanshe 福建人民出版社.
- Li Xihou 李锡厚 1991. *Yelü Abaoji Zhuan 耶律阿保机传 [Biography of Yelü Abaoji]*. Di 1 ban. ed. Changchun: Jilin jiaoyu chubanshe.
- 2006. *Liao Shi 辽史 [Liao History]*. Di 1 ban. ed, *Zhongguo Li Shi 中国历史 [Chinese History]*. Beijing: Renmin chubanshe.
- Li Xing 李星 1995. Huashuo Yu Long Bianhua: Mojie Wen 話說魚龍變化—摩羯紋 [Discussion on the Development of the Dragon . Fish Motif : Makara]. *Wenwu chungui* (3):72-3.
- Li Yiyou & Wei Jian 李逸友 & 魏坚 ed. 1994. *Neimenggu Wenwu Kaogu Wenji 内蒙古文物考古文集 [Essays on the Archaeology of Cultural Relics in Inner Mongolia]*. Edited by J. Li Yiyou and Wei. Vol. 1. Beijing: Zhongguo dabaike quanshu chubanshe.
- Li Yiyou 李逸友 1955. Neimenggu Wenhua Ju Pai Ren Diaocha Tuquan Xian Liao Jin Wenhua Yiji 内蒙古文化局派人调查突泉县辽金文化遗迹 [Investigations on Liao and Jin Cultural Relic Sites at Tuquan]. *Wenwu cankao ziliao 文物参考资料* (1):122-23.

- 1958a. Alukerqinqi Shuiquangou De Liaodai Bihuamu 阿鲁科尔沁旗水泉沟的辽代壁画墓 [a Liao Tomb with Mural Paintings at Shuiquangou, Alukerqinqi]. *Wenwu 文物* (4):72.
- 1958b. Neimenggu Ningcheng Xian Liaomu De Qingli 内蒙古宁城县辽墓的清理 [Clearing up on Liao Tombs at Ningcheng, Inner Mongolia]. *Kaogu tongxun 考古通讯* (4).
- 1959. Neimenggu Tuquanxian Faxian Liaodai Wenwu 内蒙古突泉县发现辽代文物 [Liao Cultural Relics Found at Tuquan, Inner Mongolia]. *Kaogu 考古* (4).
- 1961a. Liao Zhongjing Xi Cheng Wai De Gu Muzang 辽中京西城外的古墓葬 [Ancient Tombs Outside the Western City of Liao Central Capital]. *Wenwu 文物* (9).
- 1961b. Zhaowudameng Ningchengxian Xiaoliuzhangzi Liao Mu Fajue Jianbao 昭乌达盟宁城县小刘仗子辽墓发掘简报 [a Biref Report of the Excavations of Liao Tombs at Xiaoliuzhangzi, Ningcheng County, Zhaowudameng]. *Wenwu 文物* (9):44-49.
- 1963. Neimenggu Chutu Wenwu Gaishu 内蒙古文物概述 [General Account of Cultural Relics Excavated in Inner Mongolia]. In *Neimenggu Wenwu Xuanji 内蒙古文物选集 [Selected Relics of Inner Mongolia]*, edited by Neimenggu zizhiqu wenwu gongzuo dui. Beijing: Wenwu chubanshe.
- 1984. Neimenggu Qidan Kaogu Gongzuo De Huigu 内蒙古契丹考古工作的回顾 [Review on the Archaeological Works of Khitan in Inner Mongolia]. *Neimenggu wenwu kaogu 内蒙古文物考古* (3):8-12.
- 1986a. Liao Shangjing Yizhi 辽上京遗址 [the Remains of the Liao Supreme Capital]. In *Zhongguo Dabaiké Quanshu: Kaoguxue [中国大百科全书：考古学卷]*. Beijing: Zhongguo dabaiké quanshu chubanshe.
- 1986b. Liao Zhongjing Yizhi 辽中京遗址 [the Remains of the Liao Central Capital]. In *Zhongguo Dabaiké Quanshu: Kaoguxue* Beijing: Zhongguo dabaiké quanshu chubanshe.
- 1987a. Liaodai Dai Shi Kaoshi: Cong Liao Chenguo Gongzhu Fuma Hezangmu Chutu De Yaodai Tanqi 辽代带式考实——从辽陈国公主驸马合葬墓出土的腰带谈起. *Wenwu 文物* (11):29-35.
- 1987b. Luelun Liaodai Qidan Yu Hanren Muzang De Tezheng He Fenqi 略论辽代契丹与汉人墓葬的特征和分期 [Special Features and Analysis of Khitan Versus Han Chinese Tombs in the Liao Dynasty]. In *Zhongguo Kaogu Xuehui Diliuci Nianhui Lunwen Ji [Collection Of: Papers Prcsented at the Sixth Annual Meeting of the Chinese Institute of Archaeology]*. Beijing: Wenwu chubanshe.
- 1991. Liaodai Qidanren Muzang Zhidu Gaishuo 辽代契丹人墓葬制度概说 [Introductory Remarks on the Burial System of the Khitan in the Liao Period]. In *Neimenggu Dongbuqu Kaoguxue Wenhua Yanjiu Wenji 内蒙古东部区考古学文化研究文集 [Research Essays on*

Archaeological Culture of the Eastern Region of Inner Mongolia], edited by Neimenggu zizhiqu wenwu kaogu yanjiusuo. Beijing: Haiyang chubanshe.

- 1992. Lun Liaomu Huaxiangshi De Ticao He Neirong 论辽墓画像石的题材和内容 [Discuss on Motif and Detail on Portrait Stone from Liao Tombs]. *Liaohai wenwu xuekan* 辽海文物学刊 (2).
- 1993. Lun Liaomu Bihua De Ticao He Neirong 论辽墓壁画的题材和内容 [Discuss on Motif and Detail on Portrait Stone from Liao Tombs]. *Neimenggu wenwu kaogu* 内蒙古文物考古 (1-2).
- Li Yufang 李毓芳 1982. Xianyang Shi Chutu Yijian Tangdai Jin Hu 咸阳市出土一件唐代金壶 [a Tang Gold Ewer Has Been Unearthed at Xianyang]. *Kaogu yu wenwu* 考古与文物 (1):54-58.
- Li Yufeng & Yuan Haibo 李宇峰 & 袁海波 1988. Liaoning Fuxin Liao Xiaojin Mu 辽宁阜新辽萧仅墓 [the Liao Tomb of Xiao Jin in Fuxin County, Liaoning Province]. *Beifang wenwu* 北方文物 (02):33-36.
- Li Yufeng et al. 李宇峰等 2003. Zhangwu Chaoyanggou Liaodai Mudi 彰武朝阳沟辽代墓地 [Liao Tombs at Chaoyanggou, Zhangwu]. In *Liaoning Kaogu Wenji* 辽宁考古文集 [Collection of Archaeological Papers on Liaoning], edited by Liaoningsheng wenwu kaogu yanjiusuo 辽宁省文物考古研究所. Shenyang: Liaoning minzu chubanshe.
- Li Yufeng 李宇峰 1982. Liaoning Chaoyang Chutu Tang Sancai Sanzu Guan 辽宁朝阳出土唐三彩三足罐 [a Tang Three-Colored Three-Footed Jar Has Been Unearthed at Chaoyang, Liaoning]. *Wenwu* 文物 (5):96.
- 1989a. Fuxin Faxian De Liao Ci Ban Er Hu 阜新发现的辽瓷板耳壶 [Liao Ewer with Single Handle Found in Fuxin]. *Zhongguo wenwu bao* 中国文物报, June 12.
- 1989b. Liaodai Jiguanhu Chubu Yanjiu 辽代鸡冠壶初步研究 [Preliminary Study on Liao Bag-Shaped Pilgrim Falsks]. *Liaohai wenwu xuekan* 辽海文物学刊 (1):195-200.
- 1991. Fuxin Hailiban Liao Mu 阜新海力板辽墓 [a Liao Tomb in Hailiban, Fuxin]. *Liaohai wenwu xuekan* 辽海文物学刊 (1):106-19,123.
- 1993a. Liaonin Diqu Jinian Liao Mu Yanjiu 辽宁地区纪年辽墓研究 [Study on Datable Liao Tombs in Liaoning Region] *Shenyang wenwu* 沈阳文物 (1).
- 1993b. Liaoning Fuxin Xian Daguben Liao Mu Fajue Jianbao 辽宁阜新县大固本辽墓发掘简报 [a Brief Report on Excavations of Liao Tomb at Daguben, Fuxin, Liaoning]. *Bowuguan yanjiu* 博物馆研究 (2):70-71,56.
- 1995. Liaoning Diqu Wei Jinian Liaomu Ji Xiangguan Wenti 辽宁地区未纪年辽墓及相关问题 [Undatable Liao Tombs in Liaoning Region and Related Questions]. In *Zhongguo Beifang Gudai Wenhua Guoji Xueshu Yantao Hui Lunwen Ji* 中国北方古代文化国际学术研讨会论文集. Beijing: Zhongguo wenshi chubanshe.

- 1997. Cong Chutu Wenwu Lue Shu Qidan Yu Zhongya De Wenhua Jiaoliu 从出土文物略述契丹与中亚的文化交流 [General Discuss on the Cultural Exchange between Khitan and Central Asia from the View of Unearthed Cultural Rilics] In *Zhongguo Kaogu Jicheng (Dongbei Juan)* 中国考古集成 (东北卷). Beijing: Beijing chubanshe.
- 2002a. Jian Guo Yilai Liaoning Diqu Liao Dai Chengzhi De Kaogu Faxian Yu Yanjiu 建国以来辽宁地区辽代城址的考古发现与研究 [Discoveries and Studies of Liao City Sites in Liaoning Region since 1949]. In *Fuxin Liao Jin Shi Yanjiu 阜新辽金史研究*. Beijing: Zhongguo shehui chubanshe.
- 2002b. Liaoning Zhangwu Chaoyanggou Liao Mu Fajue Gaikuang 辽宁彰武朝阳沟辽墓发掘概况 [Overview on the Excavations on Liao Tombs at Chaoyanggou, Zhangwu, Liaoning]. In *Fuxin Liao Jin Shi Yanjiu 阜新辽金史研究*. Beijing: Zhongguo shehui chubanshe.
- Li Zhanjie 李占杰 1997. Jiguanhu Yu Qidan Ren “鸡冠壶”与契丹人 [Cockcomb Bottle and Khitan People]. In *Zhongguo Kaogu Jicheng (Dongbei Juan)* 中国考古集成 (东北卷). Beijing: Beijing chubanshe.
- Li Zhenping 李珍萍 2005. Neimenggu Zizhiqiu Chutu Liao Jin Yu Nciqu Guoji Xueshu Yantaohui Shuyao 内蒙古自治区出土辽金元瓷器国际学术研讨会述要 [Notes on the International Symposium of Liao, Jian and Yuan Ceramics Unearthed from Inner Mongolia]. *Zhongguo wenwu bao 中国文物报*.
- Li Zhenshi 李振石 1980. Liaodai Sancai Yinhua Haitang Pan 辽代三彩印花海棠盘 [Liao Three-Colored Oblong Lobed Dish with Impressed Designs]. *Shehui kexue jikan 社会科学辑刊* (06).
- 1981. Liaodai Jiguanhu 辽代鸡冠壶 [Liao Cockcomb Bottle]. *Shehui kexue jikan 社会科学辑刊* (06).
- Li Zhiyan 李知宴 1972a. Tan Fan Cui Mu Chutu De Ciqi 谈范粹墓出土的瓷器 [a Discussion on the Ceramics Unearthed from the Tomb of Fan Cui]. *Kaogu 考古* (5):53-55.
- 1972b. Tang Dai Ciyao Gaikuang Yu Tangci De Fenqi 唐代瓷窑概况与唐瓷的分期 [a Brief Account of Tang Kilns and the Chronological Classification of Tang Ceramics]. *Wenwu 文物* (3):34-48.
- 1981. Xi'an Diqu Sui Tang Muzang Chutu Taoci De Chubu Yanjiu 西安地区隋唐墓葬出土陶瓷的初步研究 [a Preliminary Study of the Ceramics Unearthed from Sui and Tang Tombs in the Xian Area]. *Kaogu yu wenwu 考古与文物* (1):109-116, table 2.
- 1984. Handai Youtao De Qiyuan Yu Tedian 汉代釉陶的起源与特点 [the Origin and Characteristics of Han Lead-Glazed Ware]. *Kaogu yu wenwu 考古与文物* (2):91-95.
- 1985. Shanxi Hunyuan Jiezhuang Yao 山西浑源界庄窑 [Jiezhuang Kiln Site at Hunyuan, Shanxi]. *Kaogu 考古* (10):930-939.

- Liang Shuqin 梁淑琴 1981. Liaodai Jiguanhu De Leixing Biannian Ji Yanbian 辽代鸡冠壶的类型编年及演变 [a Chronicle and Development of the Types of the Liao Bag-Shaped Pilgrim Flask]. In *Liaoningsheng Kaogu Bowuguan Xuehui Chengli Dahui Huikan 辽宁省考古博物馆学会成立大会丛刊*.
- 1985. Liaodai Jiguanhu De Leixing Biannian Ji Yanbian 辽代鸡冠壶的类型、编年及演变 [Typology, Chronology and Evolution of Liao Bag-Shaped Pilgrim Flasks]. In *Liaoningsheng Bowuguan Xuehui Lunwenji Diyiji (1949-1984) 辽宁省博物馆学会论文集第一辑, 1949-1984*. Shenyang: Liaoningsheng bowuguan
- 1986. Cong Chutu Wenwu Kan Liaodai Qidan Zu Dui Han Zu Wenhua De Xishou He Jicheng 从出土文物看辽代契丹族对汉族文化的吸收和继承 [Khitan's Cultural Absorbtion and Inheritance from Han Culture of Liao Dynasty on the View of Unearthed Cultural Rilics]. *Liaojin qidan nüzhen shi yanjiu 辽金契丹女真史研究* (1).
- 1993. Lun Liaodai Long Wen Shi 论辽代龙纹饰 [Discuss on Dragon Designs of Liao Dynasty]. *Liaohai wenwu xuekan 辽海文物学刊* (2).
- 1994. Liaoci De Leixing Yu Fenqi 辽瓷的类型与分期 [Typology and Chronology of Liao Ceramics]. *Beifang wenwu 北方文物* (03):30-41.
- 1997. Lue Lun Liao Dai Long Wenshi 略論遼代龍紋飾 [on Liao Dragon Motifs]. In *Zhongguo Kaogu Jicheng : Dongbei Juan 中國考古集成:東北卷(14) [Collection of Archaeological Papers on China]*, edited by Sun Jinji & Feng Yongqian & Su Tianjun 孫進己 馮永謙 & 蘇天鈞. Beijing: Beijing chubanshe.
- Liang Wanlong 梁万龙 2000. Baoshan Liaodai Huangzu Bihua Mu Chu Kao 宝山辽代皇族壁画墓初考 [on the Liao Imperial Mural Tomb at Baoshan]. *Neimenggu shehui hexue (hanwen ban) 内蒙古社会科学(汉文版)* (4):54-57.
- Liang Zhenjing 梁振晶 2003. Fuxin Sijiazi Liaomu Fajue Baogao 阜新四家子辽墓发掘报告 [Excavation Report of a Liao Tomb at Sijiazi, Fuxin]. In *Liaoning Kaogu Wenji 辽宁考古文集 [Collection of Archaeological Papers on Liaoning]*, edited by Liaoningsheng wenwu kaogu yanjiusuo. Shenyang: Liaoning minzu chubanshe.
- Liang Zi 梁子 1998. Qian Lun Kaogu Ziliao Biaoxian De Liao De Cha Wenhua De Tedian 浅论考古资料表现的辽代茶文化的特 [Preliminary Discuss on Characteristic of Liao Tea Culture Shown in Archaeological Materials]. *Gugong wenwu yuekan 故宫文物月刊* 16 (3).
- Liao jin kaogu dui 辽金考古队 2000. Zhalute Liao Mu Faxian Jingmei Bihua 扎鲁特辽墓发现精美壁画 [Mural Paintings Found in Liao Tomb at Zhalute Banner]. *Zhongguo wenwu bao 中国文物报*, Oct.29.
- Liao Yongmin & Liu Hongmiao 2000. *Huangye Tang San Cai Yao 黄冶唐三彩窑 [Tang Three-Color Glazed Wares from Huangye Kiln Site]*. Beijing: Ke xue chu ban she.

- Liao Zhenjin & Wang Yi 梁振晶 &王毅 2004. Liaoning Fuxin Tizimiao Er San Hao Liaomu Fajue Jianbao 辽宁阜新梯子庙二、三号辽墓发掘简报 [a Brief Report on Excavations of Liao Tomb and from Tizimiao, Fuxin, Liaoning]. *Beifang wenwu 北方文物* (01):31-37.
- Liao Zhongjing fajue weiyuanhui 辽中京发掘委员会 1961. Liao Zhongjing Chengzhi Fajue De Zhongyao Shouhuo 辽中京城址发掘的重要收获[Important Gains from the Excavations at the City Ruins of the Liao Central Capital]. *Wenwu 文物* (9):34-40.
- Liaoning Chaoyang diqu wenwuzu 辽宁朝阳地区文物组 1978. Beipiao Koubuyingzi Liaomu Fajue Jianbao 北票扣卜营子辽墓发掘简报 [a Brief Report of the Excavations of a Liao Tomb at Koubuyingzi, Beipiao]. *Wenwu ziliao congkan 文物资料丛刊* (2):129-134.
- Liaoningsheng Balinzuoqi wenhuaguan 辽宁省巴林左旗文化馆 1979. Liao Shangjing Yizhi 辽上京遗址 [the Sites of the Liao Main Capital]. *Wenwu 文物* (5):79.
- Liaoningsheng bowuguan et al. 辽宁省博物馆等, and Liaoning Tieling diqu wenwu fajue xiaozu 辽宁铁岭地区文物发掘小组 1975. Faku Yemaotai Liaomu Jilue 法库叶茂台辽墓记略 [a Brief Record with Regard to a Liao Tomb at Yemaotai, Faku]. *Wenwu 文物* (12):26-36.
- Liaoningsheng bowuguan wenwu gongzuodui 辽宁省博物馆文物工作队 1980. Liaodai Yelu Yanning Mu Fajue Jianbao 辽代耶律延宁墓发掘简报 [a Brief Report of the Excavations of the Liao Tomb of Yelu Yanning]. *Wenwu 文物* (7):18-22.
- 1982. Liaoning Chaoyang Tang Mu Fajue Jianbao 辽宁朝阳唐墓发掘简报 [a Brief Report of the Excavations of Tang Tombs at Chaoyang, Liaoning]. *Wenwu ziliao congkan 文物资料丛刊* (6):86-101.
- Liaoningsheng bowuguan 辽宁省博物馆 1961. *Liaoning Sheng Bowuguan Cang Liaoci Xuanji 辽宁省博物馆藏辽瓷选集 [Selection of Liao Ceramics in Liaoning Provincial Museum]*. Edited by 辽. Liaoning sheng bowuguan. Beijing: Wenwu chubanshe.
- 1982. Ryorinsho Hakubutsu-Kan 遼寧省博物館 [the Liaoning Provincial Museum]. In *Chugoku No Hakubutsukan 中國の博物館 [Chinese Museums]*. Tokyo: Kodansha.
- 1983. *Liaoningsheng Bowuguan 辽宁省博物馆 [Liaoning Provincial Museum]*. Vol. 3, *Zhongguo Bowuguan Congshu 中国博物馆丛书 [Series of Chinese Museums]*. Beijing: Wenwu chubanshe.
- 1994. *Liaoci Jingxuan Tulu 辽瓷精选图录 [Selected Catalogue of Liao Ceramics]*. Edited by 辽. Liaoning sheng bowuguan. Shenyang: Liaoning meishu chubanshe 辽宁美术出版社.
- Liaoningsheng wenwu kaogu yanjiusuo et al. 辽宁省文物考古研究所 1992. Fuxin Nanzaoliyingzi Yi Hao Liao Mu 阜新南皂力营子一号辽墓 [Liao Tomb at Nanzaoliyingzi, Fuxin]. *Liaohai wenwu xuekan 辽海文物学刊* (1):54-63.

- Liaoningsheng wenwu kaogu yanjiusuo 辽宁省文物考古研究所 2002. Liaoning Sheng Beining Shi Baojia Xiang Taoyuan Cun Taipingtan Liao Mu 辽宁省北宁市鲍家乡桃园村大平滩辽墓 [Liao Tomb at Taipingtan, Taoyuancun, Baojia, Beining, Liaoning]. *Beifang wenwu 北方文物* (1):48-51.
- 2003. *Liaoning Kaogu Wenji 辽宁考古文集 [Collection of Archaeological Papers on Liaoning]*. Edited by L. w. k. y. 辽宁省文物考古研究所. Shenyang: Liaoning minzu chubanshe.
- Liaoyangshi wenwu guanlisuo 辽阳市文物管理所 1977. Liaoyang Faxian Liaomu He Jinmu 辽阳发现辽墓和金墓 [Liao and Jin Tombs Have Been Discovered at Liaoyang]. *Wenwu 文物* (12):90-91.
- Lin Maoyu & Xian Junyan 林茂雨 & 佺峻岩 2001. Faku Libeibao Liaomu 法库李贝堡辽墓 [Liao Tomb at Libeibao, Faku]. *Beifang wenwu 北方文物* (03):36-43.
- Lin Ronggui & Chen Liankai 林荣贵 & 陈连开 1987. *Wudai Shiguo Shiqi Qidan Shatuo Hanzu De Zhengzhi Jingji He Wenhua Jiaoliu 五代十国时期契丹, 沙陀, 汉族的政治, 经济和文化交流 [Political, Economical and Cultural Exchange among Khitan, Shatuo and Han Peoples in Five Dynasties]*. Beijing: Shumu wenxian chubanshe.
- Lin Ronggui 林荣贵 1995. *Liao Chao Jingying Yu Kaifa Beijiang 辽朝经营与开发北疆 [Managing and Developing the Northern Frontier in Liao Dynasty]*. Beijing: Zhongguo shehui kexue chubanshe.
- Lin Yang 林杨 1981. Tailai Xian Tazi Cheng Liaomu 泰来县塔子城辽墓 [Liao Tomb at Tazicheng, Tailai County]. *Beifang wenwu 北方文物* (01).
- Lin Yun 林运 1993. Liaodai Bihua Yanjiu Liangze 辽代壁画研究两则 [Study on Liao Mural Painting]. In *Qingguo Ji: Jilin Daxue Kaogu Zhuanye Chengli Ershi Zhounian Kaogu Lunwen Ji 青果集——吉林大学考古专业成立二十周年考古论文集*, edited by Jilin daxue kaogu xi. Beijing Zhishi chubanshe.
- Lindverg, G. 1953. Xingyao and Dingyao, an Investigation and Description of Some Chinese Tang and Song White Porcelain in the Carl Kempe and Gustaf Lindeberg Collections. *Bulletin of Museum of Far Eastern Antiquities* (no. 25):19-71.
- Linixian wenhuaguan 林西县文化馆 1980. Liao Raozhou Gucheng Diaochaji 辽饶州故城调查记 [a Record of the Investigations of the Liao Raozhou City]. *Kaogu 考古* (6):512-514.
- Liu Bing & Zhao Guochen 1993. Chifengshi Aluke'erqin Qi Wenduo'oruishan Liaomu Qingli Jianbao 赤峰市阿鲁科尔沁旗温多尔敖瑞山辽墓清理简报 [Brief Report on a Liao Tomb at Aoruishan, Wenduo'er, Aluke'erqin Banner, Chifeng City]. *Wenwu 文物* (3):57-67.
- Liu Bing et al. 刘冰等 1998. Chifeng a Qi Han Sumu Sumu Liao Mu Qingli Jianbao 赤峰阿旗罕苏木苏木辽墓清理简报 [Brief Report on Clearing up of Liao Tombs at Hansumusumu, Aluke'erqin Banner, Chifeng]. *Neimenggu wenwu kaogu 内蒙古文物考古* (1):26-34,38.

- Liu Bing 刘冰 1998. Gangwayao Kaogu Diaocha Zongshu 缸瓦窑考古调查综述 [Summary on the Archaeological Investigations of Gangwayaocun Kiln Site]. *Chifeng wenbo tongxun 赤峰文博通讯* (1).
- Liu Fengzhu et al. 刘凤翥等 1997. Liao Jin Xixia Shi 辽金西夏史 [History of Liao, Jin and Xixia]. In *Ershiwu Shi Xin Bian 二十五史新编*. Shanghai: Shanghai guji chubanshe.
- Liu Fengzhu 刘凤翥 1996. Liao Sancai Wenpan Huo Nuanpan Zhengming 辽三彩“温盘”或“暖盘”正名 [Naming Rectification of Liao Three-Colored Ceramics So Called Wenpan or Nuanpan]. *Liaohai wenwu xuekan 辽海文物学刊* (01):133-134.
- Liu Guixin 刘桂馨 1997. Liaodai Zunhua Mu Chutu De Weiqi Zi 辽代遵化墓出土的围棋子 [Chessmen Unearthed from Liao Tomb at Zunhua]. *Wenwu 文物* (11):62-66.
- Liu Haiwen & Yancheng 刘海文&颜城 1992. Hebei Sheng Xuanhua Xiabali Liao Hanshixun Mu 河北省宣化下八里辽韩师训墓 [Liao Tomb of Han Shixun at Xiabali, Xuanhua, Hebei]. *Wenwu 文物* (6):1-11.
- Liu Haiwen & Zhi haimei 刘海文 & 只海梅 2000. Hebei Xuanhua Liaomu Bihua Jianxi 河北宣化辽墓壁画简析 [Simply Discuss on Mural Paintings from Liao Tombs at Xuanhua, Hebei]. *Dongnan wenhua 东南文化* (10).
- Liu Haiwen et al. 刘海文等 1995. Hebei Xuanhua Liaodai Bihua Mu 河北宣化辽代壁画墓 [Liao Tombs with Mural Paintings at Xuanhua, Hebei]. *Wenwu 文物* (02).
- Liu Haiwen 刘海文 1996. Shishu Hebei Xuanhua Xiabali Liaodai Bihua Mu Zhong De Chadao Tu Ji Chaju 试述河北宣化下八里辽代壁画墓中的茶道图及茶具 [a Tentative Discuss on the Tea Ceremony Motif on Mural Paintings and Tea Vessels from Liao Tombs at Xiaobali, Xuanhua, Hebei]. *Nongye kaogu 农业考古* (02).
- Liu Huacheng 刘化成 2005. Langfang Guangyang Qu Mafang Cun Chutu De Liaodai Yiwu 廊坊广阳区马坊村出土的辽代遗物 [Liao Relics Unearthed from Mafang Village, Guangyang District, Langfang]. *Wenwu chunqiu 文物春秋* (05).
- Liu Jianhua 刘建华 1990. Huai'an Xian Xiping Shan Faxian Liao Dai Jiaocang Ciqi 怀安县西坪山发现辽代窖藏瓷器 [Liao Ceramics from a Hoard at Xipingshan, Huai'an County]. *Wenwu chunqiu 文物春秋* (03).
- Liu Jianzhong & He Yong 刘建忠 & 贺勇 1987. Hebei Zhuolu Xian Liaodai Bihua Mu Fajue Jianbao 河北涿鹿县辽代壁画墓发掘简报 [a Brief Report on Excavations of Liao Tombs with Mural Paintings at Zhuolu, Hebei]. *Kaogu 考古* (3).
- Liu Jianzhou 刘建洲 1981. Gongxian Tang Sancai Yaozhi Diaocha 巩县唐三彩窑址调查 [the Investigations of the Tang Three-Colored Ware Kiln Site at Gongxian]. *Zhongyuan wenwu 中原文物* (3):16-22.
- Liu Jingwen 刘景文 1985. Jilin Tongfa Liao Mu 吉林同发辽墓 [Liao Tomb at Tongfa, Jilin]. *Kaogu 考古* (7).

- Liu Junyu & Sun Gang 刘俊玉 & 孙刚 1999. Liaoning Zhangwu Xian Dongpingcun Liaomu Fajue Jianbao 辽宁彰武县东平村辽墓发掘简报 [a Brief Report on Excavations of Liao Tombs at Dongping Village, Zhangwu, Liaoning]. *Beifang wenwu 北方文物* (1):31-34.
- Liu Kedong 刘可栋 1982. Shilun Woguo Gudai De Mantouyao 试论我国古代的馒头窑 [a Tentative Discuss on Mantou Kiln of Ancient China]. In *Zhongguo Gutaoci Lunwenji*, edited by e. Zhongguo guisuan yan xuehui. Beijing.
- Liu Laixue 2004. *Neimenggu Kaogu Wushi Nian 内蒙古考古五十年 [Fifty Years of Archaeology in Inner Mongolia]*. Edited by L. Liu. Hohhot: Neimenggu zizhi qu wenwu kaogu yanjiusuo.
- Liu Lan & Zhao Chunhua 柳岚 & 邵春华 1986. Jilin Shuangliao Xian Gaolige Liaomu Qun 吉林双辽县高力戈辽墓 [Liao Tombs at Gaolige, Shuangliao, Jilin]. *Kaogu 考古* (2).
- Liu Lanhua 刘兰华 1995a. Longquanwu Ciyao De Wenhua Tezheng Jiqi Yaozhi Xingzhi Chutan 龙泉务瓷窑的文化特征及其窑址性质初探 [a Preliminary Discussion of the Cultural Features and Attributes of the Longquanwu Kiln]. *Wenwu shijie 文物世界* (4):57-62.
- 1995b. Longquanwu Yaozhi De Yaoju Jiqi Zhuangshao Gongyi 龙泉务窑址的窑具及其装烧工艺 [Kiln Instruments and Loading Technique of Longquanwu Kiln Site]. *Wenwu tiandi 文物天地* (6).
- Liu li & Liu qian 刘颀 & 刘谦 1999. Liaomu Fenqi Shilun 辽墓分期试论 [a Tentative Discuss on Chronology of Liao Tombs]. *Liaoning gongcheng jishu daxue xuebao (shehui kexue ban) 辽宁工程技术大学学报(社会科学版)* (03).
- Liu Li 刘莉 1994a. Liao Sancai Gailun 辽三彩概论 [General Discuss on Liao Three-Color Glazed Ceramics]. *Songzhou xuekan 松州学刊* (6).
- 1994b. Lingyuan Jinnian Chutu De Jijian Taociqi Jiqi Xiangguan Wenti De Tantaolun 凌源近年出土的几件陶瓷器及其相关问题的探讨 [Discuss on a Group of Ceramics Unearthed from Lingyuan and Some Related Questions]. *Liaohai wenwu xuekan 辽海文物学刊* (2):104-109.
- Liu Liancheng et al. 刘连成等 1994. Haidian Qu Yangfangdian Liao Mu 海淀区羊坊店辽墓 [Liao Tomb at Yangfangdian, Haidian]. In *Zhongguo Kaogu Xue Nianjian (1992 Nian) 中国考古学年鉴(1992年)*. Beijing: Wenwu chubanshe.
- Liu Liangyou 刘良佑 1989. Wudai Yu Liao Guo De Taoci Jianding 五代与辽国的陶瓷鉴定 [Discriminations between Liao Ceramics and Five Dynasties' Ceramics]. *Gugong wenwu yuekan 故宫文物月刊* 7 (2).
- Liu Liping 刘丽萍 1996. Heilongjiang Sheng Liao Jin Kaogu Faxian Yu Yanjiu 黑龙江省辽金考古发现与研究 [Discoveries and Studies on Liao and Jin Archaeology of Heilongjiang Province]. *Neimenggu shehui kexue(ren wen ban) 内蒙古社会科学(人文版)* (02).
- Liu miao 刘淼 2003. Song Liao Jin Yuan Jiaocang Ciqi Yanjiu 宋辽金元窖藏瓷器研究 [Study on Ceramics from Song, Liao, Jin and Yuan Hoards], Nankai university 南开大学, Tianjin.

- Liu Pu 刘朴 1999. Hebei Chengde Xian Fangshengou Faxian Yizuo Liaomu 河北承德县房深沟发现一座辽墓 [a Liao Tomb Found at Fangshengou, Chengde, Hebei]. *Beifang wenwu 北方文物* (01):35-36.
- 2002. Hebei Sheng Chengde Xian Faxian Liaodai Jiaocang 河北省承德县发现辽代窖藏 [a Liao Hoard Found at Chengde, Hebei]. *Beifang wenwu 北方文物* (03).
- Liu Pujiang 刘浦江 1999. *Liao Jin Shi Lun 辽金史论 [Discuss on History of Liao and Jin]*. Shenyang: Liaoning daxue chubanshe 辽宁大学出版社.
- 2003. *Ershi Shiji Liao Jin Shi Lunzhu Mulu 二十世纪辽金史论著目录 [Bibliography on Liao and Jin History of 20th Century]*. Edited by Liu Pujiang 刘浦江. Shanghai: Shanghai cishu chubanshe 上海辞书出版社.
- Liu Qian 刘谦 1956. Liaoning Faku Yemaotai Liaomu 辽宁法库叶茂台辽墓 [Liao Tombs at Yemaotai, Faku]. *Kaogu tongxun 考古通讯* (3).
- 1984. Liaoning Jinzhoushi Zhangkangcun Liaomu Fajue Baogao 辽宁锦州市张扛村辽墓发掘报告[a Report of the Excavations of Liao Tombs at Zhangkangcun, Jinzhou, Liaoning]. *Kaogu 考古* (11):990-1002.
- Liu Ren 刘任 1987. Hebei Zhangbei Xian Qingli Yizuo Liaodai Bihua Mu 河北张北县清理一座辽代壁画墓 [Liao Tomb with Mural Paintings at Zhangbei, Hebei]. *Kaogu 考古* (1).
- Liu Shujuan 刘淑娟 1988. Liaodai Tongjing De Fenlei Yu Fenqi 辽代铜镜的分类与分期 [Classification and Chronology of Liao Bronze Mirrors]. *Liaohai wenwu xuekan 辽海文物学刊* (2).
- 1997. *Liaodai Tongjing Yanjiu 辽代铜镜研究 [Study of Bronze Mirrors of Liao Dynasty]*. Shenyang: Shenyang chubanshe.
- Liu Suxia 刘素侠 1987. Cong Jiguanhu Xingzhi De Yanbian Kan Qidan Minzu Shenghuo Fangshi De Bianhua 从“鸡冠壶”形制的演变看契丹民族生活方式的变化 [the Changes of Khitan's Life Style from the View of the Evolution on the Form of Bag-Shaped Pilgrim Flasks]. *Songzhou xuekan 松州学刊* (4-5).
- 1995. Cong Chifeng Diqu Qidan Kaogu Kan Liaodai Taoci Ye De Fazhan 从赤峰地区契丹考古看辽代陶瓷业的发展 [Development of Liao Ceramic Manufacturing from the View of the Khitan Archaeology in Chifeng Region]. *Songzhou xuekan 松州学刊* (3-4).
- 1997a. Chifeng Diqu Liao Dai Muzang De Fenbu Jiqi Tedian 赤峰地区辽代墓葬的分布及其特点 [Distribution and Characteristic of Liao Tombs in Chifeng Region]. In *Zhongguo Kaogu Jicheng (Dongbei Juan) 中国考古集成 (东北卷)*. Beijing: Beijing chubanshe.
- 1997b. Cong Liaomu Bihua Kan Qidan Ren De Shehui Shenghuo 从辽墓壁画看契丹人的社会生活 [Social Life of Khitan People from the View of Mural Paintings of Liao Tombs]. *Shehui kexue jikan 社会科学辑刊* (03).

- 1998a. Chifeng Diqu Liao Dai Ciqi Gaishuo 赤峰地区辽代瓷器概说 [Overview on Liao Ceramics of Chifeng Region]. *Neimenggu wenwu kaogu* 内蒙古文物考古 (02).
- 1998b. Chifeng Diqu Liao Dai Ciyao Yizhi De Faxian Yu Yanjiu 赤峰地区辽代瓷窑遗址的发现与研究 [Discovery and Study on Liao Ceramic Kiln Sites in Chifeng Region]. *Zhaowuda mengzu shizhuan xuebao* 昭乌达蒙族师专学报 (3).
- Liu Tao 刘涛 2004. Song Liao Jin Taoci Yanjiu Zhong De Ruogan Wenti 宋辽金陶瓷研究中的若干问题 [Several Aspects on the Study of Song, Liao and Jin Ceramics]. *Zhongguo wenwu bao* 中国文物报.
- Liu Tao 刘涛, and 深圳市文物管理委员会 Shenzhen shi wenwu guanli weiyuanhui 2004. *Song Liao Jin Jinian Ciqi 宋辽金纪年瓷器 [Dated Ceramics of the Song, Liao and Jin Periods]*. Beijing: Wenwu chubanshe 文物出版社.
- Liu Wei 刘未 2004. Liao Mu Lun Gang: Yi Muzang Xingzhi Wei Zhongxin 辽墓论纲——以墓葬形制为中心 [Outline of Discuss on Liao Tombs from the View of Typology of Liao Tombs]. Thesis, M Phil, Peking University, 2004, Department of Archaeology, Beijing.
- Liu Weidong 刘伟东 2004. Chifeng Shi Yuanbaoshan Qu Dayingzi Liaomu 赤峰市元宝山区大营子辽墓 [Liao Tomb at Dayingzi, Yuanbaoshan, Chifeng]. *Neimenggu wenwu kaogu* 内蒙古文物考古 (02).
- Liu Xinyuan 刘新园 1980. Jingdezhen Hutianyao Geqi Dianxing Wan Lei De Zaoxing Tezheng Jiqi Chengyin Kao 景德镇湖田窑各期典型碗类的造型特征及其成因考. *Wenwu* 文物 (11).
- Liu Xiuzhong 刘秀中 1996. Qian Tan Tang Sancai Yu Song Liao Jin Sancai 浅谈唐三彩与宋、辽、金三彩 [Brief Discuss on Tang Three-Color Glazed Wares and Song, Liao and Jin Ones]. *Zhongguo wenwu bao* 中国文物报, Jan.14.
- Liu Y. 2000. Basic Characteristics of Ding Kiln Porcelain and the Identification of Kilns Firing Imitation Ding Kiln Porcelain. *China Archaeology and Art Digest* (3(4)):59-64.
- Liu Yaohui 刘耀辉 1999. Beijing Liao Mu Chutan 北京辽墓初探 [Preliminary Discuss on Liao Tombs in Beijing]. *Beijing wenbo* 北京文博 (4).
- Liu Yi 刘毅 2005. Song Liao Gaoli Ren Xin Zhuizi Tanxi 宋辽高丽人形注子探析 [a Tentative Analysis on Human Shaped Ewer of Song and Liao Dyansty]. *Zhongyuan wenwu* 中原文物 (06).
- Liu Yiquan 刘义全 1990. Mentougou Xinqiaojie Liaomu 门头沟新桥街辽墓 [Liao Tomb at Xinqiao Street of Mentougou]. *Beijing kaogu xinxi* 北京考古信息 (1).
- Liu Yong 刘勇 1996. Jilin Lياهو Hujiatun Liaodai Bihua Mu 吉林梨树胡家屯辽代壁画墓 [Liao Tombs with Mural Paintings at Hujiatun, Lishu, Jilin]. *Bowuguan yanjiu* 博物馆研究 (3).

- Liu Zhenhua 刘振华 1973. Nongan Wanjin Taji Chutu Wenwu 农安万金塔基出土文物 [Relics Unearthed from the Foundations of Wanjin Pagoda at Nongan] *Wenwu 文物* (8):48-54.
- Liu Zhenqun 刘振群 1982. Yaolu De Gaijin He Woguo Gutaoci Fazhan De Guanxi 窑炉的改造和我国古陶瓷发展的关系 [Transform of the Kilns and Its Relationship with the Development of Chinese Ancient Ceramics]. In *Zhongguo Gutaoci Lunwenji*, edited by e. Zhongguo guisuanyan xuehui. Beijing.
- Liu Zhi'an 刘志安 2000. Liaodai Sancai Siyu Pen 辽代三彩四鱼盆 [Liao Three-Colored Basin with Four Fishes Designs]. *Neimenggu wenwu kaogu 内蒙古文物考古* (2):87.
- Liu Zilong & Wang Ye 刘子龙 &王焯 1998. Pingquan Xian Bowuguan Cang Liao Ci 平泉县博物馆藏辽瓷 [Liao Ceramics Collections in Pingquan Museum]. *Wenwu chunqiu 文物春秋* (01):74,78.
- Liu Zilong et al. 刘子龙等 1998. Hebei Pingquan Xian Bowuguan Cang Liao Dai Jiguanhu 河北平泉县博物馆藏辽代鸡冠壶 [Liao Bag-Shaped Pilgrim Flask Collected in Pingquan Museum of Hebei]. *Kaogu 考古* (6).
- Lou Yudong 楼宇栋 1994. Liao Chengguo Gongzhu Mu Chutu De Yu Qi He Shuijing Qi 辽陈国公主墓出土的玉器和水晶器 [Jade Wares and Crystal Wares Unearthed from the Liao Tomb of Princess of Chen State]. *Zhongguo wenhua 中国文化* (02).
- Lovell, Hin-cheung 1953. *Illustrated Catalogue of Ting Yao and Related White Wares Section 4 in the Percival David Foundation of Chinese Art*. London: Aries/Gemini.
- Lovell, Hin-cheung, Hong Lin, and Hebei Sheng (China). *Wen wu guan li chu*. 1968. *Investigation of the Ting Ware Kiln-Site at Jian Ci Cun, Hebei, Chinese Translations No. 4*. London: Victoria & Albert Museum.
- Lu Jianguo 卢建国 1980. Tongchuanshi Huangpuzhen Chutu Tangdai Jinhua Yinwan 铜川市黄堡窑镇出土唐代金花银碗 [a Tang Gilt Silver Bowl Has Been Discovered at Huangpuzhen, Tongchuan]. *Wenwu 文物* (7):96.
- Lu Jing 路菁 2003. *Liao Dai Taoci 辽代陶瓷 [Liao Pottery and Porcelain]*. Shenyang: Liaoning huabao chubanshe
- Lu Qi 鲁琪 1978. Beijing Mentougouqu Longquanwu Faxian Liaodai Ciyao 北京门头沟区龙泉务发现辽代瓷窑 [a Liao Kiln Site Has Been Discovered at Longquanwu in the Mentougou District, Beijing]. *Wenwu 文物* (5):26-32.
- Lu Sixian & Du Chengwu 陆思贤&杜承武 1983. Chayouqianqi Haoqianying Di Liu Hao Liao Mu Qingli Jianbao 察右前旗豪欠营第六号辽墓清理简报[a Brief Report of Clearing up of Liao Tomb at Haoqianying, Chayouqianqi]. *Wenwu 文物* (9):1-8.
- Lü Xueming & Zhu Da 吕学明&朱达 2003. Lingyuan Majiagou Liao Mu Qingli Jianbao 凌源马家沟辽墓清理简报 [Brief Report on the Clearing up of a Liao Tomb at Majigou, Linyuan]. In

- Liaoning Kaogu Wenji 辽宁考古文集 [Collection of Archaeological Papers on Liaoning]*, edited by Liaoningsheng wenwu kaogu yanjiusuo. Shenyang: Liaoning minzu chubanshe.
- Lü Xueming 吕学明 1997. Jianping Tangjiayhangyi Liaomu Qingli Jianbao 建平唐家杖子辽墓清理简报 [a Brief Report on Clearing up of Liao Tomb at Kangjiazhangzi, Jianping]. *Liaohai wenwu xuekan 辽海文物学刊* (01):24-29.
- Lu Yidong 鲁亦冬 1994. *Zhongguo Song Liao Jin Xia Jingji Shi 中国宋辽金夏经济史 [Economic History of Chinese Song, Liao, Jin and Xixia Dynasty]*, Bai Juan Ben *Zhongguo Quan Shi* : 52. Beijing: Renmin chubanshe.
- Lu Yinghong et al. 卢迎红等 2001. Liao Ci Zaoxing Jiqi Zhuangshi Yishu: Jian Beijing Liao Jin Cheng Yuan Bowuguan Cangpin Jieshao 辽瓷造型及其装饰艺术—兼北京辽金城垣博物馆藏品介绍 [Introduction on Formative and Decorative Art of Liao Ceramics and Also on the Collections of Museum Liao and Jin's City Wall Sites in Beijing]. *Beijing wenbo 北京文博* (4):66-72.
- Luo Chunzheng 罗春政 2002. *Liao Dai Hui Hua Yu Bi Hua 辽代绘画与壁画 [Paintings and Murals of Liao Dynasty]*. 1st edition ed. Shenyang: Liaoning huabao chubanshe.
- Luo Shiping 罗世平 1999. Liaomu Bihua Shidu 辽墓壁画试读 [a Tentative Understanding of the Murals in Liao Tombs]. *Wenwu 文物* (01):76-8.
- 2004. Liao Mu Bihua De Faxian Yu Yanjiu 辽墓壁画的发现与研究 [Discovery and Study on the Mural Paintings from Liao Tombs]. In *Yishu Shi Yanjiu 艺术史研究*. Guangzhou: Zhongshan daxue chubanshe.
- Ma Cheng & Li Jianmin 2005. *Zhongguo Ming Yao Di Tu 中国名窑地图 [the Map of Chinese Famous Ancient Ceramic Kiln]*. Di 1 ban. ed. Shanghai: Shanghai wenhua chubanshe.
- Ma Hong 马洪 1987. Tongyu Xian Faxian San Zuo Liao Mu 通榆县发现三座辽墓 [Three Liao Tombs Found at Tongyu County]. *Jilin wenwu 吉林文物* (23).
- Ma Honglu 马洪路 1982. Faku Yemaotai Shijiu Hao Liaomu Fajue Jianbao 法库叶茂台十九号辽墓发掘简报 [a Brief Report on Excavation of Tomb at Yemaotai, Faku]. *Liaoning wenwu 辽宁文物* (总 3).
- Ma Lin 马林 1988. Fula'erji Liaodai Muzang Kao 富拉尔基辽代墓葬考 [Discuss on Liao Tombs at Fula'erji] *Lilun guancha 理论观察* (05).
- Ma Liqing & Zhang Jingming 马利清 & 张景明 2000. Shixi Liaodai Shehui Jingji Fazhan Zai Wenxian Shiwu Zhong De Tixian 试析辽代社会经济发展在文献、实物中的体现 [a Tentative Discuss on the Social and Economic Development of Liao Dynasty from the View of Literatural and Objective Materials]. *Neimenggu daxue xuebao (renwen shehui kexue ban) 内蒙古大学学报(人文.社会科学版)* (02).

- Ma Liqing 马利清 1998. Qidan Yu Bohai Guanxi Tanyuan 契丹与渤海关系探源 [Discuss on the Origin of the Relationship between Khitan and Bohai]. *Neimenggu shehui kexue (han wen bao)* 内蒙古社会科学(汉文版) (05).
- Ma Qingpeng & Zhao Zhihou 马清鹏 &赵志厚 1997. Hebei Luanpingxian Yinwogou Liaomu 河北滦平县银窝沟辽墓 [Liao Tomb at Yinwogou, Luanping, Hebei]. *Beifang wenwu 北方文物* (3):47-49.
- Ma Sha 马沙 2000. Liaodai Zhici Ye De Chansheng Jiqi Lishi Gongxian 辽代制瓷业的产生及其历史贡献 [Origin and the Historical Contribution of Liao Ceramics Manufacturing]. *Wenwu shijie 文物世界* (02).
- 2001. Lun Liaodai Jiguanhu De Fenqi Yanbian Jiqi Xiangguan Wenti 论辽代鸡冠壶的分期演变及其相关问题 [Discuss on the Phased Evolution of Liao Bag-Shaped Pilgrim Flasks and Some Related Questions]. *Beifang wenwu 北方文物* (01):29-35.
- Ma Wenkuan 马文宽 1994a. *Cong Kaogu Ziliao Kan Zhongguo Tang Song Shijie Yu Yisilan Shijie De Wenhua Jiaoliu 从考古资料看中国唐宋世界与伊斯兰世界的文化交流 [the Cultural Communication between Chinese Tangsong and Islamic World from the Perspective of Archaeological Materials.]*. Beijing: Kexue chubanshe.
- 1994b. Liao Chenguo Gongzhu Mu Chutu Yisilan Zanhua Tong Pen Kao 辽陈国公主墓出土伊斯兰鏤花铜盆考 [Study of the Islamic Chased Basin from Liao Princess Chen's Tomb]. In *Neimenggu Wenwu Kaogu Wenji 内蒙古文物考古文集 [Papers on Cultural Relics and Archaeology in Inner Mongolia(1)]*. Beijing: Zhongguo dabaiké quanshu chubanshe.
- 1994c. Liaomu Liaota Chutu De Yisilan Boli Jiantan Liao Yu Yisilan Shijie De Guanxi 遼墓遼塔出土的伊斯蘭玻璃：兼談遼與伊斯蘭世界的關係 [Islamic Glass from Liao Tombs and Liao Pagodas : on the Relationship between Liao and the World of Islam]. *Kaogu* (8):736-43.
- 2002. Faku Yemaotai Zaoqi Liaomu Chutu De Yisilan Boli Tiaowei Fangpan 法库叶茂台早期辽墓出土的伊斯兰玻璃调味方盘 [Islamic Rectangular Glass Plate from the Early Liao Tomb at Yemaotai , Faku]. *Zhongguo lishi wenwu 中国历史文物* (03):46-8.
- Ma Xigui 马希桂 1983. Beijing Liao Mu He Taji Chutu De Baici Yaoshu Wenti Shangque 北京辽墓和塔基出土的白瓷窑属问题商榷 [Discuss on the Attribution of Liao White Porcelains Unearthed from Liao Tombs and Foundations of Pagodas in Beijing]. *Beijing wenwu yu kaogu 北京文物与考古* (1).
- 1989. Jianguo Yilai Beijing Liaomu He Taji Chutu Baici Jianshu 建国以来北京辽墓和塔基出土白瓷简述 [Summary on the White Porcelains Unearthed from Liao Tombs and Foundations of Pagodas in Beijing since 1949]. In *Shoudu Bowuguan Guoqing Sishi Zhounian Wenji 首都博物馆国庆四十周年文集*. Beijing Zhongguo minjian wenyi chubanshe.

- 2000. Beijing Liao Mu He Taji Chutu Baici Yaoshu Wenti De Shangque 北京辽墓和塔基出土白瓷窑属问题的商榷 [Discuss on the Attribution of Liao White Porcelains Unearthed from Liao Tombs and Foundations of Pagodas in Beijing]. In *Beijing Kaogu Jicheng 北京考古集成*. Beijing: Beijing shi wenwu yanjiusuo.
- Medley, Margaret 1972. *Metalwork and Chinese Ceramics*. London: Percival David Foundation of Chinese Art.
- 1980. *Illustrated Catalogue of Ting and Allied Wares*. London: Percival David Foundation of Chinese Art.
- 1981. *Tang Pottery and Porcelain*. London: Faber.
- Mei Pengyun 梅鹏云 2001. Tianjin Jixian Mileyuan Cun Liao Mu 天津蓟县弥勒院村辽墓 [Liao Tomb at Mileyuan Village of Ji County in Tianjin]. *Wenwu chunqiu 文物春秋* (06).
- Meng Jianren & Piao Chunyue 孟建仁 & 朴春月 1997. Keyouzhongqi Daiqintala Liao Mu Qingli Jianbao 科右中旗代钦塔拉辽墓清理简报 [Brief Report on the Clearing of a Liao Tomb at Daiqintala, Keyou Central Banner]. In *Neimenggu Wenwu Kaogu Wenji 内蒙古文物考古文集 [Essays on the Archaeology of Cultural Relics in Inner Mongolia]*, edited by Wei Jian. Beijing: Zhongguo da baike quanshu chubanshe.
- Meng Jianren & Qian Yucheng 孟建仁 & 钱玉成 1994. Tuquan Xian Xishan Cun Liao Mu 突泉县西山村辽墓 [Liao Tombs at Xishan Village of Tuquan County]. In *Neimenggu Wenwu Kaogu Wenji 内蒙古文物考古文集*, edited by Neimenggu wenwu kaogu yanjiusuo. Beijing: Zhongguo dabaike quanshu chubanshe.
- Meng Jingxin 蒙景新 1994. Neimenggu Wenniute Qi Faxia Liaodai Jiguanhu 内蒙古翁牛特旗发现辽代鸡冠壶 [Liao Bag-Shaped Pilgrim Flasks Found in Wengniute Banner, Inner Mongolia]. *Beifang wenwu 北方文物* (01).
- Meng Qingshan 孟庆山 1998. Qidan De Wenhua Fazhan Ji Dui Zhongguo Dongbei Bu Wenhua Fazhan De Lishi Zuoyong 契丹的文化发展及对中国东北部文化发展的历史作用 [Cultural Development of Khitan and Its Historical Contribution for the Cultural Development of Northeast China]. *Liaoning daxue xuebao (zhexue shehui kexue ban) 辽宁大学学报(哲学社会科学版)* (05).
- 2005. Liaodai Kuangchan Ziyuan De Kaifa Yu Liyong 辽代矿产资源的开发与利用 [Development and Use of the Mineral Source in Liao Dynasty]. *Liaoning gongcheng jishu daxue xuebao (shehui kexue ban) 辽宁工程技术大学学报(社会科学版)* (05).
- Meng Zhaoyong & Chen Ping 孟昭勇 & 陈萍 1990. Qian'an Shanglu Chutu Liaodai Ciqi 迁安上芦出土辽代瓷器 [Liao Ceramics Unearthed from Shanglu, Qian'an]. *Wenwu chunqiu 文物春秋* (1):88-91.
- Meng Zhidong 孟志东 1995. *Yunnan Qidan Houyi Yanjiu 云南契丹后裔研究 [Study on the Descendants of Khitan in Yunnan]*. Beijing: Zhongguo shehui kexue chubanshe.

- Miao Jianmin & Lu Shoulin 1990. Thermoluminescence Authenticity Assay of Tang Dynasty Tri-Color Pottery. *Wen wu bao hu yu kao gu ke xue* 2 (2):27-32.
- Miao Jiasheng et al. 苗家生等 2001. Fuxin Faxian Liao Dai Daxing Gu Mu Qun: Jiu Zuo Xiao Shi Hou Zu Muzang Xiangji Chutu 阜新发现辽代大型古墓群:九座萧氏后族墓葬相继出土 [Lagde Scale of Liao Tombs Found in Fuxin with Nine Tombs of Xiao Family Found in Succession]. *Guangming ribao* 光明日报.
- Miao Runhua 苗润华 1988. Neimenggu Balin Youqi Hutulu Liaomu 内蒙古巴林右旗虎吐路辽墓 [Liao Tomb at Hutulu, Balin Right Banner, Inner Mongolia]. *Beifang wenwu* 北方文物 (03).
- 1994. Balin Youqi Bayanhushao Liao Mu He Yuandai Yizhi 巴林右旗巴彦琥绍辽墓和元代遗址 [Liao Tombs and Yuan Sites Found at Bayanhushao, Balin Right Banner]. *Neimenggu wenwu kaogu* 内蒙古文物考古 (01).
- 1995. Neimenggu Balin Youqi Chagangwusu Liao Mu 内蒙古巴林右旗查干勿苏辽墓 [Liao Tombs at Chaganwusu, Balin Right Banner, Inner Mongolia]. *Liaohai wenwu xuekan* 辽海文物学刊 (02):20-24.
- 1996. Neimenggu Balin Youqi You'ai Liaomu 内蒙古巴林右旗友爱辽墓 [Liao Tomb at You'ai, Balin Right Banner, Inner Mongolia]. *Wenwu* 文物 (11).
- Michaelson, Carol 1999. *Gilded Dragons: Buried Treasures from China's Golden Ages*. London: British Museum Press.
- Mikami Tsugio 三上次男 1955. So Ryo Bunka No Fukaku 宋辽文化の風格 [Characteristics of Song and Liao Culture]. In *Sekai Toji Zenshu:Sou, Ryo* 世界陶磁全集(宋辽篇)[*Catalogue of the World's Ceramics: Song Liao*]. Tokyo: Kawade Shobo 河出書房.
- 1968. Persian Pottery and Chinese Ceramics. *Museum* (212):4-12.
- 1973. Ryonei・Ganguantun Kama to Sono Seikaku : Chusei Manchuria Toji Ni Kansuru Ichi Kosatsu 遼寧・缸官屯窯とその性格 : 中世マンチュリア陶磁に関する一考察 [Ganguantun Kiln in Liaoning Province and Its Characteristics]. In *Touyou Toji* 東洋陶磁. Touyou toji gakkai 東洋陶磁学会.
- 1981a. Bokai Ryo No Toji 渤海、遼、金、元の陶磁器生産とその歴史的背景. In *Sekai Toji Zenshu:Ryo, Kin, Gen* 世界陶磁全集:遼金元 [Catalogue of the World's Ceramics: Liao Jin Yuan], edited by Goto Shigeki. Tokyo: Shogakukan 小學館.
- 1981b. Bokai Ryo No Toji 渤海・遼の陶磁 [Ceramics of Liao and Bohai]. Edited by Goto Shigeki 後藤茂樹 ed. Vol. 13, *Sekai Toji Zenshu:Ryo, Kin, Gen* 世界陶磁全集:遼金元 [Catalogue of the World's Ceramics: Liao Jin Yuan]. Tokyo: Shogakukan 小學館.
- 1981c. Ryo, Kin, Gen 遼、金、元 [Liao, Jin, Yuan]. Vol. 13, *Sekai Toji Zenshu* [Catalogue of the World's Ceramics]. Tokyo: Shogakukan.

- Min Xuanhua 闵宣化 1956. *Dong Menggu Liaodai Jiucheng Tanhao Ji 东蒙古辽代旧城探考记* [Records on the Investigations of Liao Old City Sites in Eastern Mongolia]. Feng Chengjun 冯承钧, ed. Beijing: Zhonghua shuju.
- Mino Yutaka et al., and Wilson Patricia 1971. Some Aspects of the Development of Liao Dynasty Ceramics. *Oriental Art* (Autumn, 1971 , vol.17 , no.3):245-251.
- Mino Yutaka et al. 袁豐, China House Gallery, and China Institute in America 1973. *Ceramics in the Liao Dynasty, North and South of the Great Wall*. New York: China House Gallery : China Institute in America.
- Mino Yutaka et al. 袁豐, Patricia Wilson, and Royal Ontario Museum. 1973. *An Index to Chinese Ceramic Kiln Sites from the Six Dynasties to the Present*. Toronto: Royal Ontario Museum.
- Mino Yutaka 袁豐 1973. Liao Dynasty Ceramics at China House Gallery, New York. *Connoisseur* (CL XXXIII).
- 1974a. *Pre-Sung Dynasty Chinese Stonewares in the Royal Ontario Museum*. Toronto: Royal Ontario Museum.
- 1974b. Ryojodai No Tojiki 遼時代の陶磁器 [Liao Ceramics]. *陶説* (250 ~ 251).
- 1975. Brief Survey of Early Chinese Glazed Wares. *Artibus Asiae* 37 (1/2):39-52.
- 1980. *Freedom of Clay and Brush through Seven Centuries in Northern China: Tz'u-Chou Type Wares, 960-1600 A.D* . . Indianapolis; Bloomington: Indianapolis Museum of Art; Indiana University Press.
- 1981. *Freedom of Clay and Brush through Seven Centuries in Northern China: Tzu-Chou Type Wares, 960-1600 A.D*. New York.
- Miyake Soetsu 三宅宗悦 1940. Manshu-Koku Nekka-Sho Yohkuji Fukin No Iseki Ni Tsuite 滿洲國熱河省葉柏壽の遺跡ヒフソテ [a Paper on the Site near Yebaishou in Jehol Province, Manchuria]. *Kokogaku Zasshi 考古学杂志* (vol.32 no.1):27-28.
- Miyake Soetsu 三宅宗悦 1940. Keikanko Wo Shutsudoseru Saisho No Kofun Nitsuite 鷄冠壺を出土せる最初の古墳について [on Bag-Shaped Pilgrim Flasks and the First Ancient Tomb Which Derived from] *国立中央博物館時報* (5).
- Mo Rennan 莫任南 1991. Wudai Song Liao Jin Shiqi De Zhong Xi Lulu Jiaotong 五代宋辽金时期的中西陆路交通 [Overland Communication between China and the West in Song, Liao, Jin and Five Dynasties]. *Xibei shidi 西北史地* (3).
- Mok, Kar-Leung Harold 1985. *The Study of Liao Ceramics*. Thesis, M Phil , University of Hong Kong, 1985, University of Hong Kong, Hong Kong.
- 1989a. Ceramic Flasks of the Liao Dynasty. *Oriental Art* (Autumn):150-62.

- Mok, Kar-Leung Harold 莫家良 1987. Liaodai Taoci Zhong De Long Yu Xing Zhu 辽代陶瓷中的龙鱼形注 [Dragon-Fish Shaped Ewer of Liao Ceramics]. *Liaohai wenwu xuekan 辽海文物学刊* (2).
- 1989b. Liaodai Taoqi Zhong De Pinanghu 辽代陶器中的皮囊壶 [Ceramic Flasks of the Liao Dynasty]. *Zhongguo wenwu shijie 中国文物世界 (香港)* (44).
- 2004. Ticai Yu Wenhua: Liao Dai Muzang Bihua 题材與文化——辽代墓葬壁畫 [Motif and Culture: Mural Painting from Liao Tombs]. In *Song Mo Feng Hua :Qidan Yishu Yu Wenhua 松漠風華：契丹藝術與文化*. Hong Kong: Xianggang zhongwen daxue wenwu guan 香港中文大学文物馆.
- Mori Osamu 森修 1937. Nekka Kinshu - Ryo-Sho Hakken Toki Ko 熱河錦州兩省发现陶器考 [a Note on Ceramics Discovered in the Provinces of Jehol and Jinzhou]. *Kokogaku Zasshi 考古学杂志* 27 (3):184-187.
- Mote, Frederick W. 1999. *Imperial China, 900-1800*. Cambridge, Mass.: Harvard University Press.
- Mu Yi 木易 1993. Liaomu Chutu De Jinshu Mianju Wangluo Ji Xiangguan Wenti 辽墓出土的金属面具、网络及相关问题 [Metal Facemasks and Netting Excavated from Liao Tombs and Other Questions]. *Beifang wenwu 北方文物* (01):28-34.
- Mullie, Jos, Chengjun Feng, Victor Goloubew, and Georges Maspéro 2004. *Dong Menggu Liao Dai Jiu Cheng Tan Kao Ji : Wai 2 Zhong*. Beijing di 1 ban. ed, *Shi Jie Han Xue Lun Cong*. Beijing Shi: Zhonghua shu ju.
- Mullie, Joseph 1922. Les Anciennes Vilies De L'empire Des Grands Leao Au Royaume Mongol De Barin on the Ancient Cities of the Great Liao Empire in the Mongol Kingdom of Barin. *T'oung Pao* (21):106-231.
- Nakano Toru 中野徹 1981. Ryo Kin Gen Toji No Monyo 遼金元陶磁の文様 [Designs on Ceramics of Liao, Jin and Yuan Dynasty]. In *Sekai Toji Zenshu Vol. 13 世界陶磁全集遼金元* [Catalogue of the World's Ceramics: Liao Jin Yuan], edited by Goto Shigeki 後藤茂樹 ed. Tokyo: Shogakukan 小學館.
- Nantong bowuguan 南通博物馆 1974. Jiangsu Nantong Shi Faxian Liao Ci Pinanghu 江苏南通市发现辽瓷皮囊壶 [Liao Ceramic Bag-Shaped Pilgrim Flask Found in Nantong, Jiangsu]. *Wenwu 文物* (2).
- Neimenggu wenwu kaogu yanjiusuo et al. 内蒙古文物考古研究所等 1994. Ningchengxian Yuejia Zhangzi Liao Xiaofujun Mu Qingli Ji 宁城县岳家杖子辽萧府君墓清理记 [Records on Clearing up of Liao Tomb of Xiao Fujun at Yuejiazhangzi, Ningcheng]. In *Neimenggu Wenwu Kaogu Wenji 内蒙古文物考古文集*, edited by Neimenggu wenwu kaogu yanjiusuo. Beijing: Zhongguo dabaike quanshu chubanshe.
- 1997. Helinge'er Nanyuanzi Muzang Qingli Jianbao 和林格尔南园子墓葬清理简报 [a Brief Report on Clearing up of Liao Tombs at Nanyuanzi, Helinge'er]. In *Neimenggu*

Wenwu Kaogu Wenji 内蒙古文物考古文集, edited by Neimenggu wenwu kaogu yanjiusuo. Beijing: Zhongguo dabaiké quanshu chubanshe.

——— 2002. Baiyinhanshan Liaodai Hanshi Jiazhu Mudi Fajue Baogao 白音罕山辽代韩氏家族墓地发掘报告 [Report on the Excavation of Han's Family Cemetery of Liao Dynasty in Bai Yin Han Mountain]. *Neimenggu wenwu kaogu* (2):19-42.

Neimenggu wenwu kaogu yanjiusuo et al. 内蒙古文物考古研究所等, and Zhelimumeng bowuguan 哲里木盟博物馆 1993. *Liao Chenguo Gongzhu Mu* 辽陈国公主墓 [Liao Tomb of the Princess of Chen State]. Edited by Neimenggu wenwu kaogu yanjiusuo & Zhelimumeng bowuguan 内蒙古文物考古研究所 & 哲里木盟博物馆. Beijing: Wenwu chubanshe.

Neimenggu wenwu kaogu yanjiusuo 内蒙古文物考古研究所 1994a. Balin Youqi Aobaoenge'er Liao Mu 巴林右旗敖包恩格尔辽墓 [Liao Tombs at Aobao'enge'er, Baolin Right Banner]. In *Neimenggu Wenwu Kaogu Wenji* 内蒙古文物考古文集, edited by Neimenggu wenwu kaogu yanjiusuo. Beijing: Zhongguo dabaiké quanshu chubanshe.

——— 1994b. Liao Shangjing Chengzhi Kancha Baogao 辽上京城址勘察报告 [Survey and Excavation of the Liao Shangjing City Site]. In *Neimenggu Wenwu Kaogu Wenji* 内蒙古文物考古文集 [Essays on the Archaeology of Cultural Relics in Inner Mongolia], edited by Li Yiyou & Wei Jian. Beijing: Zhongguo da baike quanshu chubanshe.

——— 1997. Keyou Zhongqi Shuanglonggang Liao Mu 科右中旗双龙岗辽墓 [Liao Tomb at Shuanglonggang, Keyou Right Banner]. *Neimenggu wenwu kaogu* 内蒙古文物考古 (1):60-67.

——— 1999. Guanyu Yangshan Deng Wuchu Liaomu Bihua Zonghe Fenxi 关于羊山等五处辽墓壁画综合分析 [Analysis on Yangshan and Other Four Liao Tomb's Murals]. *Neimenggu wenwu kaogu* 内蒙古文物考古 (01):98-104.

——— 2004. Neimenggu Tongliao Shi Tu'erji Shan Liao Dai Muzang 内蒙古通辽市吐尔基山辽代墓葬 [the Liao-Period Grave at Tuerji Hill, Tongliao City, Inner Mongolia]. *Kaogu* 考古 (7):50-53.

Neimenggu wenwu kaogu yanjiusuo 内蒙古文物考古研究所, and Qi Xiaoguang et al. 1996. Liao Yelu Yuzhi Mu Fajue Jianbao 辽耶律羽之墓发掘报告 [Brief Report on the Excavation of the Liao Tomb of Yelu Yuzhi]. *Wenwu* (1):4-32.

Neimenggu zhaomeng wenwu gongzuozhan 内蒙古昭盟文物工作站 1984. *Liao Dai Bihua* 辽代壁画 [Mural Paintings of Liao Dynasty] Shanghai: Shanghai renmin meishu chubanshe.

Neimenggu zizhi qu wenhuating & Zhongguo lishi bowuguan 内蒙古自治区文化厅 & 中国历史博物馆 2002. *Qidan Wangchao: Neimenggu Liao Dai Wenwu Jinghua* 契丹王朝-内蒙古辽代文物精华 [Khitans Dynasty: Liao Archaeological Treasures from Inner Mongolia]. Edited by Neimenggu zizhi qu wenhuating & Zhongguo lishi bowuguan 内蒙古自治区文化厅 & 中国历史博物馆. Beijing: Zhongguo zangxue chubanshe.

- Neimenggu zizhiqiu wenwu gongzuodui et al. 内蒙古自治区文物工作队等 1979. Neimenggu Wenwu Kaogu Sanshi Nian 内蒙古文物考古工作三十年 [Thirty Years' Archaeological Works in Inner Mongolia]. In *Wenwu Kaogu Gongzuo Sanshi Nian 文物考古工作三十年*, edited by Wenwu bianji weiyuanhui. Beijing: Wenwu chubanshe.
- Neimenggu zizhiqiu wenwu gongzuodui 内蒙古自治区文物工作队 1961. Helingerxian Tuchengzi Gumu Fajue Jianjie 和林格尔县土城子辽墓发掘简介 [Introduction to the Excavations at Tuchengzi, Helinger County]. *Wenwu 文物* (9):30-33.
- 1963. *Neimenggu Chutu Wenwu Xuanji 内蒙古出土文物选集 [Selected Cultural Relics Unearthed in Inner Mongolia]*. Beijing: Wenwu chubanshe.
- 1977. Neimenggu zizhiqiu Wenwu Kaogu Gongzuo De Zhongda Chengguo 内蒙古自治区文物考古工作的重大成果 [the Great Achievement of Archaeological Work Carried out in the Inner Mongolia Autonomous Region]. *Wenwu 文物* (5):1-6.
- Neiqiu xian wenbaosuo 内丘县文保所 1987. Hebei Neiqiu Xian Xingyao Diaocha Jianbao 河北内丘县邢窑调查简报 [a Brief Report on Investigations of Xing Kiln Site at Neiqiu, Hebei]. *Wenwu 文物* (9).
- Niigata kenritsu kindai bijutsukan 新潟县立近代美术馆 1999. *Tokotei Kara No Okurimou 唐皇帝からの贈り物 [Gifts of the Tang Emperors: Hidden Treasures from Famen Temple]*. Edited by b. 新. Niigata kenritsu kindai. Niigata 新潟: Niigata kenritsu kindai bijutsukan.
- Palmgren, Nils, Walter Steger, and Nils Sundius 1963. *Sung Sherds*. Stockholm: Almqvist & Wiksell.
- Pan Xingrong 潘行荣 1965. Neimenggu Keyouqianqi Baixintun Gumu Gucheng De Diaocha 内蒙古古科右前旗白辛屯古墓古城的调查 [Investigations of the Old City and the Tombs at Baixintunm Keyouqianqi, Inner Mongolia]. *Kaogu 考古* (7):374-376.
- Pang Zhiguo 庞志国 1992. Da'an Shi Tiexiqi Liaodai Muzang 大安市铁西村辽代墓群 [Liao Tombs at Tiexi District, Da'an City]. In *Zhongguo Kaogu Xue Nianjian(1991 Nian) 中国考古学年鉴 (1991 年)*. Beijing: Wenwu chubanshe.
- 1993. Dui Da'an Shi Tiexi Liaomu De Fajue 对大安市铁西辽墓的发掘 [Excavations at Liao Tombs at Tiexi, Da'an]. *Bowuguan yanjiu 博物馆研究* (2).
- Pei Yaojun 裴耀军 1996. Kangping Zhangjiayao Yi Hao Liaomu 康平张家窑 1 号辽墓 [Liao Tomb at Zhangjiayao, Kangping]. *Liaohai wenwu xuekan 辽海文物学刊* (01):57-62.
- Peng Ke 彭柯 1992. Mengdong Liaoxi Diqu Liaomu Fenqi Yu Fenqu Chutan 蒙东、辽西地区辽墓分期与分区初探 [Preliminary Discuss on Division and Chronology of Liao Tombs in the Region of West of Liaoning and East of Inner Mongolia]. In *Wenwu Yanjiu Lunji 文物研究论集*. Shanghai: Shanghai guji chubanshe.
- Peng Shanguo & Guo Zhizhong 彭善国&郭治中 2000. Chifeng Gangwayao De Zhicigongju Yaoju Ji Xiangguan Wenti 赤峰缸瓦窑的制瓷工具、窑具及相关问题 [Kiln Instruments and

- Related Questions of Gangwayaocun Kiln Site in Chifeng]. *Beifang wenwu 北方文物* (4):41-45.
- Peng Shanguo 彭善国 1998a. Liao Yelü Yuzhi Mu Chutu Ciqi Shi Tan 辽耶律羽之墓出土瓷器试探 [a Tentative Discuss on Ceramics Unearthed from Liao Tomb of Yelü Yuzhi]. *Bowuguan yanjiu 博物馆研究* (1).
- 1998b. Tan Liao Yelü Yuzhi Mu Chutu De Jijian Ciqi 谈辽耶律羽之墓出土的几件瓷器 [on Several Ceramics Unearthed from Liao Tomb of Yelü Yuzhi]. *Wenwu chunqiu 文物春秋* (1):72-73.
- 2003a. Liao Dai Qidan Guizu Sangzang Xisu De Kaogu Xue Guancha 辽代契丹贵族丧葬习俗的考古学观察 [Archaeological View on the Burial Custom of Khitan Aristocracy of Liao Dynasty]. In *Bianjiang Kaogu Yanjiu 边疆考古研究*. Beijing: Kexue chubanshe.
- 2003b. *Liao Dai Taoci De Kaogu Xue Yanjiu 辽代陶瓷的考古学研究 [an Archaeological Research on Ceramics of the Liao Dynasty]*. Changchun: Jilin daxue chubanshe 吉林大学出版社.
- 2003c. Suowei Liaodai Youxia Heihua Qi De Niandai Wenti 所谓辽代釉下黑花器的年代问题 [Dating Problem on So Called Underglazed White Painted Wares of Liao Dynasty]. *Wenwu chunqiu 文物春秋* (05):25-28.
- 2006. Ershi Shiji Liaodai Kaogu De Faxian Yu Yanjiu 二十世纪辽代考古的发现与研究 [Discoveries and Studies of Liao Archaeology of the 20th Century]. *Neimenggu wenwu kaogu 内蒙古文物考古* (01).
- Piao Zhongguo & Zhang Guoqing 朴忠国 & 张国庆 1997. *Liaodai Qidan Xisu Shi 辽代契丹习俗史 [Custom History of Khitan in Liao Dynasty]*. Shenyang: Liaoning minzu chubanshe.
- Qi Dongfang & Zhang Jing 齐东方&张静 1994. Tang Dai Jinyinqi Yu Xifang Wenhua De Guanxi 唐代金银器皿与西方文化的關係 [Relationship between Tang Metalwork and Western Culture]. *Kaogu xuebao* (2):173-89.
- Qi Dongfang 齐东方 1992. Lijiayingzi Chutu De Shute Yinqi Yu Caoyuan Zhilu 李家营子出土的粟特银器与草原之路 [Sogdian Silver Ware Excavated in Lijiayingzi and the Grassland Silk Road]. *Beijing daxue xuebao 北京大學學報(哲學社會科學版)* (2):35-41.
- 1999. *Tang Dai Jin Yin Qi Yanjiu 唐代金银器研究 [Research on Tang Gold and Silver]*. Beijing: Zhongguo shehui kexue chubanshe.
- Qi Honghao et al. 齐鸿浩等 1992. Liao Sancai Pusa Xiang 辽三彩菩萨像 [Three-Color Glazed Bodhisattva Ceramic Statue of Liao Dynasty]. *Beijing wenwu bao 北京文物报* (11).
- 1994. Beijing Chutu Liao Baici Yu Longquanwu Yao Guanxi Chu Tan 北京出土辽白瓷与龙泉窑关系初探 [Preliminary Discuss on the Relationship between Longquanwu White Wares and the Ones Unearthed from Beijing Region]. In *Beijing Wenwu Yu Kaogu 北京文物与考古*. Beijing: Beijing shi wenwu yanjiusuo.

- Qi Xia & Qiao Youmei 漆侠 & 乔幼梅 1994. *Liao Xia Jin Jingji Shi 辽夏金经济史 [Economic History of Liao, Xia and Jin]*. Shijiazhuang: Hebei daxue chubanshe.
- Qi Xiaoguang et al. 齐晓光等 1998. Neimenggu Chifeng Baoshan Liao Bihuamu Fajue Jianbao 内蒙古赤峰宝山辽壁画墓发掘简报 [Brief Report on the Wall Paintings from a Liao Tomb in Baoshan, Chifeng, Inner Mongolia]. *Wenwu* (1):73-95.
- Qi Xiaoguang 齐晓光 1987. Neimenggu Kulun Qi Qi Ba Hao Liao Mu 内蒙古库伦旗七、八号辽墓 [Liao Tomb and at Kulun Banner, Inner Mongolia] *Wenwu 文物* (7).
- 1988. Aluke'er Qin Qi Chai Damu Liao Mu 阿鲁科尔沁旗柴达木辽墓 [Liao Tomb at Chaidamu of Aluke'erqin Banner]. In *Zhongguo Kaoguxue Nianjian(1986 Nian) 中国考古学年鉴 (1986 年)*. Beijing Wenwu chubanshe.
- Qi Xiaoguang 齐晓光 1991. Ningcheng Xian Xiaotangtugou Liao Mu 宁城县小塘土沟辽墓 [a Liao Tomb at Xiaotangtugou, Ningcheng County]. *Neimenggu wenwu kaogu 内蒙古文物考古* (01):68-71.
- Qi Xiaoguang 齐晓光 1995. Phoenix in Der Steppe: Das Kammergrab Des Qidan-Prinzen Yelu Yuzhi in Der Inneren Mongolei Phoenix in the Steppe: The Tomb of the Khitan Prince Yelu Yuzhi in Inner Mongolia. *Antike Welt* (26):437--43.
- 1997a. Jinnianlai Aluke'erqin Qi Liaodai Muzang De Zhongyao Faxian 近年来阿鲁科尔沁旗辽代墓葬的重要发现 [Some Important Discoveries of Liao Tombs at Aluke'erqin Banner in the Past Few Years]. *Neimenggu wenwu kaogu 内蒙古文物考古* (01):7-13.
- 1997b. Yelü Yuzhi Mu Han Yuwai Wenhua Yinsu Zhi Jin Yin Qi 耶律羽之墓含域外文化因素之金银器 [Gold and Silver with Foreign Cultural Elements from Yelu Yuzhi's Tomb]. In *Neimenggu Wenwu Kaogu Wenji (2) 内蒙古文物考古文集(第2辑) [Papers on Cultural Relics and Archaeology in Inner Mongolia (2)]*, edited by Wei Jian. Beijing: Zhongguo dabaiké quanshu chubanshe.
- Qi Xin & Liu Jingyi 齐心 & 刘精义 1980. Beijingshi Fangshanxian Beizhengcun Liaota Qinglijì 北京市房山县北郑村辽塔清理记 [a Record of the Cleaning up of a Liao Pagoda at Beizhengcun, Fangshanxian, Beijing]. *Kaogu 考古* (2):147-158.
- Qian Boquan 钱伯泉 1999. Yelü Dashi Xi Xing Luxian Yanjiu 耶律大石西行路线研究 [Study on the Westbound Routes of Yelü Dashi]. *Xiyu yanjiu 西域研究* (3).
- Qiao Liang & Yang Jing 乔梁 & 杨晶 1993. Liao Tao Ci Qi De Fen Qi Yanjiu 辽陶瓷器的分期研究 [Chronological Study on Liao Ceramics]. In *Qingguo Ji: Jilin Daxue Kaogu Zhuanye Chengli Ershi Zhounian Kaogu Lunwen Ji 青果集——吉林大学考古专业成立二十周年考古论文集*, edited by Jilin daxue kaogu xi. Beijing: Zhishi chubanshe.
- 2001. Heilongjiang Xibu De Liaodai Muzang 黑龙江省西部的辽代墓葬 [Liao Tombs in the West of Heilongjiang]. *Beifang wenwu 北方文物* (04):44-50.

- Qin Dashu 秦大树 2001. Baiyou Tihua Zhuangshi De Chanshem Fazhan Ji Xiangguan Wenti 白釉剔花装饰的产生、发展及相关问题 [Origin, Development and Related Questions on the Sgraffito Decoration of White Glazed Wares]. *Wenwu 文物* (11).
- Qinggongyebu taoci gongye kexue yanjiusuo, 轻工业部陶瓷工业研究所 1983. *Zhongguo De Ciqi 中国的瓷器* [Pottery and Porcelain of China]. Beijing: Qinggongye chubanshe.
- Qiqiha'er shi wenwu guanlizhan 齐齐哈尔市文物管理站 2003. Qiqiha'er Fula'erji Liao Dai Zhuanshi Mu 齐齐哈尔富拉尔基辽代砖室墓 [Liao Tomb with Brick Chamber at Fula'erji of Qiqiha'er]. *Beifang wenwu 北方文物* (3):35-37.
- Qiu Guobin 邱国彬 1998. Neimenggu Aohanqi Pijianggou Yi Er Hao Liaomu 内蒙古敖汉旗皮匠沟 1、2 号辽墓 [Liao Tomb and at Pijianggou, Aohan Banner, Inner Mongolia]. *Wenwu 文物* 9:46-52,63.
- Qu Shi 曲石 2001. Liang Song Liao Jin Yu Qi 两宋辽金玉器 [Jades in Song, Liao and Jin Dynasties]. *Zhongyuan wenwu 中原文物* (06):48-61.
- Rague, B. von 1963. Zur Liao-Dreifarben-Keramik. *Berliner Museen* (NF XIII).
- Ran Wanli 冉万里 2002. Liaodai Xianglu De Chubu Yanjiu 辽代香炉的初步研究 [Preliminary Study on Ceramic Incense Burner of Liao Dynasty]. *Wenbo 文博* (04):62-71.
- Rawson, J., M. Tite, and M. J. Hughes 1989. The Export of Tang Sancai Wares: Some Recent Research. *Transactions of the Oriental Ceramic Society* (1987-88):39-61.
- Rawson, Jessica 1989. Chinese Silver and Its Influence on Porcelain Development. In *Cross-Craft and Cross-Cultural Interactions in Ceramics*, edited by P. E. McGovern and M. D. Notis. Easton, Pennsylvania: American Ceramic Society.
- Reckel, Johannes 1989. Das Kitan-Volk Im Spiegel Seiner Graeber the (Material Culture) of the Khitan People as Mirrored in the Findings from Their Tombs. *Zentralasiatische Studien des Seminars fuer Sprach- und Kulturwissenschaft Zentralasiens der Universitaet Bonn* (22):18-141.
- 1995. Bohai: Geschichte Und Kultur Eines Mandschurisch-Koreanischen Koenigreiches Der Tang-Zeit Bohai: History and Culture of a Manchu-Korean Kindgom of the Tang Period. Wiesbaden: Harrassowitz.
- Reischauer, Edwin O. 1939. Japanese Archeological Work on the Asiatic Continent in 1937 and 1938. *Harvard Journal of Asiatic Studies* 4 (1):87-98.
- Ren Chongyue 任崇岳 1983. Lun Liaodai Qidanzu Dui Hanzu Wenhua De Xishou He Jicheng 论辽代契丹族对汉族文化的吸收和继承 [Discuss on the Absorption and Inheriting of Khitan from Han Culture]. *Zhongzhou xuekan 中州学刊* (03).

- 1984. Lue Lun Liaocha Yu Wudai De Guanxi 略论辽朝与五代的关係 [Preliminary Discuss on the Relationship between Liao and Five Dynasties]. *Shehui kexue jikan 社会科学辑刊* (4).
- Ren Zhilu & Meng Yaohu 任志录 & 孟耀虎 1998. Hunyuan Gu Ciyao You Zhongyao Faxian 浑源古瓷窑有重要发现 [Important Discovery of Ancient Kiln Sites in Hunyuan]. *Zhongguo wenwu bao 中国文物报*, Feb.25.
- Ren Zhilu 任志录 2000. Shanxi Hunyuanyao De Kaogu Chengjiu 山西浑源窑的考古成就 [Archaeological Achivement of Huanyuan Kiln in Shanxi]. *Wenwu shijie 文物世界* (4):42-44.
- Riddell, Sheila 1979. *Dated Chinese Antiquities: 600- 1650*. London: Faber.
- Rorex, Robert Albright 1984. Some Liao Tomb Murals and Images of Nomads in Chinese Paintings of the Wen-Chi Story. *Artibus Asiae* 45 (2/3):174-198.
- Rossabi, Morris 1983. *China among Equals: The Middle Kingdom and Its Neighbors, 10th-14th Centuries*. Edited by R. Morris. Berkeley: University of California Press.
- Rosser-Owen, Mariam, University of Oxford., and Ashmolean Museum. 2001. *A Web-Based Teaching Course on Islamic Ceramics*. Oxford: University of Oxford ; Ashmolean Museum.
- Rui Chuanming 芮傳明 1998. *Zhongguo Yu Zhongya Wenhua Jiaoliu Shi 中國與中亞文化交流志 [Records on the Cultural Exchange between China and Central Asia]*. Shanghai: Shanghai renmin chubanshe.
- Saito Kikutaro 齋藤菊太郎 1938. Ryo Sansai No Hanashi 遼三彩の話 [Liao Three-Color Glazed Ceramics]. *Chawan 茶わん* (88).
- 1941. Rinto Shoken--Ryo Sansai No Kakunin to Koyoseki No Hakken 林东所见——遼三彩の確認と古窯址の發現 [Liao Ceramics and the Ancient Kiln Sites Found in Lindong]. *Toji 陶磁* (12:4).
- 1942. Keikanko 雞冠壺 [Bag-Shaped Pilgrim Flasks]. *Mingei 民藝* (4:11).
- 1954. Ryo No Chotsubo 遼代の長壺 (1 ~ 2) [Chicken-Leg Vases of Liao Dynasty: ,]. *陶説* (11 ~ 12).
- 1973. Keiryō Shutsudo No Tojihen No Kaimei: Juichi Seiki No Hokuso Kanyo, Teiyo Oyobi Rintoyo Hakuji to Koraiseiji 慶陵出土の陶磁片の解明 : 十一世紀の北宋官窯,定窯及び林東窯白磁と高麗青磁 [Decipherment of Porcelain Fragments, Excavated from Three Tombs of Liao Emperors]. In *Toyo Toji 東洋陶磁 [Oriental Ceramic]*. Tokyo: ToyoTojiGakkai 東洋陶磁学会.
- Sato Masahiko 佐藤雅彦 1977. So No Biakuji 宋の白磁 [Song White Wares]. In *Sekai Toji Zenshu Vol. 12*, edited by e. Goto Shigeki. Tokyo.

- Schulten, Caroline 2000. *Ancient Chinese Mirrors and Their Legacies in the Tang (Ad 618-906), Liao (Ad 907-1125) and Song (Ad 960-1279) Periods, Ph.D. Dissertation*. Oxford: University of Oxford.
- Shaanxi lishi bowuguan et al., and Beijing daxue kaogu wenbo xueyuan Beida zhendan gudai wenming yanjiu zhongxin 2003. *Hua Wu Datang Chun: Hejiacun Yibao Jingcui Selected Treasures from Hejia Village Tang Hoard*. Beijing: Wenwu chubanshe.
- Shaanxisheng bowuguan wenguanghui geweihui xiezuozu 陕西省博物馆文馆会革委会写作小组 1972. Xian Nanjiao Hejiacun Faxian Tangdai Jiaocang Wenwu 西安南郊何家村发现唐代窖藏文物 [Relics from a Tang Cache Have Been Discovered at Hejiacun on the Outskirts South of Xian]. *Wenwu 文物* (1):30-42.
- Shaanxisheng wenwu guanli weiyuanhui 陕西省文物管理委员会 1966. Shaanxisheng Sanyuanxian Shuangshengcun Sui Li He Mu Qingli Jianbao 陕西省三原县双盛村隋李和墓清理简报 [a Brief Report of the Clearing up of the Sui Tomb of Li He at Shuangshengcun, Sanyuan County, Shaanxi Province]. *Wenwu 文物* (1):27-42.
- Shang Xiaobo 尚晓波 1989. Liaoning Sheng Chaoyang Shi Faxian Liaodai Gongxian Mu 辽宁省朝阳市发现辽代龚祥墓 [Liao Tomb of Gong Xiang Found at Chaoyang, Liaoning]. *Beifang wenwu 北方文物* (04):28-31.
- Shanghai bowuguan 上海博物馆 2000. *Caoyuan Guibao: Neimenggu Wenwu Kaogu Jingpin 草原瑰宝: 内蒙古文物考古精品 [Treasures on Grassland: Archaeological Finds from the Inner Mongolia Autonomous Region]*. Edited by S. M. 上海博物馆. Shanghai: Shanghai shuhua chubanshe.
- Shanghai renmin meishu chubanshe 1986. *Ryōdai tōji 辽代陶磁 [Liao Ceramics]*. Edited by S. R. m. Chubanshe. Vol. 17, *ChūGoku tōji Zenshu 中国陶瓷全集 [Corpus of Chinese Ceramics]*. Kyoto: Bi no Bi 美乃美.
- Shanghai renmin meishu chubanshe ed. 上海人民美術出版社 1981. Teyo 定窑 [Ding Ware]. In *Chugoku Toji Zenshu Vol.9 中国陶磁全集,定窑 [Corpus of Chinese Ceramics,Ding Ware]*, edited by T. Shokai jinmin bijutsu shuupansha. Kyoto: Binobi 美乃美.
- 1983. To Sansai 唐三彩 [Tang Three-Colored Ware]. In *Chugoku Toji Zenshu Vol.7,to Sansai 中国陶磁全集,唐三彩 [Corpus of Chinese Ceramics,Tang Three-Colored Ware]*. Kyoto.
- Shanxi sheng wenwuju & Zhongguo lishi bowuguan 1991. *Yingxian Muta Liaodai Micang 应县木塔辽代秘藏 [Liao Hidden Relics in the Ying County Timber Pagoda]*. Beijing: Wenwu chubanshe.
- Shanxi sheng wenwuju 山西省文物局 1991. *Shanxi Fojiao Caisu 山西佛教彩塑 [Buddhist Sculpture of Shanxi Province]*. Beijing;Hong Kong: Chinese Buddhist Association 中國佛教協會;Hong Kong Po Lin Monastery 香港寶蓮禪寺.

- Shanxi Yungang guji baoyangsuo 山西云岗古迹保养所 1958. Datong Jiaoqu Qingciyao Faxian Gudai Yiwu 大同郊区青瓷窑发现古代遗物 [Some Relics Have Been Discovered at Qingciyao on the Outskirts of Datong]. *Wenwu 文物* (6):72.
- Shanxisheng wenwu guanli weiyuanhui 山西省文物管理委员会 1960. Shanxi Datong Jiaoqu Wuzuo Liao Bihuamu 山西大同市郊五座辽壁画墓 [the Five Liao Tombs with Mural Paintings on the Outskirts of Datong, Shanxi]. *Kaogu 考古* (10):37-42.
- Shao Guotian ed. 邵国田 2004. *Aohan Wenwu Jinghua 敖汉文物精华 [Selected Cultural Relics from Aohan Banner]*. Edited by Shao Guotian 邵国田. Hulunbei'er: Neimenggu wenhua chubanshe.
- Shao Guotian et al. 邵国田等 1999a. Aohanqi Lamagou Liaodai Bihua Mu 敖汉旗喇嘛沟辽代壁画墓 [Liao Mural Tomb at Lamagou, Aohan Banner]. *Neimenggu wenwu kaogu 内蒙古文物考古* (01):90-97.
- 1999b. Aohanqi Xiawanzi Liaomu Qingli Jianbao 敖汉旗下湾子辽墓清理简报 [a Brief Report on the Excavation of Liao Tombs at Xianwanzi, Aohan Banner]. *Neimenggu wenwu kaogu 内蒙古文物考古* (1):67-84.
- 1999c. Aohanqi Yangshang Yi Zhi Sanhao Liaomu Qingli Jianbao 敖汉旗羊山1—3号辽墓清理简报 [a Brief Report on Clearing up of Liao Tombs to at Yangshan, Aohan Banner] *Neimenggu wenwu kaogu 内蒙古文物考古* (01):1-38, 43.
- Shao Guotian 邵国田 1978. Aohanqi Baitazi Liaomu 敖汉旗白塔寺子辽墓 [a Liao Tomb at Baitazi, Aohan Banner]. *Kaogu 考古* (2):119-121.
- 1980. Aohanqi Nailingaocun Chutu De Jijian Liaodai Taociqi 敖汉旗乃林皋村出土的几件辽代陶瓷器 [Several Pieces of Liao Ceramics Unearthed at Nailingaocun, Aohanqi]. *Wenwu 文物* (7):94-95.
- 1984. Neimenggu Zhaowudameng Aohanqi Beisanjia Liaomu 内蒙古昭乌达盟敖汉旗北三家辽墓 [the Liao Tombs at Beisanjia, Aohanqi, Zhaowudameng, Inner Mongolia]. *Kaogu 考古* (11):1003-1011, 970.
- 1987. Neimenggu Aohan Qi Shazigou Dahenggou Liao Mu 内蒙古敖汉旗沙子沟、大横沟辽墓 [Liao Tombs at Shazigou and Dahenggou of Aohan Banner, Inner Mongolia]. *Kaogu 考古* (10):889-904.
- 1988. Neimenggu Aohan Qi Faxian Huren Qishi Liaoci Xiang 内蒙古敖汉旗发现胡人骑狮辽瓷像 [a Statue of Foreigner Riding on Lion Found at Aohan Banner, Inner Mongolia]. *Beifang wenwu 北方文物* (02).
- 1994. Aohanqi Niangniang Miao Liaodai Bihua Mu 敖汉旗娘娘庙辽代壁画墓 [Liao Tomb with Mural Painting at Niangniang Temple in Aohan Banner]. *Neimenggu wenwu kaogu 内蒙古文物考古* (01).

- 1995. Aohanqi Chutu Liang Jian Liao Dai Tongjing 敖汉旗出土两件辽代铜镜 [Two Bronze Mirrors Found at Aohan Banner]. *Wenwu* 文物 (05).
- 1997. Aohanqi Chutu De Heiyou Anhua Hulu Ping 敖汉旗出土的黑釉暗花葫芦瓶 [Black Glazed Gourd Shaped Vase with Concealed Floral Designs]. *Neimenggu wenwu kaogu* 内蒙古文物考古 (1):41.
- Shao Qinglong & Yan Ruiyuan 邵清隆&嚴瑞源 1995. *Anma Wenhua: Zhongguo Gudai Beifang Youmu Minzu 鞍馬文化：中國古代北方遊牧民族* [Life on the Saddle : History of Nomadic Culture in Northern China]. Hong Kong: Hong Kong Regional Council 香港區域市政局.
- Shao Qinglong 邵清隆 1981. Liaodai Baici Foxiang 辽代白瓷佛像 [a Liao White Porcelain Buddha]. *Neimenggu wenwu kaogu* 内蒙古文物考古 (5):143-144.
- Shen Hsueh-man, Asia Society. Museum, Museum für Ostasiatische Kunst der Stadt Köln, and Museum Rietberg 2006. *Gilded Splendor : Treasures of China's Liao Empire (907-1125)*. New York; Milano: Asia Society; 5 Continents.
- Shen Liangyou 申友良 2001. Lun Liaodai Zhongjing Diqu De Kaifa 论辽代中京地区的开发 [Discuss on the Exploitation of the Region of Liao Central Capital]. *Liaoning daxue xuebao (zhexue sheihui kexue ban)* 辽宁大学学报(哲学社会科学版) (06).
- Shenyangshi wenguanhui et al. 沈阳市文管会等 1986. Shenyang Tawan Wugou Jingguan Sheli Ta Tagong Qingli Baogao 沈阳塔湾无垢净光舍利塔塔宫清理报告 [Report on Clearing up of the Underground Chamber of Liao Pagoda of Wugoujingguan at Tawan, Shenyang]. *Liaohai wenwu xuekan* 辽海文物学刊 (2).
- Shi Yongshi 石永士 1986. Hebei Yixian Jingjuesi Sheli Taji Digong Qingli Ji 河北易县净觉寺舍利塔基地宫清理记 [Records on the Clearing up of the Foundation and Underground Chamber of Liao Pagoda of Jingjue Temple at Yi County, Hebei]. *Wenwu* 文物 (9):76-80.
- Shimada Masao 島田正郎 1952. *Ryodai Shakaishi Kenkyo 遼代社會史研究* [Study on Social History of Liao]. Kyoto: Sanwashoten 三和書店.
- 1964. *Liao De She Hui Yu Wen Hua*. Taipei Shi: Cung-guo wen hua xue yuan.
- 1973. *Ryosie No Kenkyu 遼史への研究* [Study on Liao History]. 1 vols. Tokyo.
- Shimada Sadahiko 島田禎彦 1940. *从考古学上所见的热河* [Jehol Seen from the View of Archaeology]. 1940: 满洲国民生部刊.
- 1941. Keikanko 鷄冠壺 [Bag-Shaped Pilgrim Flasks]. *Chawan* 茶碗 (121).
- Shiruku Rodo-gaku Kenkyu Senta 1999. *Islamic and Chinese Ceramics of Central Asia, Silk Roadology ; 7*. Nara: The Nara International Foundation.

- Shoudu bowuguan 首都博物馆 1991. *Shoudu Bowuguan Cang Ci Xuan 首都博物馆藏瓷选* [Selected Ceramic Collections of Capital Museum]. Edited by 首. Shoudu bowuguan. Beijing: Wenwu chubanshe.
- Shu Fen 舒焚 1984. *Liao Shi Gao 辽史稿 [Liao History]*. Wuhan: Hubei renmin chubanshe
- Shui Jisheng 水既生 1980. Shanxi Gudai Taoci Zhuangshi Jifa Jiqi Yingyong 山西古代陶瓷装饰技法及其应用 [Decorative Technique and Its Application on Ancient Ceramics of Shangxi]. *Hebei taoci 河北陶瓷* (4).
- 1983. Shanxi Gu Yaozhi Zhong Suo Jian Heiyou Ti Ke Hua Ciqi 山西古窑址中所见黑釉剔刻花瓷器 [White Glazed Ceramics with Sgraffito Designs Seen from Ancient Kiln Sites of Shanxi]. *Jingdezhen taoci 景德镇陶瓷* (1).
- 1987. Shanxi Gudai Yaoju Ji Zhuangshao Fangfa De Chutan 山西古代窑具及装烧方法的初探 [a Preliminary Study on Kiln Instruments and Loading Technique of Ancient Ceramics of Shanxi]. In *Zhongguo Gu Taoci Yanjiu 中国古陶瓷研究*, edited by Zhongguo kexueyuan shanghai guisuan yan yanjiusuo. Beijing: Kexue chubanshe.
- Singer, Felix, and Sonia S. Singer 1963. *Industrial Ceramics*. London: Chapman & Hall.
- Siri Guleng 斯日古楞 2000. Balin Youqi Bowuguan Guancang Liaodai Jiguanhu 巴林右旗博物馆馆藏辽代鸡冠壶 [Liao Bag-Shaped Pilgrim Flasks Collected in Museum of Balin Right Banner]. *Neimenggu wenwu kaogu 内蒙古文物考古* (2):110-13.
- Smith, Robert A. 1997. Borax in Glass - Ancient or Modern?
<http://www.borax.com/pioneer18.html>, <http://www.borax.com/pioneer18.html>.
- So, Jenny F. 2004. *Songmo Fenghua: Qidan Yishu Yu Wenhua 松漠风华: 契丹艺术与文化 [Noble Riders from Pines and Deserts: The Artistic Legacy of the Qidan]*. Edited by J. F. So. Hongkong: Art Museum of the University of Hong Kong 香港中文大学文物馆
- Song Jianhua 宋建华 1994. Liaodai Taoci De Yishu Tese 辽代陶瓷的艺术特色 [Artistic Features of Liao Ceramics]. *Jilin daxue shehui kexue xuebao 吉林大学社会科学学报* (4).
- Song Zhigang 宋志刚 1998. Hebei Zhangjiakou Shi Bowuguan Cang Liaodai Lüyou Gaozu Pan 河北张家口市博物馆馆藏辽代绿釉高足盘 [Green Glazed Dish with Step Foot Collected in Museum of Zhangjiakou in Hebei Province]. *Beifang wenwu 北方文物* (03).
- Sotheby's London 1985. *Chinese Decorative Arts. Liao*. Sotheby's London.
- Spekke, Arnolds 1957. *The Ancient Amber Routes and the Geographical Discovery of the Eastern Baltic*. Stockholm: M . Goppers.
- Standen, Naomi 2007. *Unbounded Loyalty : Frontier Crossings in Liao China*. Honolulu: University of Hawaii Press.
- Steinhardt, Nancy Riva Shatzman 1997. *Liao Architecture*. Honolulu: University of Hawaii Press.

- Steinhardt, Nancy S. 1998. Liao Archaeology: New Frontiers on China's Frontier. *Asian Perspectives* (37, no. 2):224-44.
- Steinhardt, Nancy Shatzman 1994. Liao: An Architectural Tradition in the Making. *Artibus Asiae* 54 (1/2):5-39.
- 1995. Chinese Buddhist Sculpture under the Liao (Free Standing Works in Situ and Selected Examples from Public Collections). Review of Chinese Buddhist Sculpture under the Liao (Free Standing Works in Situ and Selected Examples from Public Collections).(by Gridley, Marilyn Leidig). *The Journal of Asian Studies* 54 (1):191-193.
- Su Bai 宿白 1998. Xuanhua Kaogu San Ti: Xuanhua Gu Jianzhu, Xuanhua Cheng Yange, Xiabali Liao Mu Qun 宣化考古三题——宣化古建筑·宣化城沿革·下八里辽墓群 [Three Aspects on Archaeology in Xunhua: Architecture, Evolution of the City and Liao Tombs Group at Xiabali]. *Wenwu 文物* (01):45-63.
- Su Beihai 苏北海 1986. Xi Liao Wangchao Tongzhi Xia Hasake Caoyuan Jingji Wenhua De Fazhan 西辽王朝统治下哈萨克草原经济文化的发展 [Economic and Cultural Development of Kazakh Steppe under the Rule of Qara-Khitai]. *Xinjiang daxue xuebao 新疆大学学报* (4).
- 1989. Lun Yelü Dashi De Xizheng Ji Tongyi Zhongya (Shang) 论耶律大石的西征及统一中亚(上) [Discuss on the Westbound Moving of Yelü Dashi and the Unity of Central Asia] . *Beifang minzu 北方民族* (2).
- 1990. Lun Yelü Dashi De Xizhengji Tongyi Zhongya (Xia) 论耶律大石的西征及统一中亚(下) [Discuss on the Westbound Moving of Yelü Dashi and the Unity of Central Asia] . *Beifang minzu 北方民族* (1).
- Su Dong 苏东 2002. Neimenggu Chifeng Gangwayao Shaozao De Liao Sancai Qi 内蒙古赤峰缸瓦窑烧造的辽三彩器 [Liao Three-Color Glazed Wares Made by the Gangwayao Kiln Site at Chifeng, Inner Mongolia]. *Zhongguo lishi wenwu 中国历史文物* (3).
- Su He & Xiang Chunsong 苏赫 & 项春松 1987. Chifeng Diqu Liao Dai Lishi Yu Kaogu 赤峰地区辽代历史与考古 [History and Archaeology of Liao Dynasty in Chifeng Region]. *Songzhou xuekan 松州学刊* (4-5).
- Su He 苏赫 1989. Caoyuan Sichou Zhi Lu Yu Liao Dai Zhongxi Jiaotong 草原丝绸之路与辽代中西交通 [Steppe Silk Road and Communication between China and the West in Liao Dynasty]. *Zhaowuda meng mengzu shizhuan xuebao 昭乌达蒙族师专学报* (04).
- Su Ritai 苏日泰 1982. Keyouzhongqi Bazhalaga Liao Mu 科右中旗巴扎拉嘎辽墓 [Liao Tombs at Bazhalaga, Keyouzhongqi]. *Neimenggu wenwu kaogu 内蒙古文物考古* (2):64-68.
- Su Tianjun 苏天钧 1959a. Beijing Diqu Faxian Liao Jin Shidai Wenwu 北京地区发现辽金时代文物 [Liao and Jin Relics Have Been Found in the Beijing Area]. *Wenwu 文物* (10):83.
- 1959b. Beijing Jiaoqu Liaomu Fajue Jianbao 北京郊区辽墓发掘简报 [a Brief Report of the Excavations of Liao Tombs on the Outskirts of Beijing]. *Kaogu 考古* (2):89-93.

- 1959c. Shinian Lai Beijing Shi Suo Faxian De Zhongyao Gudai Muzang He Yizhi 十年来北京市所发现的重要古代墓葬和遗址 [Important Ancient Tombs and Sites Found in the Past Ten Years in Beijing]. *Kaogu* 考古 (3).
- 1964. Shunyxian Liao Jingguang Shelitaji Qingli Jianbao 顺义县辽净光舍利塔基清理简报 [a Brief Report of the Clearing up of the Foundations of the Liao Jingguang Sheli Pagoda at Shunyi County]. *Wenwu* 文物 (8):49-53.
- 1992. Beijing Diqu Liaodai Zhuanshi Mu Xingzhi Yanjiu (Shang Xia) 北京地区辽代砖室墓形制研究 (上下) [Study on Liao Tombs with Brick Chamber in Beijing Region ()]. In *Jinghua Jiushi Cunzheng* 京华旧事存真. Beijing: Beijing guji chubanshe.
- Sugimura Yuzo 杉村勇造 1937. Mujun Daikanton No Koyoseki 抚顺大官屯の古窑址 [an Old Kiln Site at Daguantun, Fushun]. *Manshu shigaku* 满州史学 (vol.1, 1937 no.2):68-69.
- 1974. Ryo No Toji 遼の陶磁 [Ceramics of the Liao Dynasty]. Vol. 40, 陶磁大系 [Ceramics of the Liao Dynasty, Big Series of Ceramics]. Tokyo: Beibiyousha 平凡社.
- Sun Guolong 孙国龙 2005. Chaoyang Chutu Liaozuo Liaomu Bihua Guankui 朝阳出土两座辽墓壁画管窥 [Restricted View on Two Liao Tombs with Mural Paintings Unearthed at Chaoyang]. *Beifang wenwu* 北方文物 (04).
- Sun Guoping et al. 孙国平等 1992. Liaoning Chaoyang Sunjiawan Liao Mu 辽宁朝阳孙家湾辽墓 [Liao Tomb at Sunjiawan, Chaoyang, Liaoning]. *Wenwu* 文物 (6):12-16.
- Sun Ji 孙机 1986. Mojie Deng: Jian Tan Yuqi Xiangguan De Wenti 摩羯灯——兼谈与其相关的问题 [Discuss on Markara Shaped Lamp and Related Questions]. *Wenwu* 文物 (12):74-78.
- 1996a. Jinnian Neimenggu Chutu De Tujue Yu Tujue Shi Jin Yin Qi 近年内蒙古出土的突厥与突厥式金银器 [Recent Finds of Turkic and Turkic-Style Gold and Silver from Inner Mongolia]. In *Zhongguo Shenghuo: Zhongguo Guwenwu Yu Dong Xi Wenhua Jiaoliu De Ruogan Wenti* 中国圣火—中国古文物与东西文化交流的若干问题. Shenyang: Liaoning jiaoyu chubanshe.
- 1996b. *Zhongguo Shenghuo: Zhongguo Guwenwu Yu Dong Xi Wenhua Jiaoliu De Rougan Wenti* 中国圣火—中国古文物与东西文化交流的若干问题 [Chinese Sacred Flame: Several Questions on Chinese Antiques and Exchange between China and the West]. Shenyang: Liaoning jiaoyu chubanshe.
- Sun Jianhua & Zhangyu 孙建华 张郁, and Neimenggu wenwu kaogu yanjiusuo 内蒙古文物考古研究所 1987. Liao Chenguo Gongzhu Fuma Hezang Mu Fajue Jianbao 辽陈国公主驸马合葬墓发掘简报 [a Brief Report on the Excavations of the Joint Tomb of Princess of Chen State and Her Husband of Liao Dynasty]. *Wenwu* 文物 (11):4-24.
- Sun Jianhua 孙建华, and Neimenggu wenwu kaogu yanjiusuo 内蒙古文物考古研究所 2002. Balin Youqi Chuangjingou 5 Hao Liaomu Fajue Jianbao 巴林右旗床金沟 5 号辽墓发掘简报

- 报 [Brief Report on the Liao Tomb Number 5 at Zhuangjingou in Balin Right Banner].
Wenwu 文物 (3):51-64.
- Sun Jie & Liu Junyu 孙杰 & 刘俊玉 1988. Zhangwu Wujiazi Liao Mu Qingli Jianbao 彰武五家子
辽墓清理简报 [a Brief Report on Clearing up of Liao Tomb at Wujiazi, Zhangwu]. *Liaojin
qidan nüzhen shi yanjiu 辽金契丹女真史研究* (1).
- Sun Jie 孙杰等 1989. Zhangwu Liaodai Yiji Zongshu 彰武辽代遗迹综述 [Summary on Liao Sites
in Zhangwu]. *Liaojin qidan nüzhen shi yanjiu 辽金契丹女真史研究* (1).
- Sun Jinji 孙进已 1983. Si Zhi Shi Zhiji Qidan Shehui De Fazhan 四至十世纪契丹社会的发展 [the
Social Development of the Khitan from the 4 Thto 10 Thcenturies]. *Beifang wenwu 北方
文物* (03).
- Sun Min & Sun Lifeng 郭敏 & 孙利峰 1985. Fengman Gumu Qingli Jianbao 丰满古墓清理简报
[a Brief Report on Clearing up of Ancient Tombs at Fengman]. *Baicheng wenbo 白城文博*
(7).
- Sun Qun 孔群 2006. Liaodi Jin Yin Qi Zhong Zhi Xifang Wenhua He Song Wenhua De Yinsu 辽代
金银器中之西方文化和宋文化的因素 [the Factors of Song Culture and Western Culture
in Gold and Silver Wares of Liao Dynasty]. *Neimenggu daxue yishu xueyuan xuebao 内蒙
古大学艺术学院学报* (01).
- Sun Xiufu 孙秀夫 1996. Liaodai Taoci Chutan 辽代陶瓷初探 [a Preliminary Discuss on Liao
Ceramics]. *Chengde minzu shizhuan xuebao 承德民族师专学报* (01).
- Sun Xiuren 孙秀仁 1982. Xin Zhongguo Shiqi Bohai Kaogu De Jinzhan 新中国时期渤海考古的进
展 [Archaeological Progress with Regard to Bohai in New China]. *Heilongjiang wenwu
congkan 黑龙江文物丛刊* (2):8-16.
- Sun Yutie 孙玉铁 1998. Liaoyang Chaoyang Dongwujiazi Wangfengou Liao Mu Qingli Jianbao 辽
宁朝阳东五家子王坟沟辽墓清理简报 [a Brief Report on Clearing up of Liao Tombs at
Wangfengou, Dongwujiazi, Chaoyang, Liaoning]. *Beifang wenwu 北方文物* (1):51-52.
- Sun Zhongran & Zhang Xiujie 孙衷然 & 张秀杰 1988. Neimeng Huolinguole Shi Liaomu Qingli
Jianbao 内蒙霍林郭勒市辽墓清理简报 [a Brief Report on Clearing up of Liao Tombs at
Xilinguole City of Inner Mongoliga]. *Beifang wenwu 北方文物* (02).
- Suo Xiufen 索秀芬 2004. Liao Chenguo Gongzhu Yu Fuma Hezang Mu Wenwu 辽陈国公主与驸
马合葬墓文物 [Cultural Relics Unearthed from the Joint Tomb of Princess of Chen State
and Her Husband]. *Rong bao zhai 荣宝斋* (03).
- Ta La & Yiyou 塔拉&一友 1984. Aohanqi Fanzhangzi Liao Mu 敖汉旗范仗子辽墓 [Liao Tomb at
Fanzhangzi, Aohan Banner]. *Neimenggu wenwu kaogu 内蒙古文物考古* (3):75-79.
- Ta La & Zhang Yaqiang 塔拉 & 张亚强 2004a. Jiekai Muzhu Shenfen Zhimi: Tu'erko Shan Liao
Mu Fajue Jishi 解开墓主身份之谜——吐尔基山辽墓发掘纪实 [Unveiling the Identity of

- the Tomb Occupant: A Record of the Excavation of a Liao Tomb at Tuerji Hill]. *Zhongguo guojia dili 中国国家地理* (9):132-43.
- 2004b. Tu'erji Shan Liao Mu Kaogu Fajue Baohu 吐尔基山辽墓考古发掘保护 [Preservation of Archaeological Excavations of Liao Tombs at Tu'erji Hill]. *Zhongguo wenhua yichan 中国文化遗产* (03).
- Ta La et al. 塔拉等 1997. Ningcheng Xian Gezidong Liaodai Bihua Mu 宁城县鸽子洞辽代壁画墓 [Liao Tomb with Mural Painting at Gezidong, Ningcheng]. In *Neimenggu Wenwu Kaogu Wenji 内蒙古文物考古文集* edited by Neimenggu wenwu kaogu yanjiusuo. Beijing: Zhongguo dabaike quanshu chubanshe.
- Tain Meng 添萌 1981. Jiguanhu Yu Jituitan 鸡冠壶与鸡腿坛 [Bag-Shaped Pilgrim Flasks and Chicken-Leg Vases]. *Qiushi xuekan 求是学刊* (01).
- Takeshima Takuichi 竹島卓一 1944. *Ryo-Kin Jidai No Kenchiku to Sono Butsu zo 遼金時代の建築と其仏像 [Liao-Jin Architecture and Its Buddhist Sculpture]*. Tokyo: Ryo bun shokyoku 龍文書局.
- Takikawa Masajiro & Shimada Masao 滝川 政次郎 & 島田正郎 1944. *Ryoritsu No Kenkyu 遼律の研究 [a Study of the Legal Code of the Liao Dynasty]* Tokyo: Osakayago Shoten 大阪屋号書店.
- Tamura Jitsuzo & Kobayashi Yukio 田村實造&小林行雄 1953. *Tombs and Mural Paintings of Ch'ing-Lung, Liao Imperial Mausoleums of 11th Century Ad in Eastern Mongolia: Detailed Reports of Archaeological Survey Carried out in 1935 and 1939*. Kyoto: Kyoto University.
- Tamura Jitsuzo 田村實造 1964. *Chugoku Seifuku Ocho No Kenkyu 中国征服王朝の研究 [Dynasties of Conquest in China - History of the Liao Dynasty]*. Kyoto: Toyoshi kenkyukai 東洋史研究会.
- 1977a. *Keiryō No Hekiga : Kaiga Shoshoku Toji 慶陵の壁畫 : 絵畫、彫飾、陶磁 [Murals in the Qing Mausoleums: Paintings, Carvings, Ceramics]*. Kyoto: Doshosha 同朋社.
- 1977b. *Ryo No Toji 遼代の陶磁 [Liao Ceramics]*. In *Keriyō No Hekiga 慶陵の壁畫 [Mural Paintings of Qingling]*. Kyoto: Tohosha 同朋社.
- Tan Qixiang ed. 譚其驤主编 1982. *Zhongguo Lishi Ditu Ji (6): Song Liao Jin Shiqi 中国历史地图集(六) : 宋辽金时期 [Chinese Historical Atlas No.6: The Liao Dynasty and Northern Song Dynasty Period, the Jin Dynasty and Southern Song Dynasty Period]*. Edited by Q. Tan. Shanghai: Ditu chubanshe.
- 1986. *Zhongguo Li Shi Da Ci Dian : Liao Xia Jin Yuan Shi 中国历史大辞典 : 辽夏金元史 [Dictionary of Chinese history: History of Liao, Xia, Jin and Yuan Dynasties]*. Di 1 ban. ed. Shanghai: Shanghai cishu chubanshe.
- 1996. *Zhongguo Lishi Ditu Ji (6): Song Liao Jin Shiqi 中国历史地图集(六) : 宋辽金时期 [the Historical Atlas of China(6): The Liao Dynasty and Northern Song Dynasty Period, the*

- Jin Dynasty and Southern Song Dynasty Period*]. Vol. 6, *Zhongguo Lishi Ditu Ji [the Historical Atlas of China]*. Beijing: Zhongguo Ditu Chubanshe.
- Tang Cailan 唐彩兰 2005. *Liao Shangjing Wenwu Xieying 辽上京文物撷英 [the Museum of Liaoshangjing Quintessence of the Historical Relic]*. Edited by Tang Cailan 唐彩兰. Huhehaote: Yuanfang chubanshe.
- Tang Xiaoxuan 唐小轩 1997. Guancang Liao San Cai Ji Xiangguan Wenti De Tantaoyao 馆藏辽三彩及相关问题的探讨 [Museum Collections of Liao Three-Color Glazed Wares and Related Questions]. *Bowuguan yanjiu 博物馆研究* (2).
- Tang Yuju 唐裕菊 1992. Xinle Yizhi Faxian Liaodai Muzang 新乐遗址发现辽代墓葬 [Liao Tomb Found at Xinle Site]. *Shenyang wenwu 沈阳文物* (1).
- Tang Yunming 唐云明 1973. Hebei Qianan Shanglucun Liao Han Xiang Mu 河北迁安上芦村辽韩相墓 [the Liao Tomb of Han Xiang at Shanglucun, Qianan, Hebei]. *Kaogu 考古* (5):276-278.
- Tao Jingshen 陶晋生 1988. *Two Sons of Heaven : Studies in Sung-Liao Relations*. Tucson: University of Arizona Press.
- 1991. *The Perilous Frontier: Nomadic Empires and China*. Review of *The Perilous Frontier: Nomadic Empires and China*.
- Barfield, Thomas J. *The American Historical Review* 96 (4):1258.
- Tao Min 陶敏 2003. Longhua Xian Changgoumen Liao Mu 隆化县厂沟门辽墓 [Liao Tomb at Changgoumen, Longhua]. *Wenwu chunqiu 文物春秋* (03):50-51.
- Tao Zongye & Li Wei 陶宗冶&李维 1994. Hebei Xuanhua Dengjiatai Liao Mu 河北宣化邓家台辽墓 [Liao Tomb at Dengjiatai, Xuanhua, Hebei]. *Kaogu 考古* (8).
- Tao Zongye 陶宗冶 1991. Hebei Xuanhua Jiangchengyi Mu 河北宣化辽姜承义墓 [Liao Tomb of Jiang Chengyi at Xuanhua, Hebei]. *Beifang wenwu 北方文物* (04):67-71.
- 1993. Lue Lun Zhangjiakou Diqu Liao Mu Fenqi Wenti 略论张家口地区辽墓分期问题 [Brief Discuss on the Chronological Questions of Liao Tombs in Zhangjiakou Region]. *Beifang wenwu 北方文物* (1).
- Tao Zongyi et al. 陶宗冶等 1990. Hebei Xuanhua Xiabali Liao Jin Bihua Mu 河北宣化下巴里辽金壁画墓 [Liao Tombs with Mural Paintings at Xiabalin, Xuanhua, Hebei]. *Wenwu 文物* (10):1-19.
- The Museum Yamato Bunkakan 大和文華館 1977. *Yamato Bunkakan Shozohin Zuhon Mokuroku 大和文華館所藏品图版目錄 7: 中国陶磁 [Chinese Ceramics from the Museum Yamato Bunkakan Collection: Illustrated Catalogue Series No. 7]*.
- Tian Guanglin 田广林 1995. *Qidan Lisu Kaolun 契丹礼俗考论 [Studies in Qidan Ceremonies and Costumes]*. Harbin: Harbin chubanshe.

- Tian Li & Qi Xiaoguang 田莉 & 齐晓光 1986. Aluke'erqinqi Chaidamu Liao Mu 阿鲁科尔沁旗柴达木辽墓 [Liao Tomb at Chaidamu, Aluke'erqin Banner]. *Neimenggu wenwu kaogu 内蒙古文物考古* (4):77-79.
- Tian Qi & Zhou Yan 1994. *Zhongguo Song Liao Jin Xia Yi Shu Shi 中国宋辽金夏艺术史 [Art History of Chinese Song, Liao, Jin and Xia Dynasties]*, Bai Juan Ben *Zhongguo Quan Shi* : 59. Beijing: Ren min chu ban she.
- Tian Shuhua 田淑华 1986. Chengde Xian Sangou Cun Faxian Liao Jin Jiaocang 承德县三沟村发现辽金窖藏 [Liao Hoard Found at Sangou Village, Chengde County]. *Wenwu 文物* (6):83-86.
- Tianjin lishi bowuguan kaogudui et al. 天津历史博物馆考古队 1989. Tianjin Ji Xian Dulesi Ta 天津蓟县独乐寺塔 [the Pagoda of Dule Monastery in Jixian, Tianjin]. *Kaogu xuebao 考古学报* (1):83-119.
- Tianjin lishi bowuguan kaogudui 天津历史博物馆考古队 2001. Tianjin Ji Xiang Mile Yuan Cun Liao Mu 天津蓟县弥勒院村辽墓 [Liao Tomb at Mileyuan Village, Ji County, Tianjin]. *Wenwu chunqiu 文物春秋* (6):19-23 , 31.
- Tietze, K. 1979. The Liao-Sung Border Conflict of 1074-1076. In *Studia Sino-Mongolica: Festschrift Fuer Herlbert Franke*, edited by B. Wolfgang. Wiesbaden: Franz Steiner.
- Tite, M. S., I. C. Freestone, R. Mason, J. Molera, M. Vendrell-Saz, and N. Wood 1998. Lead Glazes in Antiquity--Methods of Production and Reasons for Use. *Archaeometry* 40 (2):241-260.
- Tokyo Kokuritsu Hakubutsukan 東京國立博物館 1965. *Tokyo Kokuritsu Hakubutsukan Zuhan Mokuroku: Chugoku Kotoji Hen 東京國立博物館圖版目錄：中國古陶磁篇 [Illustrated Catalogue of Tokyo National Museum, Chinese Ceramics]*. Tokyo: Benrido 便利堂.
- Tomita Kojiro & Kai-ming Chiu 1948. Chinese Leather Wine Bottles and Their Ceramic Imitations. *Oriental Art* 1 (3):122-124.
- Tong Baoshan & He Lin 佟宝山 & 贺林 2002. Cong Fuxin Guanshan Liaomu Kan Liaodai Houzu De Lishi Huodong 从阜新关山辽墓看辽代后族的历史活动 [the Historical Movement of the Branch of Liao Empress from Liao Tomb at Guanshan, Fuxin]. *Liaoning gongcheng jishu daxue xuebao (shehui kexue ban) 辽宁工程技术大学学报(社会科学版)* (01).
- Tong Baoshan 佟宝山 2005. Lun Qidan Ren Zai Mengyuan Shidai De Yingxiang 论契丹人在蒙元时代的影响 [on High- Ranking Military Officials in Meng- Yuan Era]. *Qinghai minzu yanjiu 青海民族研究* (3).
- Tong Jiajiang 佟佳江 1988. Qidan De Shehui Xingzhi 契丹的社会性质 [Social Nature of Khitan]. *Neimenggu minzu daxue xuebao(shehui kexue ban) 内蒙古民族大学学报(社会科学版)* (03).

- Tong Zhuchen 佟柱臣 1944. Chifeng Gangwa Yao Liaodai Yaozhi Fajue Tongbao 赤峰缸瓦窑辽代窑址发掘通讯 [News Report on the Excavations of Liao Kiln Sites at Gangwayao, Chifeng]. *Shengjing shibao 盛京时报* (Aug.18-20).
- 1989. Lun Liao Ci De Jige Wenti 论辽瓷的几个问题 [Several Problems About the Porcelain of Liao Dynasty]. In *Zhongguo Dongbei Qiqu He Xinshiqi Shidai Kaogu Lunwen Ji 中国东北地区和新石器时代考古论文集 [Selected Works of the Archaeology of Northeast China and the Neolithic Archaeology of China]*. Beijing: Wenwu chubanshe.
- 1991. Liaomu Bihua Suo Fanying De Qidan Ren Shenghuo 辽墓壁画所反映的契丹人生活 [Life of Reflected by the Mural Paintings of Liao Tombs]. In *Liao Jin Shi Lun Ji 辽金史论文集* Beijing: Wenjin chubanshe.
- Torri Ryuzo 鳥居龍藏 1931. Ryodai No Hekiga Ni Tsuite [Liao-Dynasty Wall Paintings]. *Kokka* (490-493).
- 1936. *Kokogakujo Yori Mitaru Ryo No Bunka: Zufu 考古学上よりたる遼の文化図譜 [Illustrations of Archaeology Supplementary to the Culture of the Liao Dynasty from the Viewpoint of Archaeology]*. Tokyo: Tohobunka gakuin Tokyo kenkyusho 东方文化学院東京研究所.
- 1941. Shimian Diaoke Zhi Bohai Ren Fengsu Yu Sashan Shi Huping 石面雕刻之渤海人风俗与萨珊式胡瓶. *Yanjing xuebao 燕京学报* (30).
- 1942. *Sculptured Stone Tombs of the Liao Dynasty*. Peking: Harvard-Yenching Institute.
- 1949. Liao Shangjing Cheng Nei Yicun Zhi Shiren Kao 辽上京城内遗存之石人考. *Yanjing xuebao 燕京学报* (36).
- 1950. Liao Zhongjing Chengnei Yicun Zhi Er Shi Xiang Kao 辽中京城内遗存之二石像考. *Yanjing xuebao 燕京学报* (50).
- Tregear, Mary 1982. The Classic Northern White Wares of the Northern Song and Jin Dynasties. *Bulletin of the Oriental Ceramic Society of Hong Kong* (6).
- Tsao Hsingyuan 1996. From Appropriation to Possession : A Study of the Cultural Identity of the Liao through Their Pictorial Art. Thesis (Ph D), Stanford University, 1996.
- Tsao Hsingyuan, Douglas F. Cooley Memorial Art Gallery., Boston University Art Gallery., Boise Art Museum., and Middlebury College Museum of Art Gallery. 2000. *Differences Preserved : Reconstructed Tombs from the Liao and Song Dynasties*. Portland, Ore.: Douglas F. Cooley Memorial Art Gallery, Reed College.
- Tuo Tuo et al. 脱脱等 1974. *Liao Shi 辽史 [a History of the Liao Dynasty], Completed in 1344*. 3 vols. Beijing: Zhonghua shuju.
- Vidale, Massimo 1990. Stoneware Industry of the Indus Civilization: An Evolutionary Dead-End in the History of Ceramic Technology. In *The Changing Roles of Ceramics in Society: 26,000*

B.P. To the Present: Ceramics and Civilization, edited by W. D. Kingery. Columbus OH: The American Ceramic Society Inc.

- Wan Xin 万欣 1999. Liaoning Zhangwu De Sanzuo Liaomu 辽宁彰武的三座辽墓 [Three Tombs of Liao Dynasty in Zhangwu County, Liaoning]. *Kaogu yu wenwu 考古与文物* (6):15-23.
- Wan Xiongfei 万雄飞 2005. Fuxin Liao Xiaohe Mu Fajue Jianbao 阜新辽萧和墓发掘简报 [a Brief Report of Excavations of the Liao Tomb of Xiaohe at Fuxin]. *Wenwu 文物* (1):33-44.
- Wang Changchun & Wei Guoqiang 王长春 & 魏国强 2000. Liaodai Sancai Xun 辽代三彩埴 [Three-Color Glazed Ocarina of Liao Dynasty]. *Neimenggu wenwu kaogu 内蒙古文物考古* (2):108.
- Wang Cheng & Chen Fengshan 王成 & 陈凤山 1991. Neimenggu Xin Ba'erhu Zuoqi Ganzhu'erhua Shiguan Mu Qun Diaocha Qingli Jianbao 内蒙古新巴尔虎左旗甘珠尔花石棺墓群调查清理简报 [a Brief Report on Clearing up of the Tombs with Stone Coffins at Ganzhu'erhua, Xin Ba'erhu Bannner, Inner Mongolia]. *Hulunbei'er wenwu 呼伦贝尔文物* (1).
- 1992. Xin Ba'erhu Zuoqi Ganzhu'erhua Shiguan Mu Qun Qingli Jianbao 新巴尔虎左旗甘珠尔花石棺墓群清理简报 [a Brief Report on Clearing up of the Tombs with Stone Coffins at Ganzhu'erhua, Xin Ba'erhu Bannner]. *Neimenggu wenwu kaogu 内蒙古文物考古* (1-2).
- 1997. Chenba'erhu Qi Bayankuren Zhen Liaodai Mu Qun Diaocha Qingli Jianbao 陈巴尔虎旗巴彦库仁镇辽代墓群调查清理简报 [a Brief Report on Clearing up of Liao Tombs at Bayankuren Township of Chenba'erhu Banner]. *Hulunbei'er wenwu 呼伦贝尔文物* (4).
- Wang Chengguo 王成国 2004. Lun Tangdai Qidan 论唐代契丹 [Discuss on Khitan of Tang Dynasty]. *Shehui kexue zhanxian 社会科学战线* (02):163-67.
- Wang Chengli 王承礼 1984. *Bohai Jianshi 渤海简史* [a Concise History of Bohai]. Harbin: Heilongjiang remin chubanshe.
- Wang Chengsheng 王成生 1987. Liaoning Chaoyang Shi Liao Liuchengci Zu Mu 辽宁朝阳市辽刘承嗣族墓 [Liao Tomb of Liu Chengci at Chaoyang, Liaoning]. *Kaogu 考古* (2).
- Wang Dafang & Guo Zhizhong 王大方 & 郭治中 1996. Chifengshi Songshan Qu Gangwayao Yizhi Fajue Huo Zhongda Xin Chengguo 赤峰市松山区缸瓦窑遗址发掘获重大新成果 [Important New Achievement on the Excavations of Gangwayao Kiln Sites at Songshan District, Chifeng City]. *Zhongguo wenwu bao 中国文物报*, Apr.28.
- Wang Dezhong 王德忠 2002. Lun Liaochao Wujing De Chengshi Gongneng 论辽朝五京的城市功能 [Discuss on the City Function of the Five Capitals of Liao Dynasty]. *Beifang wenwu 北方文物* (1):77-81 , 90.

- Wang Gang & Lü Qing 王刚 & 吕清 2001. Linxi Xian Wujian Fang Liaomu Qingli Jianbao 林西县五间房辽墓清理简报 [a Brief Report on the Excavations of Liao Tomb at Wujianfang, Linxi County]. *Neimenggu wenwu kaogu 内蒙古文物考古* (01):124-126.
- Wang Gang 王刚 1997. Neimenggu Linxi Xian Wenguansuo Shoucang De Wenwu 内蒙古林西县文管所收藏的文物 [Cultural Relics Collected in the Cultural Relic Administration Center of Linxi County, Inner Mongolia]. *Neimenggu wenwu kaogu 内蒙古文物考古* (1):101.
- 1998. Linxi Xian Xiaohada Liaomu 林西县小哈达辽墓 [Liao Tomb at Xiaohada, Linxi County]. *Neimenggu wenwu kaogu 内蒙古文物考古* (1):44-49.
- 2004. Neimenggu Linxi Xian Xiaohada Liao Mu 内蒙古林西县小哈达辽墓 [Liao Tomb at Xiaohada, Linxi County, Inner Mongolia]. *Kaogu 考古* (1).
- Wang Guangyao 王光尧 2004. *Zhongguo Gu Dai Guan Yao Zhi Du 中国古代官窑制度 [the Official Kiln System of Ancient China]*. Di 1 ban. ed, *Zi Jin Shu Xi. Di 1 Ji* . Beijing: Zi jin cheng chu ban she.
- Wang Guofan 王国范 1982. Shuangliao Nongchang Liaomu Qingli Jianbao 双辽农场辽墓清理简报 [a Brief Report on Clearing up of Liao Tomb at Shuangliao Farm]. *Jilin wenwu kaogu huibian 吉林文物考古汇编*.
- Wang Hongda 王弘达 1995. Qidan Zu Zai Fuxin Diqu Yiji Zong Xi 契丹族在阜新地区遗迹综析 [Comprehensive Analysis on the Sites of Khitan in Fuxin Region]. *Fuxin Liao jin shi yanjiu 阜新辽金史研究* (2).
- Wang Huimin & Zhang Zhizhong 王会民 & 张志中 1997. Xingyao Diaochao Shijun Zhuyao Shouhuo 邢窑调查试掘主要收获 [Main Achievement on the Investigations and Tentative Excavations at Xing Kiln Site]. *Wenwu chunqiu 文物春秋* (Z1):8-14.
- Wang Huimin et al. 王会民等 1998. Xing Yao Wenti Xin Yi 邢窑问题新议 [New Discuss on Questions of Xing Kiln]. In *Heibeisheng Kaogu Wenji 河北省考古文集*, edited by Heibeisheng wenwu yanjiusuo: Dongfang chubanshe.
- Wang Jian 王健 1983. Jilin Shuangliao Xian Faxian Liang Zuo Liao Mu 吉林双辽县发现两座辽墓 [Two Liao Tombs Have Been Discovered at Shangliao County, Jilin]. *Kaogu 考古* (8):753-754
- Wang Jianguo & Ma Junshan 王建国 & 马俊山 1986. Aluke'er Qin Qi Wulanhada Liaomu 阿鲁科尔沁旗乌兰哈达辽墓 [Liao Tomb at Wulanhada, Aluke'erqin Banner]. *Neimenggu wenwu kaogu 内蒙古文物考古* (4):74-76.
- Wang Jianguo 王建国 1987. Chifeng Gangwa Yao Liaodai Yaozhi Shijue Jianbao 赤峰缸瓦窑辽代窑址试掘简报 [a Brief Report on the Tentative Excavations at Liao Kiln Sites at Gangwayao Village, Chifeng]. *Songzhou xuekan 松州学刊* (4-5).

- Wang Jianqun & Chen Xiangwei 王健群 & 陈相伟 1989. *Kulun Liao Dai Bihua Mu 库伦辽代壁画墓* [Murals in Liao Dynasty Tombs in Kulun Banner]. Di 1 ban. ed. Beijing: Wenwu chubanshe.
- 1997. *Kulun Liaomu Fajue Baogao 库伦辽墓发掘报告* [Excavation Report of Liao Tombs at Kulun]. In *Zhongguo Kaogu Jicheng (Dongbei Juan) 中国考古集成 (东北卷)*. Beijing: Beijing chubanshe.
- Wang Jianqun 王健群 1978. *Kulunqi Erhao Liaomu Fajue Sanji 库伦旗二号辽墓发掘散记* [a Cursory Record of the Excavations of Liao Tomb at Kulunqi]. *Shehui kexue zhanxian* (1):209-213.
- Wang Ju'er 王菊耳 1981. *Shenyang Liutiaohu Liaodai Shiguan Mu 沈阳柳条湖辽代石棺墓* [Liao Tomb with Stone Coffin at Liutiaohu, Shenyang]. *Liaoning wenwu 辽宁文物* (1).
- Wang Laizhu 王来柱 1996. *Zhangwu Chaidama Liaomu Fajue Jianbao 彰武差大马辽墓发掘简报* [a Brief Report on Excavations of Liao Tomb at Chadama, Zhangwu]. *Liaohai wenwu xuekan 辽海文物学刊* (01):66-68.
- Wang Ling 王玲 1990. *Beijing Tongshi : Liao Dai Juan 北京通史·辽代卷* [Peking History: Volume of Liao Dynasty]. Beijing: Beijing yanshan chubanshe 北京燕山出版社.
- Wang Lixia & Zhang Jingming 王丽霞 & 张景明 2003. *Liaodai Qidan Minzu De Renkou Ji Tedian 辽代契丹民族的人口及特点* [Population and Characteristic of Khitan Ethnic Group of Liao Dynasty]. *Sixiang zhanxian 思想战线* (04):114-18.
- Wang Pinglu 王平鲁 1985. *Liaoning Fushun Shi Guangming Jie Liaomu Fajue Jianbao 辽宁抚顺市光明街辽墓发掘简报* [a Brief Report on Excavations of Liao Tomb at Guangming Street of Fuxin City, Liaoning]. *Liaojin qidan nuzhen shi yanjiu 辽金契丹女真史研究* (1).
- Wang Qing 王晴 1979. *Liao Shangjing Yizhi Jiqi Chutu Wenwu Jishu 辽上京遗址及其出土文物记述* [a Report with Regard to the Site of the Liao Main Capital and the Cultural Relics Unearthed]. *Wenwu tongxun 文物通讯* (8):3-14.
- Wang Qinglin et al. 王清林等 2002. *Fengtai Lukou Nan Chutu Liao Mu Qingli Jianbao 丰台路口南出土辽墓清理简报* [a Brief Report on Clearing up of Liao Tomb at the South of Intersection of Fengtai Street]. *Beijing wenbo 北京文博* (2):38-43.
- Wang Qingzheng et al. 汪庆正等 2002. *Zhongguo Taoci Cidian 中国陶瓷辞典* [a Dictionary of Chinese Ceramics]. Singapore: Sun Tree Publishing Limited.
- Wang Qiuhua 王秋华 1982. *Liaodai Muzang De Fenqu Yu Fenqi De Chutan 辽代墓葬的分区与分期的初探* [a Preliminary Examination of the Geographical Distribution and Chronological Classification of Liao Tombs]. *Liaoning daxue xuebao 辽宁大学学报* (3):43-46.

- 1994. Liaodai Qidan Zu Muzang Bihua Zhuangshi Fenqi 辽代契丹族墓葬壁画分期 [Chronological Classification on the Mural Paintings of Khitan Tombs of Liao Dynasty]. *Beifang wenwu* 北方文物 (01).
- Wang Renbo 王仁波 1982. Shaanxi Tangmu Chutu Sancai qi Zongshu 陕西省唐墓出土三彩器综述 [a Comprehensive Account of the Three-Colored Wares Unearthed from Tang Tombs in Shaanxi Province]. *Wenwu ziliao congkan* 文物资料丛刊 (6):139-150.
- Wang Weixiang 王未想 1999. Neimenggu Balin Zuoqi Dishuihu Liaodai Bihua Mu 内蒙古巴林左旗滴水壶辽代壁画墓 [Liao Tomb with Mural Paintings at Dishuihu, Balin Left Banner, Inner Mongolia]. *Kaogu* 考古 (8).
- Wang Wuyu & Qi Qingguo 王武钰 & 祁庆国 1991. Shunyi Xian Liaodai Zhuanshi Mu 顺义县辽代砖室墓 [Liao Tomb with Brick Chamber at Shunyi County]. In *Zhongguo Kaogu Xue Nianjian (1990 Nian)* 中国考古学年鉴 (1990年). Beijing: Wenwu chubanshe.
- Wang Yingying 王英鹰 1989. Liao Baici Qianxi 辽白瓷浅析 [Brief Discuss on Liao White Glazed Porcelains]. In *Shenyang Gugong Bowuguan Shoujie Xueshu Taolunhui Wenji* 沈阳故宫博物馆首届学术讨论会文集. Shenyang Liaoning renmin chubanshe.
- Wang Yinqing 王胤卿 2004. Qidan Minzu Jiguanhu De Wenhua Quanshi 契丹民族鸡冠壶的文化诠释 [Cultural Interpretation on the Bag-Shaped Pilgrim Flasks of Khitan Ethnic Group]. *Neimenggu shehui hexue (hanwen ban)* 内蒙古社会科学(汉文版) (01):15-17.
- 2005. Shilun Liao Ci Jiguanhu Shifou Shiyong De Wenti 试论辽瓷鸡冠壶是否实用的问题 [a Tentative Discuss on the Practicability of Bag-Shaped Pilgrim Flasks of Liao Dynasty]. *Beifang wenwu* 北方文物 (02).
- Wang Yintian 王银田 1994. Datong Liaodai Bihua Mu Cuyi 大同辽代壁画墓刍议 [Discuss on Liao Tombs with Mural Paintings at Datong]. *Beifang wen wu* 北方文物 (02).
- Wang Youquan 王友泉 1991. Fengtai Qu Yongding Lu Faxian Liao Mu 丰台区永定路发现辽墓 [Liao Tombs Found at Yongding Street of Fengtai District]. *Beijing kaogu xinxi* 北京考古信息 (1).
- Wang Youquan 王有泉 1994. Beijing Miyun Yexianta Taji Qingli Jianbao 北京密云冶仙塔塔基清理简报 [a Brief Report on Clearing up of Foundation of the Yexian Pagoda at Miyun, Beijing]. *Wenwu* 文物 (2):58-64.
- Wang Yufang 王玉芳 1994. Xiuyan Xindian Xiang Faxian Liaodai Bihua Mu 岫岩新甸乡发现辽代壁画墓 [Liao Tomb with Mural Painting at Xindian Township, Xiuyan]. *Liaohai wenwu xuekan* 辽海文物学刊 (1).
- 1997. Xiuyan Xidian Beimenkou Liaodai Bihua Mu Qingli Jianbao 岫岩新甸北门口辽代壁画墓清理简报 [a Brief Report on the Clearing up of a Liao Tomb with Mural Painting at Xindian, Xiuyan]. In *Zhongguo Kaogu Jicheng (Dongbei Juan)* 中国考古集成 (东北卷). Beijing: Beijing chubanshe.

- Wang Yunzhi 王运至 1980. Liaoning Qingyuanxian Erdaogou Chutu Dingyaoxitong Ciqi 辽宁清原县二道沟出土定窑系统瓷器 [Ding-Type Wares Have Unearthed at Erdaogou, Qingyuan County, Liaoning]. *Wenwu 文物* (10):95-96.
- Wang Yuping 汪宇平 1955a. Neimenggu Wenwu Gongzuozu Diaocha Qidanzu Yizhi 内蒙古文物工作组调查契丹族遗址 [the Inner Mongolia Archaeological Team Made Investigations on Qidan Sites]. *Wenwu 文物* (8):151-152.
- 1955b. Zhaowuda Meng Balin Zuoqi He Youqi Faxian Shuchu Liao Mu 昭乌达盟巴林左旗和右旗发现数处辽墓 [Several Liao Tombs Found at Balin Right and Balin Left Banner, Zhaowuda Union]. *Wenwu cankao ziliao 文物参考资料* (3).
- 1955c. Zhaowuda Meng Lindong Qingli Le Shizuo Liaodai Muzang 昭乌达盟林东清理了十座辽代墓葬 [Ten Liao Tombs Cleared up at Lindong, Zhaowuda Union]. *Wenwu cankao ziliao 文物参考资料* (2).
- 1956. Neimenggu Zhaomeng Balinzuoqi Lindongjie Bei Shanpo Liaodai Yizhi Chutu De Taoqi 内蒙古昭盟巴林左旗林东街北山坡辽代遗址出土的陶器 [Pottery Unearthed from Liao Sites in the Slope North of Lindong Street, Balinzuoqi, Zhaowudameng, Inner Mongolia]. *Wenwu 文物* (2):14-18.
- Wang Zengxin 王增新 1960. Liaoning Liaoyang Jinchang Liao Huaxiangshimu 辽宁辽阳金厂辽画像石墓 [the Liao Tomb with Stone Carvings at Jinchang, Liaoyang, Liaoning]. *Kaogu 考古* (2):25-28.
- Wang Zeqing 王泽庆 1973. Kulunqiyihao Liaomu Bihua Chutan 库伦旗一号辽墓壁画初探 [a Preliminary Investigation of the Mural Paintings of Liao Tomb I at Kulunqi]. *Wenwu 文物* (8):30-35.
- Wang Zhenren et al. 王珍仁等 1995. Lüshun Bowuguan Cang Liao Sancai Tao Yan 旅顺博物馆藏辽三彩陶砚 [Liao Three-Color Glazed Inkstone Collected in Museum of Lüshun]. *Bowuguan yanjiu 博物馆研究* (1).
- Wang Zhilai 王治来 1983. Gaonyu Hou Xi Liao 关于“后西辽” [on the Post-Western Liao]. *Xinjiang shehui kexue 新疆社会科学* (1).
- Wang Zhiwen 王志文 1990. Zhalute Qi Fengshantun Qidan Mu Qingli Jianbao 扎鲁特旗封山屯契丹墓清理简报 [a Brief Report on Clearing up of Khitan Tombs at Fengshantun, Zhalute Banner]. *Beifang wenwu 北方文物* (03).
- Watson, W. 2000. *The Arts of China 900-1620*: Yale University Press.
- Watson, William 1984. *Tang and Liao Ceramics*. London: Thames and Hudson.
- Wei Chunguang 魏春光 1989. Faku Faxian Liaodai Zaoqi Muzang 法库发现辽代早期墓葬 [Early Liao Tombs Found at Faku]. In *Zhongguo Kaoguxue Nianjian (1988 Nian) 中国考古学年鉴 (1988年)*. Beijing: Wenwu chubanshe.

- Wei Jian 魏坚 1997. Neimenggu Qingshuihe Xian Shantiaomao Mudi 内蒙古清水河县山跳峁墓地 [Graveyard at Shantiaomou, Qingshuihe County, Inner Mongolia]. *Wenwu* (1):20-35.
- Wei Jianyou 魏建猷 1934. Ri Ren Niaoju Longcang Shi Diaocha Rehe Sheng Nei Qidan Wenhua De Jingguo 日人鸟居龙藏氏调查热河省内契丹文化的经过. *Yanjing xuebao* 燕京学报 (15).
- Wei Liangtao 魏良弢 1983. Kalahan Wangchao Yu Song Liao Ji Gaochang Huihu De Guanxi 喀喇汗王朝与宋、辽及高昌回鹘的关系 [Relationships between Kala Khan Dynasty and Song, Liao, and Gaochang Uighur Dynasties]. In *Zhongya Xuekan* 中亚学刊. Beijing: Zhonghua shuju.
- 1987a. *Xi Liao Shi Yanjiu* 西辽史研究 [Study of Western Liao History]. Yinchuan: Ningxia renmin chubanshe.
- 1987b. *Xi Liao Wangchao Jiangyu Kaoshi* 西辽王朝疆域考释 [Research on the Territory of Western Liao Dynasty]. In *Lishi Dili* 历史地理. Shanghai: Shanghai renmin chubanshe.
- 1991. *Xi Liao Shi Gang* 西辽史纲 [History of Western Liao]. Beijing: Renmin chubanshe.
- Wei Zhankui 魏占奎 2002. *Liao Yan* 辽砚 [Liao Inkstone]. Di 1 ban. ed, *Liao Dai Wen Wu Cong Shu*. Shenyang: Liaoning huabao chubanshe.
- Wei Zhijiang 魏志江 1996. Lun Liao Yu Gao Li Guanxi De Fenqi Jiqi Fazhan 论辽与高丽关系的分期及其发展 [Discuss on Chronological Classification of the Relationship between Liao and Gaoryeo and Its Development]. *Yanzhou shiyuan xuebao* 扬州师院学报 (1).
- 1997. Lun 1020-1125 Nian De Liao Li Guanxi 论 1020—1125 年的辽丽关系 [Discuss on the Relationship between Liao and Goryeo from 1020-1125]. *Nanjing daxue xuebao* 南京大学学报 (1).
- 2000. Liao Jin Yu Gaoli De Jingji Wenhua Jiaoliu 辽金与高丽的经济文化交流 [Economic and Cultural Exchanges between Goryeo and Liao and Jin Dynasty] *Shehui kexue zhanxian* 社会科学战线 (5).
- 2001. *Liao Jin Yu Gaoli Guanxi Kao* 辽金与高丽关系考 [Discuss on the Relationship between Goryeo and Liao and Jin Dynasty]. Hong Kong: Tianma tushu Ltd.
- Wen Lihe 温丽和 1989. Liaoning Faku Xian Yemaotai Liao Xiaoyi Mu 辽宁法库县叶茂台辽萧义墓 [the Liao Tomb of Xiao Yi near Yemaotai Village in Faku County, Liaoning Province]. *Kaogu* 考古 (4):324-30.
- 1997a. Faku Yemaotai Gu Mu Qun 法库叶茂台古墓群 [Ancient Tombs Group at Yemaotai, Faku]. In *Zhongguo Kaogu Jicheng (Dongbei Juan)* 中国考古集成 (东北卷). Beijing: Beijing chubanshe.

- 1997b. Yemaotai Mu Yu Liao Chao Hou Zu Xiao Shi 叶茂台辽墓与辽朝后族萧氏 [Liao Tombs at Yemaotai and the Xiao Family of Liao Empresses' Series]. In *Zhongguo Kaogu Jicheng (Dongbei Juan) 中国考古集成 (东北卷)*. Beijing: Beijing chubanshe.
- Wenwu bianji weiyuanhui 文物编辑委员会 1979. *Wenwu Kaogu Gongzuo Sanshinian 文物考古工作三十年 [Thirty Years of Reseach Work on Archaeology]*. Beijingg: Wenwu chubanshe.
- 1984. *Zhongguo Gudai Yaozhi Diaocha Fajue Baogaoji 中国古代窑址调查发掘报告集 [Collected Report with Regard to the Excavations and Investigations of Ancient Chinese Kiln Sites]*. Edited by 文. Wenwu bianji weiyuanhui. Beijing: Wenwu chubanshe.
- Wirgin, Jan 1960. Some Notes on Liao Ceramics. *Bulletin of the Museum of Far Eastern Antiquities* (no.32):25-46.
- 1970. *Sung Ceramic Designs*. London: Han-shan Tang Ltd.
- Wittfogel, Karl A. 1947. Public Office in the Liao Dynasty and the Chinese Examination System. *Harvard Journal of Asiatic Studies* 10 (1):13-40.
- 1957. Chinese Society: An Historical Survey. *The Journal of Asian Studies* 16 (3):343-364.
- Wittfogel, Karl August, and Chia-shêng Fêng 1949. *History of Chinese Society : Liao (907-1125), Transactions of the American Philosophical Society ; N. S. 36*. Philadelphia: American Philosophical Society, distributed by the Macmillan Co., New York.
- Wood, Nigel 1999a. *Chinese Glazes: Their Origins, Chemistry, and Recreation*. Philadelphia: University of Pennsylvania Press.
- Wood, Nigel 1999b. A Glow in the Dark: Borate Glazes Proven a Thousand Years Old *PIONEER MAGAZINE*, <http://www.borax.com/pioneer37.html>.
- Wright, David Curtis 1998. *The Ambassadors Records : Eleventh-Century Reports of Sung Embassies to the Liao*. Bloomington, Ind.: Indiana University, Research Institute for Inner Asian Studies.
- 2005. *From War to Diplomatic Parity in Eleventh-Century China : Sung's Foreign Relations with Kitan Liao, History of Warfare, V. 33*. Leiden ; Boston: Brill.
- Wu Fengli 乌凤丽 2004. Liao Jin Yuan Shiqi De Lizhou 辽、金、元时期的利州 [Lizhou City in Liao, Jin and Yuan Dynasty]. *Heilongjiang minzu congkan 黑龙江民族丛刊* (02).
- Wu Jiachang 武家昌 1986. Kazuo Beiling Liao Mu 喀左北岭辽墓 [Liao Tomb at Beiling, Kazuo, Liaoning]. *Liaohai wenwu xuekan 辽海文物学刊* (1):32-51.
- 1988. Kangpin Haizhou Liao Mu Qingli Jianbao 康平海州辽墓清理简报 [a Brief Report on the Clearing up of Liao Tomb at Haizhou, Kangping]. *Liaohai wenwu xuekan 辽海文物学刊* (1).

- Wu Jinliang 吴金亮 2001. Liao Jin Longquanwu Yao 辽金龙泉务窑 [Longquanwu Kiln Site of Liao and Jin Dynasty]. *Shoucang 收藏* (8).
- Wu songdi 吴松弟 1997. *Zhongguo Yiminshi: Liao Song Jin Yuan Shiqi 中国移民史·辽宋金元时期* [History of Chinese Immigrants: Liao, Song, Jin and Yuan Period]. Vol. 4. Fuzhou: Fujian renmin chubanshe.
- Wu Yaqin & Li Tiejun 武亚琴 & 李铁军 2001. Zhalute Qi Chutu Liaodai Qiwu 扎鲁特旗出土辽代器物 [Liao Objects Unearthed from Zhalute Banner]. *Neimenggu wenwu kaogu 内蒙古文物考古* (02):96-97.
- Wu Yaqin & Wang Ruiqing 武亚琴 & 王瑞青 2000. Neimenggu Kezuo Zhongqi Xiaonurimu Liao Mu 内蒙古科左中旗小努日木辽墓 [Liao Tomb at Xiaonuri, Kezuo Middle Banner, Inner Mongolia]. *Beifang wenwu 北方文物* (3):32-35.
- Wu Yuhuan 武玉环 1991. Lue Lun Liaodai Qidan Ren De Yi Shi Zhu Xing 略论辽代契丹人的衣食住行 [Brief Discuss on the Basic Necessities of Life of Khitan People in Liao Dynasty]. *Beifang wenwu 北方文物* (3):66-71.
- 2001. Lun Liao Yu Gaoli De Guanxi Ji Liao De Dongbu Bianjiang Zhengce 论辽与高丽的关系及辽的东部边疆政策 [Discuss on the Relationship between Liao and Goryeo and Liao's Eastern Policy]. *Jilin daxue shehui kexue xuebao 吉林大学社会科学学报* (04):76-80.
- Wulanchabumeng bowuguan 乌兰察布盟博物馆 1994. Helinge'er Qianwayao Gou Liaojin Shidai Yizhi 和林格尔县前瓦窑沟辽金时代遗址 [Sites of Liao and Jin Dynasty at Qianwagou, Helinge'er County]. In *Neimenggu Wenwu Kaogu Weuji 内蒙古文物考古文集*, edited by Neimenggu wenwu kaoguyanjiusuo. Beijing: Zhongguo dabaike quanshu chubanshe.
- Wumeng wenwu gongzuozhan & Neimenggu wenwu gongzuodui 乌盟文物工作站&内蒙古文物工作队 1985. Haoqianying Liaomu Dierci Qingli Baogao 豪欠营辽墓第二次清理报告 [a Report of the Second Clearing up of Liao Tombs at Haoqianying]. In *Qidan Nüshi: Haoqianying Liaomu De Qingli Yu Yanjiu 契丹女尸——豪欠营辽墓的清理与研究*, edited by W. w. g. z. N. w. gongzuodui , . Huhehaote: Neimenggu renmin chubanshe.
- Wumeng wenwu gongzuozhan 乌盟文物工作站 1985. Haoqianying Liaomu Diyici Qingli Baogao 豪欠营辽墓第一次清理报告 [a Report of the First Clearing up of Liao Tombs at Haoqianying]. In *Qidan Nüshi: Haoqianying Liaomu De Qingli Yu Yanjiu 契丹女尸--豪欠营辽墓的清理与研究* [the Remains of Khitan Females], edited by Wumeng wenwu gongzuo zhan & Neimenggu wenwu gongzuodui. Huhehaote: Neimenggu renmin chubanshe.
- Wusheng chutu zhongguo wenwu zhanlan choubei weiyuanhui 五省出土中国文物展览筹备委员会 1958. *Wusheng Chutu Zhongyao Wenwu Zhanlan Tulu 五省出土中国文物展览图录* [Catalogue of an Exhibition of Important Objects Excavated in Five Provinces]. Beijing: Wenwu chubanshe.

- Xi Mude 希木德 1988. Neimeng Tongliao Xian Yuliangbao Liao Mu 内蒙通辽县余粮堡辽墓 [Liao Tomb at Yuliangbao, Tongliao County, Inner Mongolia]. *Beifang wenwu 北方文物* (1):41-42.
- Xia Nai 夏鼐 1978. Jinnian Zhongguo Chutu De Sashan Chao Wenwu 近年中國出土的薩珊朝文物 [Relics of Sasan Kingdom from Recent Discoveries]. *Kaogu* (2):111-116.
- Xian Junyan 佺峻岩 1996. Liaodai Huanse You Ci Chutan 辽代黄色釉瓷初探 [Preliminary Discuss on Yellow Glazed Wares of Liao Dynasty]. *Liaoning daxue xuebao (zhexue shehui kexue ban) 辽宁大学学报(哲学社会科学版)* (04).
- 1997a. Kangping Zhangjiayao Linchang Liaomu Qingli Jianbao 康平张家窑林场辽墓清理简报 [a Brief Report on Clearing up of Liao Tombs at Zhangjiayao Farm of Kangping]. *Bowuguan yanjiu 博物馆研究* (1).
- 1997b. Shenyang Tawan Wugou Jinguanta Tagong Chutu Ciqi Kaobian 沈阳塔湾无垢净光舍利塔塔宫出土瓷器考辨 [Research on the Ceramics Unearthed from the Foundation of Wugoujinguang Pagoda at Tawan, Shenyang]. *Liaohai wenwu xuekan 辽海文物学刊* (1):62-64.
- Xiang Chunsong & Wu Dianzhen 项春松 & 吴殿珍 1982. Neimenggu Ningcheng Liao Dengzhongju Mu 内蒙古宁城辽邓中举墓 [the Liao Tomb of Deng Zhongju at Ningcheng, Inner Mongolia]. *Kaogu 考古* (3):281-283.
- Xiang Chunsong 项春松 1979a. Liaoning Zhaowuda Diqu Faxian De Liaomu Huihua Ziliao 辽宁昭乌达地区发掘的辽墓绘画资料 [Materials on the Mural Paintings Found in a Liao Dynasty Tomb at Zhaowuda, Liaoning Province]. *Wenwu tongxun 文物通讯* (6):22-32.
- 1979b. Neimenggu Jiefangyingzi Liaomu Fajue Jianbao 内蒙古解放营子辽墓发掘简报 [a Brief Report of the Excavations of a Liao Tomb at Jiefangyingzi, Inner Mongolia]. *Kaogu 考古* (4):330-334.
- 1981a. Neimenggu Shanzuizi Gu Yelushi Mu Fajue Baogao 内蒙古山咀子故耶律氏墓发掘报告 [a Brief Report of the Excavations of the Tomb of Gu Yelushi at Shanzuizi, Inner Mongolia]. *Wenwu ziliao congkan 文物资料丛刊* (1):167-171.
- 1981b. Shangshaoguo Liao Mu Qun 上烧锅辽墓群 [a Group of Liao Tombs at Shangshaoguo]. *Neimenggu wenwu kaogu 内蒙古文物考古* (1):56-63.
- 1981c. Zhaomeng Diqu De Liaodai Muzang: Jiantan Liamu Fenqi Jiqi Suizangqiwu De Duandai Wenti 昭盟地区的辽代墓葬——兼谈辽墓分期及其随葬器物的断代问题 [Liao Tombs in the Zhaowudameng Area]. *Neimenggu wenwu kaogu 内蒙古文物考古* 1:73-79.
- 1984a. Keshiketeng Qi Erba Di Yi Er Hao Liao Mu 克什克腾旗二八地一、二号辽墓 [Liao Tomb and at Erbadi, Keshiketeng Banner]. *Neimenggu wenwu kaogu 内蒙古文物考古* (3):80-90.

- 1984b. *Liaodai Bihua Xuan 辽代壁画选 [a Selection of Liao-Dynasty Mural Paintings]*. Shanghai: Shanghai renmin meishu chubanshe.
- 1985. Chifeng Faxian De Qidan Liujin Yinqi 赤峰发现的契丹鍍金银器 [the Qidan Gilt Silver Wares Discovered at Chifeng]. *Wenwu 文物* (2):94-96.
- 1986. Liaodai Muzang De Minzu Fengge 辽代墓葬的民族风格 [Ethnic Style of Liao Tombs]. *Songzhou xuekan 松州学刊* (6).
- 1987a. Jiefangyingzi Liao Bihua Mu Fajue Baogao 解放营子辽壁画墓发掘报告 [Excavation Report of Liao Tomb with Mural Painting at Jiefangyingzi]. *Songzhou xuekan 松州学刊* (4-5).
- 1987b. Liaodai De Bihua Yishu 辽代的壁画艺术 [Art of Mural Painting of Liao Dynasty]. *Songzhou xuekan 松州学刊* (4-5).
- 1987c. Liaomu Xingzhi De Yanbian Jiqi Qiwu De Fenqi Bianren 辽墓形制的演变及其器物的分期辨认 [Evolution of the Shapes of Liao Tombs and the Chronological Identification of the Burial Objects]. *Songzhou xuekan 松州学刊* (4-5).
- 1989. Neimenggu Wengniute Qi Liaodai Guangde Gong Mu 内蒙古翁牛特旗辽代广德公墓 [the Liao Tomb at Guangdegong, Wengniute Banner, Inner Mongolia]. *Beifang wenwu 北方文物* (04):41-44.
- 1990. Neimenggu Chifeng Jiaoqu Xindi Liaomu 内蒙古赤峰郊区新地辽墓 [Liao Tombs at Xindi of the Outskirt of Chifeng City, Inner Mongolia]. *Beifang wenwu 北方文物* (4):38-41.
- 1991. Chifengshi Jiaoqu Faxian De Liaomu 赤峰市郊区发现的辽墓 [Newly Discovered Liao Tombs at the Outskirt of Chifeng]. *Beifang wenwu 北方文物* (03):33-39.
- 1996. *Liaodai Lishi Yu Kaogu 辽代历史与考古 [History and Archaeology of the Liao Dynasty]*. Hohhot: Neimenggu renmin chubanshe.
- 1999. *Chifeng Gudai Yishu 赤峰古代艺术 [Art of Ancient Chifeng]*. Huhehaote: Neimenggu daxue chubanshe 内蒙古大学出版社.
- Xiao Zhihua 肖志华 2001. Liaodai Zaoxing Yu Zhuangshi Yishu 辽瓷造型与装饰艺术 [Formative and Decorative Art of Liao Ceramics]. *Wenwu shijie 文物世界* (06).
- 2006. Qidan Zu De Wenhua Tese Yu Zhongyuan Hanzu De Guanxi 契丹族的文化特色与中原汉族的关系 [Cultural Features of Khitan Ethnic Group and Its Relationship with Han People of Central Plain]. *Wenwu shijie 文物世界* (02):3-8.
- Xie Mingliang 谢明良 1979. Liao De Pinangshi Jiguanhu 辽的皮囊式鸡冠壶 [Bag-Shaped Pilgrim Flasks of the Liao Dynasty]. *Xiongshi meishu 雄狮美术* (103):138-146.

- 1987. Youguan 'Guan' He 'Xin Guan' Kuan Baici Guan Zi Hanyi De Jige Wenti 有关“官”和“新官”款白瓷“官”字含义的几个问题 [on Interpreting the Meaning of the Guan Character in the Guan and Xin Guan Inscriptions Seen on Some White Wares]. *Gugong wenwuyueka* (5.2):1-38.
- 1992. Tuohu Zaji 唾壶杂记 [Notes on the Spittoon]. *Gugong wenwuyueka* (10.2):34-47.
- 1998. Yaozhouyao Yizhi Wudai Qingci De Niandai Wenti: Cong Suowei De Caiyao Tanqi 耀州窑遗址五代青瓷的年代问题——从所谓的柴窑谈起. *Gugong wenwu yuekan 故宫文物月刊* 16 (2).
- 2000. Ji Pinang Shi Hu 记皮囊式壶 [Research Notes on Bag-Shaped Flasks]. *Gugong wenwuyueka* (18.1):46-63.
- 2006. Some Thoughts on the Origins of Liao Ceramics. 37 (6):65-68.
- Xin Jian & Cui Fulai 辛建 & 崔福来 1991. Qiqiha'er Shi Meilisi Sanhe Zhuanchang Liaodai Zhuanshi Mu Qingli Jianbao 齐齐哈尔市梅里斯三合砖厂辽代砖室墓清理简报 [a Brief Report on Clearing up of Liao Tomb with Brick Chamber at Sanhezhuanchang, Meilisi, Qiqiha'er]. *Beifang wenwu 北方文物* (02):30-31.
- Xin Yan & Hua Yubing 辛岩 & 华玉冰 1991. Liaoning Jianping Xian Liangchu Liaomu Qingli Jianbao 辽宁建平县两处辽墓清理简报 [a Brief Report on Two Liao Tombs at Jianping County, Liaoning]. *Beifang wenwu 北方文物* (03):40-47.
- Xiong Liao 2003. *Zhongguo Li Dai Ci Qi Zhuang Shi Tu Dian 中国历代瓷器装饰图典 [Illustrated Dictionary of the Designs of Ceramics of Ancient China]*. Edited by H. Xiong. 880-04 Di 1 ban. ed. Shanghai: Shanghai wen hua chu ban she.
- Xu Bingkun 徐秉琨 1983. *Liao Mu Liao Ta Chutu Wenwu 辽墓辽塔出土文物 [Relics Found in Liao Tombs and Pagodas]*. Beijing: Wenwu chubanshe.
- Xu Bingkun & Sun Shoudao ed. 徐秉琨&孙守道 1998. *Dongbei Wenhua:Baishan Heishuizhong De Nongmu Wenming 东北文化：白山黑水中的农牧文明 [Farming and Herding Culture of the Northeast]*. Edited by S. Xu Bingkun & Sun. Hong Kong: Commercial Press(Hong Kong)Ltd . .
- Xu Jianzhong 徐建中 2002. Huai'an Xian Faxian Liaodai Muzang 怀安县发现辽代墓葬 [Liao Tombs Found at Hua'an County]. *Wenwu chunqiu 文物春秋* (01).
- Xu Jisheng 许继生 1999. Heilongjiang Sheng Qiqiha'er Fula'erji Liaomu Qingli Jianbao 黑龙江省齐齐哈尔富拉尔基辽墓清理简报 [a Biref Report on Clearing up of Liao Tombs at Fula'erji, Qiqiha'er, Heilongjiang]. *Beifang wenwu 北方文物* (03).
- Xu Lin 徐琳 2006. Liaodai Yu Kui Kao 辽代玉魁考 [Research on Jade Kui of Liao Dynasty]. *Kaogu yu wenwu 考古与文物* (04).

- Xu Pingfang 徐苹芳 1984. Liao Jin Yuan Ming 辽金元明 [Liao, Jin, Yuan and Ming]. In *Xin Zhongguo De Kaogu Shouhuo 新中国的考古收获 [Archaeological Achievement of New Chia]*, edited by Zhongguo shehui kexueyuan kaogu yanjiusuo. Beijing Wenwu chubanshe.
- 1986. Songyuanming Kaogu & Liaodai Muzang 宋元明考古&辽代墓葬 [Song Yuan Archaeology & Liao Burials]. In *Zhongguo Dabaike Quanshu Kaogu Juan 《中国大百科全书》考古学卷*. Beijing Zhongguo da baike quanshu chubanshe.
- Xu Xiaodong 许晓东 2001. Fojiao Dui Liao Dai Gongyi De Yingxiang 佛教对辽代工艺的影响 [Buddhist Influence on Liao Technique]. *Gugong bowuyuan yuankan 故宫博物院院刊* (02).
- 2003a. *Liao Dai Yu Qi Yanjiu 辽代玉器研究 [Research on Liao Jades]*. Beijing: Zijincheng chubanshe.
- 2003b. Liaodai De Hupi Gongyi 辽代的琥珀工艺 [Technique on Liao Amber Wares]. *Beifang wenwu 北方文物* (04).
- 2004. Liao Dai De Dong Xi Fang Jiaotong He Hupo De Laiyuan 辽代的东西方交通和琥珀的来源 [East-West Connections and Amber under the Qidans]. In *Song Mo Feng Hua: Qidan Yishu Yu Wenhua 松漠风华：契丹艺术与文化 [Noble Riders from Pine and Deserts: The Artistic Legacy of the Qidan]*, edited by F. S. Jenny. Hong Kong: Xianggang zhongwen daxue wenwu guan.
- Xu Yulin 许玉林, and Liaoningsheng bowuguan 辽宁省博物馆 1977. Liaoning Beipiao Shuiquan Yihao Liaomu Fajue Jianbao 辽宁北票水泉一号辽墓发掘简报 [a Brief Report of the Excavations of Liao Tomb at Shuiquan, Beipiao, Liaoning]. *Wenwu 文物* (12):44-51.
- Xu Zhiguo & Wei Chunguang 许志国 & 魏春光 2000. Faku Yemaotai Di 22 Hao Liaomu Qingli Jianbao 法库叶茂台第 22 号辽墓清理简报 [Brief Report on the Clearing of Tomb Number 22 at Yemaotai. Faku County]. *Beifang wenwu 北方文物* (01):48-51.
- Xue Jingping & Baoxin 薛景平 & 宝兴 1984. Yixian Sidaochazi Liao Liangyuan Mu 义县四道岔子辽梁援墓 [Liao Tomb of Liang Yuan at Sidaochazi, Yi County]. *Liaojin qidan nüzhenshi yanjiu dongtai 辽金契丹女真史研究动态* (2).
- Yabe Yoshiaki 矢部良明 1974. Ryo No Ryoiki Kara Shutsushita Toji No Tenkai 辽の領域から出土した陶磁の展開 [Development of the Ceramics Excavated from the Liao Territory]. *Toyo toji 東洋陶磁 [Oriental ceramic]* (2):21-44
- Yagi Sozaburo 八木装三郎 1944. *Manshu Kokogaku 満州考古学 [Manchurian Archaeology]: Ogiwara-Seibunkan 荻原星文館*.
- Yamashita Taizo 山下泰造 1936. A Khitan Variety of Sung Pottery Discovered in Jehol. *Monumenta Serica 華裔學志* (vol.2):421.

- Yan Chongdong 2004. *Liao Xia Jin Yuan Ling*. Beijing di 1 ban. ed, *Li Dai Di Hou Ling Qin Yan Jiu Shu Xi*. Beijing: Zhongguo qing nian chu ban she.
- Yan Wanzhang 阎万章 1957. Jinxi Xigushan Chutu Qidanwen Muzhiming Yanjiu 锦西孤山出土契丹纹墓志铭研究 [a Study of a Qidan Epitaph Unearthed at Xigushan, Jinxi]. *Kaogu xuebao 考古学报* (2):69-82.
- Yan Yu 雁羽 1960. Jinxi Xigushan Liao Xiao Xiaozhong Mu Qingli Jianbao 锦西孤山辽萧孝忠墓清理简报 [a Brief Report of the Cleaning up of the Liao Tomb of Xiao Xiaozhong at Xigushan, Jinxi]. *Kaogu 考古* (2):34-35.
- Yanbian Chaoxian zizhizhou bowuguan & Helongxian wenhuaju 延边朝鲜族自治州博物馆 & 和龙县文化局 1982. Helong Beida Bohai Muzang Qingli Jianbao 和龙北大渤海墓葬清理简报 [a Brief Report of the Clearing up of Bohai Tombs at Beida , Helong]. *Dongbei kaogu yu lishi 东北考古与历史* (1):200-208.
- Yang Baolong 杨保隆 1990. Liaodai Bohai Ren De Taowang Yu Qianxi 辽代渤海人的逃亡与迁徙 [Exile and Migration of Bohai People of Liao Dynasty]. *Minzu yanjiu 民族研究* (04).
- Yang Boda 杨伯达 1991. Song Liao Jin Yu Qi 宋辽金玉器 [Jade Wares of Song, Liao and Jin Dynasty]. *Yishu jia 艺术家* 33 (5).
- Yang Dongxin 杨东昕 2001. Liaoning Jianping Xian Gushanzi Liao Mu 辽宁建平县古山子辽墓 [Liao Tombs at Gushanzi, Jianping, Liaoning]. *Kaogu 考古* (5):87-88.
- Yang Jing 杨晶 1985. Liaomu Chutan 辽墓初探 [Preliminary Discuss on Liao Tombs]. *Beifang wenwu 北方文物* (4).
- 1987. Liaodai Huozang Mu 辽代火葬墓 [Cremated Tombs of Liao Dynasty]. In *Liao Jin Shi Lun Ji 辽金史论集*, edited by Chen Shu. Beijing Shumu wenxian chubanshe
- 1995a. Liaodai Han Ren Muzang Gaishu 辽代汉人墓葬概述 [General Discuss on Liao Tombs of Han People]. *Wenwu chunqiu 文物春秋* (2):52-58.
- 1995b. Lue Lun Jiguanhu 略论鸡冠壶 [Brief Discuss on Bag-Shaped Pilgrim Flask]. *Kaogu 考古* (7):632-639.
- Yang Shusen 杨树森 1984. *Liao Shi Jian Bian 辽史简编 [Concise History of Liao Dynsaty]*. Shenyang: Liaoning renmin chubanshe.
- Yang Wenshan 杨文山 1984. Suidai Xingyao Yizhi De Faxian He Chubu Fenxi 隋代邢窑遗址的发现和初步分析 [the Discovery and Preliminary Analysis of the Xing Kiln Site of the Sui Dynasty]. *Wenwu 文物* (12):51-57.
- YanYu 雁羽 1960. Jinxi Xigushan Liao Xiaoxiaozhong Mu Qingli Jianbao 锦西孤山辽萧孝忠墓清理简报 [Report on the Cleaning up of Liao Tomb of Xiaoxiaozhong at Xigushan, Jinxi]. *Kaogu 考古* (2):34-35.

- Yap, C. T. & Hua Younan 1994. A Study of Chinese Porcelain Raw Materials for Ding, Xing, Gongxian and Dehua Wares. *Archaeometry* 36 (1):63-76.
- Ye Longli 叶隆礼 (1960-1127)1985. *Qidan Guozhi 契丹国志[Qidan Chronicles]* Jia jingyan and Lin Rong dianjiao ben 贾敬颜、林荣贵点校本 ed. Vol. 24. Shanghai: Shanghai guji chubanshe.
- Ye Maolin 叶茂林 1993. Aohanqi Chutu Ciqi Shang De Manhua 敖汉旗出土瓷器上的漫画 [Cartoon Painting on Ceramics Unearthed at Aohan Banner]. *Wenwu tiandi 文物天地* (2).
- Ye Zhemin 叶喆民 1981. Xingyao Chuyi 邢窑刍议 [a Brief Discussion on Xing Ware]. *Wenwu 文物* (9):49-52.
- Yi Qing'an 易青安 1956. Liaoyang Shi Dalinzi Cun Faxian Shouchang Er Nian Shi Guan 辽阳市大林子村发现寿昌二年石棺 [Stone Coffin of the Second Year of Shouchang Found at Dalinzi Village, Liaoyang City]. *Wenwu cankao ziliao 文物参考资料* (3):79-80.
- Yin Huanliang & Bai Jinsong 殷焕良&白劲松 1997. Chenba'erhu Qi Xiwuzhu'er Gumu Qun Diaocha Qingli Jianbao 陈巴尔虎旗西乌珠尔古墓群调查清理简报 [a Brief Report on Investigation and Clearing up of the Tombs Group at Xiwuzhu'er, Chenba'erhu Banner]. *Hulunbei'er wenwu 呼伦贝尔文物* (4).
- Yin Xiaoyan 尹小燕 1998. Qian'an Faxian Liaodai Muzang 迁安发现辽代墓葬 [Liao Tombs Found at Qian'an]. *Zhongguo wenwu bao 中国文物报*, Jul.15.
- Yu Baodong 于宝东 2006. Liaodai Yuqi Wenhua Yinsu Fenxi 辽代玉器文化因素分析 [Cultural Element Analysis on Liao Jade]. *Neimenggu daxue xuebao (renwen shehui kexue ban) 内蒙古大学学报(人文.社会科学版)* (03).
- Yu Baolin 于宝林 1998. *Qidan Gudai Shi Lun Gao 契丹古代史论稿 [Ancient History of Khitan]*. Hefei: Huanshan shushe.
- Yu Dajun 余大鈞 1987. Yelü Dashi Chuangjian Xiliao Diguó Jíngguó Jì Jinián Xintān 耶律大食創建西遼帝國經過及紀年新探 [Study of Yelü Dashi's Establishment and Dates of the Western Liao Kingdom]. In *Liao Jin Shi Lunji 遼金史論集(一) [Papers on Liao and Jin History]*, edited by 陳. Chen Shu. Shanghai: Shanghai guji chubanshe.
- Yu Guiyun 宇桂云 1979. Liaodai Sancai: Longwen Zhihu He Yuanyang Hu 辽代三彩——龙纹执壶和鸳鸯壶 [Liao Three-Color Glazed Ewers with Dragon Design and Mandarin Duck Shape]. *Zhaomeng wenwu tongxun 昭盟文物通讯* (7).
- Yu Haiyan 于海燕 1992. Chifeng Shi Hongshan Qu Xishuidi Faxian Yizuo Liaomu 赤峰市红山区西水地发现一座辽墓 [a Liao Tomb Found at Xishuidi, Hongshan District, Chifeng]. *Neimenggu wenwu kaogu 内蒙古文物考古* (Z1).

- Yu Junyu et al. 于俊玉等 1993. Chaoyang Fajue Liaodai Daxing Bihua Mu 朝阳发掘辽代大型壁画墓 [a Large Liao Tomb with Mural Paintings Unearthed at Chaoyang]. *Zhongguo wenwu bao 中国文物报*, Jul.18.
- Yu Wenrong 于文荣 1998. Guanyu Liaoci De Chubu Tantaos 关于辽瓷的初步探讨 [a Preliminary Discussion on Liao Ceramics]. *Zhongguo lishi bowuguan guankan 中国历史博物馆馆刊* (02).
- Yu Yongbing 俞永炳 1994. Song Liao Jin Jinian Muzang He Taji Chutu De Ciqi 宋辽金纪年墓葬和塔基出土的瓷器 [Ceramics Unearthed from Datable Tombs and Pagodas of Song, Liao and Jin Dynasty]. *Kaogu 考古* (1).
- Yu 瑜 1992. Heilongjiang Tailai Faxian Liaodai Zhuanshi Mu 黑龙江泰来发现辽代砖室墓 [Liao Tomb with Brick Chamber Found at Tailai, Heilongjiang]. *Beifang wenwu 北方文物* (04).
- Yuan Haibo 袁海波 1985. Liaoning Fuxin Xian Baiyudu Liao Mu 辽宁阜新县白玉都辽墓 [Liao Tomb at Baiyudu, Fuxin, Liaoning]. *Kaogu 考古* (10):958-959,956.
- 2000. Fuxin Faxian Wu Mu Men Liao Mu 阜新发现无墓门辽墓 [Liao Tomb without Gate Found at Fuxin]. In *Fuxin Liao Jin Shi Yanjiu 阜新辽金史研究*. Beijing: Zhongguo shehui chubanshe.
- Yuba Tadanori 弓場紀知 1995. *Chugoku No Toji 03: Sansai 中国の陶磁 03: 三彩 [Chinese Ceramics 03: Three-Color Glaze]*. Tokyo.
- Yun Wei et al. 芸微等 1987. Heilong Jiang Pan De Kalun Shan Gu Muzang Qun 黑龙江畔的卡伦山古墓葬群 [Ancient Tombs Group at Kalun Hill Beside the River Bank of Heilongjiang]. *Heihe xuekan 黑河学刊* (4).
- Yun Wei 芸微 1984. Heilongjiang Zhaoyuan Chutu Liao Jin Ciqi 黑龙江肇源出土辽金瓷器 [Liao and Jin Ceramics Unearthed at Zhaoyuan, Heilongjiang]. *Heilongjiang wenwu congkan 黑龙江文物丛刊* (4).
- Yun Xizheng & Xu Chunling 雲希正&徐春苓 2002. Liaosong Liao Jin Yuqi Bijiao Yanjiu 两宋辽金玉器比较研究 [a Comparative Study of Jades of Northern and Southern Song and Liao-Jin Dynasties]. In *Zhongguo Sui Tang Zhi Qing Dai Yuqi Xueshu Yantaohui Lunwen Ji 中国隋唐至清代玉器学术研讨会论文集 [Symposium on Chinese Jade from Sui and Tang to Qing Dynasties]*. Shanghai: Shanghai guji chubanshe.
- Yun Yao 云瑶 1991. Heilongjiang Sheng Daqing Shi Shajiyao Faxiang De Liaodai Muzang 黑龙江省大庆市沙家窑发现的辽代墓葬 [Liao Tombs Found at Daqing City, Heilongjiang Province]. *Beifang wenwu 北方文物* (02).
- Zeng Yu 曾堉 1984. Yu Long Bian 鱼龙变 [Fish-Dragon Transformation]. *Gugong wenwu yuekan 故宫文物月刊* 2 (3):33-36.

- 1986. Liaochao De Zuo Long 遼朝的坐龍 [Recumbent Dragons of the Liao Dynasty]. *Gugong wenwu yuekan 故宮文物月刊 The National Palace Museum Monthly of Chinese Art* (4):107-10.
- Zhang Baizhong 张柏忠 1983. Kezouhouqi Husinao Qidan Mu 科左后旗呼斯淖契丹墓 [a Qidan Tomb at Husinao, Kezuohouqi]. *Wenwu 文物* (9):18-22.
- 1984. Qidan Zaoqi Wenhua Tansuo 契丹早期文化探索 [an Examination of the Culture of the Early Qidan]. *Kaogu 考古* (2):183-186.
- 1985. Neimonggu Tongliao xian Erlin chang Liaomu 內蒙古通遼縣二林場遼墓 [Liao Tombs at Erlin chang, Tongliao County, Inner Mongolia]. *Wenwu 文物* (3):pp. 56-62.
- Zhang Bingren 张秉仁 1962. Datong Chengdong Majiabao Faxian Yizuo Liao Bihuamu 大同城东马家堡发现一座辽壁画墓 [a Liao Tomb with Mural Paintings Has Been Discovered at Majiabao, East of Datong City]. *Wenwu 文物* (2):57.
- 1963. Shanxi Datong Wohuwan Sizuo Liaodai Bihuamu 山西大同卧虎湾四座辽代壁画墓 [Four Liao Tombs with Mural Paintings at Datong, Shanxi]. *Kaogu 考古* (8):432-436.
- Zhang Fukang 1985. The Origin and Development of Traditional Chinese Glazes and Decorative Ceramic Colors. In *Ancient Technology to Modern Science*, edited by W. D. Kingery and E. Lense. Easton, Pennsylvania: American Ceramic Society.
- Zhang Fukang & Zhang Zhigang 张福康 & 张志刚 1980. Zhongguo Lidai Diwen Seyou He Youshang Cai 中国历代低温色釉和釉上彩 [Low-Temperature Colored Glazes of Successive Dynasties in Ancient China]. *Guisuanyan xuebao* 8 (1):9-19.
- Zhang Fukang et al., Cheng Zhuhai, and Zhang Zhigang 1983. Study on Ancient Chinese Liuli. *Guisuanyan xuebao* 11 (1):67-76.
- Zhang Fukang 张福康 2000. *Zhongguo Gutaoci De Kexue 中国古陶瓷的科学 [the Science of Ancient Chinese Pottery and Porcelain]*. Shanghai: Shanghai Renmin Meishu chubanshe.
- Zhang Guangyuan 張光遠 2000. Minzu Jiaoliu Yu Caoyuan Wenhua: Ba Qian Nian Neimenggu Caoyuan Wenming De Zhanxian 民族交流與草原文化—八千年內蒙古草原文明的展現 Ethnic Exchange and Grassland Culture : the Grassland Civilization of Inner Mongolia 8000 Years. *Gugong wenwu yuekan 故宮文物月刊 The National Palace Museum Monthly of Chinese Art* (6):6-11.
- Zhang Guilian 张桂莲 1996. Liaodai Taoci Fenqi Yanjiu 辽代陶瓷分期研究 [Study on Chronological Classification of Liao Ceramics], Archaeology department, Pekiny university, Beijing.
- 2000. Liao Dai Baici Bianxi 辽代白瓷辨析 [Discuss and Discrimination of Liao White Porcelains]. *Shoucang jia 收藏家* (6).

- Zhang Guoqing & Piao Zhongguo 张国庆 & 朴忠国 1997. *Liaodai Qidan Xisu Shi 辽代契丹习俗史* [History of Liao Qidan Customs]. Shenyang: Liaoning minzu chubanshe.
- Zhang Guoqing & Zhang Yuzhen 张国庆 & 张玉珍 1998. Lun Kaogu Qiwu Mu Shi Bihua Zai Liao Shi Yanjiu Zhong De Yunyong 论考古器物、墓室壁画在辽史研究中的运用 [Discuss on the Application of Archaeological Objects and Mural Paintings on the Study of Liao History]. *Liaoning shifan daxue xuebao(shehui kexue ban) 辽宁师范大学学报(社会科学版)* (3).
- Zhang Guoqing 张国庆 1998. Qidan Zu Wenhua Dui Hanzu Yingxiang Cuyi 契丹族文化对汉族影响刍论 [Discuss on the Cultural Influence of Khitan to Han People]. *Beifang wenwu 北方文物* (03).
- Zhang Hanying & Bai Guang 张汉英 & 白光 1993. Hebei Fengning Xiaopijianggou Faxian Liao Mu 河北丰宁小皮匠沟发现辽墓 [Liao Tombs Found at Xiaopijianggou, Fengning, Hebei]. *Kaogu 考古* (10):957-958.
- Zhang Hanying 张汉英 1996. Hebei Fengning Wudao Goumen Liao Mu 河北丰宁五道沟门辽墓 [Liao Tomb Found at Wudaogoumen, Fengning, Hebei]. *Wenwu chunqiu 文物春秋* (02):18-25.
- Zhang Hongbo & Li Zhi 张洪波 & 李智 1990. Beipiao Quanjuyong Liao Mu Fajue Jianbao 北票泉巨涌辽墓发掘简报 [Excavation of a Liao Tomb in Quanjuyong, Beipiao]. *Liaohai wenwu xuekan 辽海文物学刊* (2):24-28.
- Zhang Jianmin 张建民 2002. Liaodai Sancai Yinhuo Mudan Pan 辽代三彩印花牡丹盘 [Liao Three-Color Glazed Oblong Lobed Dishes]. *Zhongyuan wenwu 中原文物* (05).
- Zhang Jie & Zhu Tao 张杰 & 朱涛 2004. Heilongjiang Sheng Zhaodong Shi Laozhou Zhen Anye Cun Faxian De Liaodai Muzang 黑龙江省肇东市涝洲镇安业村发现的辽代墓葬 [Liao Tombs Found at Anye Village, Laozhou Township, Zhaodong City, Heilongjiang Province]. *Beifang wenwu 北方文物* (01):38-39.
- Zhang Jindong 张金栋 1991. Longhua Xian Liangzigou Liao Mu 隆化县亮子沟辽墓 [Liao Tomb Found at Liangzigou, Longhua]. In *Zhongguo Kaogu Xue Nianjian (1990 Nian) 中国考古学年鉴 (1990年)*. Beijing: Wenwu chubanshe.
- Zhang Jingai 景爱 1982. Liaojin Shidai De Huo Zang Mu 辽金时代的火葬墓 [Cremated Tombs of Liao and Jin Dynasty]. In *Dongbei Kaogu Yu Lishi 东北考古与历史*. Beijing Wenwu chubanshe.
- 1990. Liaodai Nüzhen Ren Yu Gaoli De Guanxi 辽代女真人与高丽的关系 [the Relationship between Jurchen and Goryeo in Liao Dynasty]. *Beifang wenwu 北方文物* (03).
- Zhang Jingming & Ma Liqing 张景明 & 马利清 1999. Lun Liaodai Zao Zhong Qi Jin Yin Qi De Tangdai Fengge 论辽代早中期金银器的唐代风格 [Discuss on the Tang Style Factors on

- the Gold and Silver Wares of Early and Middle Liao Dynasty]. *Neimenggu daxue xuebao (renwen shehui kexue ban)* 内蒙古大学学报(人文·社会科学版) (05).
- Zhang Jingming & Zhao Aijun 张景明 & 赵爱军 1997. Liaodai Jin Yin Qi Gaishu 辽代金银器概述 [Summary on Gold and Silver Wares of Liao Dynasty]. In *Ji Wang Kai Lai: Neimenggu Bowuguan Wen Ji 继往开来——内蒙古博物馆文集*. Huhehaote: Neimenggu renmin chubanshe.
- 2000. Liaodai Jin Yin Qi De Qixing Wenshi Yanbian Ji Gongyi 辽代金银器的器形纹饰演变及工艺 [Technique and Evolution of the Forms and Decorations of Liao Gold and Silver Wares]. *Beifang wenwu 北方文物* (1):39-45.
- 2001. Shilun Liaodai Jin Yin Qi 论辽代金银器 [Discuss on Liao Gold and Silver Wares]. *Kaogu yu wenwu 考古与文物* (02).
- Zhang Jingming 张景明 2005. *Zhongguo Beifang Caoyuan Gudai Jinyin Qi 中国北方草原古代金银器 [Chinese Ancient Gold and Silver Wares of Northern Steppe]*. Peking: Wenwu chubanshe.
- 2006a. Liao Dai Jin Yin Qi De Tezheng Ji Zaoxing Yishu 辽代金银器的特征及造型艺术 [Formative Art and Characteristic of the Gold and Silver Wares of Liao Dynasty]. *Dalian daxue xuebao 大连大学学报* (01).
- 2006b. Liao Dai Jin Yin Qi Zhong Zhi Xifan Wenhua He Song Wenhua De Yinsu 辽代金银器中之西方文化和宋文化的因素 [Factors of Song Culture and Western Culture on the Gold and Silver Wares of Liao Dynasty]. *Neimenggu daxue yishu xueyuan xuebao 内蒙古大学艺术学院学报* (01).
- Zhang Keju 张克举 1989. Beizhen Xian Longgang Liao Mu 北镇县龙岗辽墓 [Liao Tombs at Longgang, Beizhen]. In *Zhongguo Kaogu Xue Nianjian (1988 Nian) 中国考古学年鉴 (1988年)*. Beijing Wenwu chubanshe.
- Zhang Keju 张克举, and Liaoningsheng wenwu kaogu yanjiusuo 辽宁省文物考古研究所 1995. Liaoning Chaoyang Mutouchengzi Liaodai Bihua Mu 辽宁朝阳木头城子辽代壁画墓 [Liao Tombs with Mural Paintings at Mutouchengzi, Chaoyang, Liaoning]. *Beifang wenwu 北方文物* (02):31-34.
- Zhang Luzi 张绿子 1958. Liaodai Shike Mudan Tuan 辽代石刻牡丹图案 [Peony Designs on Liao Stone Carvings]. *Wenwu 文物* (11):30-31.
- Zhang Pingyi 张平一 1956. Pingquanxian Faxian Liaodai Bihuamu 平泉县发现辽代壁画墓 [Liao Tombs with Mural Painting Have Been Discovered at Pingquan County]. *Wenwu 文物* (10):74.
- Zhang Pusheng & Huo Hua 张浦生 & 霍华 1996. Liaoci Xinshuo 辽瓷新说 [New Opinions on Liao Ceramics]. *Shoucang jia 收藏家* (3).

- Zhang Shaoqing 张少青 1986. Liaoning Kangping Xian Hou Liudong Tun Liao Mu 辽宁康平县后刘东屯辽墓 [Liao Tombs at Houliudongtun, Kangping, Liaoning]. *Kaogu 考古* (10):922-925.
- 1988a. Liaoning Kangping Faxian De Qidan Liao Mu Gaishu 辽宁康平发现的契丹、辽墓概述 [Summary of Liao and Khitan Tombs Found at Kangping, Liaoning]. *Beifang wenwu 北方文物* (04).
- 1988b. Liaoning Kangping Xian Hou Liudongtun 2 Hao Liaomu 辽宁康平县后刘东屯二号辽墓 [Liao Tomb at Houliudongtun, Kangping, Liaoning]. *Kaogu 考古* (9):819-824, 813.
- Zhang Songbai & Song Guojun 张松柏 &宋国军 1991. Chengzi Jin Yin Qi Yanjiu 城子金银器研究 [Research on the Gold and Silver Objects from Chengzi]. In *Neimenggu Dongbu Qu Kaogu Xue Wenhua Yanjiu Wenji 内蒙古东部区考古学文化研究文集 [Essay on Archaeological and Cultural Research in the Eastern Region of Inner Mongolia]*. Beijing Haiyang chubanshe.
- Zhang Songbai 张松柏 1993. Erbadi Chutu De Yisilan Jin Yin Qi Yanjiu 二八地出土的伊斯兰金银器研究 [Study on Islamic Gold and Silver Wares Found at Erbadi]. *Bowuguan yanjiu 博物馆研究* (3).
- 1994. Xiyu Xunshou Dui Liaodai De Yingxiang Jiqi Zai Liaojing De Chuanbo 西域驯兽对辽代的影响及其在辽境的传播 [Influence and Spreading of the Animal Taming Custom of Western Regions to Liao Dynasty]. *Neimenggu wenwu kaogu 内蒙古文物考古* (1).
- 1995. Lun Liaoci Jiguanhu 论辽瓷鸡冠壶 [Discuss on Bag-Shaped Pilgrim Flasks of Liao Dynasty]. *Meishu shilun 美术史论* (1).
- 1997. Guanyu Jiguanhu Yanjiu Zhong De Jige Wenti 关于鸡冠壶研究中的几个问题 [Several Issues Concerning the Research on Cockscomb Flasks]. In *Neimenggu Wenwu Kaogu Wenji(2) 内蒙古文物考古文集(2)[Essays on the Archaeology of Cultural Relics in Inner Mongolia(2)]*, edited by Wei Jian 魏坚 (Neimenggu wenwu kaogu yanjiusuo 内蒙古文物考古研究所). Beijing: Zhongguo dabaiké quanshu chubanshe.
- Zhang Wenyi & Dong Li 张文毅&董丽 1997. Qidan Wenhua Yishu Fengge Xiguan De Hanhua 契丹文化艺术风俗习惯的汉化 [Chinese Localization of the Cultural and Artistic Custom of Khitan People] *Liaoning daxue xuebao (zhexue sheihui kexue ban) 辽宁大学学报(哲学社会科学版)* (02).
- Zhang Xiande 张先得 1980. Beijingshi Daxingxian Liaodai Ma Zhiwen Fufu Hezangmu 北京市大兴县辽代马直温夫妇合葬墓 [the Liao Tomb of the Ma Zhiwen Couple at Daxing, Beijing]. *Wenwu 文物* (12):30-37.
- Zhang Xirong 张喜荣 1993. Liaoning Anshan Shi Yang'eryu Liaodai Huaxiangshi Mu 辽宁鞍山市羊耳峪辽代画像石墓 [Liao Tomb with Portrait Stone at Yang'eryu, Anshan, Liaoning]. *Kaogu 考古* (3).

- Zhang Xiufu et al. 张秀夫等 1982. Hebei Pingquan Xian Xiaojigou Liao Mu 河北平泉县小吉沟辽墓 [a Liao Tomb at Xiaojigou, Pingquan County, Hebei]. *Wenwu 文物* (7):50-53.
- Zhang Yanqiu & A Shalan 张艳秋 & 阿沙兰 1994. Liao Sancai Yu Tang Sancai Yitong Lun 辽三彩与唐三彩异同论 [Discuss on Differences and Similarities of Liao Three-Color Glazed Ceramics with Tang Ones]. *Songzhou xuekan 松州学刊* (6).
- Zhang Yu 张郁 1959. Neimenggu Liao Zhongjing Ji Xicheng Wai Chutu De Wenwu 内蒙辽中京及西城外出土的文物 [Relics Unearthed at Liao Central Capital and Outside Its Western City]. *Kaogu 考古* (7).
- 1961. Wulanchabumeng Youqianqi Gumu Qingliji 乌兰察布盟右前旗古墓清理记 [a Report of the Cleaning up of Liao Tombs at Youqianqi, Wulanchabumeng]. *Wenwu 文物* (9):58-61.
- 1991. Caoyuan Sichou Zhi Lu: Qidan Yu Xiyu 草原丝绸之路——契丹与西域 [Steppe Silk Road: Khitan and Western Regions]. In *Neimenggu Dongbu Qu Kaogu Xue Wenhua Yanjiu Wenji 内蒙古东部区考古学文化研究文集*. Beijing Haiyang chubanshe.
- 1997. Liao Shangjing Chengzhi Kancha Suoyi 辽上京城址勘查琐议 [Notes on the Excavation of Remains of the Liao City of Shangjing]. In *Neimenggu Wenwu Kaogu Wenji 内蒙古文物考古文集 [Essays on the Archaeology of Cultural Relics in Inner Mongolia]*, edited by Wei Jian 魏坚. Beijing: Zhongguo da baike quanshu chubanshe.
- Zhang Zhaoxiang & Wu Yuru 张兆祥 & 武玉茹 1997. Langfang Shi Chutu Liaodai Baici Yanjiu 廊坊市出土辽代白瓷研究 [Study on the White Porcelains Unearthed from Langfang City]. *Wenwu chunqiu 文物春秋* (Z1):61-63.
- Zhang Zhaoxiang 张兆祥 1989. Xianghe Xian Qiyin Si Ta Nei Faxian Liaodai Ciqi 香河县栖隐寺塔内发现辽代瓷器 [Liao Ceramics Found at Pagoda of Qiyin Temple in Xianghe County]. *Wenwu chunqiu 文物春秋* (Z1):137.
- 2004. Xianghe Liao Dai Ditong Faxian De Baici Gongju 香河辽代地宫发现的白瓷贡具 [White Porcelains of Tribute Vessels Found at the Underground Chamber of Liao Pagoda at Xianghe]. *Shoucang jie 收藏界* (10).
- Zhang Zhengming 张正明 1979. *Qidan Shilue 契丹史略 [a Brief History of the Qidan]*. Beijing: Zhonghua shuju.
- Zhangjiakou diqu wenhuaju 张家口地区文化局 1987. Hebei Zhangbei Xian Qingli Yi Zuo Liaodai Bihua Mu 河北张北县清理一座辽代壁画墓 [Clearing up of a Liao Tomb with Mural Painting at Zhangbei County, Hebei]. *Kaogu 考古* (1):93.
- Zhangwu xian wenwu guanlisuo 彰武县文物管理所 2000. Zhangwu Gaocheng Liao Mu Qingli Jianbao 彰武高成辽墓清理简报 [a Brief Report of Clearing up of Liao Tomb of Gaocheng at Zhangwu]. In *Fuxin Liao Jin Shi Yanjiu 阜新辽金史研究*. Beijing: Zhongguo shehui chubanshe.

- Zhao Fangzhi 1995. *Caoyuan Wenhua 草原文化 [Grassland Culture]*. Shanghai: Shangwu Yinshu Guan.
- Zhao Guangli 赵光林 1993. Cong 'Shouchang Wu' Jinian Kuan Sancai Canpian Niandai Kan Longquanwu Yao De Shaozhi Niandai Ji Xingzhi 从“寿昌五”纪年款三彩残片年代看龙泉务窑的烧制年代及性质 [Discuss on Dating and Property of the Longquanwu Kiln Site from the View of a Three-Color Glazed Shard with a Datable Inscription of the Year of the Fifth Year of Shouhang]. *Beijing wenwu bao 北京文物报* (10).
- Zhao Guanglin & Zhang Ning 赵光林 & 张宁 1979. Jindai Ciqi De Chubu Tansuo 金代瓷器的初步探索 [a Preliminary Survey of Jin Ceramics]. *Kaogu 考古* (5):461-471.
- Zhao Guanglin et al. 赵光林等 1993a. Beijing Diqu Gu Yaozhi (Shang) 北京地区古窑址 (上) [Ancient Kiln Sites in Beijing Region]. *Hebei taoci 河北陶瓷* (5).
- 1993b. Beijing Diqu Gu Yaozhi (Xia) 北京地区古窑址 (下) [Ancient Kiln Sites in Beijing Region]. *Hebei taoci 河北陶瓷* (6).
- Zhao Guanglin 赵光林 1978. Miyun Xiaoshuiyu Cun Faxian Liao Jin Yaozhi 密云小水峪村发现辽金窑址 [Liao and Jin Kiln Sites Found at Xiaoshuiyu Village of Miyun County]. *Beijing ribao 北京日报*, July 8.
- 1981. Beijing Miyun Xiaoshuiyu Cun Faxian Liao Jin Ciyao 北京密云小水峪村发现辽金瓷窑 [Liao and Jin Kiln Sites Found at Xiaoshuiyu Village of Miyun County in Beijing]. *Wenwu 文物* (8).
- 1984a. Jinnian Beijing Faxian De Jichu Gudai Ciyao Zhi 近年北京发现的几处古代瓷窑址 [Several Ancient Kiln Sites Found in Beijing in Recent Years]. In *Zhongguo Gudai Yaozhi Diaocha Fajue Baogao Ji 中国古代窑址调查发掘报告集*, edited by 文. Wenwu bianji weiyuanhui. Beijing: Wenwu chubanshe.
- 1984b. Mentougou Qu Longquanwu Liao Sancai Chandi 门头沟区龙泉务辽三彩产地 [One Production Place of Liao Three-Color Galzed Ceramics in Longquanwu, Mentougou] In *Zhongguo Kaogu Xue Nianjian (1984 Nian) 中国考古学年鉴 (1984 年)*. Beijing: Wenwu chubanshe.
- 1986. Jinnian Beijing Diqu Faxian De Jichu Gudai Liuli Yaozhi 近年北京地区发现的几处古代琉璃窑址 [Several Liuli Kiln Sites Found in Beijing Region in Recent Years]. *Kaogu 考古* (7):628-31.
- 1996. Liao Huang Lü You Jiguanhu 辽黄绿釉鸡冠壶 [Yellow and Green Glazed Bag-Shaped Pilgrim Flasks of Liao Dynasty]. *Beijing wenwu bao 北京文物报*.
- Zhao Guodong et al. 赵国栋等, and 赤峰市博物馆 & 宁城县文管所 1997. Neimenggu Chifengshi Ningcheng Tiejiangyingzi Zhuanchang Liaomu 内蒙古赤峰市宁城县铁匠营子砖厂辽墓 [Liao Tombs at Tiejiangyingzi Zhuanchang, Ningcheng, Chifeng, Inner Mongolia]. *Neimenggu wenwu kaogu 内蒙古文物考古* (1):68-72.

- Zhao Lianji 赵连季 2000. Liaodai Huangyou Juhua Zhen 辽代黄釉菊花枕 [Yellow Glazed Pillow of Liao Dynasty]. *Neimenggu wenwu kaogu* 内蒙古文物考古 (02).
- Zhao Mingxing 赵明星 2004. Lun Jiguanhu Shang De Su Hou Xisu 论鸡冠壶上的塑猴习俗 [Discuss on the Custom of Sculpting Monkey on Bag-Shaped Pilgrim Flasks]. *Beifang wenwu* 北方文物 (03):29-35.
- Zhao Tie 赵铁 1988. Lishu Fujiazi Shan Liaomu Qingli Jianbao 梨树孤家子山辽墓清理简报 [a Brief Report on Clearing up of Liao Tombs at Gujiazi Hill of Lishu]. *Bowuguan yanjiu* 博物馆研究 (1).
- Zhao Wengang 赵文刚 1992. Tianjin Shi Ji Xian Yingfang Cun Liao Mu 天津市蓟县营房村辽墓 [Liao Tomb in Yingfang Village, Jixian, Tianjin]. *Beifang wenwu* 北方文物 (03):36-41.
- Zhao Wenjun 赵文军 1996. Henan Tang Sancai Song San Cai Yu Liao Sancai 河南唐三彩、宋三彩与辽三彩 [Tand Three-Color Glazed Ceramics and Song and Liao Ones]. In *Henan Wenwu Kaogu Lunji* 河南文物考古论集. Zhengzhou: Henan renmin chubanshe.
- Zhao Xin 赵信 1963. Neimenggu Zhaomeng Balin Zuoqi Shuangjinggou Liao Huozang Mu 内蒙古昭盟巴林左旗双井沟辽火葬墓 [Liao Cremated Tombs at Shuangjinggou, Balin Left Banner, Zhaowuda Union, Inner Mongolia]. *Kaogu* 考古 (10).
- Zhao Xin 赵欣 1990. Zhangjiakou Shi Xiahuayuan Faxian Yizuo Liaodai Mu 张家口市下花园发现一座辽代墓 [a Liao Tomb Found at Xiahuayuan, Zhangjiakou City]. *Wenwu chunqiu* 文物春秋 (1):92-93.
- Zhao Zhensheng & Bai Jie 赵振生&白杰, and Fuxin shi bowuguan choubeyichu 阜新市博物馆筹备处 1995. Liaoning Fuxin Xian Qidan Liao Mu De Qingli 辽宁阜新县契丹辽墓的清理 [Clearing up of Liao Tombs of Khitan People at Fuxin, Liaoning]. *Kaogu* 考古 (11):1008-1012.
- Zhao Zhensheng & Yu Zemin 赵振生&于泽民 1997. Fuxin Liaomu Sangzang Xisu Ji Mushi Jiegou Xingzhi De Yanjiu 阜新辽墓丧葬习俗及墓室结构形制的研究 [Study on the Burial Customs and the Structural Shapes of Liao Tombs at Fuxin]. *Fuxin gaozhuan xuebao* 阜新高专学报 (3).
- Zhao Zhihou & Ma Qingpeng 赵志厚&马清鹏 1996. Hebei Luanping Xian Xigou Xiang Faxia Liaodai Wenwu 河北滦平县西沟乡发现辽代文物 [Liao Relics Found at Xigou Township, Luanping County, Hebei]. *Wenwu chunqiu* 文物春秋 (01).
- Zhao Zhihou 赵志厚 1982. Liaodai Baiyou Fengshouhu He Lüyou Madenghu 辽代白釉凤首壶和绿釉马镫壶 [a White-Glazed Phoenix-Head Ewer and a Green-Glazed Bag-Shaped Pilgrim Flask]. *Wenwu tiandi* 文物天地 (4):43.
- 1991. Luanping Xian Yinwogou Zhuanshi Mu Qingli Jianbao 滦平县银窝沟砖室墓清理简报 [a Brief Report of Clearing up of Liao Tomb with Brick Chamber at Yinwogou, Luanping]. *Wenwu chunqiu* 文物春秋 (4).

- Zhaowudameng wenwu gongzuozhan 昭乌达盟文物工作站 1980. *Zhaowudameng Wenwu Xuanji 昭乌达盟文物选集 [Selected Relics Unearthed at Zhaowudameng]*. Zhaomeng: Neimenggu renmin chubanshe.
- Zhejiangsheng bowuguan & Hangzhoushi wenguanhui 浙江省博物馆 & 杭州市文管会 1979. Zhejiang Linan Wantang Qian Kuan Mu Chutu Tianwentu Ji Guan Zikuan Baici 浙江临安晚唐钱宽墓出土天文图及官字款白瓷 [an Astronomical Picture and Some Guan-Marked White Wares Have Been Unearthed from the Late Tang Tomb of Qian Kuan at Linan, Zhejiang]. *Wenwu 文物*.
- Zhelimumeng bowuguan et al. 哲里木盟博物馆等 1982. Kuluqi Di Wu Liu Hao Liao Mu 库伦旗第五六号辽墓 [Liao Tombs and at Kulunqi]. *Neimenggu wenwu kaogu 内蒙古文物考古* (2):35-46.
- Zhelimumeng bowuguan 哲里木盟博物馆 1984. Neimenggu Zhelimumeng Faxian De Jizuo Qidanmu 内蒙古哲里木盟发现的几座契丹墓 [Several Qidan Tombs Discovered at Zhelimumeng, Inner Mongolia]. *Kaogu 考古* (2):153-156.
- Zheng Chuanshui 郑川水 2003. Liao Shengzong Ji Liao Yu Gaoli Fanjiao Kaolue 辽圣宗及辽与高丽藩交考略 [Research on Liao Emperor Shengzong and the Relationship between Liao and Goryeo]. *liaoning daxue xuebao (zhexue sheihui kexue ban) 辽宁大学学报(哲学社会科学版)* (01).
- Zheng Long 郑隆 1959. Chifeng Dawopu Faxian Yizuo Liaomu 赤峰大窝铺发现一座辽墓 [a Liao Tomb Has Been Discovered at Dawopu, Chifeng]. *Kaogu 考古* (1):47-48.
- 1961. Zhaowudameng Liao Shangwei Fu Mu Qingli Jianbao 昭乌达盟辽尚晖符墓清理简报 [a Brief Report of the Cleaning up of the Liao Tomb of Shang Weifu at Zhaowudameng]. *Wenwu 文物* (9):50-51.
- 1981a. Neimenggu Zhelimumeng Nailingao Liaodai Bihuamu 内蒙古哲里木盟奈林稿辽代壁画墓 [Liao Tombs with Mural Paintings at Nailingao, Zhelimumeng, Inner Mongolia]. In *Kaoguxue Jikan 考古学集刊*, edited by kaogu bianjibu. Beijing: Zhongguo shehui kexue chubanshe.
- 1981b. Zhunge'er Qo Dashata Bihua Mu Ji Fujin De Gu Cheng 准格尔旗大沙塔壁画墓及附近的古城 [a Tomb with Mural Painting and the Ancient City Nearby at Dashata, Zhunge'er Banner] *Neimenggu wenwu kaogu 内蒙古文物考古* (1):95-101.
- Zheng Shaozong 郑绍宗 1956. Chifeng Dayingzi Liaomu Fajue Baogao 赤峰大营子辽墓发掘报告 [a Report of the Excavations of Liao Tombs at Dayingzi, Chifeng]. *Kaogu xuebao 考古学报* (3):1-26.
- 1989. Xuanhua Liaomu Bihua Yanjiu 宣化辽墓壁画研究 [Study on Liao Tombs with Mural Paintings at Xuanhua]. In *Liao Jin Shi Lun Ji 辽金史论集*, edited by Zhongguo liaojin shi xuehui. Beijing: Shumu wenxian chubanshe.

- 1993. Zhangjiakou Shi Qingli Liao Bihua Mu Qun 张家口市清理辽壁画墓群 [Clearing up of Liao Tombs with Mural Paintings at Zhangjiakou Xity]. *Zhongguo wenwu bao 中国文物报*, Aug.8.
- 1994. Hebei Xuanhua Liaomu Bihua Chadao Tu De Yanjiu 河北宣化辽墓壁画茶道图的研究 [Study on the Tea Ceremony Motif on Mural Paintings of Liao Tombs at Xuanhuan, Hebei]. *Nongye kaogu 农业考古* (02).
- 1995. Liaodai Huihua Yishu He Liaomu Bihua De Faxianyu Yanjiu 辽代绘画艺术和辽墓壁画的发现与研究 [Art of Liao Painting and the Discovery and Study on Mural Paintings in Liao Tombs]. *Wenwu chunqiu 文物春秋* (2):39-51.
- 1996. Hebei Xuanhua Liao Zhangwenzao Bihua Mu Fajue Jianbao 河北宣化辽张文藻壁画墓发掘简报 [a Brief Report on Excavation of Liao Tomb with Mural Painting of Zhang Wenzao at Xuanhua, Hebei]. *Wenwu 文物* (09):14-46.
- Zheng xiuqin 郑秀琴 2000. Laofu Xishan Qidan Mu Qingli Jianbao 老府西山契丹墓清理简报 [a Brief Report of Clearing up of Khitan Tomb at Xishan, Laofu]. *Zhaowuda meng mengzu shizhuan xuebao 昭乌达蒙族师专学报* (02).
- Zhenjiangshi bowuguan 镇江市博物馆 1977. Zhenjiang Jurong Chutu De Jijian Wudai Beisong Ciqu 镇江句容出土的几件五代北宋瓷器 [Several Pieces of Five Dynasties and Northern Song Ceramics Unearthed at Jurong, Zhenjiang]. *Wenwu 文物* (10):90-92.
- Zhongguo guisuanyan xuehui 中国硅酸盐学会 1982. *Zhongguo Gu Taoci Lunwen Ji 中国古陶瓷论文集 [Collected Essays on Ancient Chinese Ceramics]*. Edited by Zhongguo guisuanyan xuehui 中国硅酸盐学会. Beijing.
- 1984. *Zhongguo Taoci Shi 中国陶瓷史 [a History of Chinese Ceramics]*. Edited by 中. Zhongguo guisuanyan xuehui. Beijing: Wenwu chubanshe.
- Zhongguo shehui kexueyuan kaogu yanjiusuo 中国社会科学院考古研究所 1961. *Xinzhongguo De Kaogu Shouhuo 新中国的考古收获 [the Archaeological Gains of New China]*. Edited by 中. Zhongguo kexueyuan kaogu yanjiusuo. Beijing: Wenwu chubanshe.
- 1984. *Xinzhongguo De Kaogu Faxian He Yanjiu 新中国的考古发现和研究 [Archaeological Finds and Study in New China]*. Beijing: Wenwu chubanshe.
- Zhongguo shekeyuan neimenggu gongzuodui et al. 内蒙古文物考古研究所等 2003. Neimenggu Zhalute Qi Haotehua Liaodai Bihua Mu 内蒙古扎鲁特旗浩特花辽代壁画墓 [Liao Tomb with Mural Painting at Haotehua, Zhalute Banner, Inner Mongolia]. *Kaogu 考古* (1):3-14.
- Zhongguo taoci quanji bianji weiyuanhui 中国陶瓷全集编辑委员会 1999. *Zhongguo Taoci Quanji 9: Liao Xi Xia Jin 中国陶瓷全集9. 辽西夏金 [the Complete Works of Chinese Ceramics Vol. 9: Liao, Western Xia and Jin]*. Edited by Zhongguo tao ci quan ji bian ji wei yuan hui. Shanghai: Shanghai renmin meishu chubanshe.

- zhonghua shiji tan & Neimenggu bowuguan 2004. *Chengjisihan: Zhongguo Gudai Beifang Caoyuan Youmu Wenhua 成吉思汗：中国古代北方草原游牧文化 [Genghis Khan-the Ancient Nomadic Culture of the Northern China]*. Edited by I. M. A. R. M. 内蒙古自治区博物馆 and B. w. a. m. 中华世纪坛艺术馆. Beijing: Beijing chubanshe.
- Zhou Guochen 朱国忱 1955. Heilongjiang Zhujiakan Zhen Faxian Liaomu 黑龙江朱家坎镇发现辽墓 [Liao Tombs Found at Zhujiakan Township, Heilongjiang]. *Kaogu tongxun 考古通讯* (2).
- Zhou Xinhua 周新华 2000. Xuanhua Liaomu Bihua Suojian Zhi Chaju Kao 宣化辽墓壁画所见之茶具考 [Research on the Tea Ceremony Vessels Seen on the Mural Painting of Liao Tombs at Xuanhua]. *Dongnan wenhua 东南文化* (07).
- Zhu Ruixi et al. 朱瑞熙等 1998. *Liao Song Xixia Jin Shehui Shenghuo Shi 辽宋西夏金社会生活史 [Social History Of the Liao, Song, Western Xia and Jin]*. Beijing: Zhongguo shehui kexue chubanshe.
- Zhu Tianshu 朱天舒 1997. Liaodai Jin Yin Qi Shang De Feng Wen 辽代金银器上的凤纹 [Phoenix Motif on Gold and Silver Wares of Liao Dynasty]. *Neimenggu wenwu kaogu 内蒙古文物考古* (1):33-36.
- 1998. *Liao Dai Jin Yin Qi 辽代金银器 [Liao Gold and Silver Wares]*. Beijing: Wenwu chubanshe.
- Zhu Zhigang 朱志刚 2004. Haidian Zhongguo Gongyu Nxueyuan Liaomu Jiqi Muzhi 海淀中国工运学院辽墓及其墓志 [Liao Tomb at Collage of Zhongguo Gongyun at Haidian and Its Epitaph]. In *Beijing Wenwu Yu Kaogu 北京文物与考古*. Beijing: Minzu chubanshe.
- Zhu Zifang & Xu Ji 1983. Liaoning Chaoyang Guyingzi Liao Geng Shi Mu Fajue Baogao 辽宁朝阳姑营子辽耿氏墓发掘报告 [Report on the Geng Family Tombs of the Liao in Guyingzi, Chaoyang, Liaoning]. In *Kaoguxuejikan 考古学集刊*. Beijing: Zhongguo Shehui kexue chubanshe.
- Zhu Zifang 朱子方 1963. Liao Ci Suo Tan 辽瓷琐谈 [Discuss on Liao Ceramics]. *Da gong bao 大公报*, May.12.
- Zou Xiangqian 邹向前 1995. Heilongjiang Sheng Longjiang Xian Luhe Xinfeng Zhuan Chang Liao Mu 黑龙江省龙江县鲁河新丰砖厂辽墓 [Liao Tombs at Xinfeng Zhuanchang, Luhe, Longjiang County, Heilongjiang]. *Beifang wenwu 北方文物* (02).

MAPS

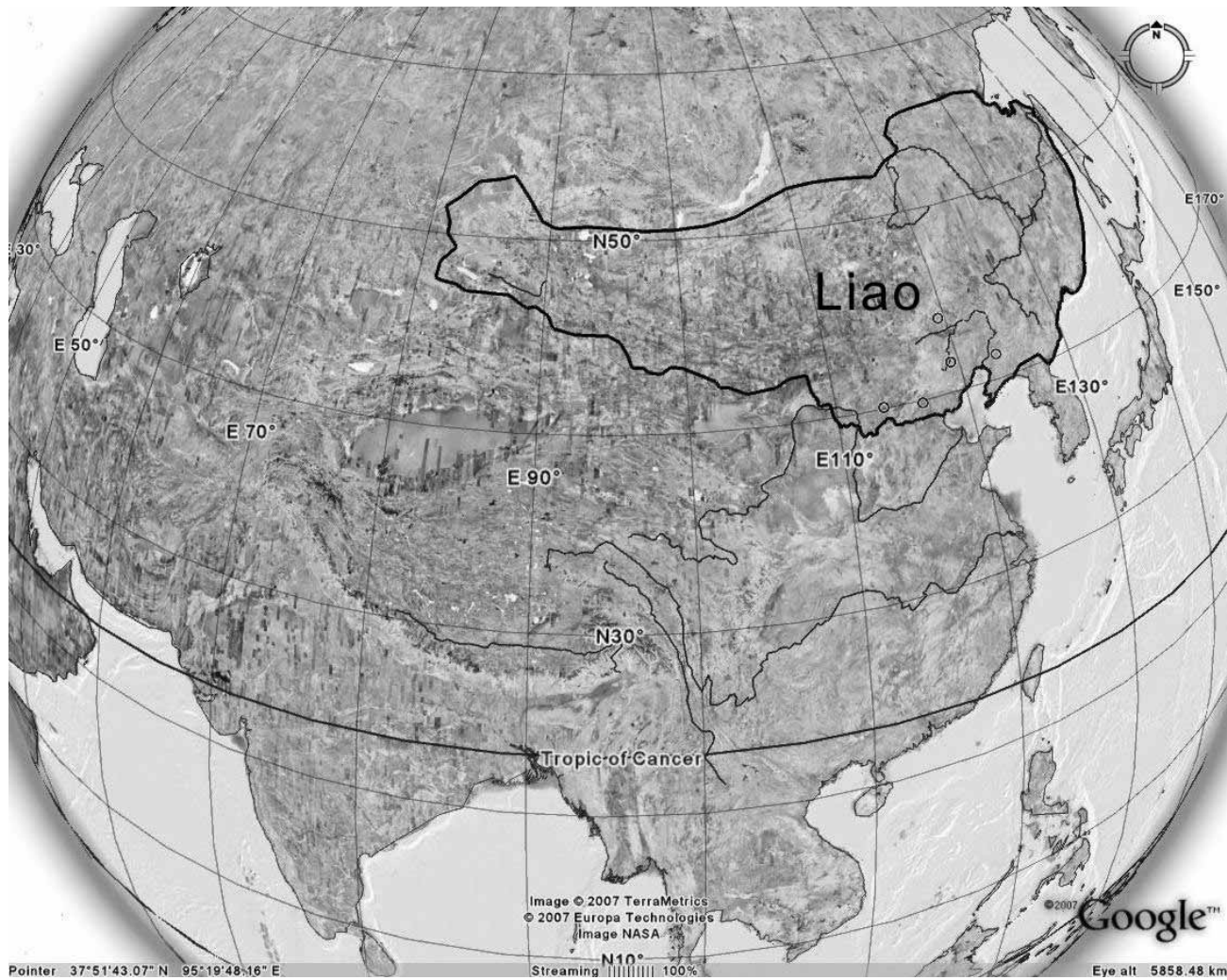

Map 1: Liao empire, Ca. 1111 AD (google map, after Tan Qixiang, 1982)

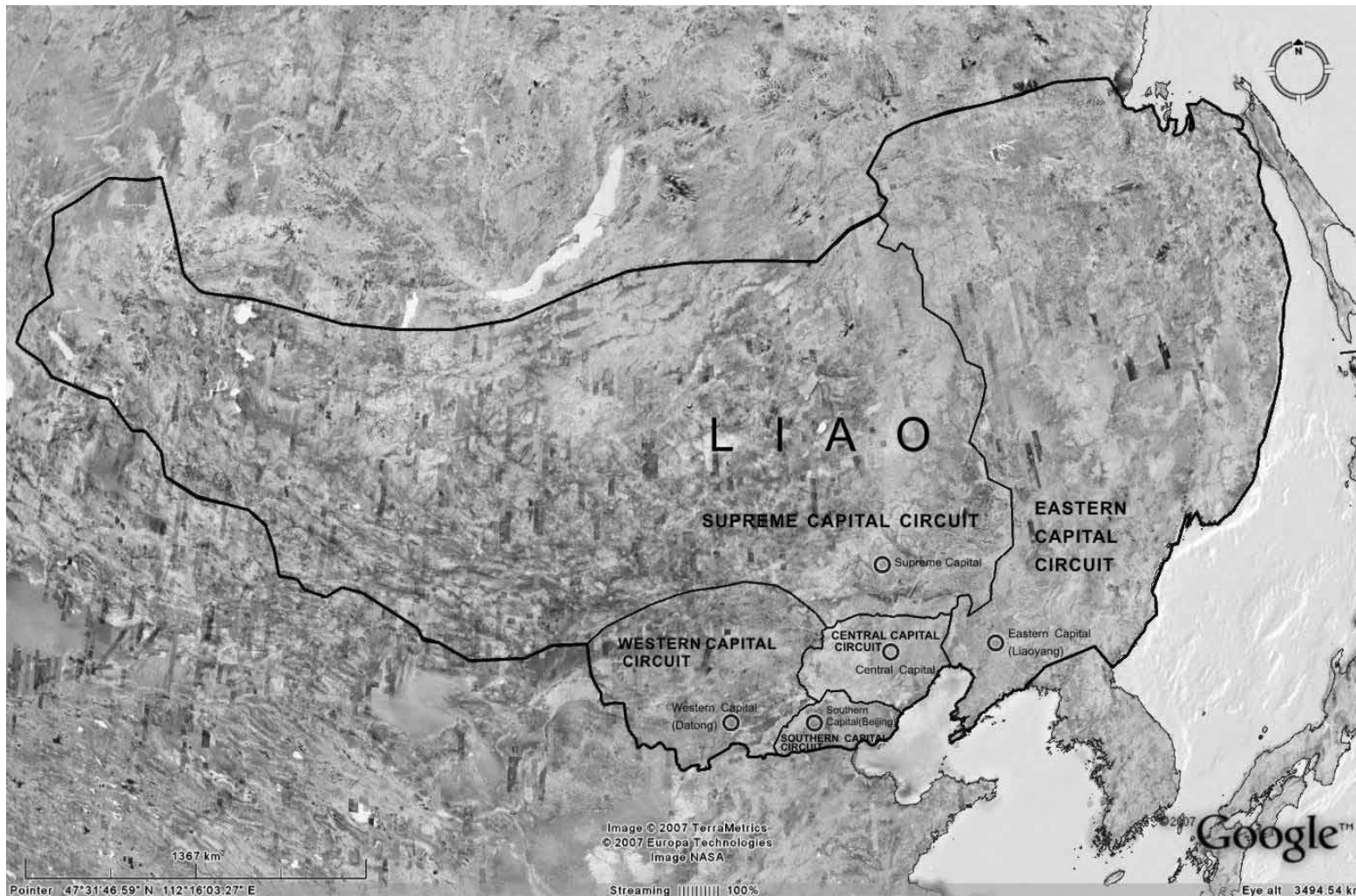

Map 2: The administrative division of Liao (google map, after Tan Qixiang, 1982)

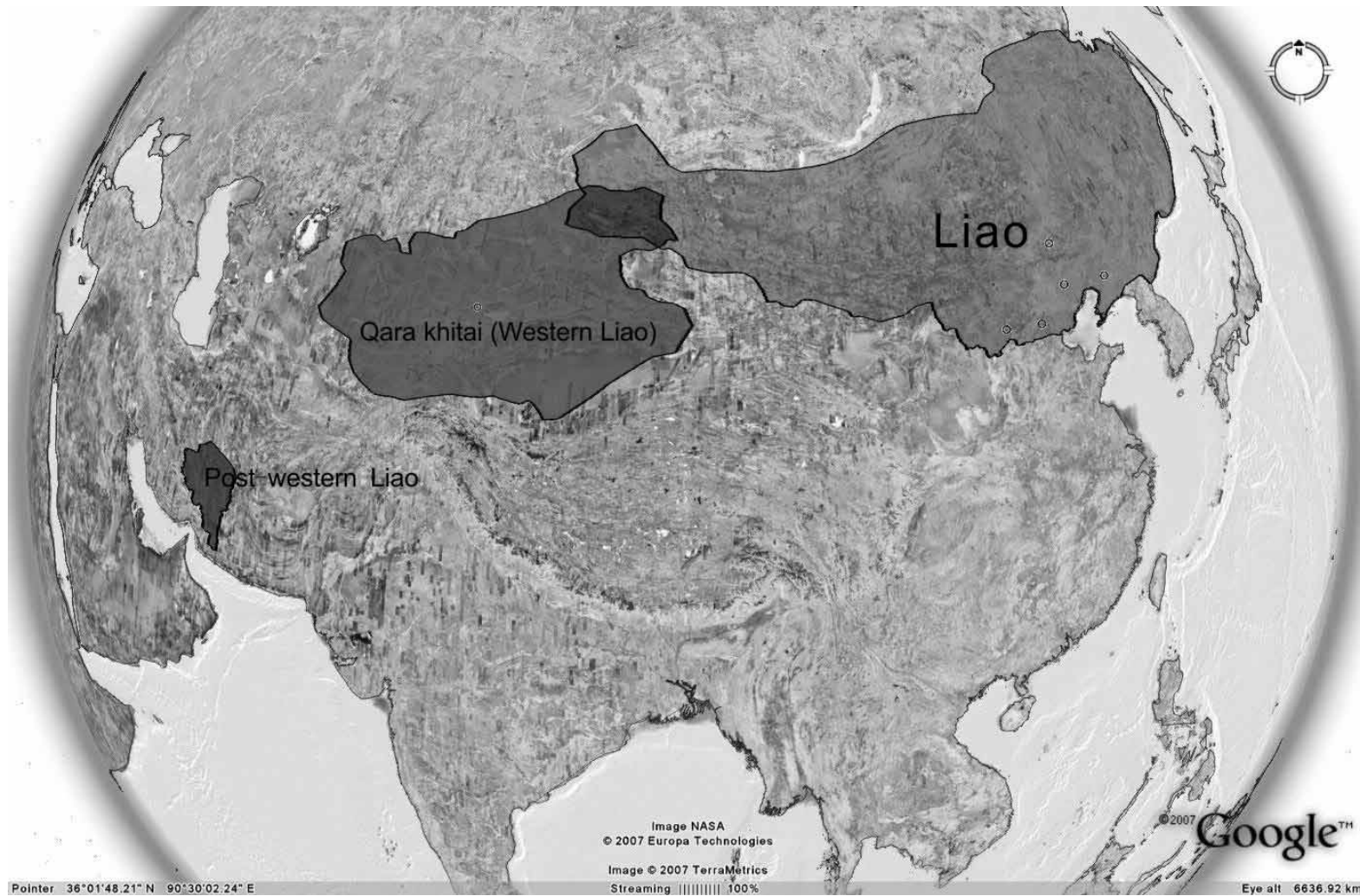

Map 3: The reference location of Liao (Khitan), Western Liao (Qara Khitai) and Post-Western Liao (Kirman)

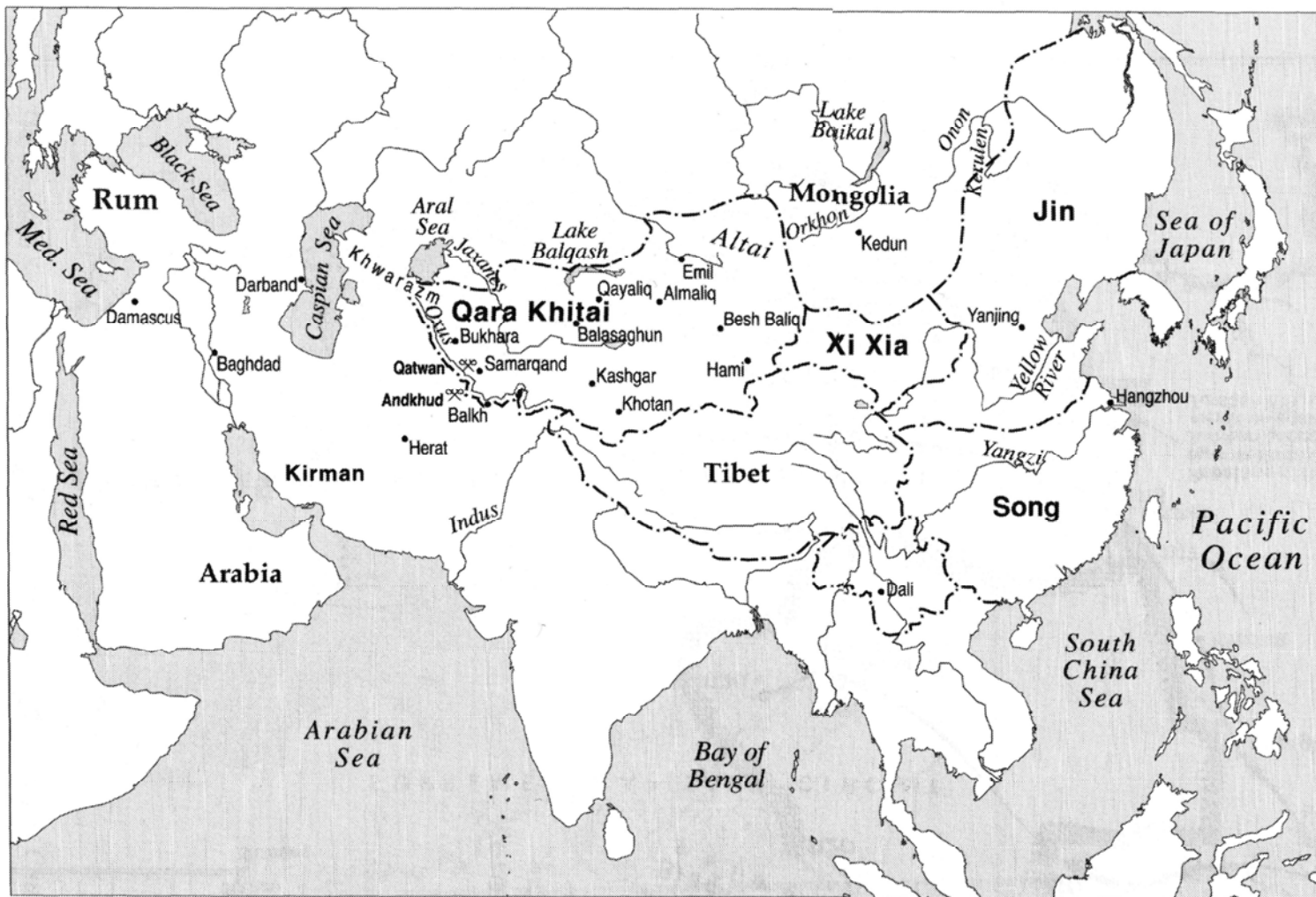

Map 4: Asia ca. 1142 AD : the Qara khitai (Western Liao) empire (after Biran 2005, 220, map3)

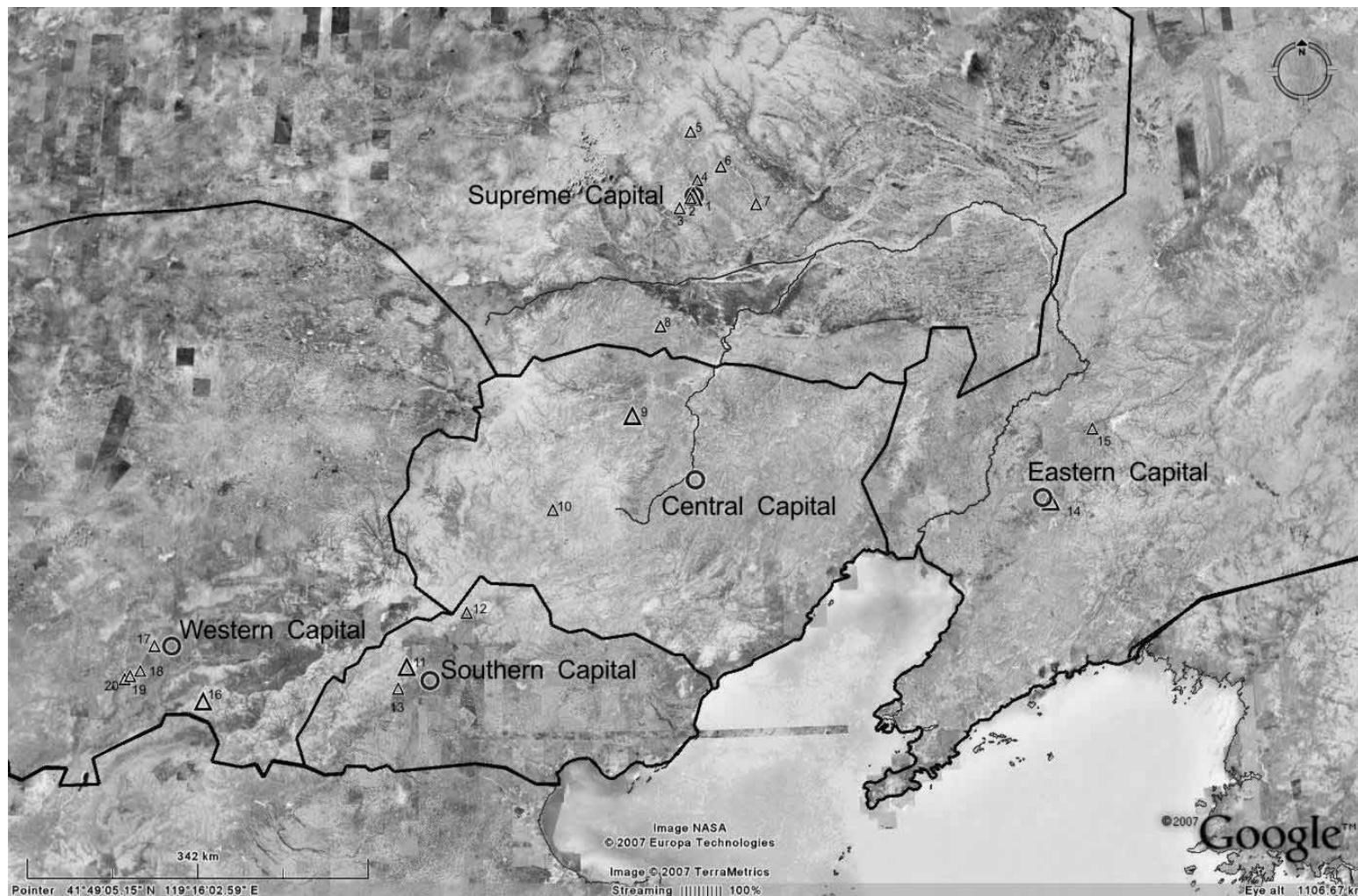

Map 5: Liao kiln sites

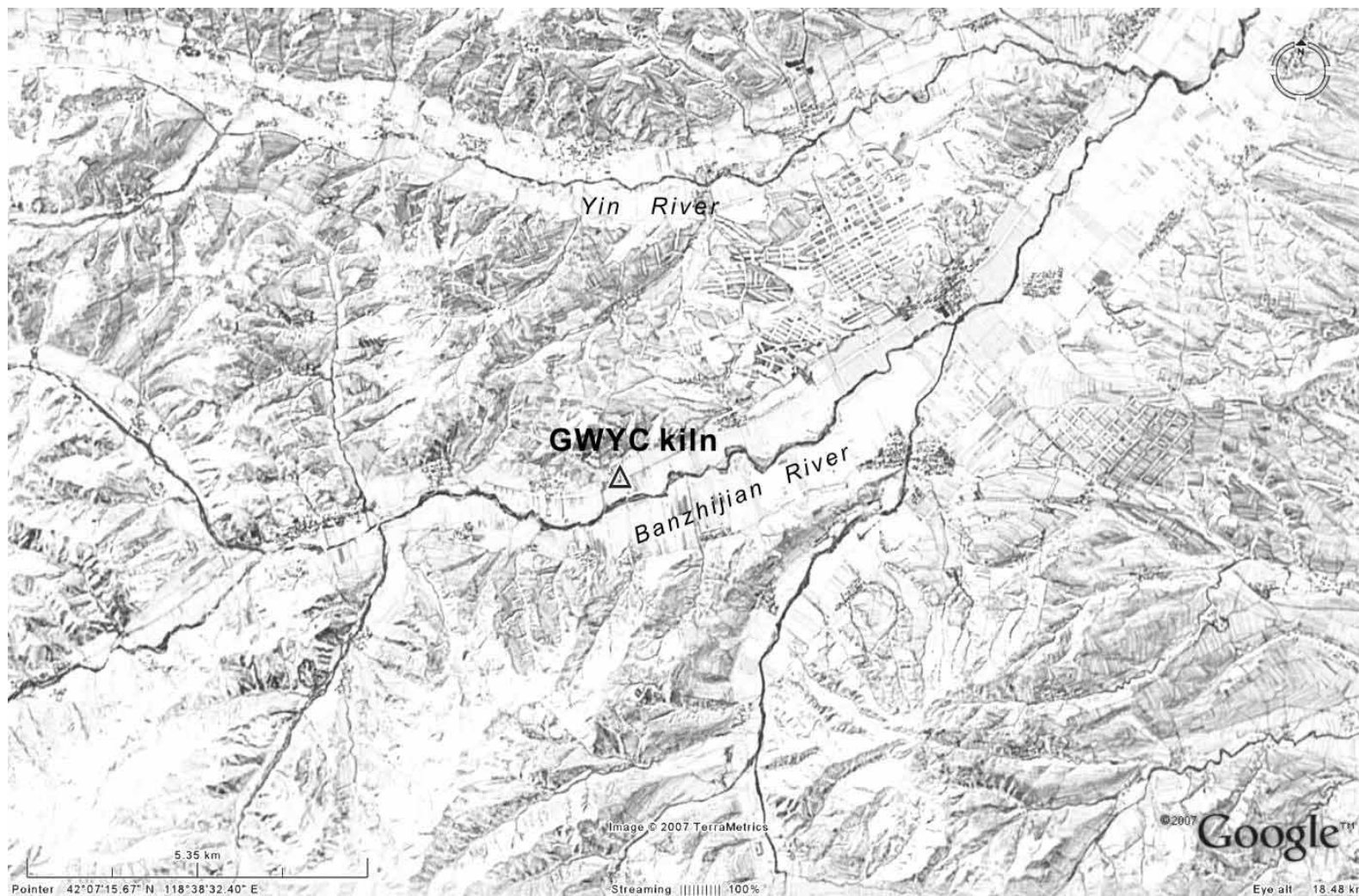

Map 6: GWYC kiln site

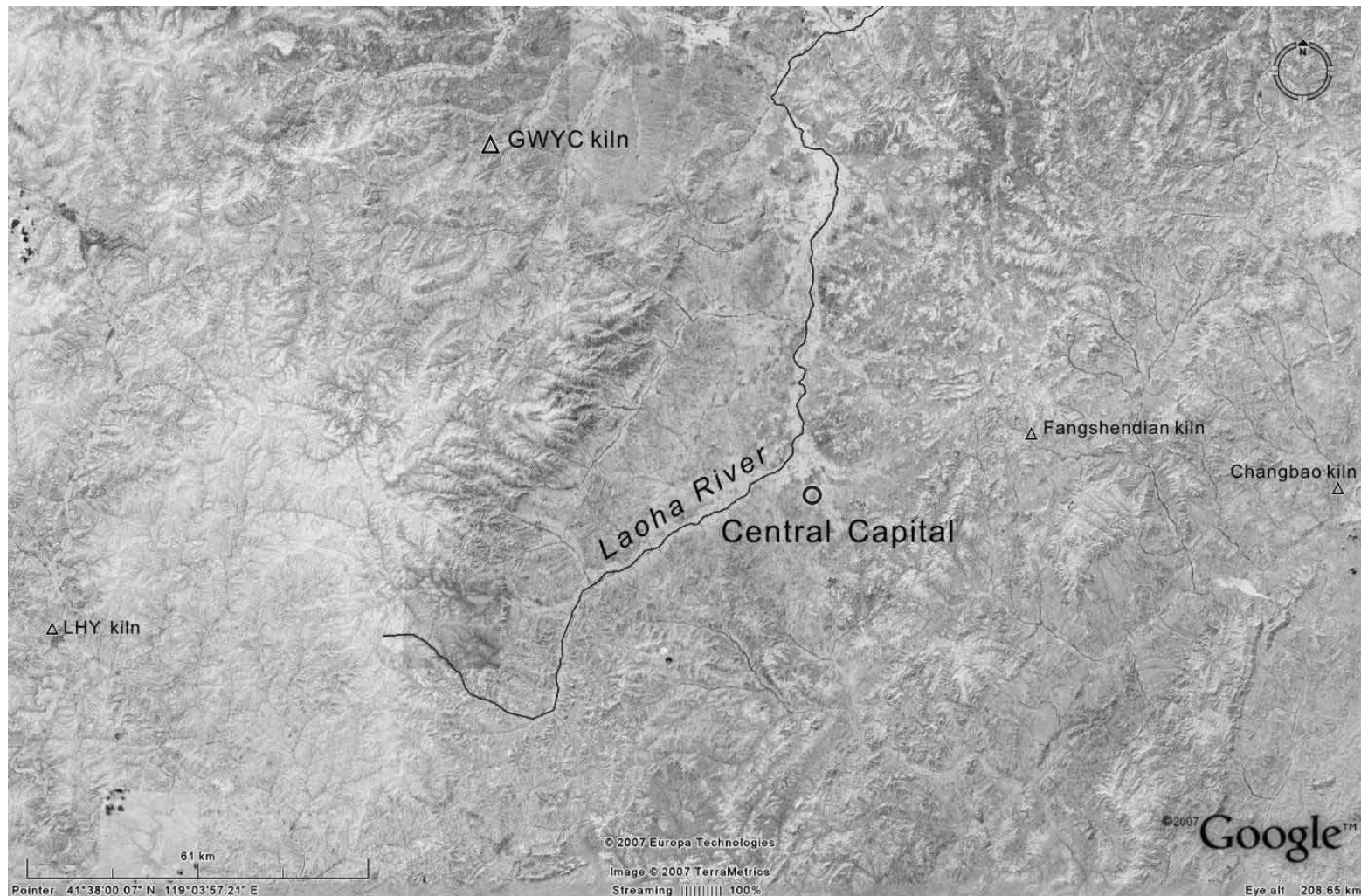

Map 7 ; Liao kiln sites around the Central Capital



Map 8: SJY kiln site



Map 9: Liao kiln sites around the Supreme Capital

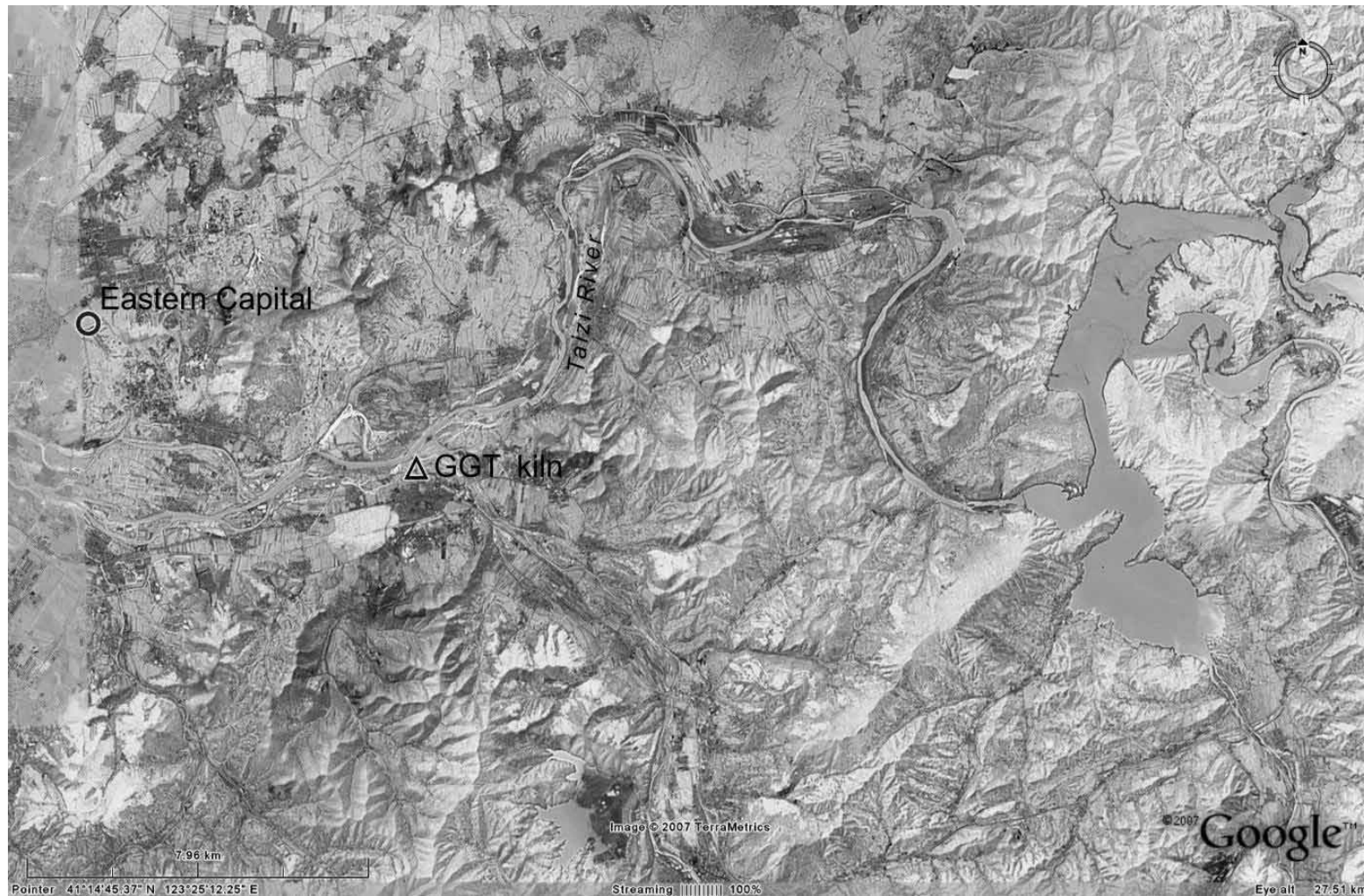

Map 10: GGT kiln site

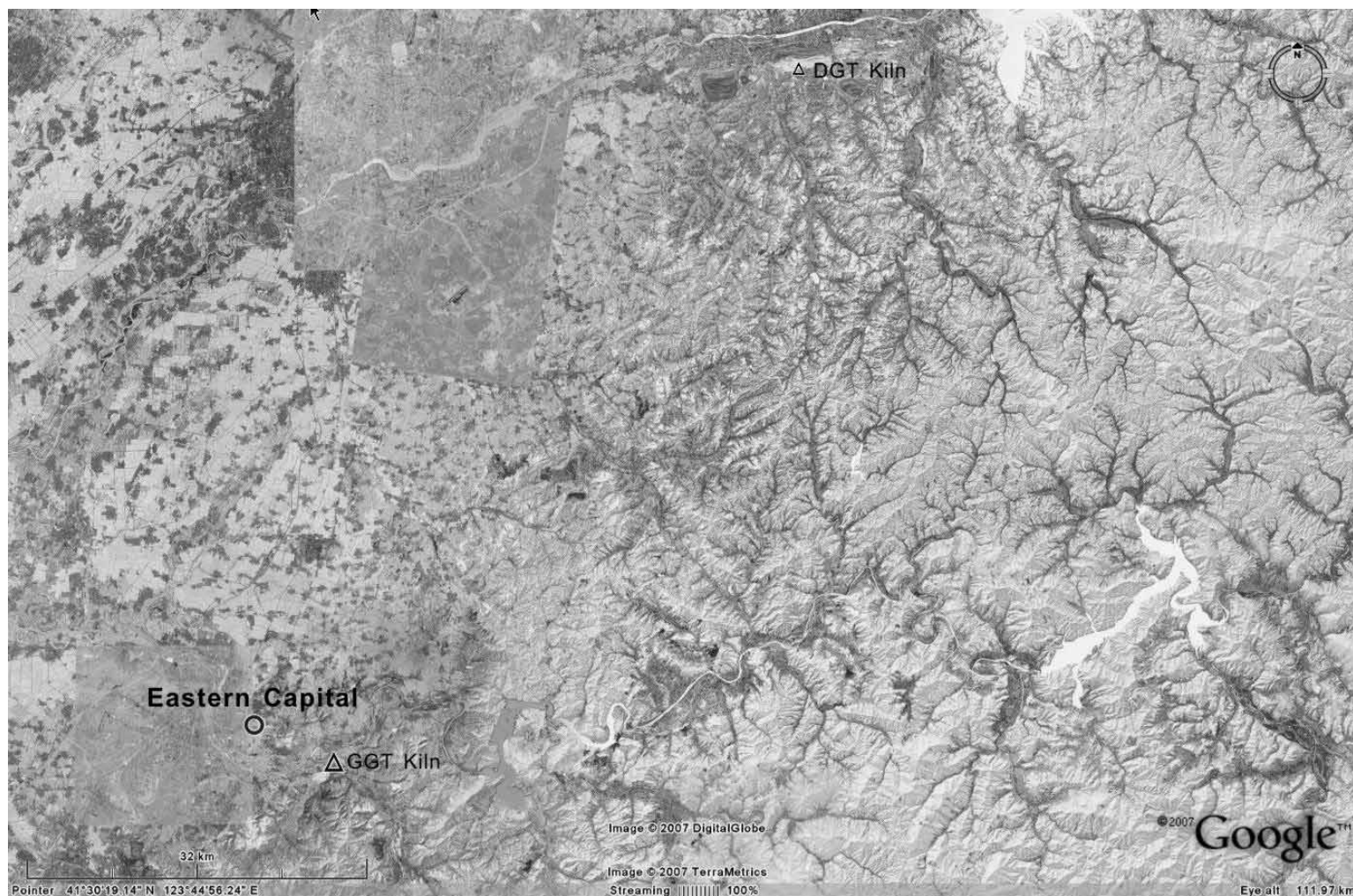

Map 11: Liao kiln sites around the Eastern Capital

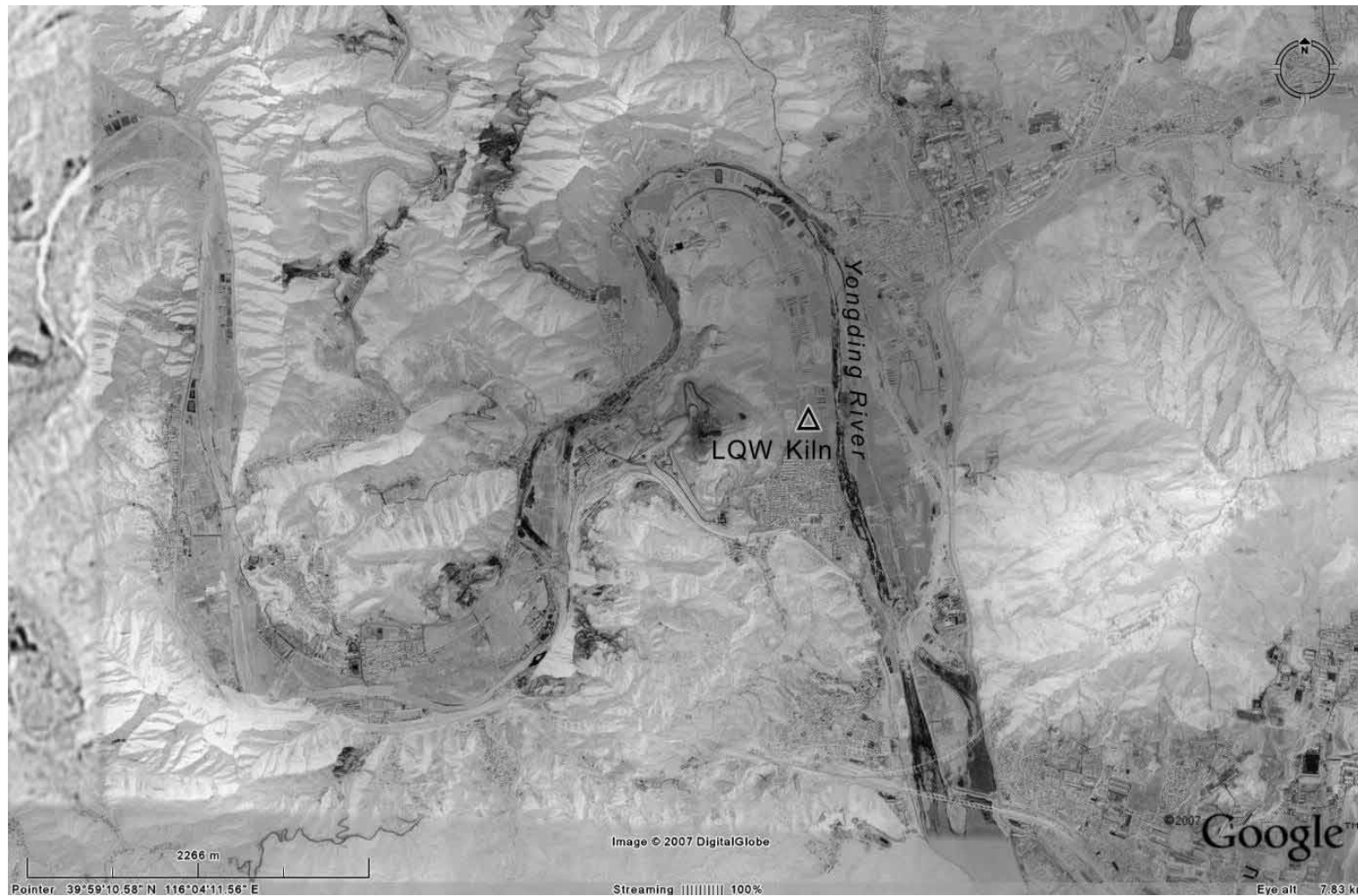

Map 12: LQW kiln site



Map 13: Liao kiln sites around the Southern Capital



Map 14: JZY kiln site



Map 15: Liao kiln sites around the Western Capital

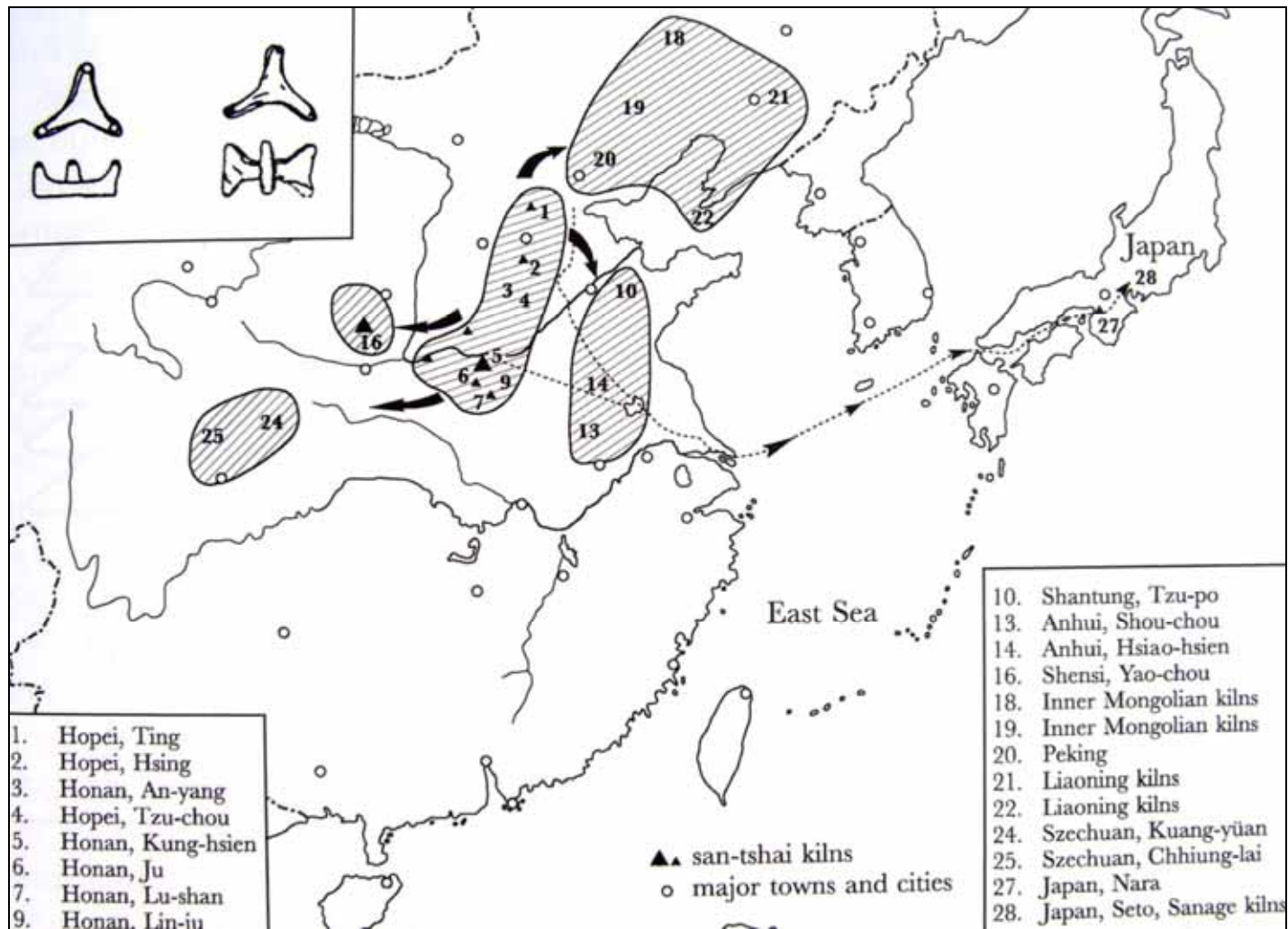

Map 16: Spread and distribution of the triangular kiln-setting support in China (after Kerr & Wood 2004, 341, fig. 86)

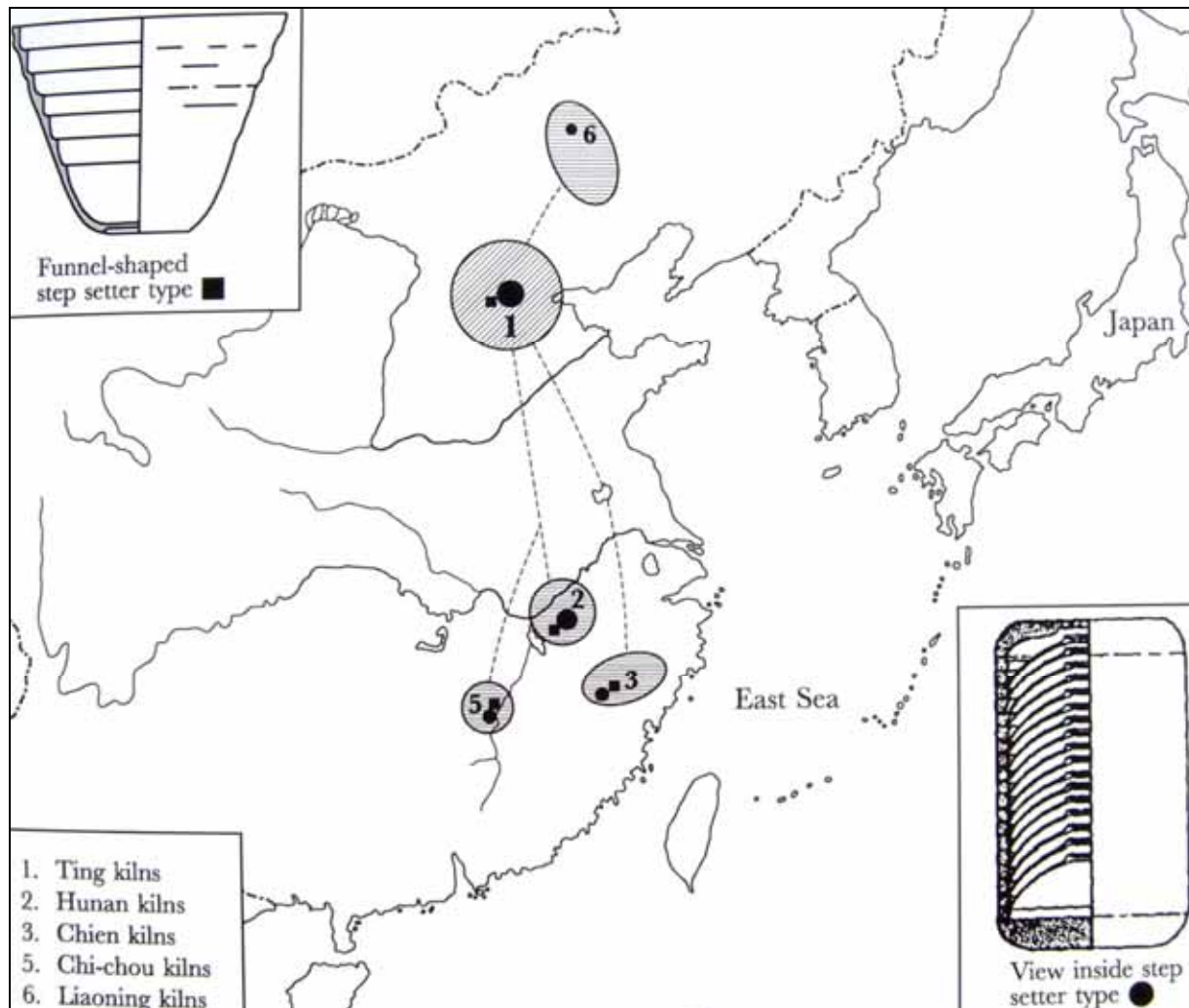



Map 17: Spread of the step-setter technique (after Kerr & Wood 2004, 345, fig. 89)





CATALOGUE

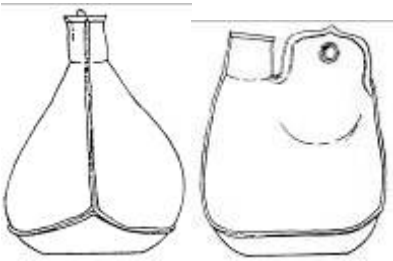

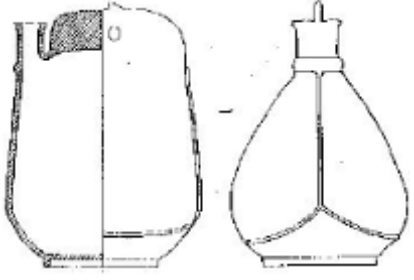
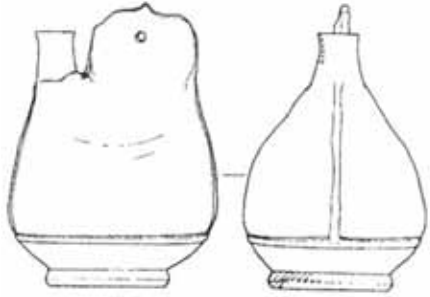
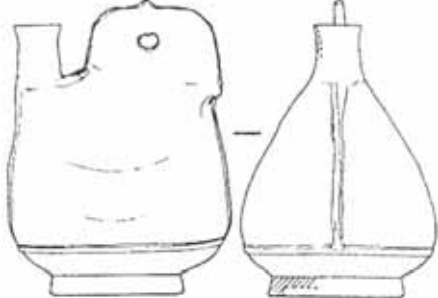
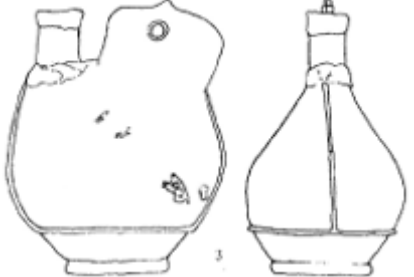

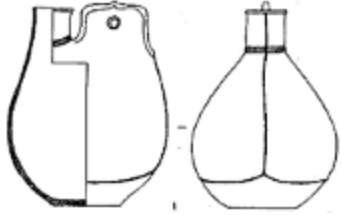
3.1 BAG-SHAPED PILGRIM FLASK



3.1.1 GROUP 1



<p>Catalogue No. : Cat. 1 Group : Gr.1 Type : Aa Body : Porcelain Glaze : White Decoration : Raised ridges; vertical straps Size (cm) : Height:29 ;Diameter of mouth:4-4.7. Unearthed From : Qijiazhi tomb at Fuxin, Liaoning Collected By : Culture bureau of Fuxin, Liaoning province Date (AD) : early Published by : Zhao Zhensheng & Bai Jie 1995, 1008-12, fig.3:3; Zhongguo taoci quanji bianji weiyuanhui 1999, Pl.21</p>	 <p>Cat. 1</p>
<p>Catalogue No. : Cat. 2 Group : Gr.1 Type : Aa Body : Porcelain Glaze : White Decoration : Raised ridges Size (cm) : Height:23.5 ;Diameter of base: 4.1. Unearthed From : FMM(Dayingzi M1) at chifeng, Inner Mongolia Collected By : Inner Mongolia autonomous region museum Date (AD) : 959 Published by : Zheng Shaozong 1956, 1-26, fig.6:2; zhonghua shiji tan & Neimenggu bowuguan 2004, Pl.221; Zhongguo taoci quanji bianji weiyuanhui 1999, Pl.41.</p>	 <p>Cat. 2</p>
<p>Catalogue No. : Cat. 3 Group : Gr.1 Type : Aa Body : Pinkish-buff earthenware Glaze : White Decoration : Raised ridges Size (cm) : Height: 26.7 Unearthed From : HLB1 Collected By : Date (AD) : early Published by : Li Yufeng 1991,106-119, fig.6:2.</p>	 <p>Cat. 3</p>



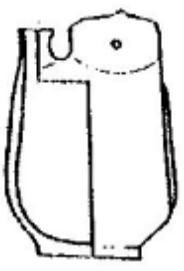

<p>Catalogue No. : Cat. 4 Group : Gr.1 Type : Aa Body : Pinkish-buff earthenware Glaze : Green Decoration : Raised ridges Size (cm) : Height:25 Unearthed From : DQTL3 Collected By : Date (AD) : early Published by : Meng Jianren & Piao Chunyue 1997,651-67, fig.8:1.</p>	 <p>Cat. 4</p>
<p>Catalogue No. : Cat. 5 Group : Gr.1 Type : Aa Body : Pinkish-buff earthenware Glaze : Green Decoration : Raised ridges Size (cm) : Height:23.5;Diameter of mouth:3.5; Diameter of base: 10 Unearthed From : Chaoyanggou M2:20, at Zhangwu, Liaoning Collected By : Zhangwushi wenwu guanlisuo Date (AD) : early Published by : Li Yufeng et al. 2003, 83-111, fig.26:3.</p>	 <p>Cat. 5</p>
<p>Catalogue No. : Cat. 6 Group : Gr.1 Type : Aa Body : Pinkish-buff earthenware Glaze : Green Decoration : Raised ridges Size (cm) : Height:24;Diameter of mouth:3.8; Diameter of base: 11.2 Unearthed From : Chaoyanggou M2:19, at Zhangwu, Liaoning Collected By : Zhangwushi wenwu guanlisuo Date (AD) : early Published by : Li Yufeng et al. 2003, 83-111, fig.26:2.</p>	 <p>Cat. 6</p>
<p>Catalogue No. : 7 Group : Gr.1 Type : Aa Body : Pinkish-buff earthenware Glaze : Green Decoration : Raised ridges Size (cm) : Height:24;Diameter of mouth:3.8; Diameter of base: 11.2 Unearthed From : Zhangjiatun M1 at Kangping, Liaoning Collected By : Tielingshi museum Date (AD) : early Published by : Pei Yaojun 1996, 57-72, fig.3:3.</p>	 <p>Cat. 7</p>

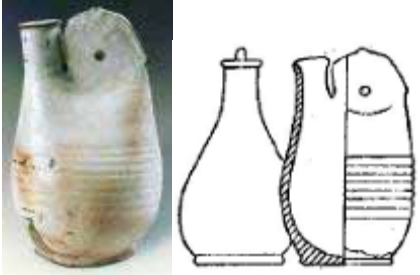
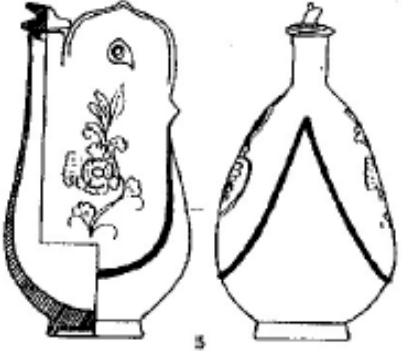

<p>Catalogue No. : Cat. 8 Group : Gr.1 Type : Aa Body : Pinkish-buff earthenware Glaze : Tee-dust Green Decoration : Raised ridges Size (cm) : Height:29.5;Diameter of mouth:5.85; Diameter of base: 9.9. Unearthed From : Wusuyigen tomb at Ganggensumu, Balin Left banner,Inner Mongolia Collected By : Balin Left banner museum Date (AD) : early Published by : Siri Guleng 2002, 110-13, fig.1:1; Neimenggu zizhiqiu wenhuating & Zhongguo lishi bowuguan, 2002, Pl.260.</p>	 <p>Cat. 8</p> 
<p>Catalogue No. : Cat. 9 Group : Gr.1 Type : Aa Body : porcelain Glaze : white Decoration : Raised ridges Size (cm) : Height:26.5;Diameter of mouth:4.9; Diameter of belly: 21-19.3. Diameter of base: 11.1. Unearthed From : Collected By : Liaoning provincial museum Date (AD) : early Published by : Liaoningsheng bowuguan 1961, pl. 15.</p>	 <p>Cat. 9</p>
<p>Catalogue No. : Cat. 10 Group : Gr.1 Type : Aa Body : Pinkish-buff earthenware Glaze : Tee-dust Green Decoration : Raised ridges Size (cm) : Height:27.7;Diameter of mouth:3.8; Diameter of base: 10.2. Unearthed From : a tomb at Yebaishou station, Jianping county, Liaoning Collected By : Liaoning provincial museum Date (AD) : early Published by : Xu Bingkun & Sun Shoudao ed.1998,Pl.235; Liaoningsheng bowuguan 1961,Pl.16.</p>	 <p>Cat. 10</p>

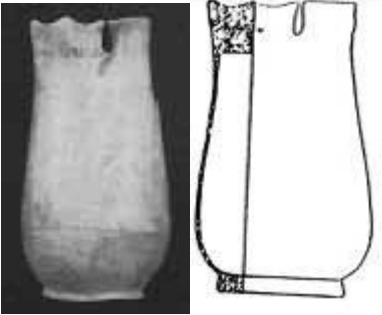

<p>Catalogue No. : Cat. 11 Group : Gr.1 Type : Aa Body : Porcelain Glaze : White Decoration : Raised ridges Size (cm) : Height:25.4;Diameter of mouth:3.9; Diameter of base: 11.2. Unearthed From : Collected By : Beijing gugong bowuyuan Date (AD) : early Published by : Zhongguo taoci quanji bianji weiyuanhui 1999, Pl.25.</p>	 <p>Cat. 11</p>
<p>Catalogue No. : Cat. 12 Group : Gr.1 Type : Aa Body : Pinkish-buff earthenware Glaze : Green Decoration : Raised ridges Size (cm) : Height:27.7. Unearthed From : Collected By : Tokyo national museum Date (AD) : Published by : Sugimura Yuzo 1974, Pl.1.</p>	 <p>Cat. 12</p>
<p>Catalogue No. : Cat. 13 Group : Gr.1 Type : Aa Body : Pinkish-buff earthenware Glaze : Green Decoration : Raised ridges Size (cm) : Height: 24.8. Unearthed From : Collected By : Royal Ontario museum, Toronto Date (AD) : Published by : Sugimura Yuzo 1974, Pl.25. Mino Yutaka et al. 1971,p.246: Pl.1. Mino Yutaka et al. 1973,Pl.3.</p>	 <p>Cat. 13</p>
<p>Catalogue No. : Cat. 14 Group : Gr.1 Type : Aa Body : Pinkish-buff earthenware Glaze : Green Decoration : Raised ridges Size (cm) : Height: 26.5. Unearthed From : Collected By : Center of Asian Art and Culture,Avery Brundage Collection ,San Francisco, California Date (AD) : Published by : Mino Yutaka et al. 1973,Pl.2; Los Angeles County Museum, The Arts of the T'ang Dynasty, 1957, P1. 275; d'Argence, "Early' Chinese Ceramics," Apollo, vol. LXXXIV, no. 54 (1966), p. 99: Fig. 36; d'Argence, op. cit., Pl. LVIII: C.</p>	 <p>Cat. 14</p>

<p>Catalogue No. : Cat. 15 Group : Gr.1 Type : Aa Body : Pinkish earthenware Glaze : Tee-dust Green Decoration : Raised ridges Size (cm) : Height:25;Diameter of mouth:4.6; Diameter of base: 9. Unearthed From : Xiaowangyedi tomb at Xindi township, Aohan Banner, Inner Mogolia Collected By : Aohan banner museum Date (AD) : Published by : Shao Guotian ed. 2004,p.137:2.</p>	 <p>Cat. 15</p>
<p>Catalogue No. : Cat. 16 Group : Gr.1 Type : Aa Body : Pinkish earthenware Glaze : Tee-dust Green Decoration : Raised ridges Size (cm) : Height:25;Diameter of mouth:4.6; Diameter of base: 9. Unearthed From : Huaganzigou tomb at Hao'er tu township, Balin Left banner, Inner Mongolia Collected By : Liao shangjing museum Date (AD) : Published by : Tang Cailan 2005,Pl.50.</p>	 <p>Cat. 16</p>
<p>Catalogue No. : Cat. 17 Group : Gr.1 Type : Aa Body : Pinkish earthenware Glaze : white Decoration : Size (cm) : Height: 27. Unearthed From : XTTG3 Collected By : Date (AD) : middle Published by : Qi Xiaoguang 1991, 68-71.</p>	 <p>Cat. 17</p>
<p>Catalogue No. : Cat. 18 Group : Gr.1 Type : Aa Body : Pinkish earthenware Glaze : white Decoration : Raised ridge Size (cm) : Height: 35; Diameter of base: 11.4. Unearthed From : a tomb at Sanqidi village, Huajialaga township, Balin Left banner Collected By : Liaoshangjing museum, Inner Mongolia Date (AD) : Published by : Tang Cailan 2005, pl. 51-1.</p>	 <p>Cat. 18</p>

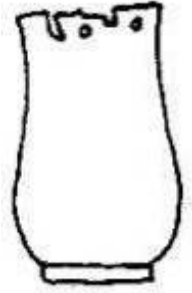
<p>Catalogue No. : Cat. 19 Group : Gr.1 Type : Aa Body : Pinkish earthenware Glaze : green Decoration : Size (cm) : Height: 22 Unearthed From : Collected By : Private collection, Japan Date (AD) : Published by : Sugimura Yuzo 1974, Pl.26.</p>	 <p>Cat. 19</p>
<p>Catalogue No. : Cat. 20 Group : Gr.1 Type : Aa Body : Pinkish earthenware Glaze : white Decoration : Size (cm) : Height:29;Diameter of mouth:5.1; Diameter of base:12. Unearthed From : QHM4 Collected By : Liaoning provincial museum Date (AD) : middle Published by : Zhongguo taoci quanji bianji weiyuanhui,1999, Pl.11; Li Wenxin 1954, 163-202, fig.22:2; Liaoningsheng bowuguan 1961, pl. 14.</p>	 <p>Cat. 20</p>
<p>Catalogue No. : Cat. 21 Group : Gr.1 Type : Aa Body : Pinkish earthenware Glaze : white Decoration : Incised peony design Size (cm) : Height:27.6;Diameter of mouth:3.2; Diameter of base:8.4. Unearthed From : Hebutehada tomb at Bayanerdeng sumu, Balin Right Banner, Inner Mongolia Collected By : Balin Right Banner Museum , Inner Mongolia Date (AD) : middle Published by : Siri Guleng 2000, 110-13, fig.1:3.</p>	 <p>Cat. 21</p>
<p>Catalogue No. : Cat. 22 Group : Gr.1 Type : Aa Body : Pinkish earthenware Glaze : green Decoration : Size (cm) : Height: 23. Unearthed From : Collected By : Tokyo national museum Date (AD) : Published by : Sugimura Yuzo 1974, Pl.28.</p>	 <p>Cat. 22</p>

<p>Catalogue No. : Cat. 23 Group : Gr.1 Type : Aa Body : Pinkish earthenware Glaze : green Decoration : Size (cm) : Height: 24. Unearthed From : SJG1 Collected By : Date (AD) : 1002 Published by : Deng Baoxue et al. 1983, 30-38, fig.2:1.</p>	 <p>Cat. 23</p>
<p>Catalogue No. : Cat. 24 Group : Gr.1 Type : Aa Body : Pinkish earthenware Glaze : green Decoration : Size (cm) : Height: 23.5. Unearthed From : Collected By : Guan Baocong collection Date (AD) : Published by : Lu Jing 2003, pl. 3-74.</p>	 <p>Cat. 24</p>
<p>Catalogue No. : Cat. 25 Group : Gr.1 Type : Aa Body : Pinkish earthenware Glaze : green Decoration : Size (cm) : Height:24.5;Diameter of mouth:3; Diameter of base:9.5. Unearthed From : Collected By : Guan Baocong collection Date (AD) : Published by : Lu Jing 2003, pl.4-164.</p>	 <p>Cat. 25</p>
<p>Catalogue No. : Cat. 26 Group : Gr.1 Type : Aa Body : Pinkish earthenware Glaze : green Decoration : Size (cm) : Height: 23. Unearthed From : Collected By : Guan Baocong collection Date (AD) : Published by : Lu Jing 2003, pl.3-75</p>	 <p>Cat. 26</p>

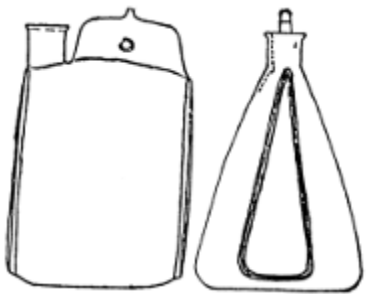
<p>Catalogue No. : Cat. 27 Group : Gr.1 Type : Aa Body : Pinkish earthenware Glaze : green Decoration : Incised peony design Size (cm) : Height: 24. Unearthed From : a tomb at Pingfangzi ,Kazuo county , Liaoning Collected By : Kazuo museum, Liaoning Date (AD) : Published by : Shanghai renmin meishu chubanshe 1986, pl.143.</p>	 <p>Cat. 27</p>
<p>Catalogue No. : Cat. 28 Group : Gr.1 Type : Aa Body : Pinkish earthenware Glaze : green Decoration : Size (cm) : Height: 24. Unearthed From : SJG1 Collected By : Date (AD) : 1002 Published by : Deng Baoxue et al. 1983, 30-38.</p>	 <p>Cat. 28</p>
<p>Catalogue No. : Cat. 29 Group : Gr.1 Type : Aa Body : Pinkish earthenware Glaze : green Decoration : White painted peony design Size (cm) : Height:26.9; Diameter of belly: 14.2-9.5;Diameter of base:11.9-7.9. Unearthed From : Collected By : Liaoning provincial museum Date (AD) : Published by : Zhongguo taoci quanji bianji weiyuanhui,1999, Pl. 86.</p>	 <p>Cat. 29</p>
<p>Catalogue No. : Cat. 30 Group : Gr.1 Type : Aa Body : Pinkish earthenware Glaze : green Decoration : White painted peony design Size (cm) : Height:26.9. Unearthed From : Collected By : Date (AD) : Published by : Mok 1985, pl. 14.</p>	 <p>Cat. 30</p>

<p>Catalogue No. : Cat. 31 Group : Gr.1 Type : Aa Body : Pinkish earthenware Glaze : white Decoration : Size (cm) : Height:19;Diameter of mouth:3.3-3.9; Diameter of belly: 12.1-11.4;Diameter of base:7.3. Unearthed From : Collected By : Liaoning provincial museum Date (AD) : Published by : Zhongguo taoci quanji bianji weiyuanhui,1999, Pl.37; Shanghai renmin meishu chubanshe 1986, pl.20; Liaoningsheng bowuguan 1961, pl.13.</p>	 <p>Cat. 31</p>
<p>Catalogue No. : Cat. 32 Group : Gr.1 Type : Ab Body : Pinkish earthenware Glaze : green Decoration : Size (cm) : Height: 25. Unearthed From : SZG1 Collected By : Date (AD) : early Published by : Shao Guotian 1987, 889-904.</p>	 <p>Cat. 32</p>
<p>Catalogue No. : Cat. 33 Group : Gr.1 Type : Ab Body : porcelain Glaze : white Decoration : Size (cm) : Height:26.2;Diameter of mouth:5; Diameter of belly: 16;Diameter of base:16.5. Unearthed From : FMM Collected By : Neimenggu zizhiqu bowuguan, Inner Mongolia Date (AD) : 959 Published by : Zheng Shaozong, 1956, 1-26, fig.6:1; Zhongguo taoci quanji bianji weiyuanhui,1999, Pl.42; Mok, 1985, Pl.8.</p>	 <p>Cat. 33</p>
<p>Catalogue No. : Cat. 34 Group : Gr.1 Type : Ab Body : porcelain Glaze : white Decoration : Size (cm) : Height: 27. Unearthed From : Collected By : Capital museum, Beijing Date (AD) : early Published by :</p>	 <p>Cat. 34</p>

Catalogue No. : Cat. 35
 Group : Gr.1
 Type : Ab
 Body : Pinkish earthenware
 Glaze : white
 Decoration :
 Size (cm) : Height: 27.
 Unearthed From : BZLG
 Collected By :
 Date (AD) : middle
 Published by : Su Ritai, 1982, 64-68, fig.5:4.

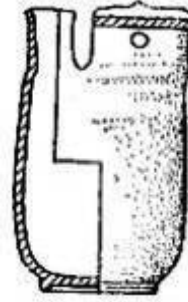

Cat. 35

Catalogue No. : Cat. 36
 Group : Gr.1
 Type : Ab
 Body : Pinkish earthenware
 Glaze : Dark green
 Decoration :
 Size (cm) : Height: 25; Diameter of mouth: 3;
 Diameter of base: 11.5.
 Unearthed From : XHD
 Collected By :
 Date (AD) : middle
 Published by : Wang Gang 1998, 44-49, fig.3:4.

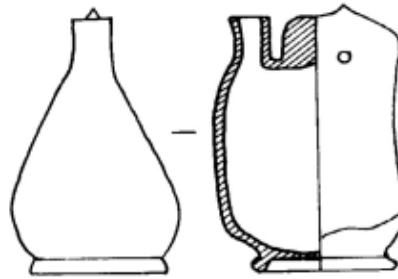

Cat. 36

Catalogue No. : Cat. 37
 Group : Gr.1
 Type : Ab
 Body : Pinkish earthenware
 Glaze : green
 Decoration :
 Size (cm) : Height: 27; diameter of mouth:4.
 Unearthed From :
 Collected By : Jinlin provincial museum
 Date (AD) :
 Published by : Shanghai renmin meishu chubanshe
 1986, pl.131.











Cat. 37





Catalogue No. : Cat. 38
 Group : Gr.1
 Type : Ab
 Body : Pinkish earthenware
 Glaze : green
 Decoration :
 Size (cm) : Height: 25; diameter of mouth:15.
 Unearthed From : a tomb at Shazigou in
 Jinchanggouliang township, Aohan Banner, Inner
 Mongolia
 Collected By : Aohan Banner Museum, Inner
 Mongolia
 Date (AD) :
 Published by : Shao Guotian ed. 2004,138.





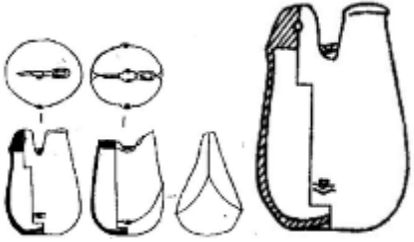



Cat. 38





<p>Catalogue No. : Cat. 39 Group : Gr.1 Type : Ab Body : Pinkish earthenware Glaze : green Decoration : Size (cm) : Height: 24.5. Unearthed From : DEQG Collected By : Date (AD) : middle I Published by : Cong Yanshuang 1992, 149-151.</p>	 <p>Cat. 39</p>
<p>Catalogue No. : Cat. 40 Group : Gr.1 Type : Ab Body : Pinkish earthenware Glaze : green Decoration : Size (cm) : Height: 24.7. Unearthed From : Collected By : Tokyo national museum Date (AD) : Published by : Sugimura Yuzo 1974, Pl.27.</p>	 <p>Cat. 40</p>
<p>Catalogue No. : Cat. 41 Group : Gr.1 Type : Ab Body : Pinkish earthenware Glaze : green Decoration : Size (cm) : Height: 26.8. Unearthed From : Collected By : Philadelphia museum of art Date (AD) : Published by : Mino Yutaka et al. 1973, pl.5.</p>	 <p>Cat. 41</p>
<p>Catalogue No. : Cat. 42 Group : Gr.1 Type : Ab Body : Pinkish earthenware Glaze : green Decoration : Size (cm) : Height: 25.2. Unearthed From : Collected By : Indianapolis museum of art gift of Charles L. Freer Date (AD) : Published by : Mino Yutaka et al. 1973, pl.6.</p>	 <p>Cat. 42</p>





<p>Catalogue No. : Cat. 43 Group : Gr.1 Type : Ab Body : Pinkish earthenware Glaze : green Decoration : Size (cm) : Height: 27.5. Unearthed From : Collected By : Philadelphia museum of art Date (AD) : Published by : Mino Yutaka et al. 1973, pl.4.</p>	 <p>Cat. 43</p>
<p>Catalogue No. : Cat. 44 Group : Gr.1 Type : Ab Body : Pinkish earthenware Glaze : green Decoration : Size (cm) : Height: 23.5; Diameter of mouth: 4.5; Diameter of base: 9.3., Unearthed From : a tomb at Lindong Zhuanchang, Balin Left Banner, Inner Mongolia Collected By : Liao shangjing museum, Inner Mongolia Date (AD) : Published by : Tang Cailan 2005, pl.51.</p>	 <p>Cat. 44</p>
<p>Catalogue No. : Cat. 45 Group : Gr.1 Type : Ab Body : Pinkish earthenware Glaze : green Decoration : Size (cm) : Height: 27; Diameter of mouth: 3.5; Diameter of base: 11., Unearthed From : Collected By : Guan Baocong collection Date (AD) : Published by : Lu Jing 2003, Pl. 4-158.</p>	 <p>Cat. 45</p>
<p>Catalogue No. : Cat. 46 Group : Gr.1 Type : Ab Body : Pinkish earthenware Glaze : green Decoration : Size (cm) : Height: 17.5; Diameter of mouth: 3. Unearthed From : Collected By : Guan Baocong collection Date (AD) : Published by : Shanghai renmin meishu chubanshe 1986, pl. 96.</p>	 <p>Cat. 46</p>





<p>Catalogue No. : Cat. 47 Group : Gr.1 Type : B Body : grey polishing pottery Glaze : Decoration : Size (cm) : Height: 26. Unearthed From : a tomb at Yuliangbao, tongliao, Inner Mongolia Collected By : Date (AD) : early Published by : Xi Mude 1988, 41-42, fig.2:1,2.</p>	 <p>Cat. 47</p>
<p>Catalogue No. : Cat. 48 Group : Gr.1 Type : B Body : Black polishing pottery Glaze : Decoration : Size (cm) : Height: 26. Unearthed From : Tomb at Shangshaoguo, louzidian township, kalaqin banner, Inner Mongolia Collected By : Chifeng municipal museum, Inner Mongolia Date (AD) : early Published by : Neimenggu zizhiqiu wenhuating & Zhongguo lishi bowuguan 2002, pl.258; Shanghai renmin meishu chubanshe 1986, pl.2.</p>	 <p>Cat. 48</p>
<p>Catalogue No. : Cat. 49 Group : Gr.1 Type : B Body : grey polishing pottery Glaze : Decoration : Size (cm) : Height: 26.8; Diameter of mouth: 4.9. Unearthed From : Tomb at Shangshaoguo, louzidian township, kalaqin banner, Inner Mongolia Collected By : Chifeng municipal museum, Inner Mongolia Date (AD) : early Published by : Shanghai renmin meishu chubanshe 1986, pl.3.</p>	 <p>Cat. 49</p>
<p>Catalogue No. : Cat. 50 Group : Gr.1 Type : B Body : Porcelain Glaze : white Decoration : Size (cm) : Height: 36.1; Diameter of belly: 28.5-26.3. Unearthed From : Collected By : Liaoning provincial museum Date (AD) : early Published by : Zhongguo taoci quanji bianji weiyuanhui, 1999, Pl. 29.</p>	 <p>Cat. 50</p>

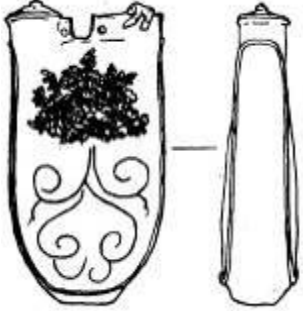



<p>Catalogue No. : Cat. 51 Group : Gr.1 Type : B Body : Pinkish earthenware Glaze : green Decoration : Size (cm) : Height: 22.8; Diameter of belly: 21.6-20.3; Diameter of base: 17.4. Unearthed From : Collected By : Liaoning provincial museum Date (AD) : early Published by : Zhongguo taoci quanji bianji weiyuanhui, 1999, Pl. 82; shanghai renmin meishu chubanshe 1986, pl.1; Liaoningsheng bowuguan 1961, pl.17..</p>	 <p>Cat. 51</p>
<p>Catalogue No. : Cat. 52 Group : Gr.1 Type : B Body : Pinkish earthenware Glaze : green Decoration : Incised design Size (cm) : Height: 23; Diameter of mouth: 4.4. Unearthed From : GDG Collected By : Chifeng municipal museum, Inner Mongolia Date (AD) : Middle Published by : Xiang Chunsong 1989, 41-44, fig.7; Zhongguo taoci quanji bianji weiyuanhui, 1999, Pl. 81; Neimenggu zizhiqu wenhuating & Zhongguo lishi bowuguan 2002, pl.265; Mok 1985, pl.12; Shanghai remin meishu chubanshe 1986, pl.13.</p>	 <p>Cat. 52</p>
<p>Catalogue No. : Cat. 53 Group : Gr.1 Type : B Body : Pinkish earthenware Glaze : brown Decoration : Size (cm) : Height: 25.4; Diameter of mouth:5. Unearthed From : YMT7 Collected By : Liaoning provincial museum Date (AD) : Middle Published by : Liaoningsheng bowuguan et al. 1975, 26-36; Zhongguo taoci quanji bianji weiyuanhui, 1999, Pl.56; Shanghai remin meishu chubanshe 1986, pl.23.</p>	 <p>Cat. 53</p>
<p>Catalogue No. : Cat. 54 Group : Gr.1 Type : B Body : Pinkish earthenware Glaze : brown Decoration : Size (cm) : Height: 25.5; Diameter of mouth:5. Unearthed From : YMT7 Collected By : Liaoning provincial museum Date (AD) : Middle Published by : Feng Yongqian 1975, 40-48, fig5:4; Xu Bingkun & Sun Shoudao ed. 1998, pl.236.</p>	 <p>Cat. 54</p>





<p>Catalogue No. : Cat. 55 Group : Gr.1 Type : B Body : Pinkish earthenware Glaze : yellow Decoration : Incised design Size (cm) : Height: 24; Diameter of mouth: 5.7. Unearthed From : a tomb at Tong County, Beijing Collected By : Capital museum, Beijing Date (AD) : middle I Published by : Zhongguo taoci quanji bianji weiyuanhui,1999, Pl. 64; Shoudu bowuguan 1991, pl. 37.</p>	 <p>Cat. 55</p>
<p>Catalogue No. : Cat. 56 Group : Gr.1 Type : B Body : Pinkish earthenware Glaze : yellow Decoration : Incised design Size (cm) : Height: 25.5. Unearthed From : AXZ Collected By : Date (AD) : middle I Published by : Beijingshi wenwu yanjiusuo 1992, 17-23, fig.4:7,8.</p>	 <p>Cat. 56</p>
<p>Catalogue No. : Cat. 57 Group : Gr.1 Type : B Body : Pinkish earthenware Glaze : green Decoration : Incised and applied design Size (cm) : Height: 31; Diameter of mouth: 5.5. Unearthed From : SQ1 Collected By : Liaoning provincial museum Date (AD) : middle Published by : Xu Yulin 1977, 44-51, fig.21:1; Shanghai renmin meishu chubanshe 1986, pl. 64.</p>	 <p>Cat. 57</p>
<p>Catalogue No. : Cat. 58 Group : Gr.1 Type : B Body : Pinkish earthenware Glaze : green Decoration : Incised and applied design Size (cm) : Height: 27; Diameter of belly: 9.2-15.6. Unearthed From : SQ1 Collected By : Liaoning provincial museum Date (AD) : middle Published by : Xu Yulin 1977, 44-51, fig.21:2; Zhongguo taoci quanji bianji weiyuanhui 1999, pl.84..</p>	 <p>Cat. 58</p>





<p>Catalogue No. : Cat. 59 Group : Gr.1 Type : B Body : Pinkish earthenware Glaze : green Decoration : Incised and applied design Size (cm) : Height: 26.5; Diameter of belly: 17.6-8.1. Unearthed From : QCH Collected By : Liaoning provincial museum Date (AD) : 1004 Published by : Zhongguo taoci quanji bianji weiyuanhui 1999, pl.80; Xu Bingkun & Sun Shoudao ed. 1998, pl. 238. Jin Fengyi 1980, 17-29, fig.7.</p>	 <p>Cat. 59</p>
<p>Catalogue No. : Cat. 60 Group : Gr.1 Type : B Body : Pinkish earthenware Glaze : green Decoration : Incised and applied design Size (cm) : Height: 29; Diameter of mouth: 5.8. Unearthed From : QCH Collected By : Liaoning provincial museum Date (AD) : 1004 Published by : Jin Fengyi 1980, 17-29, fig.7. Shanghai renmin meishu chubanshe 1986, pl. 75. Watson 1984, pl.269.</p>	 <p>Cat. 60</p>
<p>Catalogue No. : Cat. 61 Group : Gr.1 Type : B Body : Pinkish earthenware Glaze : green Decoration : Incised and applied design Size (cm) : Height: 27. Unearthed From : a tomb at Guangdegong township, Wengniute Banner, Inner Mongolia Collected By : Wengniute Banner Museum, Inner Mongolia Date (AD) : middle Published by : Neimenggu zizhiqu wenhuating & Zhongguo lishi bowuguan 2002, pl.267; Shanghai bowuguan 2000, pl.181; Shen Hsueh-man 2006, pl.40.</p>	 <p>Cat. 61</p>
<p>Catalogue No. : Cat. 62 Group : Gr.1 Type : B Body : Pinkish earthenware Glaze : green Decoration : Incised design Size (cm) : Height: 29; Diameter of belly: 17.3-10.2; Diameter of mouth: 5.8; Diameter of base: 7.5-8.3. Unearthed From : ELC Collected By : Liaoning provincial museum Date (AD) : middle Published by : Zhongguo taoci quanji bianji weiyuanhui 1999, pl.81; Zhang Baizhong 1985, 56-62, fig.4:1; Liaoningsheng bowuguan 1961, pl.18.</p>	 <p>Cat. 62</p>



<p>Catalogue No. : Cat. 63 Group : Gr.1 Type : B Body : Pinkish earthenware Glaze : green Decoration : Incised and applied design Size (cm) : Height: 24.5; Diameter of base: 5. Unearthed From : ELC Collected By : Inner Mongolia Autonomous Region Museum Date (AD) : middle Published by : zhonghua shiji tan & Neimenggu bowuguan 2004, pl.220; Zhang Baizhong 1985, 56-62.</p>	 <p>Cat. 63</p>
<p>Catalogue No. : Cat. 64 Group : Gr.1 Type : B Body : Pinkish earthenware Glaze : green Decoration : Incised design Size (cm) : Height: 18; Diameter of mouth: 4.5. Unearthed From : Collected By : Liaoning provincial museum Date (AD) : middle Published by : Shanghai renmin meishu chubanshe 1986, pl.83.</p>	 <p>Cat. 64</p>
<p>Catalogue No. : Cat. 65 Group : Gr.1 Type : B Body : Pinkish earthenware Glaze : green Decoration : Incised and applied design Size (cm) : Height: 35.4; Diameter of mouth: 5.8; Width: 18.5. Unearthed From : YWG Collected By : Luanping museum, Hebei Date (AD) : middle Published by : Ma Qingpeng & Zhao Zhihou 1997, 47-49, fig.1:1.</p>	 <p>Cat. 65</p>
<p>Catalogue No. : Cat. 66 Group : Gr.1 Type : B Body : Pinkish earthenware Glaze : green Decoration : Incised and applied design Size (cm) : Height: 35.4; Diameter of mouth: 5.8; Width: 18.5. Unearthed From : YWG Collected By : Luanping museum, Hebei Date (AD) : middle Published by : Ma Qingpeng & Zhao Zhihou 1997, 47-49, fig.1:2.</p>	 <p>Cat. 66</p>





<p>Catalogue No. : Cat. 67 Group : Gr.1 Type : B Body : Pinkish earthenware Glaze : green Decoration : incomplete Size (cm) : Unearthed From : WDM Collected By : Luanping museum, Hebei Date (AD) : middle Published by : Zhang Hanying 1996, 18-25, fig1:6.</p>	 <p>Cat. 67</p>
<p>Catalogue No. : Cat. 68 Group : Gr.1 Type : B Body : Pinkish earthenware Glaze : green Decoration : Incised scrolling vines Size (cm) : Height: 30. Unearthed From : HXM Collected By : Hebei provincial museum Date (AD) : 1017 Published by : Tang Yunming 1973, 276-78, pl.4:4; Tong Zhuchen 1989, pl.3:2.</p>	 <p>Cat. 68</p>
<p>Catalogue No. : Cat. 69 Group : Gr.1 Type : B Body : Pinkish earthenware Glaze : green Decoration : Incised scrolling vines and applied relief design Size (cm) : Height: 34.3. Unearthed From : GYY Collected By : Chaoyang museum, Liaoning Date (AD) : 1020 Published by : Zhu Zifang & Xu Ji 1983,168-95,fig.20:6.</p>	 <p>Cat. 69</p>
<p>Catalogue No. : Cat. 70 Group : Gr.1 Type : B Body : Pinkish earthenware Glaze : green Decoration : Incised scrolling vines and applied relief design Size (cm) : Height: 34.4. Unearthed From : GYY Collected By : Chaoyang museum, Liaoning Date (AD) : 1020 Published by : Zhu Zifang & Xu Ji 1983,168-95,fig.20:1.</p>	 <p>Cat. 70</p>



<p>Catalogue No. : Cat. 71 Group : Gr.1 Type : B Body : Pinkish earthenware Glaze : yellow Decoration : Incised scrolling vines Size (cm) : Height: 22.3; Diameter of mouth 4.4; Diameter of belly: 15.6-11.3; Diameter of base: 7.3. Unearthed From : a tomb at Zhangjiayingzi, Jianping, Liaoning Collected By : Liaoning provincial museum Date (AD) : middle Published by : Liaoningsheng bowuguan 1961, pl.20.</p>	 <p>Cat. 71</p>
<p>Catalogue No. : Cat. 72 Group : Gr.1 Type : B Body : Pinkish earthenware Glaze : yellow Decoration : Incised scrolling vines Size (cm) : Height: 24. Unearthed From : a tomb at Fuxingmenwai, Beijing Collected By : Date (AD) : middle Published by : Lu Jing 2003, pl. 4-322.</p>	 <p>Cat. 72</p>
<p>Catalogue No. : Cat. 73 Group : Gr.1 Type : B Body : Pinkish earthenware Glaze : green Decoration : Incised scrolling vines and sculptured monkey Size (cm) : Height: 31.7. Unearthed From : Collected By : Museum of Fine Arts, Boston Date (AD) : middle Published by : Mok 1985, Pl.19.</p>	 <p>Cat. 73</p>
<p>Catalogue No. : Cat. 74 Group : Gr.1 Type : B Body : Pinkish earthenware Glaze : green Decoration : Incised scrolling vines and sculptured monkey Size (cm) : Height: 31.9. Unearthed From : Collected By : Museum of Fine Arts: Hoyt Coll., Boston(50.1747-8) Date (AD) : middle Published by : Watson 1984, pl. 266.</p>	 <p>Cat. 74</p>

<p>Catalogue No. : Cat. 75 Group : Gr.1 Type : B Body : Pinkish earthenware Glaze : green Decoration : Incised scrolling vines Size (cm) : Height: 31.2; Diameter of mouth: 6.2; Diameter of belly: 16.3-12.1; Diameter of base:7. Unearthed From : Collected By : Liaoning provincial museum Date (AD) : middle Published by : Liaoningsheng bowuguan 1961, pl. 19.</p>	 <p>Cat. 75</p>
<p>Catalogue No. : Cat. 76 Group : Gr.1 Type : B Body : Pinkish earthenware Glaze : green Decoration : Incised scrolling vines Size (cm) : Height: 27. Unearthed From : Collected By : Philadelphia Museum of Art Date (AD) : middle Published by : Mino Yutaka et al. 1973, pl. 7.</p>	 <p>Cat. 76</p>
<p>Catalogue No. : Cat. 77 Group : Gr.1 Type : B Body : Pinkish earthenware Glaze : green Decoration : Incised scrolling vines Size (cm) : Height: 22.3. Unearthed From : Collected By : Center of Asian Art and Culture, Avery Brundage Collection San Francisco, California Date (AD) : middle Published by : Mino Yutaka et al. 1973, pl. 7.</p>	 <p>Cat. 77</p>
<p>Catalogue No. : Cat. 78 Group : Gr.1 Type : B Body : Pinkish earthenware Glaze : green Decoration : Incised scrolling vines Size (cm) : Height: 22. Unearthed From : Collected By : Mr. Victor Hauge ,Falls Church, Virginia Date (AD) : middle Published by : Mino Yutaka et al. 1973, pl. 9.</p>	 <p>Cat. 78</p>

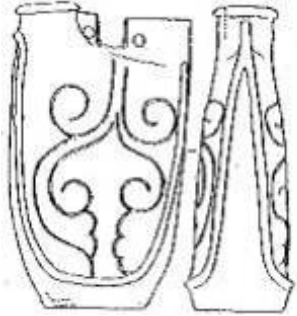
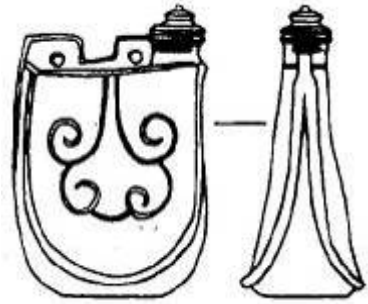
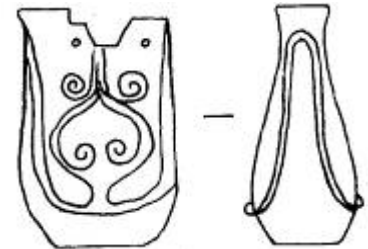

<p>Catalogue No. : Cat. 79 Group : Gr.1 Type : B Body : Pinkish earthenware Glaze : green Decoration : Incised scrolling vines Size (cm) : Height: 25. Unearthed From : Collected By : Tokyo university Date (AD) : middle Published by : Sugimura Yuzo 1974, pl.29.</p>	 <p>Cat. 79</p>
<p>Catalogue No. : Cat. 80 Group : Gr.1 Type : B Body : Pinkish earthenware Glaze : green Decoration : Incised scrolling vines Size (cm) : Height: 27.3. Unearthed From : Collected By : Private collection, Japan Date (AD) : middle Published by : Sugimura Yuzo 1974, pl.30.</p>	 <p>Cat. 80</p>
<p>Catalogue No. : Cat. 81 Group : Gr.1 Type : B Body : Pinkish earthenware Glaze : green Decoration : Incised scrolling vines Size (cm) : Height: 31.2; Diameter of belly: 16.3-12.1; Diameter of base:9. Unearthed From : Collected By : Liaoning provincial Museum Date (AD) : middle Published by : Zhongguo taoci quanji bianji weiyuanhui 1999, pl.76.</p>	 <p>Cat. 81</p>
<p>Catalogue No. : Cat. 82 Group : Gr.1 Type : B Body : porcelain Glaze : white Decoration : Incised scrolling vines Size (cm) : Height: 23.3; Diameter of mouth: 5; Diameter of belly: 16-10.1; Diameter of base: 7.7. Unearthed From : Collected By : Liaoning provincial Museum Date (AD) : middle Published by : Zhongguo taoci quanji bianji weiyuanhui 1999, pl. 20; .Shanghai renmin meishu chubanshe 1986, pl.142; Liaoningsheng bowuguan 1961, pl.21.</p>	  <p>Cat. 82</p>

<p>Catalogue No. : Cat. 83 Group : Gr.1 Type : B Body : Pinkish earthenware Glaze : green Decoration : Incised scrolling vines Size (cm) : Height: 21. Unearthed From : a tomb at Haiwang village, Xuanwu district, Beijing Collected By : Date (AD) : middle Published by : Beijingshi wenwu guanlichu 1972, 35-40, fig.3.</p>	 <p>Cat. 83</p>
<p>Catalogue No. : Cat. 84 Group : Gr.1 Type : B Body : Pinkish earthenware Glaze : green Decoration : Incised scrolling vines Size (cm) : Height: 25.6; Width: 14.2; Diameter of base: 7.5-7.8. Unearthed From : a tomb Yingfenggou, Xindi Township, Aohan Banner, Inner Mongolia Collected By : Aohan Banner Museum Date (AD) : middle Published by : Shao Guotian ed. 2004, pl.119.</p>	 <p>Cat. 84</p>
<p>Catalogue No. : Cat. 85 Group : Gr.1 Type : B Body : Pinkish earthenware Glaze : green Decoration : Incised scrolling vines and sculptured monkey Size (cm) : Height: 30.7; Diameter of mouth: 6. Unearthed From : Collected By : Liaoning Provincial museum Date (AD) : middle Published by : Zhongguo taoci quanji bianji weiyuanhui 1999, pl.92.</p>	 <p>Cat. 85</p>
<p>Catalogue No. : Cat. 86 Group : Gr.1 Type : B Body : Pinkish earthenware Glaze : green Decoration : Applied relief design(dragon and chrysanthemum) Size (cm) : Height: 29.5; Diameter of mouth: 5.9; Diameter of belly: 18.8-12.2; Diameter of base: 9.8-8.9. Unearthed From : Collected By : Liaoning Provincial museum Date (AD) : middle Published by : Zhongguo taoci quanji bianji weiyuanhui 1999, pl.89; Shanghai renmin meishu chubanshe 1986, pl.36; Liaoningsheng bowuguan 1961, pl.1; Xu Bingkun & Sun Shoudao ed. 1998, pl.237.</p>	 <p>Cat. 86</p>

<p>Catalogue No. : Cat. 87 Group : Gr.1 Type : B Body : Pinkish earthenware Glaze : white Decoration : Sculptured monkey Size (cm) : Height: 24; Diameter of mouth: 4.7. Unearthed From : Collected By : Chifengshi wenwu gongzuozhan, Inner Mongolia Date (AD) : middle Published by : Zhongguo taoci quanji bianji weiyuanhui 1999, pl.7; Shanghai renmin meishu chubanshe 1986, pl.116.</p>	 <p>Cat. 87</p>
<p>Catalogue No. : Cat. 88 Group : Gr.1 Type : B Body : Pinkish earthenware Glaze : green Decoration : Incised scrolling vines Size (cm) : Height: 29.6. Unearthed From : GZX Collected By : Chaoyang museum, Liaoning Date (AD) : 1026 Published by : Zhu Zifang & Xu Ji 1983,168-95,fig.4:1; Mok 1985, fig 16e.</p>	 <p>Cat. 88</p>
<p>Catalogue No. : Cat. 89 Group : Gr.1 Type : B Body : Pinkish earthenware Glaze : green Decoration : Incised scrolling vines Size (cm) : Height: 29.6. Unearthed From : GZX Collected By : Chaoyang museum, Liaoning Date (AD) : 1026 Published by : Zhu Zifang & Xu Ji 1983,168-95,fig.4:5; Mok 1985, fig 16f.</p>	 <p>Cat. 89</p>
<p>Catalogue No. : Cat. 90 Group : Gr.1 Type : B Body : Pinkish earthenware Glaze : green Decoration : Incised scrolling vines Size (cm) : Height: 29.5. Unearthed From : BL1 Collected By : Liaoning provincial museum Date (AD) : middle Published by : Wu Jiachang 1986, 32-51, fig4:5.</p>	 <p>Cat. 90</p>

<p>Catalogue No. : Cat. 91 Group : Gr.1 Type : B Body : Pinkish earthenware Glaze : green Decoration : Incised scrolling vines Size (cm) : Height: 26. Unearthed From : PJG1 Collected By : Aohan Banner Museum, Inner Mongolia Date (AD) : middle Published by : Ji Ping 1997, 639-50, fig.6.</p>	 <p>Cat. 91</p>
<p>Catalogue No. : Cat. 92 Group : Gr.1 Type : B Body : Pinkish earthenware Glaze : green Decoration : Incised scrolling vines Size (cm) : Height: 21; Diameter of mouth: 3.6; Diameter of belly: 13.3-8.5.. Unearthed From : YMT22 Collected By : Aohan Banner Museum, Inner Mongolia Date (AD) : middle Published by : Xu Zhiguo & Wei Chunguang 2000, 48-51, fig.3:1.</p>	 <p>Cat. 92</p>
<p>Group : Cat. 93 Type : B Body : Pinkish earthenware Glaze : green Decoration : Incised scrolling vines Size (cm) : Height: 28; Diameter of mouth: 6.4; Diameter of belly 18.4; Diameter of base: 10.4. Unearthed From : DPC Collected By : Zhangwuxian wenwu guanlisuo Date (AD) : middle Published by : Liu Junyu & Sun Gang 1999, 31-34, fig.3:2.</p>	 <p>Cat. 93</p>
<p>Group : Cat. 94 Type : B Body : Pinkish earthenware Glaze : green Decoration : Incised scrolling vines Size (cm) : Unearthed From : Collected By : Guan Baocong collection Date (AD) : Photo by : Lu Jing</p>	 <p>Cat. 94</p>

3.1.2 GROUP 2

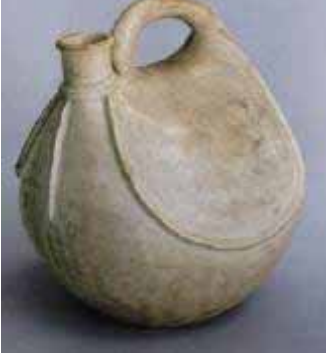
<p>Catalogue No. : Cat. 95 Group : Gr.2 Type : Aa Body : porcelain Glaze : brown Decoration : Raised ridges Size (cm) : Height ; 28.8. Unearthed From : YLYZ Collected By : Research Institute of Cultural Relics and Archaeology of Inner Mongolia Date (AD) : 942 Published by : Qi Xiaoguang et al. 1996, 4-32; Zhongguo taoci quanji bianji weiyuanhui 1999, pl.57; Neimenggu zizhiqiu wenhuating & Zhongguo lishi bowuguan 2002, pl. 257.</p>	 <p>Cat. 95</p>
<p>Catalogue No. : Cat. 96 Group : Gr.2 Type : Aa Body : porcelain Glaze : white Decoration : Raised ridges Size (cm) : Height ; 30.4. Unearthed From : YLYZ Collected By : Research Institute of Cultural Relics and Archaeology of Inner Mongolia Date (AD) : 942 Published by : Qi Xiaoguang et al. 1996, 4-32, fig.48:1; Zhongguo taoci quanji bianji weiyuanhui 1999, pl.43. Neimenggu zizhiqiu wenhuating & Zhongguo lishi bowuguan 2002, pl. 259; Shen Hsueh-man et al. 2006, pl. 39.</p>	 <p>Cat. 96</p>
<p>Catalogue No. : Cat. 97 Group : Gr.2 Type : Aa Body : porcelain Glaze : white Decoration : Raised ridges Size (cm) : Height: 25.5; Diameter of mouth: 3.5. Unearthed From : HLDT1 Collected By : Liaoning Tieling quzhongyishuguan wenwuzu Date (AD) : early Published by : Zhang Shaoqing 1986, 922-5, fig.2; Shanghai renmin meishu chubanshe 1986, pl. 57.</p>	 <p>Cat. 97</p>
<p>Catalogue No. : Cat. 98 Group : Gr.2 Type : Aa Body : porcelain Glaze : white Decoration : Raised ridges Size (cm) : Height: 17; Diameter of mouth: 2.9; Diameter of belly: 15.3-15.3; Diameter of base: 7.4. Unearthed From : Collected By : Liaoning provincial museum Date (AD) : early Published by : Shanghai renmin meishu chubanshe 1986, pl.26; Liaoningsheng bowuguan 1961, pl. 24.</p>	 <p>Cat. 98</p>

Catalogue No. : Cat. 99
 Group : Gr.2
 Type : Aa
 Body : porcelain
 Glaze : white
 Decoration : Raised ridges
 Size (cm) : Height: 18.5; Diameter of mouth: 3.5;
 Diameter of base: 6.5.
 Unearthed From :
 Collected By : Guan Baocong collection
 Date (AD) : early
 Published by : Lu Jing 2003, pl. 4-23.



Cat. 99

Catalogue No. : Cat. 100
 Group : Gr.2
 Type : Aa
 Body : porcelain
 Glaze : white
 Decoration : Raised ridges
 Size (cm) : Height: 24; Diameter of mouth: 5.2;
 Diameter of base: 9.8.
 Unearthed From : a tomb at Baoquan village, Shisan
 aobao township, Balin Left Banner, Inner Mongolia
 Collected By : Liao shangjing museum
 Date (AD) : early
 Published by : Tang Cailan 2005, pl.48.



Cat. 100







Catalogue No. : Cat. 101
 Group : Gr.2
 Type : Aa
 Body : porcelain
 Glaze : white
 Decoration : Raised ridges
 Size (cm) : Height: 30.2; Diameter of mouth: 4.7;
 Diameter of base: 14.
 Unearthed From :
 Collected By : Aohan Banner museum
 Date (AD) : early
 Published by : Shao Guotian ed. 2004, 134.

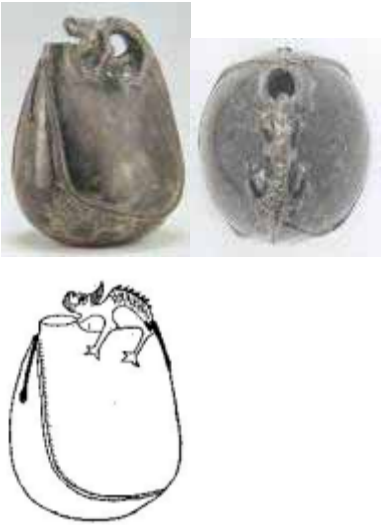
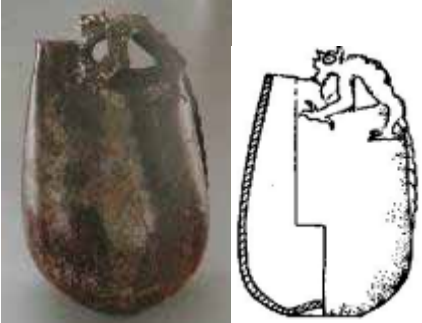
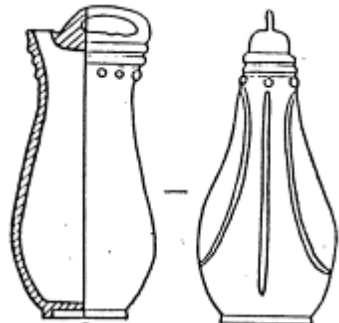

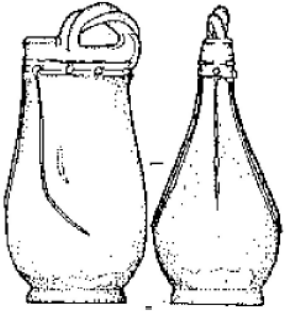
Cat. 101

<p>Catalogue No. : Cat. 102 Group : Gr.2 Type : Aa Body : porcelain Glaze : white Decoration : Raised ridges Size (cm) : Height: 36; Diameter of mouth: 4.5; Diameter of base: 14.4. Unearthed From : Collected By : Guan Baocong collection Date (AD) : early Published by : Lu Jing 2003, pl.4-24.</p>	 <p>Cat. 102</p>
<p>Catalogue No. : Cat. 103 Group : Gr.2 Type : Aa Body : Pinkish earthenware Glaze : green Decoration : Raised ridges; its loop handle is made of a dragon walking on the pot with its head raised and back arched. Size (cm) : Height: 23.4; Diameter of mouth: 3.1; Diameter of base 7.5. Unearthed From : GDG Collected By : Chifeng municipal museum Date (AD) : middle Published by : Xiang Chunsong 1989, 41-44, fig.8; Zhongguo taoci quanji bianji weiyuanhui 1999, pl. 73; Neimenggu zizhiqiu wenhuating & Zhongguo lishi bowuguan 2002, pl. 263; Shanghai bowuguan 2000, pl. 180.</p>	 <p>Cat. 103</p>
<p>Catalogue No. : Cat. 104 Group : Gr.2 Type : Aa Body : Pinkish earthenware Glaze : green Decoration : Dragon-shaped handle Size (cm) : Height: 29.6; Diameter of base 7.5. Unearthed From : BZLG Collected By : Inner Mongolia Autonomous Region museum Date (AD) : middle Published by : Su ritai 1982, 64-48, fig.5: 3; zhonghua shiji tan & Neimenggu bowuguan 2004, pl.218</p>	 <p>Cat. 104</p>
<p>Catalogue No. : Cat. 105 Group : Gr.2 Type : Aa Body : Pinkish earthenware Glaze : green Decoration : Size (cm) : Height: 28. Unearthed From : XSC4 Collected By : Date (AD) : late Published by : Meng Jianren & Qian Yucheng 1994, 542-7, fig.3:3.</p>	 <p>Cat. 105</p>

<p>Catalogue No. : Cat. 106 Group : Gr.2 Type : Aa Body : Pinkish earthenware Glaze : white Decoration : Size (cm) : Height: 31.4. Unearthed From : DSLT1 Collected By : Date (AD) : middle Published by : Wan Xin 1999, 15-23, fig.6:2.</p>	 <p>Cat. 106</p>
<p>Catalogue No. : Cat. 107 Group : Gr.2 Type : Aa Body : Pinkish earthenware Glaze : white Decoration : Size (cm) : Height: 32. Unearthed From : DSLT1 Collected By : Date (AD) : middle Published by : Wan Xin 1999, 15-23, fig.6:3.</p>	 <p>Cat. 107</p>
<p>Catalogue No. : Cat. 108 Group : Gr.2 Type : Aa Body : Pinkish earthenware Glaze : white Decoration : Size (cm) : Height: 33; Diameter of mouth: 2.6; Diameter of base : 9. Unearthed From : a tomb at Dongdashaan, Kelidai township, Aohan Banner, Inner Mongolia Collected By : Date (AD) : middle Published by : Shao Guotian ed. 2004, 139-1.</p>	 <p>Cat. 108</p>
<p>Catalogue No. : Cat. 109 Group : Gr.2 Type : Aa Body : Pinkish earthenware Glaze : white Decoration : Size (cm) : Height: 28.5. Unearthed From : YMT5 Collected By : Date (AD) : middle Published by : Feng Yongqian 1994a, 163-90, fig.9:2.</p>	 <p>Cat. 109</p>

Catalogue No. : Cat. 110
 Group : Gr.2
 Type : Aa
 Body : Pinkish earthenware
 Glaze : white
 Decoration :
 Size (cm) : Height: 28.6; Diameter of mouth: 3.9;
 Diameter of base : 9.6.
 Unearthed From :
 Collected By : Guan Baocong collection
 Date (AD) : middle
 Published by : Lu Jing 2003, pl. 4-22.



Cat. 110

Catalogue No. : Cat. 111
 Group : Gr.2
 Type : Aa
 Body : Pinkish earthenware
 Glaze : white
 Decoration :
 Size (cm) : Height: 30.5.
 Unearthed From :
 Collected By : Guan Baocong collection
 Date (AD) : middle
 Published by : Lu Jing 2003, pl. 3-23.







Cat. 111

Catalogue No. : Cat. 112
 Group : Gr.2
 Type : Aa
 Body : Pinkish earthenware
 Glaze : green
 Decoration :
 Size (cm) : Height: 24.3.
 Unearthed From : BL4
 Collected By :
 Date (AD) : middle
 Published by : Wu Jiachang 1986, 32-51, fig.20.

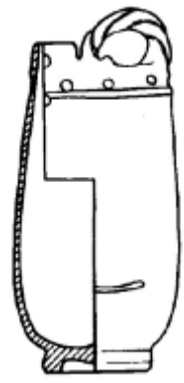
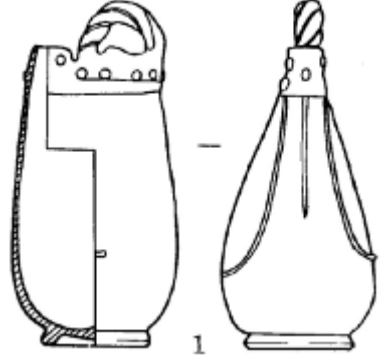

Cat. 112

<p>Catalogue No. : Cat. 113 Group : Gr.2 Type : Aa Body : Pinkish earthenware Glaze : Hell green Decoration : Size (cm) : Height: 26.4; Diameter of mouth: 3; Diameter of belly: 12.4; Diameter of base : 8.2. Unearthed From : SLG6 Collected By : Research Institute of Cultural Relics and Archaeology of Inner Mongolia Date (AD) : middle Published by : Neimenggu wenwu kaogu yanjiusuo 1997, 60-67, fig.4:2.</p>	 <p>Cat. 113</p>
<p>Catalogue No. : Cat. 114 Group : Gr.2 Type : Aa Body : Pinkish earthenware Glaze : Hell green Decoration : Size (cm) : Height: 27.6; Diameter of mouth: 3.2; Diameter of belly: 13.4; Diameter of base : 8.8. Unearthed From : SLG6 Collected By : Research Institute of Cultural Relics and Archaeology of Inner Mongolia Date (AD) : middle Published by : Neimenggu wenwu kaogu yanjiusuo 1997, 60-67, fig.4:1.</p>	 <p>Cat. 114</p>
<p>Catalogue No. : Cat. 115 Group : Gr.2 Type : Aa Body : Pinkish earthenware Glaze : White and green Decoration : Size (cm) : Height: 37.6. Unearthed From : Collected By : Meize Guan, Japan Date (AD) : Published by : Sugimura Yuzo 1974, Pl.2.</p>	 <p>Cat. 115</p>

<p>Catalogue No. : Cat. 116 Group : Gr.2 Type : Aa Body : Pinkish earthenware Glaze : green Decoration : Size (cm) : Height: 22.1. Unearthed From : Collected By : Tokyo national museum Date (AD) : Published by : Sugimura Yuzo 1974, Pl.32.</p>	 <p>Cat. 116</p>
<p>Catalogue No. : Cat. 117 Group : Gr.2 Type : Aa Body : Pinkish earthenware Glaze : White and green Decoration : Size (cm) : Height: 30.5. Unearthed From : Collected By : Tokyo national museum Date (AD) : Published by : Sugimura Yuzo 1974, Pl.31.</p>	 <p>Cat. 117</p>
<p>Catalogue No. : Cat. 118 Group : Gr.2 Type : Aa Body : Pinkish earthenware Glaze : White and green Decoration : Size (cm) : Height: 37.7; Diameter of mouth: 3.6; Diameter of belly: 17.2-15.8; Diameter of base : 11.6. Unearthed From : a tomb at Sanjiazi of Nangongyingzi, Kazuo county, Liaoning Collected By : Liaoning provincial museum Date (AD) : Published by : Zhongguo taoci quanji bianji weiyuanhui 1999, pl. 28; Shanghai renmin meishu chubanshe 1986, pl. 28; Liaoningsheng bowuguan 1961, pl. 2.</p>	 <p>Cat. 118</p>

Catalogue No. : Cat. 119
 Group : Gr.2
 Type : Aa
 Body : Pinkish earthenware
 Glaze : White and green
 Decoration :
 Size (cm) : Height: 39; Diameter of mouth: 3.2.
 Unearthed From : a tomb at Gongyingzi, Kazuo county, Liaoning
 Collected By : Liaoning provincial museum
 Date (AD) :
 Published by : Xu Bingkun & Sun Shoudao ed. 1998, pl.241; Shanghai renmin meishu chubanshe 1986, pl. 42.



Cat. 119

Catalogue No. : Cat. 120
 Group : Gr.2
 Type : Aa
 Body : Pinkish earthenware
 Glaze : White and green
 Decoration :
 Size (cm) : Height: 32.
 Unearthed From :
 Collected By : Kyusei Atami Museum
 Date (AD) :
 Published by : Mok 1985, pl. 20.



Cat. 120

Catalogue No. : Cat. 121
 Group : Gr.2
 Type : Aa
 Body : Pinkish earthenware
 Glaze : White and green
 Decoration :
 Size (cm) : Height: 34.5; Diameter of base : 9.5.
 Unearthed From : a tomb at Yousheng village, Baiyin aobao township, Balin Left Banner, Inner Mongolia
 Collected By : Liao shangjing museum
 Date (AD) :
 Published by : Tang Cailan 2005, pl. 54.



Cat. 121

Catalogue No. : Cat. 122
 Group : Gr.2
 Type : Aa
 Body : Pinkish earthenware
 Glaze : green
 Decoration :
 Size (cm) : Height: 30.4; Diameter of belly: 14.3-13.7;
 Diameter of base : 9.8.
 Unearthed From :
 Collected By : Liaoning provincial museum
 Date (AD) :
 Published by : Zhongguo taoci quanji bianji
 weiyuanhui 1999, pl. 93.



Cat. 122

Catalogue No. : Cat. 123
 Group : Gr.2
 Type : Aa
 Body : Pinkish earthenware
 Glaze : green
 Decoration :
 Size (cm) : Height: 25; Diameter of mouth: 3.8.
 Unearthed From : a tomb at Santai of Pingfangzi
 commune in Kazuo county, Liaoning
 Collected By : Kazuo museum, Liaoning
 Date (AD) :
 Published by : Shanghai renmin meishu chubanshe
 1986, pl. 14.



Cat. 123

Catalogue No. : Cat. 124
 Group : Gr.2
 Type : Aa
 Body : Pinkish earthenware
 Glaze : white
 Decoration :
 Size (cm) : Height: 23.4.
 Unearthed From : CGB11
 Collected By :
 Date (AD) : middle
 Published by : Dong Wenyi 1984, 91-93, fig.2:2.





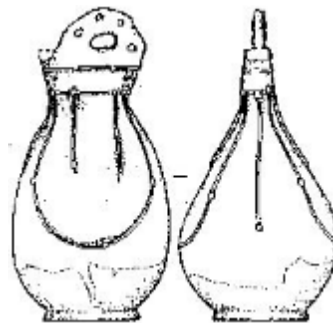

Cat. 124

Catalogue No. : Cat. 125
 Group : Gr.2
 Type : Aa
 Body : Pinkish earthenware
 Glaze : White and green
 Decoration :
 Size (cm) : Height: 33.4.
 Unearthed From : DSLT1
 Collected By :
 Date (AD) : middle
 Published by : Wan Xin 1999, 15-23, fig.6:4.

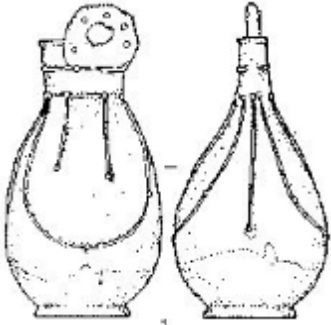

Cat. 125

<p>Catalogue No. : Cat. 126 Group : Gr.2 Type : Aa Body : Pinkish earthenware Glaze : White and green Decoration : Size (cm) : Height: 32. Unearthed From : DSLT1 Collected By : Date (AD) : middle Published by : Wan Xin 1999, 15-23, fig.6:1.</p>	 <p>Cat. 126</p>
<p>Catalogue No. : Cat. 127 Group : Gr.2 Type : Aa Body : Pinkish earthenware Glaze : White and green Decoration : Size (cm) : Height: 32. Unearthed From : Collected By : Xianggen meishuguan, Japan Date (AD) : Published by : Sugimura Yuzo,1974.</p>	 <p>Cat. 127</p>
<p>Catalogue No. : Cat. 128 Group : Gr.2 Type : Aa Body : Pinkish earthenware Glaze : White and brown Decoration : Size (cm) : Height: 27.5; Diameter of mouth: 2.7; Diameter of base: 8. Unearthed From : Collected By : Guan Baocong collection Date (AD) : Published by : Lu Jing 2003, pl. 4-201.</p>	 <p>Cat. 128</p>
<p>Catalogue No. : Cat. 129 Group : Gr.2 Type : Aa Body : Pinkish earthenware Glaze : White and green Decoration : Size (cm) : Height: 32; Diameter of mouth:15.5; Diameter of base: 11. Unearthed From : Collected By : Guan Baocong collection Date (AD) : Published by : Lu Jing 2003, pl. 4-196</p>	 <p>Cat. 129</p>

<p>Catalogue No. : Cat. 130 Group : Gr.2 Type : Aa Body : Pinkish earthenware Glaze : White and brown Decoration : Size (cm) : Height: 27; Diameter of mouth: 2.6; Diameter of base: 8. Unearthed From : Collected By : Guan Baocong collection Date (AD) : Published by : Lu Jing 2003, pl. 4-200</p>	 <p>Cat. 130</p>
<p>Catalogue No. : Cat. 131 Group : Gr.2 Type : Aa Body : Pinkish earthenware Glaze : green Decoration : Size (cm) : Height: 29.5; Diameter of mouth: 3.6; Diameter of base: 8.1. Unearthed From : Collected By : Guan baocong collection Date (AD) : Published by : Lu Jing 2003, pl. 4-152</p>	 <p>Cat. 131</p>
<p>Catalogue No. : Cat. 132 Group : Gr.2 Type : Aa Body : Pinkish earthenware Glaze : green Decoration : Size (cm) : Height: 30.8; Diameter of mouth: 2.9; Diameter of belly: 13.6-12.6; Diameter of base: 9.2. Unearthed From : Collected By : Liaoning provincial museum Date (AD) : Published by : Zhongguo taoci quanji bianji weiyuanhui 1999, pl. 77; Liaoningsheng bowuguan 1961, pl. 27</p>	 <p>Cat. 132</p>
<p>Catalogue No. : Cat. 133 Group : Gr.2 Type : Aa Body : Pinkish earthenware Glaze : green Decoration : Size (cm) : Height: 23.9; Diameter of mouth: 3.4; Diameter of base: 8.2. Unearthed From : Collected By : Guan baocong collection Date (AD) : Published by : Lu Jing 2003, pl. 4-153.</p>	 <p>Cat. 133</p>

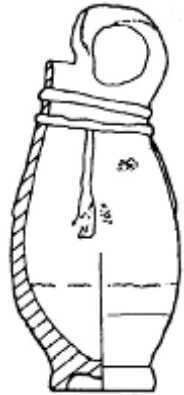
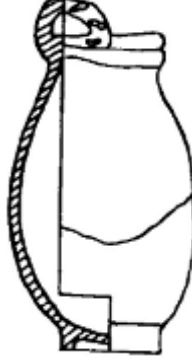
<p>Catalogue No. : Cat. 134 Group : Gr.2 Type : Aa Body : Pinkish earthenware Glaze : green Decoration : Size (cm) : Height: 29.1; Diameter of mouth: 3.6; Diameter of base: 8.1. Unearthed From : Collected By : Guan baocong collection Date (AD) : Published by : Lu Jing 2003, pl. 4-155.</p>	 <p>Cat. 134</p>
<p>Catalogue No. : Cat. 135 Group : Gr.2 Type : Aa Body : Pinkish earthenware Glaze : green Decoration : Size (cm) : Height: 29.8; Diameter of mouth: 2.2; Diameter of belly: 13.2; Diameter of base: 8.4. Unearthed From : a tomb at Kangjiazhangzi, Jianping, Liaoning Collected By : Research Institute of cultural relics and archaeology of Liaoning province Date (AD) : late Published by : Lü Xueming 1997, 24-29, fig.7:3.</p>	 <p>Cat. 135</p>
<p>Catalogue No. : Cat. 136 Group : Gr.2 Type : Aa Body : Pinkish earthenware Glaze : White and green Decoration : Size (cm) : Height: 16; Diameter of mouth: 2; Diameter of base: 5.5. Unearthed From : FJTGX Collected By : Chifeng municipal museum Date (AD) : late Published by : Aluke'erqin qi wenguansuo et al. 1996, 78-81, fig.4:6.</p>	 <p>Cat. 136</p>

Catalogue No. : Cat. 137
 Group : Gr.2
 Type : Aa
 Body : Pinkish earthenware
 Glaze : green
 Decoration :
 Size (cm) : Height: 21.
 Unearthed From : WLHD
 Collected By :
 Date (AD) : Late
 Published by : Wang Jianguo & Ma Junshan
 1986,74-76, fig.3:5.

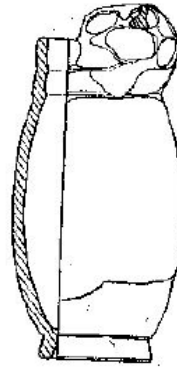

Cat. 137

Catalogue No. : Cat. 138
 Group : Gr.2
 Type : Aa
 Body : Pinkish earthenware
 Glaze : green
 Decoration :
 Size (cm) : Height: 20.5.
 Unearthed From : WLHD
 Collected By :
 Date (AD) : Late
 Published by : Wang Jianguo & Ma Junshan
 1986,74-76, fig.3:4.

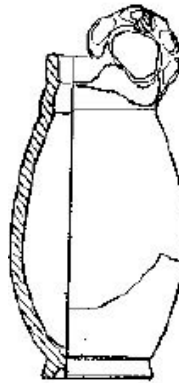



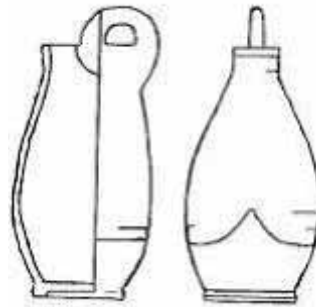

Cat. 138



Catalogue No. : Cat. 139
 Group : Gr.2
 Type : Aa
 Body : Pinkish earthenware
 Glaze : green
 Decoration :
 Size (cm) : Height: 16
 Unearthed From : CDM
 Collected By :
 Date (AD) : late
 Published by : Tian Li & Qi Xiaoguang 1981, 71-79,
 fig.2:1

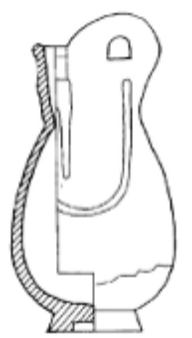

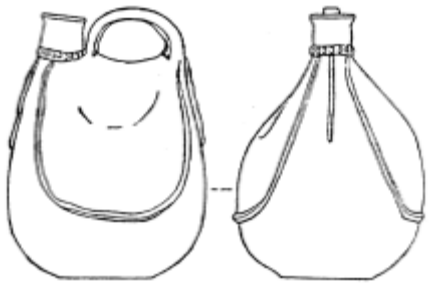

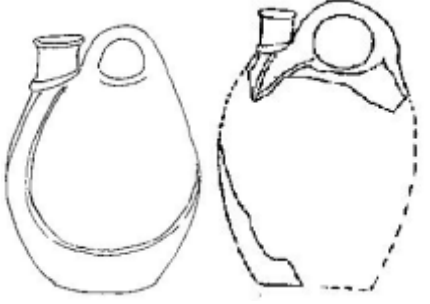
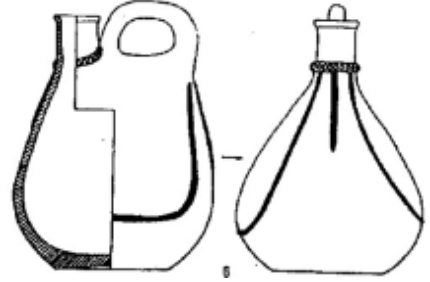

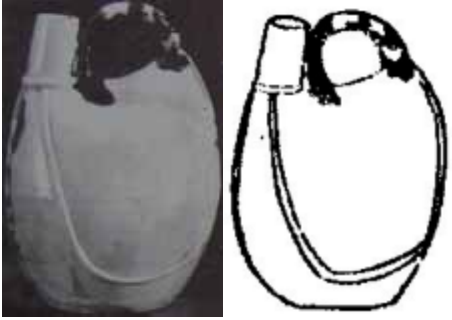
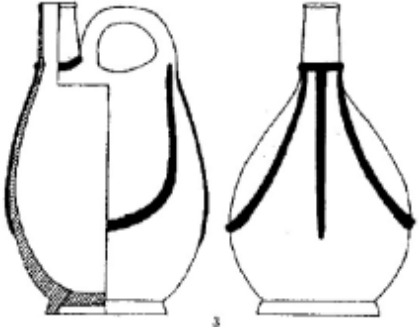
Cat. 139

<p>Catalogue No. : Cat. 140 Group : Gr.2 Type : Aa Body : Pinkish earthenware Glaze : White and green Decoration : Size (cm) : Height: 18.5; Diameter of mouth: 2.8; Diameter of base: 5.2. Unearthed From : a tomb at Shuangsheng village, Longchang county, Balin Left Banner, Inner Mongolia Collected By : Date (AD) : late Published by : Tang Cailan 2005, pl. 55-1</p>	 <p>Cat. 140</p>
<p>Catalogue No. : Cat. 141 Group : Gr.2 Type : Aa Body : Pinkish earthenware Glaze : yellow Decoration : Size (cm) : Height: 19; Diameter of mouth: 2.5; Diameter of base: 7. Unearthed From : Collected By : Guan Baocong collection Date (AD) : late Published by : Lu Jing 2003, pl. 4-140.</p>	 <p>Cat. 141</p>
<p>Catalogue No. : Cat. 142 Group : Gr.2 Type : Aa Body : Pinkish earthenware Glaze : White and green Decoration : Size (cm) : Height: 22. Unearthed From : Collected By : Tenri Museum, Nara Date (AD) : late Published by : Sugimura Yuzo 1974, pl. 34; Mok 1985, pl. 21.</p>	 <p>Cat. 142</p>
<p>Catalogue No. : Cat. 143 Group : Gr.2 Type : Aa Body : Pinkish earthenware Glaze : green Decoration : Size (cm) : Height: 24.6; Diameter of belly: 12.. Unearthed From : WJS1 Collected By : Chifeng municipal museum Date (AD) : Late Published by : Liu Bing et al.1998, 26-34, 38, fig.2:1.</p>	 <p>Cat. 143</p>

<p>Catalogue No. : Cat. 144 Group : Gr.2 Type : Ab Body : porcelain Glaze : white Decoration : Size (cm) : Height: 28. Unearthed From : HLB1 Collected By : Date (AD) : early Published by : Li Yufeng 1991, 106-19, 23, fig.3:14</p>	 <p>Cat. 144</p>
<p>Catalogue No. : Cat. 145 Group : Gr.2 Type : Ab Body : porcelain Glaze : white Decoration : Size (cm) : Height: 18.5.. Unearthed From : Collected By : Tokyo national museum Date (AD) : early Published by : Sugimura Yuzo 1974, pl.24; Mino Yukata et al. fig. 5.</p>	 <p>Cat. 145</p>
<p>Catalogue No. : Cat. 146 Group : Gr.2 Type : Ab Body : porcelain Glaze : white Decoration : Size (cm) : Height: 21. Unearthed From : MTYZ1 Collected By : Date (AD) : early Published by : Zheng Long 1981a, 231-243, fig.7:6; Mok 1985, fig.18b.</p>	 <p>Cat. 146</p>
<p>Catalogue No. : Cat. 147 Group : Gr.2 Type : Ab Body : porcelain Glaze : Tee-dust green Decoration : Size (cm) : Height: 26; Diameter of mouth: 4.5; Diameter of belly: 19.2; Diameter of base: 10.8. Unearthed From : a tomb at wusuyigen, Ganggen sumu, Balin Right Banner, Inner Mongolia Collected By : Balin Right banner museum Date (AD) : early Published by : Siri Guleng 2000, 110-13, fig.1:6.</p>	 <p>Cat. 147</p>

<p>Catalogue No. : Cat. 148 Group : Gr.2 Type : Ab Body : porcelain Glaze : White glaze and black pigment Decoration : Black painted dot on the handle Size (cm) : Height: 28. Unearthed From : CYZ Collected By : Date (AD) : early Published by : Liu Li 1994b, 104-9, pl.6:1.</p>	 <p>Cat. 148</p>
<p>Catalogue No. : Cat. 149 Group : Gr.2 Type : Ab Body : porcelain Glaze : white Decoration : Size (cm) : Height: 31.8; Diameter of mouth: 3.9; Diameter of belly: 21.6; Diameter of base: 13.2. Unearthed From : a tomb at Xiaochengzi village, Chagannuo sumu, Balin Right Banner, Inner Mongolia Collected By : Balin Right banner museum Date (AD) : early Published by : Siri Guleng 2000, 110-13, fig.1:3.</p>	 <p>Cat. 149</p>
<p>Catalogue No. : Cat. 150 Group : Gr.2 Type : Ab Body : porcelain Glaze : yellow Decoration : Size (cm) : Height: 21.3. Unearthed From : Collected By : Date (AD) : Published by : Lu Jing 2003, pl.3-35.</p>	 <p>Cat. 150</p>
<p>Catalogue No. : Cat. 151 Group : Gr.2 Type : Ab Body : porcelain Glaze : white Decoration : Incised peony design Size (cm) : Height: 27.3. Unearthed From : Collected By : Date (AD) : Published by : Lu Jing 2003, pl.3-38.</p>	 <p>Cat. 151</p>

<p>Catalogue No. : Cat. 152 Group : Gr.2 Type : Ab Body : porcelain Glaze : White glaze and black pigment Decoration : Size (cm) : Height: 21.4. Unearthed From : Collected By : Date (AD) : Published by : Lu Jing 2003, pl.3-37.</p>	 <p>Cat. 152</p>
<p>Catalogue No. : Cat. 153 Group : Gr.2 Type : Aa Body : porcelain Glaze : white Decoration : Raised ridges Size (cm) : Height: 22.8; Diameter of mouth: 3.2; Diameter of base: 7.5. Unearthed From : a tomb at Laopogou, Linjiadi township, Aohan Banner, Inner Mongolia Collected By : Aohan Banner museum Date (AD) : early Published by : Shao Guotian ed. 2004, 139-2.</p>	 <p>Cat. 153</p>
<p>Catalogue No. : Cat. 154 Group : Gr.2 Type : Ab Body : porcelain Glaze : white Decoration : Size (cm) : Height: 29.5. Unearthed From : QHM1 Collected By : Date (AD) : 1044 Published by : Li Wenxin 1954, 163-202, fig. 5:1.</p>	 <p>Cat. 154</p>
<p>Catalogue No. :Cat. 155 Group : Gr.2 Type : Ab Body : porcelain Glaze : white Decoration : Size (cm) : Height: 26.8. Unearthed From : YMT2 Collected By : Date (AD) : middle Published by : Feng Yongqian 1984a, 163-90, fig.2:4.</p>	 <p>Cat. 155</p>

<p>Catalogue No. : Cat. 156 Group : Gr.2 Type : Ab Body : porcelain Glaze : white Decoration : Size (cm) : Height: 28.9. Unearthed From : Collected By : Tokyo national museum Date (AD) : Published by : Sugimura Yuzo 1974, pl.35.</p>	 <p>Cat. 156</p>
<p>Catalogue No. : Cat. 157 Group : Gr.2 Type : Ab Body : porcelain Glaze : white Decoration : Size (cm) : Height: 27.9. Unearthed From : Collected By : Royal Ontario Museum, Toronto Date (AD) : Published by : Mino Yutaka et al. 1973, pl.110; Mino Yutaka et al.1971, 249, pl. 7.</p>	 <p>Cat. 157</p>
<p>Catalogue No. : Cat. 158 Group : Gr.2 Type : Ab Body : porcelain Glaze : white Decoration : Size (cm) : Height: 26.3; Diameter of mouth: 3; Diameter of base : 8.5. Unearthed From : Collected By : Guan Baocong collection Date (AD) : Published by : Lu Jing 2003, 4-20.</p>	 <p>Cat. 158</p>
<p>Catalogue No. : Cat. 159 Group : Gr.2 Type : Ab Body : porcelain Glaze : white Decoration : Size (cm) : Height: 24.3. Unearthed From : Collected By : Date (AD) : Published by : Mino Yutaka et al. 1973, pl.24.</p>	 <p>Cat. 159</p>

Catalogue No. : Cat. 160
 Group : Gr.2
 Type : Ab
 Body : porcelain
 Glaze : white
 Decoration :
 Size (cm) : Height: 32.
 Unearthed From : DYZ3
 Collected By :
 Date (AD) : middle
 Published by : Zheng Shaozong 1956, 1-26, pl.7:5.

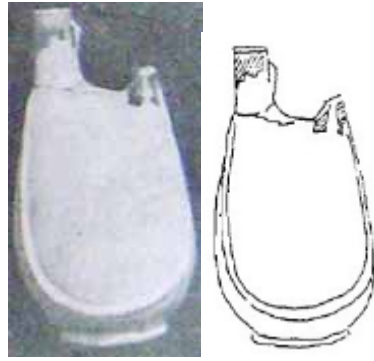

Cat. 160

Catalogue No. : Cat. 161
 Group : Gr.2
 Type : Ab
 Body : Pinkish earthenware
 Glaze : white
 Decoration : Brown painted
 Size (cm) : Height: 33; Diameter of mouth: 2.5;
 Diameter of base : 10.8.
 Unearthed From :
 Collected By : Guan Baocong collection
 Date (AD) :
 Published by : Lu Jing 2003, pl.4-198..



Cat. 161

Catalogue No. : Cat. 162
 Group : Gr.2
 Type : Ab
 Body : stoneware
 Glaze : white
 Decoration : Incised peony flower and leaves
 Size (cm) : Height: 28; Diameter of mouth: 3.2;
 Diameter of belly: 14.1-11.5; Diameter of base: 9.
 Unearthed From :
 Collected By : Liaoning provincial museum
 Date (AD) :
 Published by : Zhongguo taoci quanji bianji
 weiyuanhui 1999, pl.1; Xu Bingkun & Sun Shoudao
 ed. 1998, pl.240; Mok 1985, pl. 25.



Cat. 162

Catalogue No. : Cat. 163
 Group : Gr.2
 Type : Ab
 Body : stoneware
 Glaze : white
 Decoration : Incised peony flower and leaves
 Size (cm) : Height: 25.5.
 Unearthed From :
 Collected By : British Museum(1959 4-21)
 Date (AD) :
 Published by : Watson 1984, pl.267; Mok 1985, pl.
 23; Liaoningsheng bowuguan 1961, pl.26.



Cat. 163

Catalogue No. : Cat. 164
 Group : Gr.2
 Type : Ab
 Body : stoneware
 Glaze : white
 Decoration : Incised peony flower and leaves
 Size (cm) : Height: 26.8.
 Unearthed From :
 Collected By : Royal Ontario Museum, Toronto
 Date (AD) :
 Published by : Mino Yutaka et al. 1973, pl.111..



Cat. 164

Catalogue No. : Cat. 165
 Group : Gr.2
 Type : Ab
 Body : Pinkish earthenware
 Glaze : yellow
 Decoration :
 Size (cm) : Height: 29; Diameter of mouth: 2.7;
 Diameter of belly: 17.6; Diameter of base: 8.5.
 Unearthed From : a tomb at Bayanshana,
 Chaganmulun sum, Balin Right banner, Inner
 Mongolia
 Collected By : Balin Right Banner museum
 Date (AD) : late
 Published by : Siri Guleng 2000, 110-13, fig.1:2.



Cat. 165

Catalogue No. : Cat. 166
 Group : Gr.2
 Type : Ab
 Body : Pinkish earthenware
 Glaze : green
 Decoration :
 Size (cm) : Height: 31.5; Diameter of mouth: 3.
 Unearthed From :
 Collected By : Jinlin provincial museum
 Date (AD) : late
 Published by : Shanghai renmin meishu chubanshe
 1986, pl.129..



Cat. 166

Catalogue No. : Cat. 167
 Group : Gr.2
 Type : Ab
 Body : Pinkish earthenware
 Glaze : white
 Decoration :
 Size (cm) : Height: 24; Diameter of mouth: 2.4.
 Unearthed From : a tomb at Chutoulang commune,
 Chifeng city, Inner Mongolia
 Collected By : Chifeng wenhuaguan wenwuzu
 Date (AD) :
 Published by : Shanhai renmin meishu chubanshe
 1986, pl.166..



Cat. 167

Catalogue No. : Cat. 168
 Group : Gr.2
 Type : Ab
 Body : Pinkish earthenware
 Glaze : yellow
 Decoration :
 Size (cm) : Height: 17.5.
 Unearthed From : JFYZ
 Collected By :
 Date (AD) : late
 Published by : Xiang Chunsong 1979b, 330-4, fig.3:b;
 Mok 1985, fig. 17a.

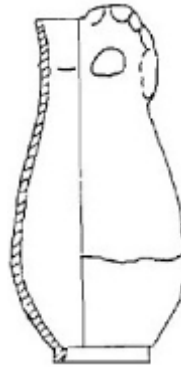

Cat. 168

Catalogue No. : Cat. 169
 Group : Gr.2
 Type : Ab
 Body : Pinkish earthenware
 Glaze : yellow
 Decoration :
 Size (cm) : Height: 34.
 Unearthed From : XBTB(MWG4)
 Collected By :
 Date (AD) : 1081
 Published by : Ji Ping & Ta La 1997, 609-30, fig.28:4.



Cat. 169

Catalogue No. : Cat. 170
Group : Gr.2
Type : Ab
Body : Pinkish earthenware
Glaze : white
Decoration :
Size (cm) : Height: 24.5; Diameter of mouth: 2.3.
Unearthed From :
Collected By : Liaoning provincial museum
Date (AD) :
Published by : Shanhai renmin meishu chubanshe
1986, pl.91.



Cat. 170

Catalogue No. : Cat. 171
Group : Gr.2
Type : Ab
Body : Pinkish earthenware
Glaze : green
Decoration :
Size (cm) : Height: 28; Diameter of mouth: 2.4.
Unearthed From :
Collected By : Liaoning Tieling qunzhongyishuguan
wenwuzu
Date (AD) :
Published by : Shanhai renmin meishu chubanshe
1986, pl.97.



Cat. 171

Catalogue No. : Cat. 172
Group : Gr.2
Type : Ab
Body : Pinkish earthenware
Glaze : yellow
Decoration :
Size (cm) : Height: 22.6; Diameter of mouth: 2.4.
Unearthed From :
Collected By : Liaoning provincial museum
Date (AD) :
Published by : Shanhai renmin meishu chubanshe
1986, pl.152.



Cat. 172

Catalogue No. : Cat. 173
 Group : Gr.2
 Type : Ab
 Body : Pinkish earthenware
 Glaze : green
 Decoration :
 Size (cm) : Height: 28.1; Diameter of mouth: 2.6;
 Diameter of belly: 14.2-13.8; Diameter of base: 8.
 Unearthed From :
 Collected By : Liaoning provincial museum
 Date (AD) :
 Published by : Liaoningsheng bowuguan 1961, pl. 3.



Cat. 173

Catalogue No. : Cat. 174
 Group : Gr.2
 Type : Ab
 Body : Pinkish earthenware
 Glaze : yellow
 Decoration :
 Size (cm) : Height: 31.3.
 Unearthed From : HPYZ1
 Collected By :
 Date (AD) : late
 Published by : Xiang Chunsong 1991, 33-9, fig.5:2.



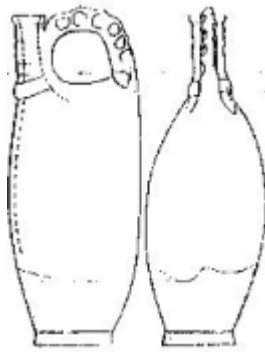

Cat. 174

Catalogue No. : Cat. 175
 Group : Gr.2
 Type : Ab
 Body : Pinkish earthenware
 Glaze : yellow
 Decoration :
 Size (cm) : Height: 28.5.
 Unearthed From : BL3
 Collected By :
 Date (AD) : late
 Published by : Wu Jiachang 1986, 32-51, fig.15:1.

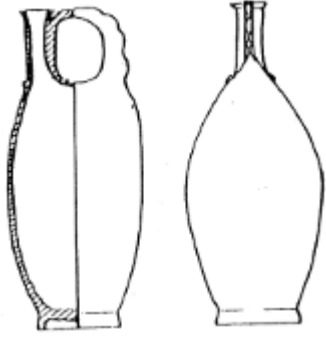
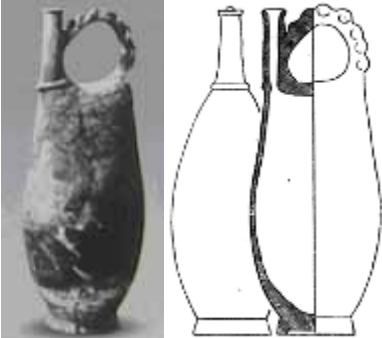

Cat. 175

<p>Catalogue No. : Cat. 176 Group : Gr.2 Type : Ab Body : Pinkish earthenware Glaze : yellow Decoration : Size (cm) : Height: 45. Unearthed From : PJG3 Collected By : Date (AD) : late Published by : Ji Ping 1997, 639-50, fig.8:1.</p>	 <p>Cat. 176</p>
<p>Catalogue No. : Cat. 177 Group : Gr.2 Type : Ab Body : Pinkish earthenware Glaze : green Decoration : Size (cm) : Height: 47.6 Unearthed From : QHM2 Collected By : Date (AD) : 1057 Published by : Li Wenxin 1954, 163-202, fig.10:3, pl.10:3.</p>	 <p>Cat. 177</p>
<p>Catalogue No. : Cat. 178 Group : Gr.2 Type : Ab Body : Pinkish earthenware Glaze : white Decoration : Size (cm) : Unearthed From : XDM Collected By : Date (AD) : late Published by : Xiang Chunsong 1991, 33-9, fig4:4.</p>	 <p>Cat. 178</p>

Catalogue No. : Cat. 179
Group : Gr.2
Type : Ab
Body : Pinkish earthenware
Glaze : yellow
Decoration :
Size (cm) : Height: 31
Unearthed From : LTL
Collected By :
Date (AD) : late
Published by : Duan Yiping 1983a.



Cat. 179

Catalogue No. : Cat. 180
Group : Gr.2
Type : Ab
Body : Pinkish earthenware
Glaze : yellow
Decoration :
Size (cm) : Height: 33; Diameter of mouth: 3.
Unearthed From :
Collected By : Jinlin provincial museum
Date (AD) : late
Published by : Shanghai renmin meishu chubanshe
1986, pl. 64.







Cat. 180

Catalogue No. : Cat. 181
Group : Gr.2
Type : Ab
Body : Pinkish earthenware
Glaze : white
Decoration :
Size (cm) : Height: 31.5; Diameter of mouth: 2.8.
Unearthed From :
Collected By : Liaoning tieling qunzhongyishuguan
wenwuzu
Date (AD) : late
Published by : Shanghai renmin meishu chubanshe
1986, pl. 108.

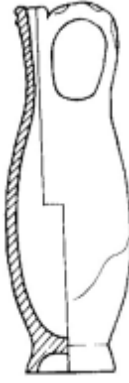
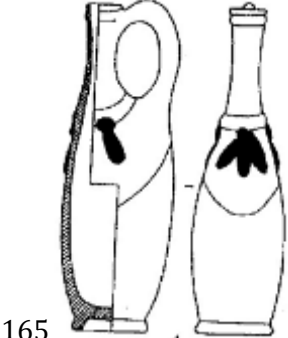

Cat. 181

<p>Catalogue No. : Cat. 182 Group : Gr.2 Type : Ab Body : Pinkish earthenware Glaze : yellow Decoration : Size (cm) : Height: 27 Unearthed From : WJS2 Collected By : Chifeng municipal museum Date (AD) : late Published by : Liu Bing et al. 1998, 26-34, 38, fig.6:3.</p>	 <p>Cat. 182</p>
<p>Catalogue No. : Cat. 183 Group : Gr.2 Type : Ab Body : Pinkish earthenware Glaze : brown Decoration : Size (cm) : Height: 32.1; Diameter of mouth: 3.3; Diameter of belly: 10.8; Diameter of base: 7.7. Unearthed From : a tomb at Erbadi, Yanchang township, Balin Right banner Collected By : Balin Right banner museum Date (AD) : late Published by : Siri Guleng 2000, 110-13, fig.1:4.</p>	 <p>165 Cat. 183</p>
<p>Catalogue No. : Cat. 184 Group : Gr.2 Type : Ab Body : Pinkish earthenware Glaze : Green Decoration : Size (cm) : Height: 28.3; Diameter of mouth: 4; Diameter of base: 11.4. Unearthed From : a tomb at Shuangsheng village, Longchang township, Balin Left banner Collected By : Liao shangjin museum, Inner Mongolia Date (AD) : late Published by : Tang Cailan 2005, pl. 55-2.</p>	 <p>Cat. 184</p>

<p>Catalogue No. : Cat. 185 Group : Gr.2 Type : Ab Body : stoneware Glaze : white Decoration : Size (cm) : Height: 17.9. Unearthed From : Collected By : Zhengmu museum, Japan Date (AD) : Published by : Sugimura Yuzo 1974, pl.36.</p>	 <p>Cat. 185</p>
<p>Catalogue No. : Cat. 186 Group : Gr.2 Type : Ab Body : Pinkish earthenware Glaze : yellow Decoration : Size (cm) : Height: 28. Unearthed From : BTYZ Collected By : Date (AD) : late Published by : Feng Yongqian 1960, 15-24.</p>	 <p>Cat. 186</p>
<p>Catalogue No. : Cat. 187 Group : Gr.2 Type : Ab Body : Pinkish earthenware Glaze : green Decoration : Size (cm) : Height: 30.6. Unearthed From : Collected By : Mr. Victor Hauge Falls Church, Virginia Date (AD) : Published by : Mino Yutaka et al. 1973, pl.16</p>	 <p>Cat. 187</p>

Catalogue No. : Cat. 188
Group : Gr.2
Type : Ab
Body : Pinkish earthenware
Glaze : yellow
Decoration :
Size (cm) : Height: 24.7.
Unearthed From :
Collected By : Royal Ontario Museum, Toronto
Date (AD) :
Published by : Mino Yutaka et al. 1973, pl.14

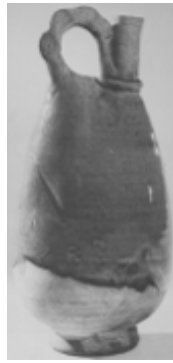

Cat. 188

Catalogue No. : Cat. 189
Group : Gr.2
Type : Ab
Body : Pinkish earthenware
Glaze : green
Decoration :
Size (cm) : Height: 33.5.
Unearthed From :
Collected By : Japanese private collection
Date (AD) :
Published by : Sugimura Yuzo 1974, pl.41





Cat. 189

Catalogue No. : Cat. 190
Group : Gr.2
Type : Ab
Body : Pinkish earthenware
Glaze : yellow
Decoration :
Size (cm) : Height:28.4.
Unearthed From :
Collected By : Japanese private collection
Date (AD) :
Published by : Sugimura Yuzo 1974, pl.39



Cat. 190

<p>Catalogue No. : Cat. 191 Group : Gr.2 Type : Ab Body : Pinkish earthenware Glaze : yellow Decoration : Size (cm) : Height: 32.4. Unearthed From : Collected By : Japanese private collection Date (AD) : Published by : Sugimura Yuzo 1974, pl.40</p>	 <p>Cat. 191</p>
<p>Catalogue No. : Cat. 192 Group : Gr.2 Type : Ab Body : Pinkish earthenware Glaze : yellow Decoration : Size (cm) : Height: 30; Diameter of mouth: 4.5. Unearthed From : a tomb at Pingfangzi, Kaozuo county, Chaoyang city, Liaoning Collected By : Kazuo museum, Liaoning Date (AD) : late Published by : Shanghai renmin meishu chubanshe 1986, pl.31.</p>	 <p>Cat. 192</p>
<p>Catalogue No. : Cat. 193 Group : Gr.2 Type : Ab Body : Pinkish earthenware Glaze : yellow Decoration : Size (cm) : Height: 29; Diameter of mouth: 2.5; Diameter of base: 7.5. Unearthed From : Collected By : Gugong bowuyuan, Beijing Date (AD) : late Published by : Zhongguo taoci quanji bianji weiyuanhui 1999, pl.63.</p>	 <p>Cat. 193</p>

Catalogue No. : Cat. 194
Group : Gr.2
Type : Ab
Body : Pinkish earthenware
Glaze : green
Decoration :
Size (cm) : Height: 30.9; Diameter of mouth: 2.9;
Diameter of base: 7.1.
Unearthed From :
Collected By : Guan Baocong collection
Date (AD) : late
Published by : Lu Jing 2003, pl. 4-150.



Cat. 194

Catalogue No. : Cat. 195
Group : Gr.2
Type : Ab
Body : Pinkish earthenware
Glaze : green
Decoration :
Size (cm) : Height: 32.
Unearthed From :
Collected By :
Date (AD) : late
Published by : Lu Jing 2003, pl. 3-46 left.







Cat. 195

Catalogue No. : Cat. 196
Group : Gr.2
Type : Ab
Body : Pinkish earthenware
Glaze : green
Decoration :
Size (cm) : Height: 31.9.
Unearthed From :
Collected By :
Date (AD) : late
Published by : Lu Jing 2003, pl. 3-46 right.



Cat. 196

<p>Catalogue No. : Cat. 197 Group : Gr.2 Type : Ab Body : Pinkish earthenware Glaze : yellow Decoration : Size (cm) : Height: 28; Diameter of belly: 14.1. Unearthed From : Collected By : Liaoning provincial museum Date (AD) : late Published by : Xu Bingkun & Sun Shoudao ed. 1998, pl. 239</p>	 <p>Cat. 197</p>
<p>Catalogue No. : Cat. 198 Group : Gr.2 Type : Ab Body : Pinkish earthenware Glaze : yellow Decoration : Size (cm) : Height: 25.8. Unearthed From : Collected By : Japanese private collection Date (AD) : Published by : Sugimura Yuzo 1974, pl.37</p>	 <p>Cat. 198</p>
<p>Catalogue No. : Cat. 199 Group : Gr.2 Type : Ab Body : Pinkish earthenware Glaze : green Decoration : Size (cm) : Height: 26.9. Unearthed From : Collected By : Japanese private collection Date (AD) : Published by : Sugimura Yuzo 1974, pl.4</p>	 <p>Cat. 199</p>
<p>Catalogue No. : Cat. 200 Group : Gr.2 Type : Ab Body : Pinkish earthenware Glaze : green Decoration : Size (cm) : Height: 28.8. Unearthed From : Collected By : Japanese private collection Date (AD) : Published by : Sugimura Yuzo 1974, pl.38</p>	 <p>Cat. 200</p>

Catalogue No. : Cat. 201
 Group : Gr.2
 Type : Ab
 Body : Pinkish earthenware
 Glaze : green
 Decoration :
 Size (cm) : Height: 27.9; Diameter of belly: 13.5-13.1;
 Diameter of base: 7.9.
 Unearthed From :
 Collected By : Liaoning provincial museum
 Date (AD) : late
 Published by : Zhongguo taoci quanji bianji
 weiyuanhui 1999, pl.85.



Cat. 201

Catalogue No. : Cat. 202
 Group : Gr.2
 Type : Ab
 Body : Pinkish earthenware
 Glaze : green
 Decoration :
 Size (cm) : Height: 31.5; Diameter of mouth: 3;
 Diameter of base: 7.5.
 Unearthed From :
 Collected By : Guan Baocong collection
 Date (AD) : late
 Published by : Lu Jing 2003, pl. 4-151.









Cat. 202

Catalogue No. : Cat. 203
 Group : Gr.2
 Type : Ab
 Body : Pinkish earthenware
 Glaze : yellow
 Decoration :
 Size (cm) : Height: 21; Diameter of mouth: 2.7;
 Diameter of base: 5.8.
 Unearthed From :
 Collected By : Guan Baocong collection
 Date (AD) : late
 Published by : Lu Jing 2003, pl. 4-138.



Cat. 203

<p>Catalogue No. : Cat. 204 Group : Gr.2 Type : Ab Body : Pinkish earthenware Glaze : yellow Decoration : Size (cm) : Height: 28.6; Diameter of mouth: 3.3; Diameter of base: 7.5. Unearthed From : Collected By : Guan Baocong collection Date (AD) : late Published by : Lu Jing 2003, pl. 4-136-1.</p>	 <p>Cat. 204</p>
<p>Catalogue No. : Cat. 205 Group : Gr.2 Type : Ab Body : Pinkish earthenware Glaze : green Decoration : Size (cm) : Height: 26.8. Unearthed From : Collected By : Brooklyn Museum, New York Date (AD) : late Published by : Mok 1985, pl. 22; Mino Yutaka et al. 1973, pl.12.</p>	 <p>Cat. 205</p>
<p>Catalogue No. : Cat. 206 Group : Gr.2 Type : Ab Body : stoneware Glaze : white Decoration : Size (cm) : Height: 30; Diameter of mouth: 3.8; Diameter of base: 9.1. Unearthed From : Collected By : Aohan Banner museum, Inner Mongolia Date (AD) : late Published by : Shao Guotian ed. 2004, pl. 138-1.</p>	 <p>Cat. 206</p>

<p>Catalogue No. : Cat. 207 Group : Gr.2 Type : Ab Body : Pinkish earthenware Glaze : yellow Decoration : Applied relief human with double heads and wings design Size (cm) : Height: 22. Unearthed From : a tomb at Shanzuizi village, Sanzuodian township, Ningcheng county, Inner Mongolia Collected By : Research institute of cultural relics and archaeology of Inner Mongolia Date (AD) : late Published by : Neimenggu zizhiqiu wenhuating & Zhongguo lishi bowuguan 2002, pl. 255.</p>	 <p>Cat. 207</p>
<p>Catalogue No. : Cat. 208 Group : Gr.2 Type : Ab Body : Pinkish earthenware Glaze : green Decoration : Incised peony design Size (cm) : Height: 27; Diameter of mouth: 2.4; Diameter of base: 8.5. Unearthed From : Collected By : Liaoshangjing museum, Inner Mongolia Date (AD) : late Published by : Tang Cailan 2005, pl. 52.</p>	 <p>Cat. 208</p>
<p>Catalogue No. : Cat. 209 Group : Gr.2 Type : Ab Body : Pinkish earthenware Glaze : green Decoration : Size (cm) : Height: 26.7. Unearthed From : Collected By : Royal Ontario Museum, Toronto Date (AD) : Published by : Mino Yutaka et al. 1973, pl.13</p>	 <p>Cat. 209</p>
<p>Catalogue No. : Cat. 210 Group : Gr.2 Type : Ab Body : Pinkish earthenware Glaze : yellow Decoration : Size (cm) : Height: 23.7. Unearthed From : Collected By : Philadelphia Museum of Art Date (AD) : Published by : Mino Yutaka et al. 1973, pl.15</p>	 <p>Cat. 210</p>

Catalogue No. : Cat. 211
Group : Gr.2
Type : Ab
Body : Pinkish earthenware
Glaze : yellow
Decoration :
Size (cm) : Height: 39.7.
Unearthed From :
Collected By : Japanese private collection
Date (AD) :
Published by : Sugimura Yuzo 1974, pl.42



Cat. 211

Catalogue No. : Cat. 212
Group : Gr.2
Type : Ab
Body : stoneware
Glaze : white
Decoration :
Size (cm) : Height: 27; Diameter of mouth: 3;
Diameter of base: 8.4.
Unearthed From :
Collected By : Guan Baocong collection
Date (AD) : late
Published by : Lu Jing 2003, pl. 4-21.











Cat. 212

Catalogue No. : Cat. 213
Group : Gr.2
Type : Ab
Body : Pinkish earthenware
Glaze : yellow
Decoration :
Size (cm) : Height: 26.7; Diameter of mouth: 2.7;
Diameter of base: 7.7.
Unearthed From :
Collected By : Guan Baocong collection
Date (AD) : late
Published by : Lu Jing 2003, pl. 4-139.



Cat. 213

<p>Catalogue No. : Cat. 214 Group : Gr.2 Type : Ab Body : Pinkish earthenware Glaze : yellow Decoration : Size (cm) : Height: 31.7; Diameter of mouth: 2.7; Diameter of base: 7. Unearthed From : Collected By : Guan Baocong collection Date (AD) : late Published by : Lu Jing 2003, pl. 4-137.</p>	 <p>Cat. 214</p>
<p>Catalogue No. : Cat. 215 Group : Gr.2 Type : Ab Body : Pinkish earthenware Glaze : green Decoration : Incised peony design Size (cm) : Height: 26.7; Diameter of mouth: 2.7; Diameter of base: 7.7. Unearthed From : Collected By : Guan Baocong collection Date (AD) : late Published by : Lu Jing 2003, pl. 4-216.</p>	 <p>Cat. 215</p>
<p>Catalogue No. : Cat. 216 Group : Gr.2 Type : Ab Body : Pinkish earthenware Glaze : green Decoration : Incised peony design Size (cm) : Height: 27; Diameter of mouth: 3; Diameter of base: 7.8. Unearthed From : Collected By : Guan Baocong collection Date (AD) : late Published by : Lu Jing 2003, pl. 4-171.</p>	 <p>Cat. 216</p>
<p>Catalogue No. : Cat. 217 Group : Gr.2 Type : Ab Body : porcelain Glaze : white Decoration : Size (cm) : Height: 23.5. Unearthed From : Collected By : Guan Baocong collection Date (AD) : late Potheod by Lu Jing:</p>	 <p>Cat. 217</p>

<p>Catalogue No. : Cat. 218 Group : Gr.2 Type : Ab Body : Pinkish earthenware Glaze : yellow Decoration : Size (cm) : Height: 23. Unearthed From : Collected By : Guangdong provincial museum Date (AD) : late Published by :</p>	 <p>Cat. 218</p>
<p>Catalogue No. : Cat. 219 Group : Gr.2 Type : B Body : porcelain Glaze : green Decoration : Size (cm) : Height: 20.7 Unearthed From : Collected By : Center of Asian Art and Culture, Avery Brundage Collection, San Francisco Date (AD) : early Published by : Mok 1985, pl.31; Mino Yutaka et al. 1973, pl.1; Watson 1984, pl.268.</p>	 <p>Cat. 219</p>
<p>Catalogue No. : Cat. 220 Group : Gr.2 Type : B Body : porcelain Glaze : White glaze with brown pigment Decoration : Applled relief and iron brown spotted Size (cm) : Height: 21.6. Unearthed From : Collected By : Victoria and Albert Museum,London Date (AD) : 8th century Published by : Mok 1985, pl.30.</p>	 <p>Cat. 220</p>
<p>Catalogue No. : Cat. 221 Group : Gr.2 Type : B Body : Pinkish earthenware Glaze : yellow Decoration : Raised ridge Size (cm) : Height: 15. Unearthed From : JSF Collected By : Capital museum, Beijing Date (AD) : late Published by : Shoudu bowuguan 1991, pl.38; Beijingshi wenwu guanlichu 1972, 35-40; Mok 1985, pl.32.</p>	 <p>Cat. 221</p>

Catalogue No. : Cat. 222
 Group : Gr.2
 Type : B
 Body : Pinkish earthenware
 Glaze : Green
 Decoration : Raised ridges and yellow pigment splashed.
 Size (cm) : Height: 20.4.
 Unearthed From :
 Collected By :
 Date (AD) : late
 Published by : Mok 1985, pl.33.



Cat. 222

Catalogue No. : Cat. 223
 Group : Gr.2
 Type : B
 Body : stoneware
 Glaze : white
 Decoration : Iron brown painted
 Size (cm) : Height: 18; Diameter of belly: 12-14;
 Diameter of base 7.5.
 Unearthed From :
 Collected By : Liaoning provincial museum
 Date (AD) : late
 Published by : Xu Bingkun & Sun Shoudao ed. 1998,
 pl.242; Zhongguo taoci quanji bianji weiyuanhui
 1999, pl.48; Liaoningsheng bowuguan 1961, pl. 25;
 Shanghai remin meishu chubanshe 1986, pl.44.



Cat. 223



Catalogue No. : Cat. 224
 Group : Gr.2
 Type : B
 Body : porcelain
 Glaze : white
 Decoration :
 Size (cm) :
 Unearthed From : a tomb at Xi'an, Shaanxi
 Collected By :
 Date (AD) : 8th century
 Published by : Li Zhiyan 1972a, 34-48, fig. 3:2.

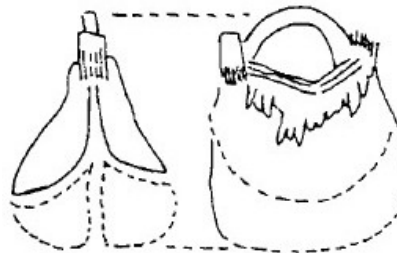

Cat. 224

Catalogue No. : Cat. 225
 Group : Gr.2
 Type : B
 Body : porcelain
 Glaze : white
 Decoration :
 Size (cm) :
 Unearthed From :
 Collected By :
 Date (AD) : 8th century
 Published by : Lu Jing 2003, 81, pl. 3-12.



Cat. 225

Catalogue No. : Cat. 226
 Group : Gr.2
 Type : B
 Body : porcelain
 Glaze : white
 Decoration :
 Size (cm) : 32.
 Unearthed From :
 Collected By : Guan Baocong collection
 Date (AD) : 8th century
 Photo by : Lu Jing





Cat. 226





Catalogue No. : Cat. 227
 Group : Gr.2
 Type : B
 Body : porcelain
 Glaze : white
 Decoration :
 Size (cm) : Height: 30.4.
 Unearthed From : a tomb at Xi'an, Shaanxi
 Collected By :
 Date (AD) : 8th century
 Published by : Lu Jing 2003, 81, pl. 3-13



Cat. 227

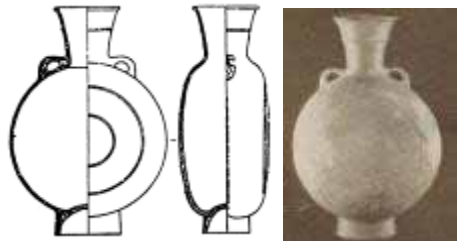



<p>Catalogue No. : Cat. 228 Group : Gr.2 Type : B Body : Porcelain Glaze : celadon Decoration : Size (cm) : Height: 20.4. Unearthed From : a tomb at Nantong city, Jiangsu province Collected By : Date (AD) : 8th century Published by : Lu Jing 2003, 81, pl. 3-14.</p>	 <p>Cat. 228</p>
<p>Catalogue No. : Cat. 229 Group : Gr.2 Type : B Body : Pinkish earthenware Glaze : Three-color glaze Decoration : Raised dots Size (cm) : Height: 19. Unearthed From : Collected By : Museum of Fine Arts: Hoyt Coll., Boston. Date (AD) : 8th century Published by : Mok 1985, pl. 29; Watson 1984, pl. 283.</p>	 <p>Cat. 229</p>
<p>Catalogue No. : Cat. 230 Group : Gr.2 Type : B Body : Pinkish earthenware Glaze : Three-color glaze Decoration : Raised dots Size (cm) : Height: 12.5. Unearthed From : Collected By : Tokyo national museum Date (AD) : 8th century Published by : Mok 1985, pl. 28.</p>	 <p>Cat. 230</p>

3.2 LUGGED PILGRIM FLASK

<p>Catalogue No. : Cat. 231 Type : Body : Grey pottery Glaze : Decoration : The two flat sides are decorated with raised concentric circles. Size (cm) : Height: 30. Unearthed From : HSN Collected By : Date : 9-10th century, early Liao or late Tang Published by : Zhang Baizhong 1983, 18-22, pl.2:4, fig.1:5.</p>	 <p>Cat. 231</p>
<p>Catalogue No. : Cat. 232 Type : Body : Grey pottery Glaze : Decoration : The two flat sides are decorated with raised concentric circles. Size (cm) : Height: 29.7 Unearthed From : ZKC4 Collected By : Date : 9-10th century, early Liao or late Tang Published by : Feng Yongqian 1981c, 65-70, fig.4; Liu Qian 1984, 990-1002.</p>	 <p>Cat. 232</p>
<p>Catalogue No. : Cat. 233 Type : Body : stoneware Glaze : brown Decoration : The two flat sides are decorated with raised concentric circles. Size (cm) : Height: 20. Unearthed From : Collected By : Guan Baocong collection Date : early Published by : Lu Jing 2003, pl. 3-144.</p>	 <p>Cat. 233</p>
<p>Catalogue No. : Cat. 234 Type : Body : Pinkishearthenware Glaze : brown Decoration : Raised concentric circles on flat sides, triangular patterns impressed within the circles and the scale patterns on the foot. Size (cm) : Height: 27.3; Diameter of belly: 25.4-9.1; Diameter of mouth: 7-3.9; Diameter of base: 8.7-5.4. Unearthed From : a tomb at Ningcheng, Inner Mongolia Collected By : Liaoning provincial museum Date : early Published by : Xu Bingkun & Sun Shoudao ed. 1998, pl. 232; Zhongguo taoci quanji bianji weiyuanhui, 199, pl.69; Liaoningsheng bowuguan, 1961, pl.39.</p>	 <p>Cat. 234</p>

<p>Catalogue No. : Cat. 235 Type : Body : Pinkishearthenware Glaze : brown Decoration : Raised concentric circles on flat sides, star-like combed curved lines within the circles. Size (cm) : Height: 36.6. Unearthed From : DQTL3 Collected By : Date : early Published by : Meng Jianren & Piao Chunyue 1997, 651-67, fig.7.</p>	 <p>Cat. 235</p>
<p>Catalogue No. : Cat. 236 Type : Body : Pinkishearthenware Glaze : green Decoration : Raised concentric circles on flat sides, triangular patterns impressed within the circles and the scale patterns on the foot. Size (cm) : Height: 26. Unearthed From : Collected By : Guan Baocong collection Date : early Published by : Photoed by Lu Jing</p>	 <p>Cat. 236</p>
<p>Catalogue No. : Cat. 237 Type : Body : Pinkishearthenware Glaze : green Decoration : Intagliod concentric circles on flat sides, star-like combed curved lines within the circles. Size (cm) : Height: 26. Unearthed From : GDG Collected By : Chifeng municipal museum, Inner Mongolia Date : middle I Published by : Xiang Chunsong 1989, 41-44, fig.9.</p>	 <p>Cat. 237</p>
<p>Catalogue No. : Cat. 238 Type : Body : stoneware Glaze : green Decoration : Incised concentric circles on flat sides, Size (cm) : Unearthed From : a tomb at Fanshan in Yuhang county, Zhejiang province Collected By : Date : 1-3th century Published by : Lu Jing 2003, pl.3-141.</p>	 <p>Cat. 238</p>
<p>Catalogue No. : Cat. 239 Type : Body : porcelain Glaze : yellow Decoration : Applied relief dancers and excutants Size (cm) : Height: 20.5. Unearthed From : the tomb of Fancui at Anyang city, Henan province Collected By : Date : 575 Published by : Lu Jing 2003, pl.3-142.</p>	 <p>Cat. 239</p>

3.3 LUGGED VASE

<p>Catalogue No. : Cat. 240 Type : A Body : porcelain Glaze : white Decoration : Size (cm) : Height: 23.3. Unearthed From : DQTL3 Collected By : Date (AD) : early Published by : Meng Jianren & Piao Chunyue 1997, 651-67, fig.8:3.</p>	 <p>Cat. 240</p>
<p>Catalogue No. : Cat. 241 Type : A Body : porcelain Glaze : white Decoration : Three indented lines decorate the shoulder; on opposite sides of the body are raised double straps that extend from the shoulder to the bottom of the body. At the top and bottom of each pair of straps are two horizontal bridge-shaped loops. Size (cm) : Height: 23.3. Unearthed From : YLYZ Collected By : Date (AD) : 942 Published by : Qi Xiaoguang et al. 1996, 4-32, fig.49; Zhongguo taoci quanji bianji weiyuanhui 1999, pl.6; Neimenggu zizhiqiu wenhuating & Zhongguo lishi bowuguan 2002, pl.235; Shen Hsueh-man 2006, pl.105.</p>	 <p>Cat. 241</p>
<p>Catalogue No. : Cat. 242 Type : A Body : Pinkish earthen ware Glaze : White glazed with green splashes Decoration : Size (cm) : Height: 30; Diameter of mouth: 7.1; Diameter of belly: 17.4; Diameter of base: 9.9. Unearthed From : Collected By : Liaoning provincial museum Date (AD) : Probably 11th century Published by : Liaoningsheng bowuguan 1961, pl. 40; Shanhai renmin meishu chubanshe ed. 1986, pl. 151.</p>	 <p>Cat. 242</p>
<p>Catalogue No. : Cat. 243 Type : B Body : porcelain Glaze : white Decoration : Size (cm) : Height: 36.8. Unearthed From : ZKC1 Collected By : Date (AD) : early Published by : Liu Qian 1984, 990-1002; Feng Yongqian 1981c, 65-71, fig.11.</p>	 <p>Cat. 243</p>

<p>Catalogue No. : Cat. 244 Type : B Body : Buff stoneware Glaze : green Decoration : Size (cm) : Height: 31. Unearthed From : MTYZ2 Collected By : Date (AD) : early Published by : Zheng Long 1981,231-243, fig. 8:1</p>	 <p>Cat. 244</p>
<p>Catalogue No. : Cat. 245 Type : BI Body : porcelain Glaze : white Decoration : Guan mark Size (cm) : Height: 28.5; Diameter of mouth: 12; Diameter of belly: 20. Unearthed From : a tomb at Baoquan village, Balin Left banner, Inner Mongolia. Collected By : Liaoshangjing museum, Inner Mongolia Date (AD) : early Published by : Tang Cailan 2005, pl. 59.</p>	 <p>Cat. 245</p>
<p>Catalogue No. : Cat. 246 Type : BI Body : Buff stoneware Glaze : green Decoration : Size (cm) : Height: 29. Unearthed From : a tomb at Bolochi, Chaoyang, Liaoning Collected By : Date (AD) : early Published by : Feng Yongqian 1981c,65-71, fig.10.</p>	 <p>Cat. 246</p>
<p>Catalogue No. : Cat. 247 Type : B Body : Buff stoneware Glaze : yellow Decoration : Stamped design Size (cm) : Height: 32.6; Diameter of mouth: 9.3 Unearthed From : a tomb at Tuchengzi, Helinge'er county, Huhhot, Inner Mongolia Collected By : Inner Mongolia Autonomous Region Museum Date (AD) : early Published by : Neimenggu zizhiqiu wenwu gongzuodui, 1961, 30-33, fig.1; Zhonghua shiji tan & Neimenggu bowuguan 2004, pl. 171.</p>	 <p>Cat. 247</p>

Catalogue No. : Cat. 248
 Type : B
 Body : Buff stoneware
 Glaze : yellow
 Decoration : Stamped design
 Size (cm) : Height: 32.4.
 Unearthed From : a tomb at Shantiaomao, Qinshuihe, Inner Mongolia
 Collected By :
 Date (AD) : early
 Published by : Wei Jian 1997,20-35, fig.27:1.

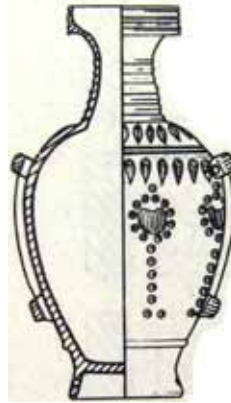

Cat. 248

Catalogue No. : Cat. 249
 Type : B
 Body : Buff stoneware
 Glaze : Green
 Decoration : Incised lines decorate the mouth rim and shoulder. Incised ridges mark the neck. Three rows of applique leaf-shapes encircle the shoulder, and six tassel-like forms and circular beads in applique together with additional incised patterns decorate the main body. A groove runs in a straight line from the shoulder down the body, and a pair of lugs project from both ends of the groove. Further down, on the foot-ring, but still in line with the lugs, are two rectangular holes through which a rope could be fastened, so that the bottle could be transported. In the 10th century, tassel design was not only seen on ceramics but also used as architectural decoration. For example, three balls with long red tassels were painted above a niche in the east side chamber of the tomb (dated 958) of Feng Hui in Xianyang, Shaanxi Province.
 Size (cm) : Height: 29.5; Diameter of belly: 22.3.
 Unearthed From : YLYZ
 Collected By : Research institute of cultural relics and archaeology of Inner Mongolia
 Date (AD) : 942
 Published by : Qi Xiaoguang et al. 1996, 4-32, fig.51; Shen Hsueh-man 2006, pl.76; Neimenggu zizhiqu wenhuating & Zhongguo lishi bowuguan 2002, pl.232.





Cat. 249



Catalogue No. : Cat. 250
 Type : B
 Body : Buff stoneware
 Glaze : Green
 Decoration : Six raised rings around the broken neck. Mouth and part of the foot have been cut off. A raised band encircles lower body. Two rows of applique leaf-shapes encircle the shoulder. At opposite sides of the body are raised double straps from shoulder to lower body. The strap ends are covered by transversely grooved loops. Shoulder decorated with two bands of molded leaves, the bands being divided by four incised lines. Central body has six shell-like designs at intervals, each shell surrounded by "fish-egg" style circles similar to those found in Tang silver works. These circles extend also vertically from top and bottom of the shells.
 Size (cm) : Height: 28.
 Unearthed From :
 Collected By : The Detroit Institute of Arts, gift of Edgar Worch
 Date (AD) : early
 Published by : Mino Yutaka et al. 1973, pl. 52.

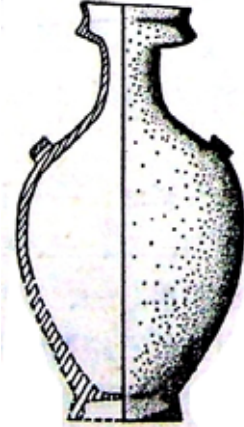



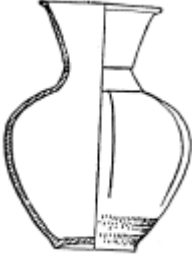

Cat. 250

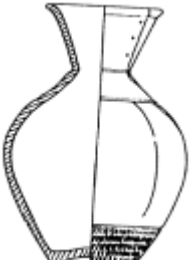
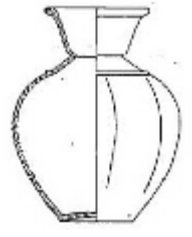

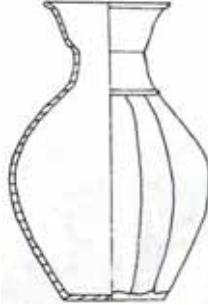
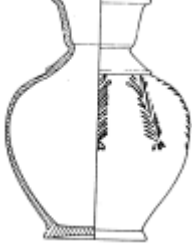
<p>Catalogue No. : Cat. 251 Type : B Body : Buff stoneware Glaze : Green Decoration : Two rows of applique leaf-shapes circle the shoulder, and six tassel-like forms and circular dots in applique together with additional incised patterns decorate the main body. A pair of tunnel- shaped lugs project in a straight line from the shoulder and body below. Further down the foot ring but still in line with the lugs are two rectangular holes. These are linked by a groove that runs from shoulder to foot ring. Size (cm) : Height: 32.5. Unearthed From : Collected By : Mengdiexuan collection Date (AD) : Published by : So, Jenny F. 2004, pl. : 8.</p>	 <p>Cat. 251</p>
<p>Catalogue No. : Cat. 252 Type : B Body : Buff stoneware Glaze : Black Decoration : Size (cm) : Height : 50.4. Unearthed From : DST3 Collected By : Date (AD) : early Published by : Zheng Long 1981, 95-101, fig.7:5.</p>	 <p>Cat. 252</p>
<p>Catalogue No. : Cat. 253 Type : Body : porcelain Glaze : white Decoration : Two wide lobes separated by two narrow lobes on the body. Attached loops at upper and lower ends of the narrow lobes. Size (cm) : Height: 23.3. Unearthed From : Collected By : Center of Asian Art and Culture, Avery Brundage Collection, San Francisco, California Date (AD) : Tang Published by : Mino Yutaka et al. 1973, pl. 38.</p>	 <p>Cat. 253</p>

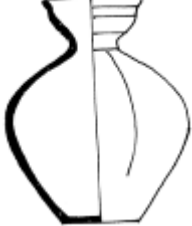
3.4 BOWL-MOUTH BOTTLE

<p>Catalogue No. : Cat. 254 Type : A Body : Pottery Glaze : Decoration : Size (cm) : Height: 23. Unearthed From : DHG1 Collected By : Date (AD) : early Published by: Shao Guotian 1987, 899-904.</p>	 <p>Cat. 254</p>
<p>Catalogue No. : Cat. 255 Type : A Body : Pottery Glaze : Decoration : Size (cm) : Height: 24. Unearthed From : HSN Collected By : Date (AD) : early Published by: Zhang Baizhong 1983, 18-22, fig.1:1.</p>	 <p>Cat. 255</p>
<p>Catalogue No. : Cat. 256 Type : A Body : Pottery Glaze : Decoration : Size (cm) : Height: 26. Unearthed From : NZLYZ1 Collected By : Date (AD) : early Published by: Liaoningsheng wenwu kaogu yanjiusuo et al. 1992, 54-63, fig. 3:2.</p>	 <p>Cat. 256</p>
<p>Catalogue No. : Cat. 257 Type : A Body : Pottery Glaze : Decoration : Size (cm) : Height: 26. Unearthed From : A tomb at Wurigentala, Zhalute Banner, Inner Mongolia Collected By : Date (AD) : early Published by: Zhelimumeng bowuguan 1984, 153-56, fig.2:1.</p>	 <p>Cat. 257</p>

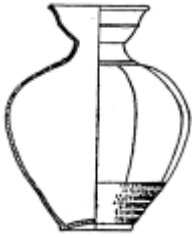
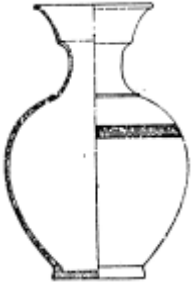
<p>Catalogue No. : Cat. 258 Type : A Body : Stoneware Glaze : white Decoration : Size (cm) : Height: 30. Unearthed From : A tomb at Wujianfang, Linxi County, Inner Mongolia Collected By : Date (AD) : early Published by: Wang Gang & Lü Qing 2001, 124-6, fig.3:2.</p>	 <p>Cat. 258</p>
<p>Catalogue No. : Cat. 259 Type : A Body : Stoneware Glaze : brown Decoration : Size (cm) : Height: 27.5. Unearthed From : NZLYZ1 Collected By : Date (AD) : early Published by: Liaoningsheng wenwu kaogu yanjiusuo et al. 1992, 54-63, fig. 3:6.</p>	 <p>Cat. 259</p>
<p>Catalogue No. : Cat. 260 Type : A Body : Pottery Glaze : Decoration : Size (cm) : Height: 22.4. Unearthed From : A tomb at Sandaohao, Liaoyang city, Liaoning Province Collected By : Date (AD) : early Published by: Li Qingfa 1981, 41-42, fig. 2:2.</p>	 <p>Cat. 260</p>
<p>Catalogue No. : Cat. 261 Type : A Body : Pottery Glaze : Decoration : Size (cm) : Height: 24. Unearthed From : EBD1 Collected By : Date (AD) : early Published by: Xiang Chunsong 1984, 80-90, fig.2:5.</p>	 <p>Cat. 261</p>

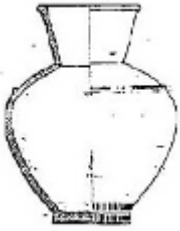

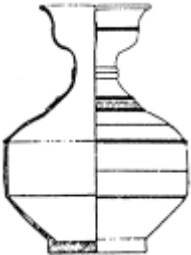
<p>Catalogue No. : Cat. 262 Type : A Body : Pottery Glaze : Decoration : Size (cm) : Height: 24.3; Diameter of mouth: 11.5.. Unearthed From : A tomb at Rezhong commune of keshiketeng Banner, Inner Mongolia Collected By : Chifeng municipal museum Date (AD) : early Published by: Shanghai renmin meishu chubanshe 1986, pl. 123.</p>	 <p>Cat. 262</p>
<p>Catalogue No. : Cat. 263 Type : A Body : Pottery Glaze : Decoration : Size (cm) : Height: 31.3; Diameter of mouth: 13.7; Diameter of base: 10.7.. Unearthed From : YLYZ Collected By : Research institute of cultural relics and archaeology of Inner Mongolia Date (AD) : 942 Published by: Shen Hsueh-man 2006, pl.11.</p>	 <p>Cat. 263</p>
<p>Catalogue No. : Cat. 264 Type : A Body : Pottery Glaze : Decoration : Size (cm) : Height: 38.5. Unearthed From : SZG1 Collected By : Date (AD) : early Published by: Shao Guotian 1987, 889-904.</p>	 <p>Cat. 264</p>
<p>Catalogue No. : Cat. 265 Type : B Body : Stoneware Glaze : yellow Decoration : Size (cm) : Height: 28.8. Unearthed From : HSN Collected By : Date (AD) : early Published by: Zhang Baizhong 1983, 18-22, fig.1:6.</p>	 <p>Cat. 265</p>





<p>Catalogue No. : Cat. 266 Type : B Body : Pottery Glaze : Decoration : Size (cm) : Height: 16. Unearthed From : Tomb at Liutiaogou, Beipiao, Liaoning Collected By : Date (AD) : early Published by: Feng Yonqian 1981, 36-40, fig. 2:1.</p>	 <p>Cat. 266</p>
<p>Catalogue No. : Cat. 267 Type : B Body : Stoneware Glaze : brown Decoration : Size (cm) : Height: 33.4; Diameter of mouth: 14.3; Diameter of base: 10.5. Unearthed From : YLYZ Collected By : Research institute of relics and archaeology of Inner Mongolia Date (AD) : 942 Published by: Neimenggu zizhiqu wenhuating & Zhongguo lishi bowuguan 2002, pl. 242; Qi Xiaoguang et al. 1996, 4-32, fig.48:2.</p>	 <p>Cat. 267</p>
<p>Catalogue No. : Cat. 268 Type : C Body : Stoneware Glaze : yellow Decoration : Size (cm) : Height: 25.5 Unearthed From : HSN Collected By : Date (AD) : early Published by: Zhang Baizhong 1983, 18-22, fig.1:2.</p>	 <p>Cat. 268</p>

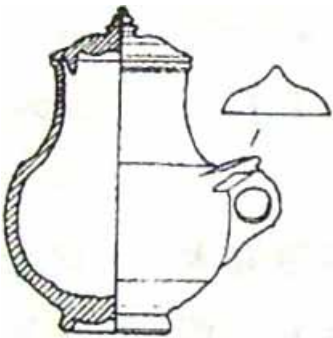
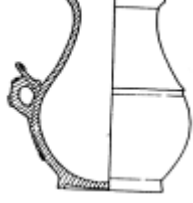

3.5 CARINATE SHOULDER BOTTLE



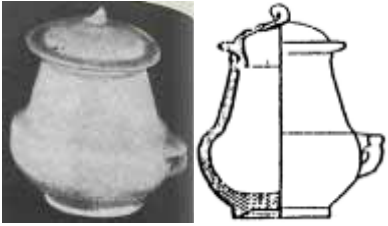

<p>Catalogue No. : Cat. 269 Type : A Body : Gilt silver Glaze : Decoration : Floral motifs in low relief decorate the body. Size (cm) : ? Unearthed From : MTYZ1 Collected By : Date (AD) : Published by: Zheng Long 1981, 231-43.</p>	 <p>Cat. 269</p>
---	--

<p>Catalogue No. : Cat. 270 Type : A Body : Gold Glaze : Decoration : Floral motifs in low relief decorate he body. Size (cm) : Unearthed From : Kebinei Collected By : Date (AD) : Published by:</p>	 <p>Cat. 270</p>
<p>Catalogue No. : Cat. 271 Type : A Body : Gold Glaze : Decoration : Floral motifs in low relief decorate he body. Size (cm) : Height: 13.5. Unearthed From : Collected By : Privat collection Date (AD) : Published by: Zhang Jingming 2005, pl. 137.</p>	 <p>Cat. 271</p>
<p>Catalogue No. : Cat. 272 Type : A Body : Gilt silver Glaze : Decoration : Floral motifs in low relief decorate the flange. The body is plain and the gilding is severely worn. Size (cm) : Hight: 11; Diameter of mouth: 5.5. Unearthed From : Collected By : Mengdiexuan collection, HongKong Date (AD) : Published by: So 2004, pl. : 9.</p>	 <p>Cat. 272</p>
<p>Catalogue No. : Cat. 273 Type : A Body : Silver Glaze : Decoration : Size (cm) : Height: 11.2; Diameter of mouth: 6.5. Unearthed From : Tomb at Lijiayingzi, Kangjiayingzi Township, Aohan Banner, Inner Mongolia. Collected By : Aohan Banner Museum, Inner Mongolia Date (AD) : Published by: Shao Guotian ed. 2004, pl. 97.</p>	 <p>Cat. 273</p>

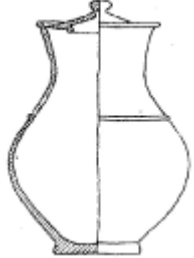
<p>Catalogue No. : Cat. 274 Type : A Body : Pinkish earthenware Glaze : green Decoration : Impressed floral designs on the neck. Size (cm) : Height: 19.5. Unearthed From : HLB1 Collected By : Date (AD) : early Published by: Li Yufeng 1991, 106-19, fig.4:1.</p>	 <p>Cat. 274</p>
<p>Catalogue No. : Cat. 275 Type : A Body : Pinkish earthenware Glaze : green Decoration : Size (cm) : Height: 18.5. Unearthed From : Chifeng city, Inner Mongolia Collected By : Chifeng municipal antique shop Date (AD) : early Published by: Neimenggu zizhiqu wenhuating & Zhongguo lishi bowuguan 2002, pl. 270.</p>	 <p>Cat. 275</p>
<p>Catalogue No. : Cat. 276 Type : A Body : Pinkish earthenware Glaze : green Decoration : Size (cm) : Height: 16; Diameter of mouth: 7.2; Diameter of base: 5.8. Unearthed From : Tomb at Chaoyanggou, Zhangwu city, Liaoning province Collected By : Zhangwu municipal relics office. Date (AD) : early Published by: Li Yufeng et al. 2003, 83-111, fig. 26:4.</p>	 <p>Cat. 276</p>
<p>Catalogue No. : Cat. 277 Type : A Body : Buff stoneware Glaze : white Decoration : Size (cm) : Height: 15.5. Unearthed From : NZLYZ1 Collected By : Date (AD) : early Published by: Liaoningsheng wenwu kaogu yanjiusuo et al. 1992, 54-63, fig.3:1.</p>	 <p>Cat. 277</p>





<p>Catalogue No. : Cat. 278 Type : A Body : Buff stoneware Glaze : white Decoration : Size (cm) : Height: 15. Unearthed From : QJZ Collected By : Fuxinshi wenhuaju wenwuzu, Liaoning province Date (AD) : early Published by: Zhao Zhensheng & Bai Jie 1995, 1008-12, fig.3:1.</p>	 <p>Cat. 278</p>
<p>Catalogue No. : Cat. 279 Type : A Body : Pinkish earthenware Glaze : green Decoration : Size (cm) : Height: 20.8. Unearthed From : Collected By : Privat collection Date (AD) : Published by: Lu Jing 2003, 3-124.</p>	 <p>Cat. 279</p>
<p>Catalogue No. : Cat. 280 Type : A Body : Pinkish earthenware Glaze : green Decoration : Size (cm) : Height: 17. Unearthed From : a tomb at Pingquan County, Hebei Province. Collected By : Pinquan prefectural Museum, Hebei Province. Date (AD) : middle Published by: Liu Zilong & Wang Ye 1998, 74,78.</p>	 <p>Cat. 280</p>
<p>Catalogue No. : Cat. 281 Type : A Body : Pinkish earthenware Glaze : green Decoration : Size (cm) : Height: 18. Unearthed From : GDG Collected By : Chifeng municipal museum Date (AD) : middle Published by: Xiang Chunsong 1989, 41-44.</p>	 <p>Cat. 281</p>





<p>Catalogue No. : Cat. 282 Type : A Body : Porcelain Glaze : white Decoration : Size (cm) : Height: 7.8, Unearthed From : HYM Collected By : Date (AD) : 997 Published by: Huang Xiuchun et al. 1984, 361-81, fig.6:10.</p>	 <p>Cat. 282</p>
<p>Catalogue No. : Cat. 283 Type : B Body : Gold Glaze : Decoration : Floral motifs in low relief decorate the body. Size (cm) : Height: 14.8; Diameter of mouth: 7.6. Unearthed From : Kebinei Collected By : Research institute of relics and archaeology of Inner Mongolia Date (AD) : early Published by: Zhang Jingming 2005, pl. 95.</p>	 <p>Cat. 283</p>
<p>Catalogue No. : Cat. 284 Type : B Body : Polished black pottery Glaze : Decoration : Stilted deer designs on the belly. Size (cm) : Height: 22, Diameter of mouth: 10.4; Diameter of base: 9. Unearthed From : Collected By : Aohan museum , Inner Mongolia Date (AD) : early Published by: Shao Guotian ed. 2004, pl. 123.</p>	 <p>Cat. 284</p>
<p>Catalogue No. : Cat. 285 Type : B Body : Pinkish earthenware Glaze : black Decoration : Size (cm) : Height: 22(with cover 24); Diameter of mouth: 11.6; Diameter of belly: 17.2; Diameter of base: 9.2. Unearthed From : ZJY1 Collected By : Date (AD) : early Published by: Pei Yaojun 1996, 57-67, fig. 3:1.</p>	 <p>Cat. 285</p>





<p>Catalogue No. : Cat. 286 Type : B Body : Porcelain Glaze : white Decoration : Incised "Guan" mark inscription on the base. Size (cm) : Unearthed From : KPYZ1 Collected By : Date (AD) : early Published by: Liaoning Chaoyang diqu wenwuzu 1978, 129-34.</p>	 <p>Cat. 286</p>
<p>Catalogue No. : Cat. 287 Type : B Body : Stoneware Glaze : white Decoration : Size (cm) : Height: 21.5; Diameter of mouth: 9.5; Diameter of base: 9. Unearthed From : Collected By : Aohan Banner museum Date (AD) : Published by: Shao Guotian ed. 2004, pl. 146.</p>	 <p>Cat. 287</p>
<p>Catalogue No. : Cat. 288 Type : B Body : Pinkish earthenware Glaze : yellow Decoration : Incised peony designs on the belly. Size (cm) : Height: 18.2. Unearthed From : Collected By : Privat collection Date (AD) : late Published by: Lu Jing 2003, pl. 3-127.</p>	 <p>Cat. 288</p>
<p>Catalogue No. : Cat. 289 Type : B Body : Buff stoneware Glaze : white Decoration : Carved peony designs on the belly. Size (cm) : Height: 32; Diameter of mouth: 13; Diameter of base: 12. Unearthed From : Collected By : Guan Baocong collection Date (AD) : late Published by: Lu Jing 2003, pl. 4-225.</p>	 <p>Cat. 289</p>

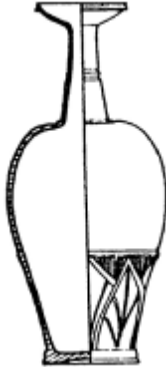

<p>Catalogue No. : Cat. 290 Type : B Body : Pinkish earthenware Glaze : green Decoration : Size (cm) : Height: 24; Diameter of mouth: 9.5; Diameter of base: 8.2. Unearthed From : Collected By : Liaoshangjing museum, Inner Mongolia Date (AD) : Published by: Tang Cailan 2005, pl. 65-2.</p>	 <p>Cat. 290</p>
<p>Catalogue No. : Cat. 291 Type : B Body : Pinkish earthenware Glaze : Yellow and green Decoration : Incised peony designs on the belly Size (cm) : Height: 18.9; Diameter of mouth: 8.4; Diameter of base: 6.9. Unearthed From : Collected By : Guan Baocong collection Date (AD) : late Published by: Lu Jing 2003, pl. 4-203.</p>	 <p>Cat. 291</p>
<p>Catalogue No. : Cat. 292 Type : B Body : stoneware Glaze : white Decoration : carved vertical lines on the belly Size (cm) : Height: 13.9; Diameter of mouth: 6.6; Diameter of belly: 10.7; Diameter of base: 6.5. Unearthed From : Collected By : Liaoning Provincial Museum Date (AD) : late Published by: Liaoningsheng bowuguan 1961, pl. 55.</p>	 <p>Cat. 292</p>

3.6 LONG-NECK VASE



<p>Catalogue No. : Cat. 293 Type : A Body : porcelain Glaze : white Decoration : Size (cm) : Height: 40.3; Diameter of mouth: 14.3; Diameter of belly: 23; Diameter of base: 11.3. Unearthed From : ZLK Collected By : Liaoning provincial museum Date (AD) : early Published : Feng Yongqian 1960, 15-24, fig.7:2; Zhongguo taoci quanji bianji weiyuanhui 1999, Pl.40; Shanghai renmin meishu chubanshe ed. 1986, pl. 47; Liaoningsheng bowuguan 1961, pl. 46.</p>	  <p>Cat. 293</p>
<p>Catalogue No. : Cat. 294 Type : A Body : porcelain Glaze : white Decoration : Size (cm) : Height: 30.7. Unearthed From : Collected By : Seattle Art Museum, Eugene Fuller Memorial Collection Date (AD) : early Published : Mino Yutaka et al. 1973, pl.35.</p>	 <p>Cat. 294</p>
<p>Catalogue No. : Cat. 295 Type : A Body : porcelain Glaze : white Decoration : Size (cm) : Height: 41.2. Unearthed From : Collected By : Nelson Gallery-Atkins Museum, Kansas City Date (AD) : early Published : Mok 1985, pl. 52; Mino Yutaka et al. 1973, pl.38.</p>	 <p>Cat. 295</p>

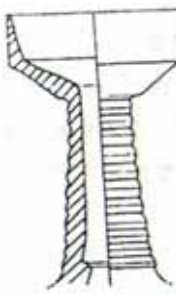
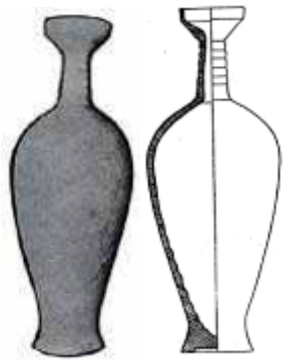



<p>Catalogue No. : Cat. 296 Type : A Body : porcelain Glaze : white Decoration : Green dotted on the shoulder Size (cm) : Height: 43.2. Unearthed From : Collected By : FMM Date (AD) : 959 Published : Zheng Shaozong 1956, 1-26, fig.6:3.</p>	 <p>Cat. 296</p>
<p>Catalogue No. : Cat. 297 Type : A Body : porcelain Glaze : white Decoration : Size (cm) : Height: 45.7. Unearthed From : Collected By : The Metropolitan Museum of Art, New York ,Gift of Mrs. Samuel T. Peters Date (AD) : early Published : Mok 1985, pl.31.</p>	 <p>Cat. 297</p>
<p>Catalogue No. : Cat. 298 Type : A Body : Pinkish earthenware Glaze : green Decoration : Raised lines on the neck and the junction part between shoulder and neck; incised lotus pedals design on the lower belly. Size (cm) : Height: 47.7. Unearthed From : AXZ Collected By : Date (AD) : middle I Published : Beijingshi wenwu yanjiusuo 1992, 17-23, fig.4:5.</p>	 <p>Cat. 298</p>
<p>Catalogue No. : Cat. 299 Type : A Body : Yellowish stoneware Glaze : white Decoration : Size (cm) : Heigh: 42.7. Unearthed From : Collected By : Guan Baocong collection Date (AD) : Published : Lu Jing 2003, pl. 3-236.</p>	 <p>Cat. 299</p>



<p>Catalogue No. : Cat. 300 Type : A Body : Pinkish earthenware Glaze : Green and yellow Decoration : Three Raised lines encircling on the neck Size (cm) : Height: 30.5 Unearthed From : EBD2 Collected By : Date (AD) : early Published : Xiang Chunsong 1984a, 80-90, fig.2:3.</p>	 <p>Cat. 300</p>
<p>Catalogue No. : Cat. 301 Type : A Body : Yellowish stoneware Glaze : white Decoration : Sgraffito peony scroll on the body Size (cm) : Height: 45.6; Diameter of belly: 17.4; Diameter of mouth: 11.4; Diameter of base: 10.4. Unearthed From : YMT7 Collected By : Liaoning provincial museum Date (AD) : 977 Published : Feng Yongqian 1975, 40-48, fig. 4:1; Xu Bingkun & Sun Shoudao ed. 1998, pl. 229; Zhongguo taoqi quanji bianji weiyuanhui 1999, pl. 3.</p>	 <p>Cat. 301</p>
<p>Catalogue No. : Cat. 302 Type : A Body : Yellowish stoneware Glaze : white Decoration : Carved peony spray on the body Size (cm) : Height: 52.9. Unearthed From : Collected By : Date (AD) : Published : Mok 1985, pl.57.</p>	 <p>Cat. 302</p>
<p>Catalogue No. : Cat. 303 Type : A Body : Yellowish stoneware Glaze : white Decoration : Carved peony spray on the body Size (cm) : Height: 50.8. Unearthed From : Collected By : The Metropolitan Museum of Art, New York Date (AD) : Published : Mino Yutaka et al. 1973, pl. 29; Mok 1985, pl. 55.</p>	 <p>Cat. 303</p>



<p>Catalogue No. : Cat. 304 Type : A Body : Yellowish stoneware Glaze : white Decoration : Carved peony spray on the body Size (cm) : Height: 41. Unearthed From : Collected By : Idemitsu Museum of Art,Tokyo Date (AD) : Published : Mok 1985, pl. 56.</p>	 <p>Cat. 304</p>
<p>Catalogue No. : Cat. 305 Type : A Body : Yellowish stoneware Glaze : white Decoration : Ribbed neck Size (cm) : Uncompleted, only left neck and mouth Unearthed From : Tomb at Majiagou, Linyuan county, Liaoning Collected By : Date (AD) : Published : Lü Xueming & Zhu Da 2003, 134-141, fig. 7:10.</p>	 <p>Cat. 305</p>
<p>Catalogue No. : Cat. 306 Type : A Body : Yellowish stoneware Glaze : white Decoration : Ribbed neck Size (cm) : Height: 56.8. Unearthed From : QHM1 Collected By : Date (AD) : 1044 Published : Li Wenxin 1954, 163-202, fig.4:3.</p>	 <p>Cat. 306</p>
<p>Catalogue No. : Cat. 307 Type : A Body : Yellowish stoneware Glaze : white Decoration : Size (cm) : Height: 36.5.. Unearthed From : KL3 Collected By : Date (AD) : middle Published : Wang Jianqun & Chen Xiangwei 1989, 51, fig. 37:3, pl.24:4.</p>	 <p>Cat. 307</p>



<p>Catalogue No. : Cat. 308 Type : A Body : Yellowish stoneware Glaze : white Decoration : Ribbed neck Size (cm) : Height: 55; Diameter of mouth: 12; Diameter of base: 13.5. Unearthed From : a tomb at Yimatu, Beizifu township, Aohan Banner, Inner Mongolia Collected By : Aohan Banner Museum, Inner Mongolia Date (AD) : Published : Shao Guotian ed. 2004, pl. 142-2.</p>	 <p>Cat. 308</p>
<p>Catalogue No. : Cat. 309 Type : A Body : Yellowish stoneware Glaze : white Decoration : Size (cm) : Height: 46.8. Unearthed From : Collected By : British Museum, London (1986 10-12 186) Date (AD) : Published : Watson 1984, pl. 271.</p>	 <p>Cat. 309</p>
<p>Catalogue No. : Cat. 310 Type : A Body : Yellowish stoneware Glaze : white Decoration : Size (cm) : Height: 39.2; Diameter of mouth: 10.3; Diameter of belly: 16.2; Diameter of base: 9.3. Unearthed From : Collected By : Liaoning provincial museum Date (AD) : Published : Liaoningsheng bowuguan 1961, pl. 47.</p>	 <p>Cat. 310</p>
<p>Catalogue No. : Cat. 311 Type : A Body : Yellowish stoneware Glaze : white Decoration : Size (cm) : Height: 33; Diameter of mouth: 10.2; Diameter of base 8. Unearthed From : Collected By : Guan Baocong collection Date (AD) : Published : Lu Jing 2003, pl.4-67.</p>	 <p>Cat. 311</p>

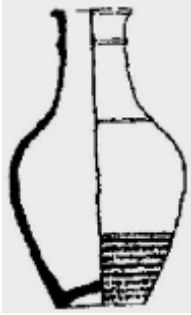

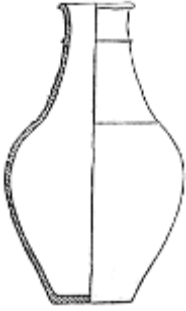
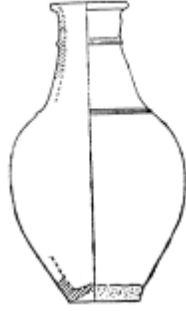
<p>Catalogue No. : Cat. 312 Type : A Body : Pinkish earthenware Glaze : white Decoration : Incised flowering plant through white slip and touches of green glaze Size (cm) : Height: 37.7. Unearthed From : Collected By : Japanese collection Date (AD) : Published : Sugimura Yuzo 1974, pl. 48; Mok 1985, pl.58.</p>	 <p>Cat. 312</p>
<p>Catalogue No. : Cat. 313 Type : A Body : Pinkish earthenware Glaze : white Decoration : Incised flowering plant through white slip and touches of green glaze Size (cm) : Height: 36.2. Unearthed From : Collected By : Tokyo National museum Date (AD) : Published : Sugimura Yuzo 1974, pl. 6.</p>	 <p>Cat. 313</p>
<p>Catalogue No. : Cat. 314 Type : A Body : Pinkish earthenware Glaze : white Decoration : A bow string pattern adorns the neck and a pair of carved peony pattern is on the body. Size (cm) : Height: 52.8; Diameter of mouth: 13.8; Diameter of base: 10. Unearthed From : a tomb at Buhetehada, Bayanerdeng Sumu, Balin Right Banner, Inner Mongolia Collected By : Baling Right Banner Museum, Inner Mongolia Date (AD) : Published : Neimenggu zizhiqu wenhuating & Zhongguo lishi bowuguan 2002, pl. 234; Shanghai bowuguan 2000, pl. 173.</p>	 <p>Cat. 314</p>



<p>Catalogue No. : Cat. 315 Type : A Body : Pinkish earthenware Glaze : green Decoration : Size (cm) : Height; 33.9; Diameter of mouth: 8.6; Diameter of base: 7.6. Unearthed From : Collected By : The palace museum, Beijing Date (AD) : late Published : Zhongguo taoci quanji bianji weiyuanhui 1999, pl. 88.</p>	 <p>Cat. 315</p>
<p>Catalogue No. : Cat. 316 Type : A Body : Pinkish earthenware Glaze : green Decoration : Size (cm) : Height: 31.8; Diameter of mouth 9.9; Diameter of base: 6.5. Unearthed From : Collected By : Guan Baocong collection Date (AD) : late Published : Lu Jing 2003, pl. 4-167.</p>	 <p>Cat. 316</p>
<p>Catalogue No. : Cat. 317 Type : A Body : Pinkish earthenware Glaze : green Decoration : Size (cm) : Height: 35; Diameter of mouth 9.8; Diameter of base: 6.8. Unearthed From : Collected By : Guan Baocong collection Date (AD) : late Published : Lu Jing 2003, pl. 4-168.</p>	 <p>Cat. 317</p>
<p>Catalogue No. : Cat. 318 Type : A Body : Pinkish earthenware Glaze : green Decoration : Size (cm) : Height: 23.5 Unearthed From : Collected By : The Lowe Art Museum University of Miami Date (AD) : late Published : Mino Yutaka et al. 1973, pl. 20.</p>	 <p>Cat. 318</p>

<p>Catalogue No. : Cat. 319 Type : A Body : Pinkish earthenware Glaze : green Decoration : Size (cm) : Height: 31.1; Diameter of mouth 9.4; Diameter of base:7.7. Unearthed From : Collected By : Guan Baocong collection Date (AD) : late Published : Lu Jing 2003, pl. 4-169.</p>	 <p>Cat. 319</p>
<p>Catalogue No. : Cat. 320 Type : A Body : Pinkish earthenware Glaze : green Decoration : Size (cm) : Height: 39; Diameter of mouth 12.5. Unearthed From : a tomb at Dalaming'anla, Meilihe commune, Chifeng city, Inner Mongolia Collected By : Chifeng municipal museum, Inner Mongolia Date (AD) : late Published : Shanghai renmin meishu chubanshe ed. 1986, pl. 7.</p>	 <p>Cat. 320</p>
<p>Catalogue No. : Cat. 321 Type : Pro-type Body : pottery Glaze : Decoration : Size (cm) : Unearthed From : DHG1 Collected By : Date (AD) : early Published : Shao Guotian 1987, 889-904.</p>	 <p>Cat. 321</p>
<p>Catalogue No. : Cat. 322 Type : Pro-type Body : pottery Glaze : Decoration : Size (cm) : Unearthed From : NZLYZ1 Collected By : Date (AD) : early Published : Liaoningsheng wenwu kaogu yanjiusuo et al. 1992, 54-63.</p>	 <p>Cat. 322</p>



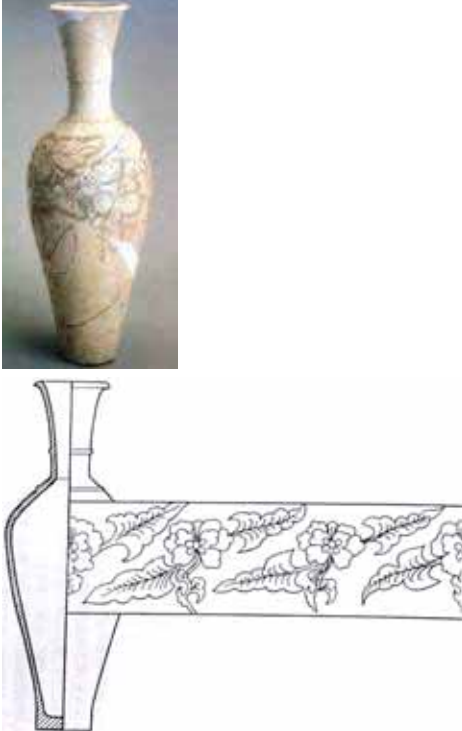

<p>Catalogue No. : Cat. 323 Type : B Body : Pinkish earthenware Glaze : green Decoration : Raised lines on the neck and shoulder Size (cm) : Height: 56. Unearthed From : SZG1 Collected By : Date (AD) : early Published : Shao Guotian 1987, 889-904.</p>	 <p>Cat. 323</p>
<p>Catalogue No. : Cat. 324 Type : B Body : Pinkish earthenware Glaze : brown Decoration : Raised lines on the neck and shoulder Size (cm) : Height: 50. Unearthed From : HLB1 Collected By : Date (AD) : early Published : Li Yufeng 1991, 106-119, fig.3:10.</p>	 <p>Cat. 324</p>
<p>Catalogue No. : Cat. 325 Type : B Body : Pinkish earthenware Glaze : brown Decoration : Raised lines on the neck and shoulder Size (cm) : Height: 50. Unearthed From : Collected By : Guan Baocong collection Date (AD) : early Published : Lu Jing 2003, pl. 3-138.</p>	 <p>Cat. 325</p>
<p>Catalogue No. : Cat. 326 Type : B Body : Pinkish earthenware Glaze : green Decoration : Raised lines on the neck, and applied relief design on the shoulder Size (cm) : Height: 47.3; Diameter of mouth: 12; Diameter of belly: 24.4; Diameter of base: 9.6. Unearthed From : a tomb at Ningcheng, Inner Mongolia Collected By : Liaoning provincial museum Date (AD) : middle II Published : Zhongguo taoci quanji bianji weiyuanhui 1999, pl. 75; Shanghai remin meishu chubanshe ed. 1986, pl. 29.</p>	 <p>Cat. 326</p>





<p>Catalogue No. : Cat. 327 Type : B Body : Pinkish earthenware Glaze : brown Decoration : Raised lines on the neck and shoulder Size (cm) : Height: 53; Diameter of mouth: 13.5. Unearthed From : YMT7 Collected By : Liaoning provincial museum Date (AD) : 977 Published : Zhongguo taoci quanji bianji weiyuanhui 1999, pl. 58; Xu Bingkun & Sun Shoudao ed. 1998, pl. 233; Feng Yongqian 1975, 40-48, fig: 4:2; Shanghei renmin meishu chubanshe ed. 1986, pl. 105.</p>	 <p>Cat. 327</p>
<p>Catalogue No. : Cat. 328 Type : B Body : Pinkish earthenware Glaze : green Decoration : Raised lines on the neck and shoulder Size (cm) : Height: 58.4; Diameter of mouth: 8.5. Unearthed From : CGGZ Collected By : Inner Mongolia cultural relics and archaeology institute Date (AD) : 1018 Published : Zhongguo taoci quanji bianji weiyuanhui 1999, pl. 94; Neimenggu wenwu kaogu yanjiusuo et al. 1993, 53, fig. 32:1.</p>	 <p>Cat. 328</p>
<p>Catalogue No. : Cat. 329 Type : B Body : Pinkish earthenware Glaze : green Decoration : Raised lines on the neck and shoulder; applied relief on the shoulder. Size (cm) : Height: 62.5 Unearthed From : KL3 Collected By : Date (AD) : middle II Published : Wang Jianqun & Chen Xiangwei 1989, 51, fig. 37:1, pl.24:1.</p>	 <p>Cat. 329</p>

<p>Catalogue No. : Cat. 330 Type : B Body : Pinkish earthenware Glaze : green Decoration : Raised lines on the neck and shoulder Size (cm) : Height: 52; Diameter of mouth: 11.3; Diameter of base: 10.6. Unearthed From : a tomb at Jinchanggouliang township, Aohan Banner, Inner Mongolia Collected By : Aohan Banner Museum, Inner Mongolia Date (AD) : middle II Published : Shao Guotian ed. 2004, pl. 141.</p>	 <p>Cat. 330</p>
<p>Catalogue No. : Cat. 331 Type : B Body : Pinkish earthenware Glaze : white Decoration : Raised lines on the neck and shoulder Size (cm) : Height: 48.4; Diameter of mouth: 12.1; Diameter of belly: 21; Diameter of base; 9.7. Unearthed From : QHM4 Collected By : Liaoning provincial museum Date (AD) : middle II- middle III Published : Li Wenxin 1954, 163-202, fig. 23:2; Shanghai renmin meishu chubanshe ed. 1986, pl. 63; Liaoningsheng bowuguan 1961, pl. 43.</p>	 <p>Cat. 331</p>
<p>Catalogue No. : Cat. 332 Type : B Body : Pinkish earthenware Glaze : white Decoration : Incised peony design Size (cm) : Height: 56; Diameter of mouth: 12. Unearthed From : YMT2 Collected By : Liaoning Tieling qunzhongyishuguan wenwuzu Date (AD) : late Published : Shanghai renmin meishu chubanshe ed. 1986, pl.113. Feng Yongqian 1994a, 163-90, fig.3:2.</p>	 <p>Cat. 332</p>

<p>Catalogue No. : Cat. 333 Type : B Body : Pinkish earthenware Glaze : green Decoration : Incised peony design on the body Size (cm) : Height: 38; Diameter of mouth; 10; Diameter of base: 8. Unearthed From : a tomb at Qiaotou Township, Wengniute Banner, Inner Mongolia Collected By : Wengniute Banner Museum, Inner Mongolia Date (AD) : late Published : Neimenggu zizhiqu wenhuating & Zhongguo lishi bowuguan 2002, pl. 237.</p>	 <p>Cat. 333</p>
<p>Catalogue No. : Cat. 334 Type : B Body : Pinkish earthenware Glaze : white Decoration : Size (cm) : Height: 29.6. Unearthed From : Collected By : Japanese collection Date (AD) : Published : Sugimura Yuzo 1974, pl.46.</p>	 <p>Cat. 334</p>
<p>Catalogue No. : Cat. 335 Type : B Body : Pinkish earthenware Glaze : yellow Decoration : Size (cm) : Height: 31; Diameter of mouth: 8.8, Diameter of base: 4.7. Unearthed From : a tomb at Erguanyingzi, Beizifu Township, Aohan Banner, Inner Mongolia Collected By : Aohan Banner Museum, Inner Mongolia Date (AD) : late Published : Shao Guotian ed. 2004, pl. 142-1.</p>	 <p>Cat. 335</p>
<p>Catalogue No. : Cat. 336 Type : B Body : Pinkish earthenware Glaze : yellow Decoration : Impressed flowers Size (cm) : Height: 31; Diameter of mouth: 7.5; Diameter of base: 6.2. Unearthed From : Collected By : Guan Baocong collection Date (AD) : Published : Lu Jing 2003, pl. 4-144</p>	 <p>Cat. 336</p>



<p>Catalogue No. : Cat. 337 Type : B Body : Pinkish earthenware Glaze : yellow Decoration : Size (cm) : Height: 36.2; Diameter of mouth: 9; Diameter of base: 7.3. Unearthed From : Collected By : Guan Baocong collection Date (AD) : Published : Lu Jing 2003, pl. 4-143</p>	 <p>Cat. 337</p>
<p>Catalogue No. : Cat. 338 Type : B Body : Pinkish earthenware Glaze : green Decoration : Size (cm) : Height: 34.9. Unearthed From : BTYZ Collected By : Liaoning provincial museum Date (AD) : late Published : Feng Yongqian 1960, 15-24, fig.9:1; Shanghai renmin meishu chubanshe ed. 1986, pl. 104; liaoningsheng bowuguan1961, pl. 44.</p>	 <p>Cat. 338</p>
<p>Catalogue No. : Cat. 339 Type : B Body : Pinkish earthenware Glaze : yellow Decoration : Size (cm) : Height: 31.5. Unearthed From : BL3 Collected By : Date (AD) : late Published : Wu Jiachang 1986, 32-51, fig.15:2.</p>	 <p>Cat. 339</p>



<p>Catalogue No. : Cat. 340 Type : B Body : Pinkish earthenware Glaze : green Decoration : Size (cm) : Height: 26; Diameter of mouth: 6; Diameter of base: 7.6. Unearthed From : YWG Collected By : Date (AD) : late Published : Ma Qingpeng & Zhao Zhihou 1997, 47-49, fig.2:5.</p>	 <p>Cat. 340</p>
<p>Catalogue No. : Cat. 341 Type : B Body : Pinkish earthenware Glaze : yellow Decoration : Size (cm) : Height: 35.6. Unearthed From : Collected By : Japanese collection Date (AD) : Published : Sugimura Yuzo 1974, pl.45.</p>	 <p>Cat. 341</p>
<p>Catalogue No. : Cat. 342 Type : B Body : Pinkish earthenware Glaze : yellow Decoration : Incised peony designs Size (cm) : Height: 36.3; Diameter of belly: 14.2; Diameter of mouth: 10.3; Diameter of base: 8.2. Unearthed From : Collected By : Liaoning provincial museum Date (AD) : Published : Zhongguo taoci quanji bianji weiyuanhui 1999, pl. 65; Shanhai renmin meishu chubanshe ed. 1986, pl. 22; Liaoningsheng bowuguan 1961, pl. 7.</p>	 <p>Cat. 342</p>
<p>Catalogue No. : Cat. 343 Type : B Body : Pinkish earthenware Glaze : yellow Decoration : Incised peony designs Size (cm) : Height: 36.2. Unearthed From : Collected By : Japanese collection Date (AD) : Published : Sugimura Yuzo 1974, pl.8.</p>	 <p>Cat. 343</p>



<p>Catalogue No. : Cat. 344 Type : B Body : Pinkish earthenware Glaze : yellow Decoration : Size (cm) : Height: 36.4; Diameter of mouth: 12; Diameter of belly: 13.2; Diameter of base: 7.5. Unearthed From : Collected By : Liaoning provincial museum Date (AD) : late Published : Shanghai renmin meishu chubanshe ed. 1986, pl. 37; Liaoningsheng bowuguan 1961, pl. 45.</p>	 <p>Cat. 344</p>
<p>Catalogue No. : Cat. 345 Type : B Body : Pinkish earthenware Glaze : yellow Decoration : Size (cm) : Height: 32.7; Diameter of mouth: 9.5; Diameter of base: 6.3. Unearthed From : Collected By : Guan Baocong collection Date (AD) : Published : Lu Jing 2003, pl. 4-142</p>	 <p>Cat. 345</p>
<p>Catalogue No. : Cat. 346 Type : B Body : Pinkish earthenware Glaze : green Decoration : Size (cm) : Height: 33. Unearthed From : Collected By : Center of Asian Art and Culture, Avery Brundage Collection ,San Francisco, California Date (AD) : Published : Mino Yutaka et al. 1973, pl. 18.</p>	 <p>Cat. 346</p>
<p>Catalogue No. : Cat. 347 Type : B Body : Pinkish earthenware Glaze : green Decoration : Size (cm) : Height: 23.1. Unearthed From : Collected By : Center of Asian Art and Culture, Avery Brundage Collection ,San Francisco, California Date (AD) : late Published : Mino Yutaka et al, 1973, pl. 19; Mok 1985, pl. 63.</p>	 <p>Cat. 347</p>



<p>Catalogue No. : Cat. 348 Type : B Body : Pinkish earthenware Glaze : white Decoration : Size (cm) : Height: 28.6; Diameter of mouth: 6.5; Diameter of base: 7. Unearthed From : Collected By : Guan Baocong collection Date (AD) : Published : Lu Jing 2003, pl. 4-68.</p>	 <p>Cat. 348</p>
---	--

3.7 PHOENIX-HEAD VASE



<p>Catalogue No. : Cat. 349 Type : A Body : Poecelain Glaze : white Decoration : Size (cm) : Height: 45.9. Unearthed From : Collected By : Japanese collection Date (AD) : early Published by : Sugimura Yuzo 1974, pl.49.</p>	 <p>Cat. 349</p>
<p>Catalogue No. : Cat. 350 Type : A Body : porcelain Glaze : white Decoration : Size (cm) : Height: 46.5. Unearthed From : Collected By : The library of Gaotang county, Shandong province Date (AD) : early Published by : Lu jing 2003, pl. 3-272.</p>	 <p>Cat. 350</p>





<p>Catalogue No. : Cat. 351 Type : A Body : Pinkish earthenware Glaze : Green Decoration : small petals in applied relief decorated on the shoulder and carved overlapping lotus petals on the lower part of the belly Size (cm) : Height: 45.5-46. Unearthed From : QCH Collected By : Liaoning provincial museum Date (AD) : middle Published by : Jin Fengyi 1980, 17-29, fig.6.</p>	 <p>Cat. 351</p>
<p>Catalogue No. : Cat. 352 Type : A Body : Pinkish earthenware Glaze : Green Decoration : small petals in applied relief decorated on the shoulder Size (cm) : Height: 41.3; Diameter of mouth: 9; Diameter of belly: 16.3. Unearthed From : SQ1 Collected By : Liaoning provincial museum Date (AD) : middle Published by : Xu Yulin 1977, 44-51, fig.23:1; Shanhai renmin meishu chubanshe ed. 1986, pl. 21.</p>	 <p>Cat. 352</p>
<p>Catalogue No. : Cat. 353 Type : A Body : Pinkish earthenware Glaze : green Decoration : Size (cm) : Height: 52.5; Diameter of mouth: 11.6; Diameter of belly: 17.5; Diameter of base: 10.4.. Unearthed From : QHM2 Collected By : Liaoning provincial museum Date (AD) : 1057 Published by : Li Wenxin 1954,163-202, fig.10:4; Shanhai renmin meishu chubanshe ed. 1986, pl. 43; Liaoningsheng bowuguan 1961, pl. 41.</p>	 <p>Cat. 353</p>

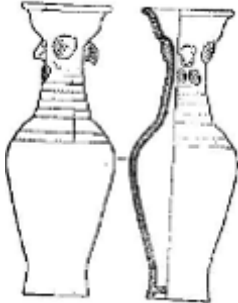



<p>Catalogue No. : Cat. 354 Type : A Body : Pinkish earthenware Glaze : green Decoration : Incised peony design on the body Size (cm) : Height: 37; Diameter of mouth: 10; Diameter of base: 6.9. Unearthed From : a tomb at Tuquan county, Xing'an League, Inner Mongolia Collected By : Inner Mongolia autonomous region museum Date (AD) : Published by : Zhongguo taoci quanji bianji weiyuanhui 1999, pl.83; Zhonghua shiji tan & Neimenggu bowuguan 2004, pl. 217.</p>	 <p>Cat. 354</p>
<p>Catalogue No. : Cat. 355 Type : A Body : Pinkish earthenware Glaze : yellow Decoration : Size (cm) : Height: 48.1; Diameter of mouth: 12.5; Diameter of base : 8.1. Unearthed From : The wall city of Qingzhou, Suoboriga Township, Balin Right Banner Collected By : Balin Right Banner Museum, Inner Mongolia Date (AD) : Published by : Neimenggu zizhiqiu wenhuating & Zhongguo lishi bowuguan 2002, pl. 239; Shen Hsueh-man 2006, pl. 106.</p>	 <p>Cat. 355</p>
<p>Catalogue No. : Cat. 356 Type : A Body : Pinkish earthenware Glaze : green Decoration : Incised peony design on the body Size (cm) : Height: 38.2. Unearthed From : Collected By : Tokyo national museum Date (AD) : Published by : Mino Yutaka et al. 1973, pl.49; Sugimura Yuzo 1974, pl.9.</p>	 <p>Cat. 356</p>

<p>Catalogue No. : Cat. 357 Type : A Body : Pinkish earthenware Glaze : yellow Decoration : Size (cm) : Height: 36.8; Diameter of belly: 13; Diameter of mouth: 9.8; Diameter of base: 7.6. Unearthed From : Collected By : Liaoning provincial museum Date (AD) : Published by : Zhongguo taoci quanji bianji weiyuanhui 1999, pl.66; Liaoningsheng bowuguan 1961, pl. 6.</p>	 <p>Cat. 357</p>
<p>Catalogue No. : Cat. 358 Type : A Body : Pinkish earthenware Glaze : yellow Decoration : Size (cm) : Height: 37.1; Diameter of belly: 13; Diameter of mouth: 9.6. Unearthed From : Collected By : Liaoning provincial museum Date (AD) : Published by : Shanghai renmin meishu chubanshe ed. 1986, pl. 70.</p>	 <p>Cat. 358</p>
<p>Catalogue No. : Cat. 359 Type : A Body : Pinkish earthenware Glaze : green Decoration : Size (cm) : Uncompleted, only left the part above neck Unearthed From : CKTDS4 Collected By : Chifeng municipal museum, Inner Mongolia Date (AD) : late Published by : Liu Bing et al. 1998, 26-34,38, fig.11:4.</p>	 <p>Cat. 359</p>

<p>Catalogue No. : Cat. 360 Type : A Body : Pinkish earthenware Glaze : green Decoration : Size (cm) : Height: 39; Diameter of mouth: 8.8; Diameter of base: 8.5. Unearthed From : a tomb at Dongdashaan, Kelidai Township, Aohan Banner, Inner Mongolia Collected By : Aohan Banner Museum, Inner Mongolia Date (AD) : late Published by : Shao Guotian ed. 2004, 134.</p>	 <p>Cat. 360</p>
<p>Catalogue No. : Cat. 360Cat. 361 Type : A Body : Pinkish earthenware Glaze : yellow Decoration : Size (cm) : Height: 46.6; Diameter of mouth: 13.1; Diameter of base: 9.3. Unearthed From : a tomb at Jiefangtun, Sijizi Township, Aohan Banner, Inner Mongolia Collected By : Aohan Banner Museum, Inner Mongolia Date (AD) : late Published by : Shao Guotian ed. 2004, 134.</p>	 <p>Cat. 361</p>
<p>Catalogue No. : Cat. 362 Type : A Body : Pinkish earthenware Glaze : green Decoration : Size (cm) : Height: 50. Unearthed From : XXZ Collected By : Date (AD) : 1089 Published by : Yan Yu 1960, 34-5, fig.1:4.</p>	 <p>Cat. 362</p>

<p>Catalogue No. : Cat. 363 Type : A Body : Pinkish earthenware Glaze : yellow Decoration : Size (cm) : Height: 33. Unearthed From : XLZZ2 Collected By : Date (AD) : late Published by : Li Yiyou 1961, 44-9, fig.5.</p>	 <p>Cat. 363</p>
<p>Catalogue No. : Cat. 364 Type : A Body : Pinkish earthenware Glaze : yellow Decoration : Size (cm) : Height: 32.8. Unearthed From : FZZ Collected By : Date (AD) : late Published by : Ta La & Yiyou 1984, 75-9, fig.2.</p>	 <p>Cat. 364</p>
<p>Catalogue No. : Cat. 365 Type : A Body : Pinkish earthenware Glaze : yellow Decoration : Size (cm) : Height: 32. Unearthed From : XPJG Collected By : Date (AD) : late Published by : Zhang Hanying & Bai Guang 1993, 957-8, fig.1:1.</p>	 <p>Cat. 365</p>
<p>Catalogue No. : Cat. 366 Type : A Body : Pinkish earthenware Glaze : green Decoration : Size (cm) : Height 35.4. Unearthed From : Collected By : Japanese collection Date (AD) : late Published by : Sugimura Yuzo 1974, pl.50</p>	 <p>Cat. 366</p>

<p>Catalogue No. : Cat. 367 Type : A Body : Pinkish earthenware Glaze : green Decoration : Size (cm) : Height 37.5; Diameter of mouth: 10.1; Diameter of belly: 13.4; Diameter of base: 7.5.. Unearthed From : Collected By : Liaoning provincial museum Date (AD) : late Published by : Liaoningsheng bowuguan 1961, pl. 42.</p>	 <p>Cat. 367</p>
<p>Catalogue No. : Cat. 368 Type : A Body : Pinkish earthenware Glaze : green Decoration : Size (cm) : Height: 32. Unearthed From : Collected By : Guan Baocong collection Date (AD) : late Published by : Lu Jing 2003, pl. 3-285.</p>	 <p>Cat. 368</p>
<p>Catalogue No. : Cat. 369 Type : B Body : Pinkish earthenware Glaze : white Decoration : sgraffito peony scroll covered with green glaze Size (cm) : Height: 41.7. Unearthed From : Collected By : The Museum Yamato Bunkakan, Nara Date (AD) : middle Published by : Sugimura Yuzo 1974, pl.7.</p>	 <p>Cat. 369</p>
<p>Catalogue No. : Cat. 370 Type : B Body : Pinkish earthenware Glaze : white Decoration : sgraffito peony scroll covered with green glaze Size (cm) : Height: 42.8. Unearthed From : Collected By : Royal Ontario Museum, Toronto Date (AD) : Published by : Sugimura Yuzo 1974, pl.47.</p>	 <p>Cat. 370</p>

<p>Catalogue No. : Cat. 371 Type : Body : Buff stoneware Glaze : green Decoration : Melon-shaped body with nine lobes Size (cm) : Height: 21.6; diameter of belly: 12.7. Unearthed From : Collected By : Royal Ontario Museum, Toronto Date (AD) : Tang Published by : Mino Yutaka et al. 1973, pl. 53.</p>	 <p>Cat. 371</p>
<p>Catalogue No. : Cat. 372 Type : Body : Pinkish earthenware Glaze : Three-colore lead glaze Decoration : Applied relief design Size (cm) : Height: 31.5. Unearthed From : Collected By : Date (AD) : 8th century Published by : Mok 1985, pl. 43.</p>	 <p>Cat. 372</p>
<p>Catalogue No. : Cat. 373 Type : Body : porcelain Glaze : white Decoration : Size (cm) : Height: 37.5. Unearthed From : Collected By : Idemitsu Bijutsukan, Tokyo Date (AD) : Tang Published by : Watson 1984, pl. 287</p>	 <p>Cat. 373</p>
<p>Catalogue No. : Cat. 374 Type : Body : porcelain Glaze : white Decoration : Size (cm) : Height: 42.2. Unearthed From : Collected By : British Museum, London Date (AD) : Tang Published by : Mok 1985, pl.44.</p>	 <p>Cat. 374</p>

Catalogue No. : Cat. 375

Type :

Body : porcelain

Glaze : white

Decoration : With fully modelled bird's head, the sides bearing a dense peony scroll between zones of carved petals.

Size (cm) : Height: 39.4.

Unearthed From :

Collected By : British Museum, London

Date (AD) : Tang

Published by : Watson 1984, pl. 273.



Cat. 375

Catalogue No. : Cat. 376

Decoration : Mural painting

Unearthed From : a tomb at Zhaoduba, Chaoyang, Liaoning

Date (AD) : late

Published by : Chaoyangshi bowuguan & Chaoyangshi longchengqu bowuguan 2004, 64-6.



Cat. 376

Catalogue No. : Cat. 377

Type :

Body : silver

Glaze :

Decoration :

Size (cm) : Height: 25.

Unearthed From : LJYZ1

Collected By : Inner Mongolia autonomous region museum





Date (AD) : Tang





Published by : Zhang Jingming 2005, pl.69.



Cat. 377



3.8 SPOUTED EWER





<p>Catalogue No. : Cat. 378 Type : Aa Body : Buff stoneware Glaze : white Decoration : Size (cm) : Height: 15.2. Unearthed From : HLB1 Collected By : Date (AD) : early Published : Li Yufeng 1991, 106-19, fig.3:7.</p>	 <p>Cat. 378</p>
<p>Catalogue No. : Cat. 379 Type : Aa Body : Buff stoneware Glaze : green Decoration : Size (cm) : Height: 19.8. Unearthed From : DQTL3 Collected By : Date (AD) : early Published : Meng Jianren & Piao Chunyue 1997, 651-67, fig.10:2.</p>	 <p>Cat. 379</p>
<p>Catalogue No. : Cat. 380 Type : Aa Body : Buff stoneware Glaze : green Decoration : Dragon head shaped spout, Applied relief designs Size (cm) : Height: 11. Unearthed From : a tomb at Zhengning county, Gansu province Collected By : Zhenning prefectural Museum, Gansu province Date (AD) : early Published : Lu Jing 2003, pl. 3-175</p>	 <p>Cat. 380</p>
<p>Catalogue No. : Cat. 381 Type : Aa Body : Buff stoneware Glaze : green Decoration : Applied relief designs Size (cm) : Height: 16.1. Unearthed From : Collected By : Mr. and Mrs Myron S. Falk, Jr. New York Date (AD) : early Published : Mino Yutaka et al 1973, pl. 56.</p>	 <p>Cat. 381</p>

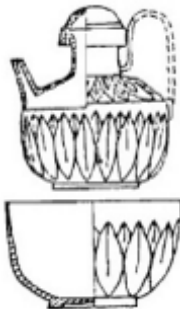
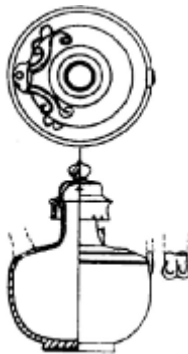

<p>Catalogue No. : Cat. 382 Type : Aa Body : Pinkish earthenware Glaze : yellow Decoration : Applied relief designs Size (cm) : Height: 17.8; Diameter of mouth: 3.4; Diameter of base: 8.2. Unearthed From : Collected By : Liaoning provincial museum Date (AD) : early Published : Zhongguo taoci quanji bianji weiyuanhui ed. 1999, pl.70</p>	 <p>Cat. 382</p>
<p>Catalogue No. : Cat. 383 Type : Aa Body : Buff stoneware Glaze : yellow Decoration : Dragon head shaped spout, Impressed eye-like ornaments and wave patterns Size (cm) : Height: 16.5. Unearthed From : Collected By : Formerly Frederick M. Mayer Co. Date (AD) : early Published : Mok 1985, pl. 141; Watson 1984, pl. 278.</p>	 <p>Cat. 383</p>
<p>Catalogue No. : Cat. 384 Type : Aa Body : Buff stoneware Glaze : yellow Decoration : six-lobed body decorated with impressed wave design Size (cm) : Height: 16.8 Unearthed From : Collected By : Indianapolis Museum of Art, Gift of Warden McKee Wilson Date (AD) : early Published : Mino Yutaka et al. 1973, pl. 55.</p>	 <p>Cat. 384</p>
<p>Catalogue No. : Cat. 385 Type : Aa Body : Pinkish earthenware Glaze : White glaze with green pigment Decoration : Dragon head shaped spout, carved lotus-petals lower body Size (cm) : Height: 17. Unearthed From : BYD Collected By : Date (AD) : early Published : Yuan Haibo 1985, 958-59, fig.2:3.</p>	 <p>Cat. 385</p>

<p>Catalogue No. : Cat. 386 Type : Aa Body : Buff stoneware Glaze : green Decoration : Dragon head shaped spout, Size (cm) : Height: 14. Unearthed From : Collected By : Tokyo national museum Date (AD) : early Published : Lu Jing 2003, pl. 3-157.</p>	 <p>Cat. 386</p>
<p>Catalogue No. : Cat. 387 Type : Aa Body : Porcelainous stoneware Glaze : white Decoration : Size (cm) : Height: 21.5. Unearthed From : FMM Collected By : Date (AD) : 959 Published : Mok 1985, pl. 78; Watson 1984, pl. 289. Zheng Shaozong 1956, 1-26, fig.7:1(left).</p>	 <p>Cat. 387</p>
<p>Catalogue No. : Cat. 388 Type : Aa Body : Porcelainous stoneware Glaze : white Decoration : Size (cm) : Height: 20.5 Unearthed From : ZLK Collected By : Liaoning provincial museum Date (AD) : early Published : Feng Yongqian 1960, 15-24, fig.7:5.</p>	 <p>Cat. 388</p>
<p>Catalogue No. : Cat. 389 Type : Aa Body : Porcelainous stoneware Glaze : green Decoration : Size (cm) : Height: 15; Diameter of mouth: 4.3; Diameter of base: 8.4. Unearthed From : Collected By : Aohan Banner Museum, Inner Mongolia Date (AD) : early Published : Shao Guotian ed. 2004, pl. 136.</p>	 <p>Cat. 389</p>



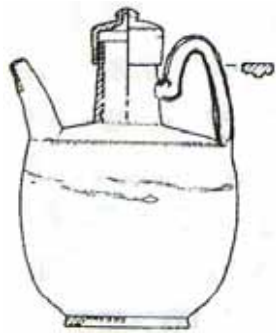

<p>Catalogue No. : Cat. 390 Type : Aa Body : Porcelainous stoneware Glaze : white Decoration : Size (cm) : Height: 20.5 Unearthed From : ZLK Collected By : Liaoning provincial museum Date (AD) : early Published : Feng Yongqian 1960, 15-24, fig.7:5.</p>	 <p>Cat. 390</p>
<p>Catalogue No. : Cat. 391 Type : Aa Body : Porcelainous stoneware Glaze : white Decoration : Under the handle there is an applied relief plum blossom on the body. Size (cm) : Height: 17.4; Diameter of mouth: 4; Diameter of base: 7.8. Unearthed From : Collected By : Aohan Banner Museum, Inner Mongolia Date (AD) : early Published : Shao Guotian ed. 2004, pl. 129-1.</p>	 <p>Cat. 391</p>
<p>Catalogue No. : Cat. 392 Type : Aa Body : Porcelainous stoneware Glaze : white Decoration : Size (cm) : Height: 23. Unearthed From : Collected By : Guan Baocong collection Date (AD) : early Published : Lu Jing 2003, pl. 3-153.</p>	 <p>Cat. 392</p>
<p>Catalogue No. : Cat. 393 Type : Aa Body : Buff stoneware Glaze : white Decoration : Carved lotus petals designs on the body. Size (cm) : Height: 17.2. Unearthed From : BL4 Collected By : Date (AD) : middle Published : Wu Jiachang 1986, 32-51, fig. 21:4.</p>	 <p>Cat. 393</p>





<p>Catalogue No. : Cat. 394 Type : Aa Body : Buff stoneware Glaze : white Decoration : Carved lotus petals designs on the body. Size (cm) : Height: 18. Unearthed From : Collected By : Guan Baocong collection Date (AD) : middle Published : Lu Jing 2003, pl. 3-166</p>	 <p>Cat. 394</p>
<p>Catalogue No. : Cat. 395 Type : Aa Body : Buff stoneware Glaze : white Decoration : Carved lotus petals designs on the body. Size (cm) : Height: 23.4; Diameter of mouth: 4; Diameter of base: 9.7. Unearthed From : a tomb at Laopogou, Linjiadi Township. Aohan Banner, Inner Mongolia Collected By : Aohan Banner Museum, Inner Mongolia Date (AD) : middle Published : Shao Guotian ed. 2004, pl. 132.</p>	 <p>Cat. 395</p>
<p>Catalogue No. : Cat. 396 Type : Aa Body : porcelain Glaze : white Decoration : Carved overlapping lotus petals relief on the body and shoulder. Size (cm) : Height: 19. Unearthed From : SJG1 Collected By : Date (AD) : 1002 Published : Deng Baoxue et al. 1983, 30-38, fig.2:2.</p>	 <p>Cat. 396</p>
<p>Catalogue No. : Cat. 397 Type : Aa Body : Pinkish earthenware Glaze : green Decoration : Incised rolling floral designs on the shoulder Size (cm) : Height: 16.4(with cover 20.6); Diameter of mouth: 4.7; Diameter of base: 15.6. Unearthed From : YMT22 Collected By : Date (AD) : middle Published : Xu Zhiguo & Wei Chunguang 2000, 48-51, fig.3:3.</p>	 <p>Cat. 397</p>





<p>Catalogue No. : Cat. 398 Type : Aa Body : porcelain Glaze : white Decoration : Carved overlapping lotus petals relief on the body and shoulder. Size (cm) : Height: 20.7; Diameter of mouth: 3.8; Diameter of base: 13.5. Unearthed From : BL1 Collected By : Liaoning Provincial Museum Date (AD) : middle Published : Wu Jiachang 1986, 32-51, fig. 4:3; Zhongguo taoci quanji bianji weiyuanhui 1999, pl.32.</p>	 <p>Cat. 398</p>
<p>Catalogue No. : Cat. 399 Type : Aa Body : Pinkish earthenware Glaze : green Decoration : decorated with small petals in applied relief Size (cm) : Height: 21. Unearthed From : QCH Collected By : Liaoning Provincial Museum Date (AD) : 1004 Published : Jin Fengyi 1980, 17-29, fig.9.</p>	 <p>Cat. 399</p>
<p>Catalogue No. : Cat. 400 Type : Aa Body : porcelain Glaze : white Decoration : Carved overlapping lotus petals relief on the body and shoulder. Size (cm) : Height: 22. Unearthed From : SQ1 Collected By : Liaoning Provincial Museum Date (AD) : middle Published : Xu Yulin 1977, 44-51, fig.22:2.</p>	 <p>Cat. 400</p>
<p>Catalogue No. : Cat. 401 Type : Aa Body : porcelain Glaze : white Decoration : Carved overlapping lotus petals relief on the body and shoulder. Size (cm) : Height: 23.1; Diameter of mouth: 4.8. Unearthed From : A tomb at Shuiquan, Beipiao county, Liaoning province Collected By : Liaoning Provincial museum Date (AD) : middle Published : Shanghai renmin meishu chubanshe ed. 1986, pl. 150.</p>	 <p>Cat. 401</p>

<p>Catalogue No. : Cat. 402 Type : Aa Body : porcelain Glaze : white Decoration : Carved overlapping lotus petals relief on the body and shoulder. Size (cm) : Height: 20.5; Diameter of mouth: 4. Unearthed From : Collected By : Liaoning tieling qunzhongyishuguan wenwuzu Date (AD) : Published : Shanghai renmin meishu chubanshe ed. 1986, pl.107;</p>	 <p>Cat. 402</p>
<p>Catalogue No. : Cat. 403 Type : Aa Body : Buff stoneware Glaze : white Decoration : Size (cm) : Height: 23.5 Unearthed From : Tomb at Chaoyanggou, Zhangwu, Liaoning province Collected By : Relics office of Zhangwu city, Liaoning province Date (AD) : middle Published : Li Yufeng et al. 2003, 83-111, fig. 32:3.</p>	 <p>Cat. 403</p>
<p>Catalogue No. : Cat. 404 Type : Aa Body : Pinkish earthenware Glaze : green Decoration : With a domed and knobbed lid. A small monkey applied on the spout. Size (cm) : Height: 22; Diameter of mouth: 4.5; Diameter of base: 8. Unearthed From : Collected By : Aohan Banner Museum Date (AD) : middle Published : Shao Guotian ed. 2004, pl. 131.</p>	 <p>Cat. 404</p>



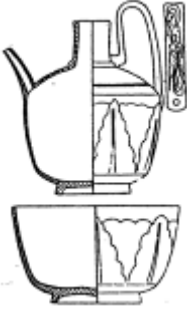

<p>Catalogue No. : Cat. 405 Type : Aa Body : Porcelain Glaze : white Decoration : Carved overlapping lotus petals on the body. Size (cm) : Height: 19.5. Unearthed From : SSG4 Collected By : Date (AD) : middle Published : Xiang Chunsong 1981b, 56-63, fig.5:1.</p>	 <p>Cat. 405</p>
<p>Catalogue No. : Cat. 406 Type : Aa Body : Porcelain Glaze : white Decoration : Carved overlapping lotus petals on the body. Size (cm) : Height: 23.4; diameter of mouth: 4.4, Diameter of belly: 15.7; Diameter of base: 9.3. Unearthed From : A tomb at Baixintun, Keyouqian Banner, Inner Mongolia Collected By : Inner Mongolia Autonomous Region Museum Date (AD) : middle Published : Zhongguo taoci quanji bianji weiyuanhui 1999, pl. 31.</p>	 <p>Cat. 406</p>
<p>Catalogue No. : Cat. 407 Type : Aa Body : Porcelain Glaze : white Decoration : Carved overlapping lotus petals on the body. Incised "Guan" inscription on the exterior bottom Size (cm) : Height: 22.5; diameter of mouth: 4.8, Diameter of base: 8.6 Unearthed From : a tomb at Yimatu, Beizifu township, Aohan Banner, Inner Mongolia Collected By : Aohan Banner Museum Date (AD) : middle Published : Shao Guotian ed. 2004, pl. 125; Neimenggu zizhiqu wenhuating & Zhongguo lishi bowuguan 2002, pl. 241; Shen Hsueh-man et al. 2006, pl. 107a.</p>	 <p>Cat. 407</p>

<p>Catalogue No. : Cat. 408 Type : Aa Body : stoneware Glaze : white Decoration : Carved overlapping lotus petals on the body. Size (cm) : Height: 17.8; diameter of mouth: 4.8, Diameter of base: 12 Unearthed From : Zuozhangzi Village, Wanyuandian Township, Lingyuan County, Liaoning Collected By : The palace museum, Peking Date (AD) : middle Published : Zhongguo taoci quanji bianji weiyuanhui 1999, pl. 14.</p>	 <p>Cat. 408</p>
<p>Catalogue No. : Cat. 409 Type : Aa Body : Pinkish earthenware Glaze : yellow Decoration : Size (cm) : Height: 17.7. Unearthed From : GZX Collected By : Date (AD) : 1027 Published : Zhu Zifang & Xu Ji 1983, 168-95.</p>	 <p>Cat. 409</p>
<p>Catalogue No. : Cat. 410 Type : Aa Body : Pinkish earthenware Glaze : yellow Decoration : Size (cm) : Height: 16.2; Diameter of mouth: 3.7; Diameter of base: 7.1. Unearthed From : A tomb at Wuqintulu village, Zhangjiayingzi Township, Jianping county, Liaoning Province Collected By : Liaoning Provincial Museum Date (AD) : middle Published : Shanhai renmin meishu chubanshe ed. 1986, pl.33; Liaoningsheng bowuguan 1961, pl. 36; Feng Yongqian 1960, 15-24, fig.2:2.</p>	 <p>Cat. 410</p>
<p>Catalogue No. : Cat. 411 Type : Aa Body : Pinkish earthenware Glaze : yellow Decoration : Size (cm) : Height: 18.5 Unearthed From : Collected By : Tokyo National museum Date (AD) : middle Published : Lu Jing 2003, pl. 3-164.</p>	 <p>Cat. 411</p>

<p>Catalogue No. : Cat. 412 Type : Aa Body : Pinkish earthenware Glaze : white Decoration : Dragon head shaped spout, incised designs on the shoulder Size (cm) : Height: 21. Unearthed From : Collected By : Chinese private collection Date (AD) : middle Published : Lu Jing 2003, pl 3-167.</p>	 <p>Cat. 412</p>
<p>Catalogue No. : Cat. 413 Type : Aa Body : Pinkish earthenware Glaze : white Decoration : Incised designs on the shoulder Size (cm) : Height: 19.2. Unearthed From : Collected By : Chinese private collection Date (AD) : middle Published : Lu Jing 2003, pl 3-162.</p>	 <p>Cat. 413</p>
<p>Catalogue No. : Cat. 414 Type : Aa Body : Pinkish earthenware Glaze : green Decoration : decorated with small petals in applied relief Size (cm) : Height: 22. Unearthed From : Collected By : Guan Baocong collection Date (AD) : middle Published : unpublished</p>	 <p>Cat. 414</p>
<p>Catalogue No. : Cat. 415 Type : Aa Body : Pinkish earthenware Glaze : Yellow Decoration : Size (cm) : Height: 18.8; Diameter of mouth: 3.3. Unearthed From : JFYZ Collected By : Chifeng Municipal museum, Inner Mongolia Date (AD) : late Published : Xiang Chunsong 1979, 330-34, fig.3:8; Shanghai renmin meishu chubanshe ed. 1986, pl.141.</p>	 <p>Cat. 415</p>

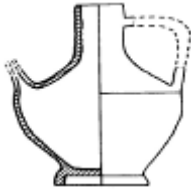
<p>Catalogue No. : Cat. 416 Type : Aa Body : porcelain Glaze : white Decoration : Carved Plantain leaves design on the body. Size (cm) : Height: 20.5. Unearthed From : YMT2 Collected By : Date (AD) : late Published : Feng Yongqian 1994a, 163-90, fig.2:1,2.</p>	 <p>Cat. 416</p>
<p>Catalogue No. : Cat. 417 Type : Aa Body : porcelain Glaze : white Decoration : Carved Plantain leaves design on the body. Size (cm) : Height: 22.5; Diameter of mouth: 4.. Unearthed From : A tomb at Xishan of Yemaotai in Faku county, Liaoning province Collected By : Liaoning Provincial Museum Date (AD) : late Published : Shanhai renmin meishu chubanshe ed. 1986, pl. 27.</p>	 <p>Cat. 417</p>
<p>Catalogue No. : Cat. 418 Type : Aa Body : porcelain Glaze : white Decoration : Carved Plantain leaves design on the body. Size (cm) : Height: 19.2; Diameter of mouth: 3.4; Diameter of base: 7.6. Unearthed From : Tomb at Tangjiazhangzi, Jianping city, Liaoning province Collected By : Research institute of Relics and Archaeology of Liaoning province Date (AD) : late Published : Lü Xueming 1997, 24-29, fig. 7:1.</p>	 <p>Cat. 418</p>
<p>Catalogue No. : Cat. 419 Type : Aa Body : porcelain Glaze : white Decoration : Carved Plantain leaves design on the body. Size (cm) : Height: 21.6. Unearthed From : MTYZ1 Collected By : Date (AD) : late Published : Zheng Long 1981, 231-43.</p>	 <p>Cat. 419</p>

<p>Catalogue No. : Cat. 420 Type : Aa Body : porcelain Glaze : white Decoration : Carved Plantain leaves design on the body. Size (cm) : Height: 16.8, Diameter of mouth: 3.5. Unearthed From : Collected By : Liaoning Provincial Museum Date (AD) : Published : Shanhai renmin meishu chubanshe ed. 1986, pl 9.</p>	 <p>Cat. 420</p>
<p>Catalogue No. : Cat. 421 Type : Aa Body : porcelain Glaze : white Decoration : Carved Plantain leaves design on the body. Size (cm) : Height: 17.2, Diameter of mouth: 3.7; Diameter of base: 7.9. Unearthed From : Collected By : Liaoning provincial museum Date (AD) : Published : Liaoningsheng bowuguan 1961, pl. 37.</p>	 <p>Cat. 421</p>
<p>Catalogue No. : Cat. 422 Type : Aa Body : porcelain Glaze : white Decoration : Carved Plantain leaves design on the body. Size (cm) : Height: 19; Diameter of mouth: 2.8; Diameter of base: 8.3. Unearthed From : A tomb at Yaojiagou, Jinchanggouliang township, Aohan Banner, Inner Mongolia Collected By : Aohan Banner Museum Date (AD) : late Published : Shao Guotian ed. 2004, pl. 126.</p>	  <p>Cat. 422</p>
<p>Catalogue No. : Cat. 423 Type : Aa Body : Pinkish erathenware Glaze : Yellow Decoration : Size (cm) : Height: 19. Unearthed From : Collected By : Chinese privat collection Date (AD) : Published : Lu Jing 2003, Pl. 19.</p>	 <p>Cat. 423</p>

<p>Catalogue No. : Cat. 424 Type : Aa Body : Pinkish erathenware Glaze : green Decoration : Size (cm) : Height: 16.5; Diameter of mouth: 4; Diameter of base: 6.6. Unearthed From : XHD Collected By : Date (AD) : middle Published : Wang Gang 1998, 44-9, fig.4:1.</p>	 <p>Cat. 424</p>
<p>Catalogue No. : Cat. 425 Type : Aa Body : Pinkish erathenware Glaze : Three-color Decoration : Moulded rolling dragon and phoenix designs on the body; and lotus petals designs on the neck and lower belly. Size (cm) : Height: 18; Diameter of mouth: 2.9; Diameter of base: 6.9. Unearthed From : Collected By : Liaoning Provincial Museum Date (AD) : late Published : Zhongguo taoci quanji bianji weiyuanhui 1999, pl. 99.</p>	 <p>Cat. 425</p>
<p>Catalogue No. : Cat. 426 Type : Aa Body : Pinkish erathenware Glaze : Three-color Decoration : Moulded rolling dragon and phoenix designs on the body; and lotus petals designs on the neck and lower belly. Size (cm) : Height: 20.8. Unearthed From : Collected By : Chinese privat collection Date (AD) : late Published : Lu Jing 2003, pl. 3-173.</p>	 <p>Cat. 426</p>
<p>Catalogue No. : Cat. 427 Type : Aa Body : Pinkish erathenware Glaze : yellow Decoration : Moulded rolling dragon and phoenix designs on the body; and lotus petals designs on the neck and lower belly. Size (cm) : Height: 19.8 Unearthed From : Collected By : Chinese privat collection Date (AD) : late Published :</p>	 <p>Cat. 427</p>

Catalogue No. : Cat. 428

Type : Aa

Body : Pinkish earthenware

Glaze : Three- color

Decoration : Moulded rolling dragon waves designs on the body; and geometric and floral designs on the neck and lower belly.

Size (cm) : Height: 19.2; Diameter of mouth: 3.8; Diameter of base: 8.6.

Unearthed From :

Collected By : Guan Baocong collection

Date (AD) : late

Published : Lu Jing 2003, pl. 4-202.



Cat. 428

Catalogue No. : Cat. 429

Type : Aa

Body : Pinkish earthenware

Glaze : Three- color

Decoration : Moulded rolling dragon and waves designs on the body; and geometric and floral designs on the neck and lower belly.

Size (cm) : Height: 18.8; Diameter of mouth: 3.5; Diameter of base: 7.8.

Unearthed From : QJG1

Collected By : Chifeng municipal museum, Inner Mongolia

Date (AD) : late

Published : Neimenggu zizhiqu wenhuating & Zhongguo lishi bowuguan 2002, pl. 293; Shanghai bowuguan 2000, pl.185; Shen Hsueh-man et al. 2006, pl. 91; Xiang Chunsong 1991, 33-9, fig.4:right.



Cat. 429

Catalogue No. : Cat. 430

Type : Ab

Body : porcelain

Glaze : white

Decoration : Ribbed neck. Carved overlapping lotus petals on the body.

Size (cm) : Height: 21.5.

Unearthed From : GYY





Collected By :

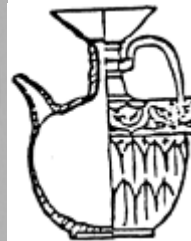

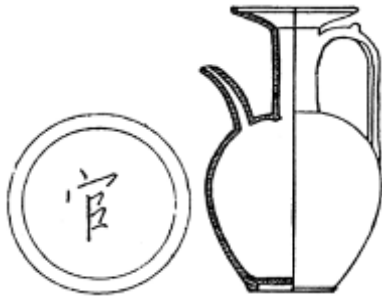

Date (AD) : 1020

Published : Zhu Zifang & Xu Ji 1983, 168-95, fig. 20:4.



Cat. 430

<p>Catalogue No. : Cat. 431 Type : Ab Body : Buff stoneware Glaze : green Decoration : Ribbed neck. Size (cm) : Height: 17.1. Unearthed From : Collected By : Tokyo national museum Date (AD) : Published : Sugimura Yuzo 1974, pl. 43.</p>	 <p>Cat. 431</p>
<p>Catalogue No. : Cat. 432 Type : Ab Body : porcelain Glaze : white Decoration : Size (cm) : Height: 26.3. Unearthed From : QHM2 Collected By : Date (AD) : 1057 Published : Li Wenxin 1954, 163-202.</p>	 <p>Cat. 432</p>
<p>Catalogue No. : Cat. 433 Type : Ab Body : porcelain Glaze : white Decoration : Size (cm) : Height: 25.4. Unearthed From : QHM2 Collected By : Date (AD) : 1057 Published : Li Wenxin 1954, 163-202, fig.12:2.</p>	 <p>Cat. 433</p>
<p>Catalogue No. : Cat. 434 Type : Ab Body : porcelain Glaze : white Decoration : Size (cm) : Height: 25; Diameter of mouth: 12; Diameter of base: 7.8. Unearthed From : Collected By : Liaoning Provincial Museum Date (AD) : Published : Shanghai renmin meishu chubanshe ed. 1986, pl. 65; Liaoningsheng bowuguan 1961, pl. 35.</p>	 <p>Cat. 434</p>

<p>Catalogue No. : Cat. 435 Type : Body : porcelain Glaze : white Decoration : With phoenix head under the lobed dish-mouth Size (cm) : Height: 24.5. Unearthed From : a tomb at Luanping, Hebei Collected By : Date (AD) : Published : Zhao Zhihou 1981, 43, fig.2.</p>	 <p>Cat. 435</p>
<p>Catalogue No. : Cat. 436 Type : B Body : porcelain Glaze : white Decoration : Ribbed neck Size (cm) : Height: 28.2. Unearthed From : YMT7 Collected By : Liaoning provincial museum Date (AD) : 977 Published : Feng Yongqian 1975, 40-48, fig. 5:5; Xu Bingkun & Sun Shoudao ed. 1998, pl. 230.</p>	 <p>Cat. 436</p>
<p>Catalogue No. : Cat. 437 Type : B Body : porcelain Glaze : white Decoration : Ribbed neck Size (cm) : Height: 26.5; Diameter of mouth: 11.7.. Unearthed From : YMT7 Collected By : Liaoning provincial museum Date (AD) : 977 Published : Shanghai renmin meishu chubanshe ed. 1986, pl. 121</p>	 <p>Cat. 437</p>
<p>Catalogue No. : Cat. 438 Type : B Body : porcelain Glaze : white Decoration : Ribbed neck Size (cm) : Height: 27.7; Diameter of mouth: 10.7; Diameter of belly: 14.2; Diameter of base: 8.2.. Unearthed From : YMT7 Collected By : Liaoning provincial museum Date (AD) : 977 Published : Zhongguo taoci quanji bianji weiyuanhui 1999, pl. 15; Feng Yongqian 1975, 40-8, fig.5:5.</p>	 <p>Cat. 438</p>

Catalogue No. : Cat. 439
 Type : B
 Body : porcelain
 Glaze : white
 Decoration : Incised circles on the neck
 Size (cm) : Height: 27.3.
 Unearthed From : SQ1
 Collected By : Liaoning provincial museum
 Date (AD) : middle
 Published : Xu Yulin 1977, 44-51, fig. 23:5

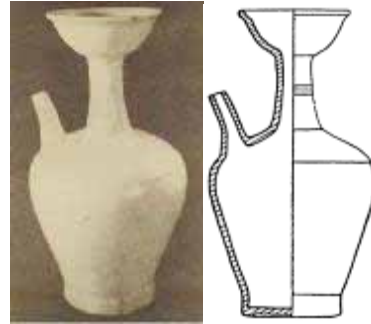

Cat. 439

Catalogue No. : Cat. 440
 Type : B
 Body : Pinkish earthenware
 Glaze : green
 Decoration : Ribbed neck.
 Size (cm) : Height: 31.7; Diameter of mouth: 11.3;
 Diameter of belly: 15.5; Diameter of base: 9.4.
 Unearthed From :
 Collected By : Liaoning provincial museum
 Date (AD) : middle
 Published : Zhongguo taoci quanji bianji weiyuanhui
 1999, pl. 87; Liaoningsheng bowuguan 1961, pl.30.



Cat. 440

Catalogue No. : Cat. 441
 Type : B
 Body : Pinkish earthenware
 Glaze : white
 Decoration : Ribbed neck.
 Size (cm) : Height: 27.
 Unearthed From : XTTG3
 Collected By :
 Date (AD) : middle
 Published : Qi Xiaoguang 1991, 68-71.











Cat. 441



Catalogue No. : Cat. 442
 Type : B
 Body : porcelain
 Glaze : white
 Decoration : Ribbed neck. Carved overlapping lotus petals decorated on the body.
 Size (cm) : Height: 29.4; Diameter of mouth: 10.4;
 Diameter of base: 8.3.
 Unearthed From :
 Collected By : Liaoning Provincial Museum.
 Date (AD) : middle
 Published : Mok 1985, pl. 76; Liaoningsheng
 bowuguan 1961, pl. 31.







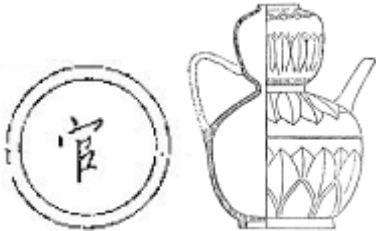

Cat. 442

<p>Catalogue No. : Cat. 443 Type : B Body : Buff stoneware Glaze : white Decoration : Lobbed nouth. Size (cm) : Height: 27.9. Unearthed From : Collected By : Royal Ontario Museum, Toronto Date (AD) : Published : Mino Yutaka et al. 1973, pl. 39; Mok 1985, pl. 74</p>	 <p>Cat. 443</p>
<p>Catalogue No. : Cat. 444 Type : B Body : Buff stoneware Glaze : white Decoration : Lobbed nouth. Size (cm) : Height: 27.5; Diameter of mouth: 9; Diameter of base: 8.4. Unearthed From : Collected By : Guan Baocong collection Date (AD) : Published : Lu Jing 2003, 4-71.</p>	 <p>Cat. 444</p>
<p>Catalogue No. : Cat. 445 Type : B Body : porcelain Glaze : white Decoration : Carved floral designs on the body. Size (cm) : Height: 32.8; Diameter of mouth: 8.4; Diameter of base: 8.2. Unearthed From : Collected By : The palace museum, Peking Date (AD) : Published : Zhongguo taoci quanji bianji weiyuanhui 1999, pl. 2.</p>	 <p>Cat. 445</p>
<p>Catalogue No. : Cat. 446 Type : B Body : porcelain Glaze : white Decoration : Carved floral designs on the body. Size (cm) : Height: 31.4. Unearthed From : a tomb at Tongliao, Jilin province Collected By : Date (AD) : Published : Mok 1985, pl. 75.</p>	 <p>Cat. 446</p>

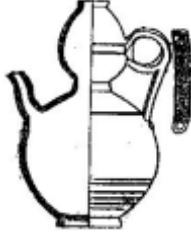
<p>Catalogue No. : Cat. 447 Type : B Body : Buff stoneware Glaze : white Decoration : Ribbed neck. Size (cm) : Height: 31.2; Diameter of mouth: 10.9. Unearthed From : XDM Collected By : Chifeng wenhuaguan wenwuzu Date (AD) : late Published : Xiang Chunsong 1991, 33-39; Shanghai renmin meishu chubanshe ed. 1986, pl. 87.</p>	 <p>Cat. 447</p>
<p>Catalogue No. : Cat. 448 Type : B Body : Buff stoneware Glaze : white Decoration : Ribbed neck; lobed mouth. Size (cm) : Height: 32.3; Diameter of mouth: 10; Diameter of base: 8.2. Unearthed From : a tomb at Yezhushan, Mutouyingzi Township, Aohan Banner, Inner Mongolia Collected By : Aohan Banner Museum, Inner Mongolia Date (AD) : late Published : Shao Guotian ed. 2004, pl. 133-2</p>	 <p>Cat. 448</p>
<p>Catalogue No. : Cat. 449 Type : B Body : Buff stoneware Glaze : white Decoration : Ribbed neck. Size (cm) : Height: 34; Diameter of mouth: 10.6. Unearthed From : Collected By : Lianing provincial museum Date (AD) : Published : Shanghai renmin meishu chubanshe ed. 1986, pl. 77.</p>	 <p>Cat. 449</p>
<p>Catalogue No. : Cat. 450 Type : B Body : Buff stoneware Glaze : white Decoration : Ribbed neck; lobed mouth. Size (cm) : Height: 28.6. Unearthed From : Collected By : Chinese privat collection Date (AD) : late Published : Lu Jing 2003 pl. 205.</p>	 <p>Cat. 450</p>

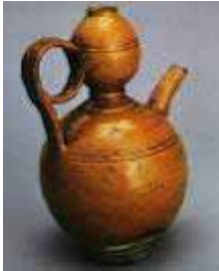



<p>Catalogue No. : Cat. 451 Type : B Body : Buff stoneware Glaze : white Decoration : Ribbed neck; lobed mouth. Size (cm) : Height: 29.7. Unearthed From : Collected By : Chinese privat collection Date (AD) : late Published : Lu Jing 2003 pl. 206.</p>	 <p>Cat. 451</p>
<p>Catalogue No. : Cat. 452 Type : Ca Body : porcelain Glaze : white Decoration : Carved overlapping lotus petals decorated on the body. incised "Guan" mark on the bottom. Size (cm) : Height: 20.4. Unearthed From : HLDT2 Collected By : Date (AD) : early Published : Zhang Shaoqing 1988, 819-24, fig.3:3.</p>	 <p>Cat. 452</p>
<p>Catalogue No. : Cat. 453 Type : Ca Body : Buff stoneware Glaze : green Decoration : Size (cm) : Height: 14.9; Diameter of belly: 10.1. Unearthed From : Collected By : Seattle At Museum Eugene Fuller Memorial Collection Date (AD) : early Published : Mino Yutaka et al. 1973, pl. 17.</p>	 <p>Cat. 453</p>
<p>Catalogue No. : Cat. 454 Type : Ca Body : Buff stoneware Glaze : brown Decoration : Size (cm) : Height: 14.1; Diameter of mouth: 3; Diameter of base: 4.9. Unearthed From : PJG2 Collected By : Aohan Banner Museum Date (AD) : late Published : Ji Ping 1997, 639-50, fig.12:3; Shao Guotian ed. 2004, pl. 128-1.</p>	 <p>Cat. 454</p>



<p>Catalogue No. : Cat. 455 Type : Ca Body : porcelain Glaze : white Decoration : Size (cm) : Height: 32. Unearthed From : KL1 Collected By : Date (AD) : 1080 Published : Chen Xiangwei & Wang Jianqun 1973, 2-18,fig. 6:8.</p>	 <p>Cat. 455</p>
<p>Catalogue No. : Cat. 456 Type : Ca Body : Buff stoneware Glaze : brown Decoration : Size (cm) : Height: 15. Unearthed From : a tomb at Helihaolai, Naiman Banner, Inner Mongolia Collected By : Jilin Provincial Museum Date (AD) : late Published : Lu Jing 2003, pl. 3-182.</p>	 <p>Cat. 456</p>
<p>Catalogue No. : Cat. 457 Type : Ca Body : Buff stoneware Glaze : white Decoration : Carved scales design on the body. Size (cm) : Height: 13.2. Unearthed From : a tomb at Fengtai, Beijing Collected By : Capital Museum, Beijing Date (AD) : Published : Shoudu bowuguan 1991, pl.40.</p>	 <p>Cat. 457</p>
<p>Catalogue No. : Cat. 458 Type : Ca Body : Pinkish earthenware Glaze : white Decoration : Incised circles on the body; Impressed floral designs on the handle. Size (cm) : Height: 26.3. Unearthed From : BL3 Collected By : Date (AD) : late Published : Wu Jiachang 1986, 32-51, fig.16:3.</p>	 <p>Cat. 458</p>





<p>Catalogue No. : Cat. 459 Type : Ca Body : Pinkish earthenware Glaze : yellow Decoration : Incised circles on the body; Impressed floral designs on the handle. Size (cm) : Height: 16. Unearthed From : A tomb at Shanzuizi commune of Kazuo county, Liaoning province Collected By : Liaoning Provincial Museum Date (AD) : late Published : Shanghai renmin meishu chubanshe ed. 1986, pl. 81.</p>	 <p>Cat. 459</p>
<p>Catalogue No. : Cat. 460 Type : Ca Body : Pinkish earthenware Glaze : yellow Decoration : Incised circles on the body; Impressed floral designs on the handle. Size (cm) : Height: 17.6; Diameter of mouth: 2.6; Diameter of base: 6.2. Unearthed From : Collected By : Liaoning Provincial Museum Date (AD) : late Published : Zhongguo taoci quanji bianji weiyuanhui 1999, pl. 68.</p>	 <p>Cat. 460</p>
<p>Catalogue No. : Cat. 461 Type : Ca Body : Pinkish earthenware Glaze : yellow Decoration : Incised circles on the body; Impressed floral designs on the handle. Size (cm) : Height: 25.6; Diameter of mouth: 3.1; Diameter of base: 7.8. Unearthed From : Collected By : Liaoning Provincial Museum Date (AD) : late Published : Liaoningsheng bowuguan 1961, pl. 4.</p>	 <p>Cat. 461</p>
<p>Catalogue No. : Cat. 462 Type : Ca Body : Pinkish earthenware Glaze : yellow Decoration : Incised circles on the body; Impressed floral designs on the handle. Size (cm) : Height: 23.8. Unearthed From : Collected By : Tokyo National Museum Date (AD) : late Published : Sugimura Yuzo 1974, pl. 5.</p>	 <p>Cat. 462</p>



<p>Catalogue No. : Cat. 463 Type : Ca Body : Pinkish earthenware Glaze : yellow Decoration : Incised circles on the body; Impressed floral designs on the handle. Size (cm) : Height: 19.2. Unearthed From : Collected By : ? Art Museum, Japan Date (AD) : late Published : Sugimura Yuzo 1974, pl. 44.</p>	 <p>Cat. 463</p>
<p>Catalogue No. : Cat. 464 Type : Ca Body : Pinkish earthenware Glaze : yellow Decoration : Incised circles on the body; Impressed floral designs on the handle. Size (cm) : Height: 17.6; Diameter of mouth: 2.6; Diameter of base: 6.2. Unearthed From : Collected By : Guan Baocong collection Date (AD) : late Published : Lu Jing 2003, pl 4-134.</p>	 <p>Cat. 464</p>
<p>Catalogue No. : Cat. 465 Type : Ca Body : Pinkish earthenware Glaze : yellow Decoration : Incised circles on the body; Impressed floral designs on the handle. Size (cm) : Height: 26.7; Diameter of mouth: 3.2; Diameter of base: 8.3. Unearthed From : A tomb at Kunduling, Shuiquan Township, Kulun Banner, Inner Mongolia Collected By : Tongliao Museum, Inner Mongolia Date (AD) : late Published : Neimenggu zizhiqu wenhuating & Zhongguo lishi bowuguan 2002, pl. 277.</p>	 <p>Cat. 465</p>
<p>Catalogue No. : Cat. 466 Type : Ca Body : Pinkish earthenware Glaze : yellow Decoration : Incised circles on the body; Impressed floral designs on the handle. Size (cm) : Height: 18.5; Diameter of mouth: 3; Diameter of base: 6.2. Unearthed From : a tomb at Xiaokengzi, Niugutu Township, Aohan Banner, Inner Mongolia Collected By : Aohan Banner Museum, Inner Mongolia Date (AD) : late Published : Shao Guotian ed. 2004, pl. 128-2.</p>	 <p>Cat. 466</p>



<p>Catalogue No. : Cat. 467 Type : Ca Body : Pinkish earthenware Glaze : yellow Decoration : Incised circles on the body; Impressed floral designs on the handle. Size (cm) : Height: 17.5; Diameter of mouth: 3; Diameter of base: 6.6. Unearthed From : Collected By : Aohan Banner Museum, Inner Mongolia Date (AD) : late Published : Shao Guotian ed. 2004, pl. 128-3.</p>	 <p>Cat. 467</p>
<p>Catalogue No. : Cat. 468 Type : Ca Body : Pinkish earthenware Glaze : yellow Decoration : Incised circles on the body; Impressed floral designs on the handle. Size (cm) : Height: 21.8; Diameter of mouth: 2.5. Unearthed From : Collected By : Chifeng municipal museum, Inner Mongolia Date (AD) : Published : Shanghai renmin meishu chubanshe ed. 1986, pl. 6.</p>	 <p>Cat. 468</p>
<p>Catalogue No. : Cat. 469 Type : Ca Body : Buff stoneware Glaze : white Decoration : Incised circles on the body; Impressed floral designs on the handle. Size (cm) : Height: 21.7; Diameter of mouth: 2.7; Diameter of base: 7.1. Unearthed From : Collected By : Guan Baocong Collection Date (AD) : late Published : Lu Jing 2003, 4-72.</p>	 <p>Cat. 469</p>
<p>Catalogue No. : Cat. 470 Type : Ca Body : porcelain Glaze : white Decoration : Dragon head shaped spout Size (cm) : Height: 23.2; Diameter of mouth: 2.8; Diameter of base: 8.2. Unearthed From : a tomb at Yangchang Township, Baling Right Banner, Inner Mongolia Collected By : Balin Right Banner Museum, Inner Mongolia Date (AD) : late Published : Lu Jing 2003, 3-183; Shanghai bowuguan 2000, pl. 175.</p>	 <p>Cat. 470</p>



<p>Catalogue No. : Cat. 471 Type : Ca Body : Pinkish earthenware Glaze : green Decoration : Incised circles on the body; Impressed floral designs on the handle. Size (cm) : Height: 25.3. Unearthed From : Collected By : Chinese privat collection Date (AD) : late Published : Lu Jing 2003, pl. 3-188</p>	 <p>Cat. 471</p>
<p>Catalogue No. : Cat. 472 Type : Ca Body : Stoneware Glaze : white Decoration : Black pigment painted on the body Size (cm) : Height: 12.2; Diameter of mouth: 3.4; Diameter of base: 6. Unearthed From : a tomb at Haoertu Township, Banlin Left Banner, Inner Mongolia Collected By : Liaoshangjing Museum, Inner Mongolia Date (AD) : late Published : Tang Cailan 2005, pl. 57-2.</p>	 <p>Cat. 472</p>
<p>Catalogue No. : Cat. 473 Type : Ca Body : Stoneware Glaze : white Decoration : Size (cm) : Height: 11.6; Diameter of mouth: 2.6; Diameter of base: 6.5. Unearthed From : Collected By : Liaoning provincial museum Date (AD) : late Published : Liaoningsheng bowuguan 1961, pl. 38.</p>	 <p>Cat. 473</p>
<p>Catalogue No. : Cat. 474 Type : Ca Body : Stoneware Glaze : white Decoration : Black pigment painted on the body Size (cm) : Height: 11; Diameter of mouth: 3; Diameter of base: 5.8. Unearthed From : Collected By : Guan Baocong collection Date (AD) : late Published : Lu Jing 2003, pl. 4-235.</p>	 <p>Cat. 474</p>

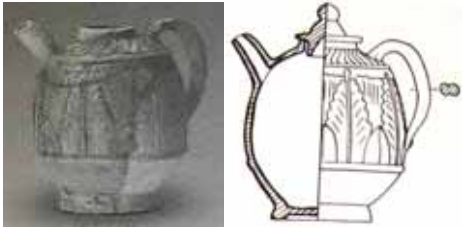
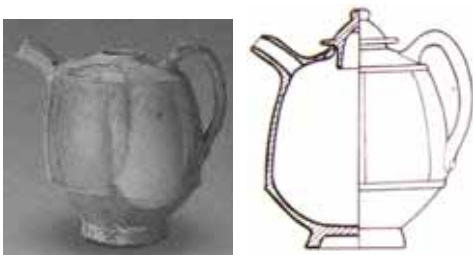

<p>Catalogue No. : Cat. 475 Type : Ca Body : Stoneware Glaze : brown Decoration : Size (cm) : Height: 12; Diameter of mouth: 3; Diameter of base: 6.5. Unearthed From : Collected By : Guan Baocong collection Date (AD) : late Published : Lu Jing 2003, pl 4-117.</p>	 <p>Cat. 475</p>
<p>Catalogue No. : Cat. 476 Type : Cb Body : Pinkish earthenware Glaze : green Decoration : Impressed waves design on the lobed body Size (cm) : Height: 18.2; Diameter of mouth: 4.2. Unearthed From : a tomb at Gushanzi village, Sanjia Township, Kazuo county, Liaoning Province Collected By : Kazuo museum, Chaoyang city, Liaoning province Date (AD) : early Published : Zhongguo taoci quanji bianji weiyuanhui 1999, pl. 90; Shanhai renmin meishu chubanshe ed. 1986, pl. 5.</p>	 <p>Cat. 476</p>
<p>Catalogue No. : Cat. 477 Type : Cb Body : Pinkish earthenware Glaze : green Decoration : Impressed waves design on the lobed body Size (cm) : Unearthed From : Collected By : Date (AD) : early Published :</p>	 <p>Cat. 477</p>
<p>Catalogue No. : Cat. 478 Type : Cb Body : Pinkish earthenware Glaze : green Decoration : Impressed waves design on the lobed body Size (cm) : Height: 14.2; Diameter of mouth: 3.6; Diameter of base: 6.5. Unearthed From : a tomb at Xigou, Linjiadi Township, Aohan Banner, Inner Mongolia Collected By : Aohan Banner Museum, Inner Mongolia Date (AD) : early Published : Shao Guotian ed. 2004, pl. 127-2.</p>	 <p>Cat. 478</p>

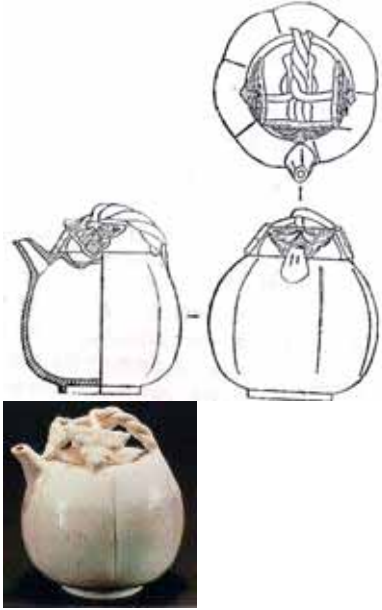

<p>Catalogue No. : Cat. 479 Type : Cb Body : Pinkish earthenware Glaze : green Decoration : Impressed waves design on the lobed body Size (cm) : Height: 11. Unearthed From : Collected By : Collections of P.R. China Date (AD) : early Published : Lu Jing 2003, pl 3-193.</p>	 <p>Cat. 479</p>
<p>Catalogue No. : Cat. 480 Type : Cb Body : Pinkish earthenware Glaze : yellow Decoration : Size (cm) : Height: 13.5. Unearthed From : ZWZ Collected By : Date (AD) : 1093 Published : Zheng Shaozong 1996, 14-46, fig.21:2.</p>	 <p>Cat. 480</p>
<p>Catalogue No. : Cat. 481 Type : Cb Body : Pinkish earthenware Glaze : yellow Decoration : Size (cm) : Height: 16.8 Unearthed From : ZKZ Collected By : Date (AD) : 1093 Published : Hebeisheng wenwu yanjiusuo et al 1995, 1-22.</p>	 <p>Cat. 481</p>
<p>Catalogue No. : Cat. 482 Type : Cb Body : Pinkish earthenware Glaze : yellow Decoration : Size (cm) : Height: 16. Unearthed From : ZSB Collected By : Date (AD) : 1115-1144 Published : Tao Zongyi et al 1990, 1-19, fig.27:10</p>	 <p>Cat. 482</p>

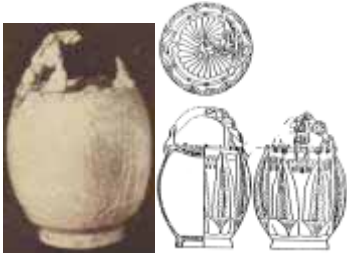



<p>Catalogue No. : Cat. 483 Type : Cb Body : porcelain Glaze : white Decoration : Carved plantain leaves designs Size (cm) : Unearthed From : LQW kiln site, Beijing Collected By : Research Institute of Relics of Beijing Date (AD) : late Published : Beijingshi wenwu yanjiusuo 2002, pl.5:1.</p>	 <p>Cat. 483</p>
<p>Catalogue No. : Cat. 484 Type : Cb Body : porcelain Glaze : white Decoration : Carved plantain leaves designs Size (cm) : Height: 14. Unearthed From : Collected By : Mengdiexuan Collection Date (AD) : late Published : So 2004, pl. : 28.</p>	 <p>Cat. 484</p>
<p>Catalogue No. : Cat. 485 Type : Cb Body : porcelain Glaze : yellow Decoration : Carved plantain leaves designs Size (cm) : Height: 17. Unearthed From : LQW kiln site, Beijing Collected By : Research Institute of Relics of Beijing Date (AD) : late Published : Beijingshi wenwu yanjiusuo 2002, 284-5, fig.97:3, pl. 98:1.</p>	 <p>Cat. 485</p>
<p>Catalogue No. : Cat. 486 Type : Cb Body : porcelain Glaze : white Decoration : Carved plantain leaves designs Size (cm) : Height: 16.8. Unearthed From : LQW kiln site, Beijing Collected By : Research Institute of Relics of Beijing Date (AD) : late Published : Beijingshi wenwu yanjiusuo 2002, 284-5, fig.97:4, pl. 98:2.</p>	 <p>Cat. 486</p>



<p>Catalogue No. : Cat. 487 Type : Cb Body : porcelain Glaze : white Decoration : Carved plantain leaves designs Size (cm) : Height: 17.2. Unearthed From : LQW kiln site, Beijing Collected By : Research Institute of Relics of Beijing Date (AD) : late Published : Beijingshi wenwu yanjiusuo 2002, 284-5, fig.97:5, pl. 98:3.</p>	 <p>Cat. 487</p>
<p>Catalogue No. : Cat. 488 Type : Cc Body : Porcelain Glaze : white Decoration : Size (cm) : Height: 1e; Diameter of mouth: 1.5. Unearthed From : A tomb at Longjiang county, Heilongjiang province Collected By : Heilongjiang Wenwu kaogu dui Date (AD) : late Published : Shanghai renmin meishu chubanshe ed. 1986, pl. 84.</p>	 <p>Cat. 488</p>
<p>Catalogue No. : Cat. 489 Type : Cc Body : Porcelain Glaze : white Decoration : Size (cm) : Height: 13. Unearthed From : HQY6 Collected By : Date (AD) : late Published : Lu Sixian & Du Chengwu 1983, 1-8, fig. 18,19.</p>	 <p>Cat. 489</p>



<p>Catalogue No. : Cat. 490 Type : Cd Body : Porcelain Glaze : white Decoration : Carved relief peony scroll and incised butterflies on the body Size (cm) : Height: 12.5. Unearthed From : a tomb at Balin Right Banner ,Inner Mongolia Collected By : Collections of P.R.China Date (AD) : late Published : Zhongguo taoci quanji bianji weiyuanhui 1999, pl. 16-1.</p>	 <p>Cat. 490</p>
<p>Catalogue No. : Cat. 491 Type : Cd Body : Porcelain Glaze : white Decoration : Carved relief peony scroll and incised butterflies on the body Size (cm) : Height: 12.5; Diameter of belly: 9.5. Unearthed From : a tomb at Nanlinzi, Liaoyang, Liaoning province Collected By : Liaoning Provincial Museum Date (AD) : late Published : Liaoyangshi wenwu guanlisuo 1977, 90-91; Zhongguo taoci quanji bianji weiyuanhui 1999, pl. 16; Shanghai renmin meishu chubanshe ed. 1986, pl.79.</p>	 <p>Cat. 491</p>
<p>Catalogue No. : Cat. 492 Type : Cd Body : Porcelain Glaze : white Decoration : Carved Plantain leaves in relief on the body Size (cm) : Height: 22.2. Unearthed From : ZKY Collected By : Date (AD) : 1060 Published : Deng Baoxue et al. 1983, 30-38, fig. 17.</p>	 <p>Cat. 492</p>

<p>Catalogue No. : Cat. 493 Type : Ce Body : Porcelain Glaze : white Decoration : Melon-shaped body with seven shallow lobes. Bucket-type handle of three strands partly uncovered, the end of each strand attached to molded flower medallion on rim above curved spout. Size (cm) : Height: 14.5; Diameter of mouth: 5. Unearthed From : Collected By : Datong Municipal museum, Shanxi province Date (AD) : late Published : Zhongguo taoci quanji bianji weiyuanhui 1999, pl. 9.</p>	 <p>Cat. 493</p>
<p>Catalogue No. : Cat. 494 Type : Ce Body : Porcelain Glaze : white Decoration : Melon-shaped body with seven shallow lobes. Bucket-type handle of three strands partly uncovered, the end of each strand attached to molded flower medallion on rim above curved spout. Size (cm) : Height: 16. Unearthed From : a hoard at Sangou village in Chengde city, Hebei Province Collected By : Date (AD) : late Published : Feng Yongqian 1981c, 65-71, fig.7.</p>	 <p>Cat. 494</p>
<p>Catalogue No. : Cat. 495 Type : Ce Body : Porcelain Glaze : white Decoration : Melon-shaped body with seven shallow lobes. Bucket-type handle of three strands partly uncovered, the end of each strand attached to molded flower medallion on rim above curved spout. Size (cm) : Height: 14.9; Diameter of belly: 9,3.. Unearthed From : Collected By : Royal Ontario Museum, Toronto Date (AD) : late Published : Mino Yutaka et al. 1973, pl. 49.</p>	 <p>Cat. 495</p>





<p>Catalogue No. : Cat. 496 Type : Ce Body : Porcelain Glaze : white Decoration : Melon-shaped body with seven shallow lobes. Bucket-type handle of three strands partly uncovered, the end of each strand attached to molded flower medallion on rim above curved spout. Size (cm) : Height: 16.5. Unearthed From : Collected By : Royal Ontario Museum, Toronto Date (AD) : late Published : Mino Yutaka et al. 1973, pl.50.</p>	 <p>Cat. 496</p>
<p>Catalogue No. : Cat. 497 Type : Ce Body : Porcelain Glaze : white Decoration : Melon-shaped body with seven shallow lobes. Bucket-type handle of three strands partly uncovered, the end of each strand attached to molded flower medallion on rim above curved spout. Size (cm) : Height: 15.8 Unearthed From : Collected By : Date (AD) : late Published : Mok 1985, pl. 71.</p>	 <p>Cat. 497</p>
<p>Catalogue No. : Cat. 498 Type : Ce Body : Porcelain Glaze : white Decoration : Melon-shaped body with seven shallow lobes. Bucket-type handle of three strands partly uncovered, the end of each strand attached to molded flower medallion on rim above curved spout. Size (cm) : Height: 14.2; Diameter of mouth: 3.6; Diameter of base: 4.5.. Unearthed From : Collected By : Guan Baocong collection Date (AD) : late Published : Lu Jing 2003, pl. 4-82.</p>	 <p>Cat. 498</p>

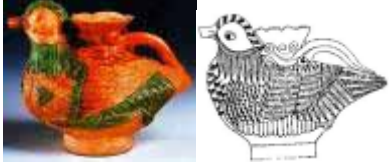

<p>Catalogue No. : Cat. 499 Type : Cf Body : Buff stoneware Glaze : green Decoration : impressed eye-like ornaments and wave patterns Size (cm) : Height: 18.2. Unearthed From : the Foundations of a pagoda at Dingxian, Hebei Collected By : Center of Asian Art and Culture, Avery Brundage Collection, San Francisco, California Date (AD) : 977 Published : Mok 1985, pl. 44; Mino Yutaka et al. pl. 57.</p>	 <p>Cat. 499</p>
<p>Catalogue No. : Cat. 500 Type : Cf Body : Buff stoneware Glaze : white Decoration : Applied designs in relief on the cover. Size (cm) : Height: 18.5; Diameter of mouth: 4.5. Unearthed From : a tomb at Majiabao village, Datong city, Inner Mongolia Collected By : Datong municipal museum, Shanxi province Date (AD) : Published : Zhongguo taoci quanji bianji weiyuanhui 1999, pl. 13.</p>	 <p>Cat. 500</p>
<p>Catalogue No. : Cat. 501 Type : Cf Body : porcelain Glaze : white Decoration : with melon-shaped lobed body and vegetable-shaped handle ending in a palmette. Size (cm) : Height: 11. Unearthed From : Collected By : Museum of Far Eastern Antiquities: Carlkempe Collection, Stockholm; Museum of Far Eastern Antiquities: Kempe Coll., Stockholm (386) Date (AD) : Published : Mok 1985, pl. 72; Watson 1984, pl. 276.</p>	 <p>Cat. 501</p>
<p>Catalogue No. : Cat. 502 Type : Cf Body : Buff stoneware Glaze : green Decoration : In the form of melon Size (cm) : Height: 14.5; diameter of mouth: 5.5. Unearthed From : Collected By : Liaoning Provincial Museum Date (AD) : early Published : Shanghai renmin meishu chubanshe ed. 1986, pl. 34; Liaoningsheng bowuguan 1961, pl. 33.</p>	 <p>Cat. 502</p>

<p>Catalogue No. : Cat. 503 Type : Da Body : Pinkish earthenware Glaze : Three-colored Decoration : In form of a dragon-fish with Moulded designs Size (cm) : Height: 21.1; Length: 30.4; width: 11.8; Diameter of base: 9.2. Unearthed From : A tomb at Yusi Township, Fuxin city, Liaoning province Collected By : Fuxin municipal museum, Liaoning Province Date (AD) : late Published : Zhongguo taoci quanji bianji weiyuanhui 1999, pl. 122.</p>	 <p>Cat. 503</p>
<p>Catalogue No. : Cat. 504 Type : Da Body : Pinkish earthenware Glaze : Three-colored Decoration : In form of a dragon-fish with Moulded designs Size (cm) : Height: 22.3; Length: 30; Diameter of base: 9. Unearthed From : A tomb at Kerzuo Central Banner, Inner Mongolia Collected By : Tongliao Municipal Museum, Inner Mongolia Date (AD) : late Published : Neimenggu zizhiqiu wenhuating & Zhongguo lishi bowuguan 2002, pl. 286; Shanghai bowuguan 2000, pl. 183; Shen Hsueh-man et al. 2006, pl. 113.</p>	 <p>Cat. 504</p>
<p>Catalogue No. : Cat. 505 Type : Db Body : Pinkish earthenware Glaze : Three-colored Decoration : In the form of fish with moulded designs Size (cm) : Height: 25.5. Unearthed From : A tomb at Yushulinzi, Ningcheng County, Inner Mongolia Collected By : Chifeng municipal museum Date (AD) : late Published : Neimenggu zizhiqiu wenhuating & Zhongguo lishi bowuguan 2002, pl. 283.</p>	 <p>Cat. 505</p>



<p>Catalogue No. : Cat. 506 Type : Db Body : Pinkish earthenware Glaze : Three-colored Decoration : In the form of fish with moulded designs Size (cm) : Height: 25. Unearthed From : A tomb at Ningcheng County, Inner Mongolia Collected By : Liaozhongjing Museum, Ningcheng county, Inner Mongolia Date (AD) : late Published : Zhongguo taoci quanji bianji weiyuanhui 1999, pl. 118.</p>	 <p>Cat. 506</p>
<p>Catalogue No. : Cat. 507 Type : Dc Body : porcelain Glaze : white Decoration : In form of a dragon-fish Size (cm) : Height: 14.7 Unearthed From : Collected By : Tokyo National Museum Date (AD) : Published : Mok 1985, pl. 18.</p>	 <p>Cat. 507</p>
<p>Catalogue No. : Cat. 508 Type : Dc Body : Pinkish earthenware Glaze : Three-colored Decoration : In form of a dragon-fish with Moulded designs Size (cm) : Height: 14.3. Unearthed From : Collected By : The Palace Museum, Beijing Date (AD) : Published : Feng Yongqian 1981c, 65-71, fig.3.</p>	 <p>Cat. 508</p>
<p>Catalogue No. : Cat. 509 Type : Dd Body : Pinkish earthenware Glaze : Three-colored Decoration : In form of a mandarin duck with Moulded designs Size (cm) : Height: 16.5.. Unearthed From : A tomb at Wangjiadian, Chifeng, Inner Mongolia Collected By : Chifeng municipal museum, Inner Mongolia Date (AD) : late Published : Xiang Chunsong 1991, 33-9, fig.4:left.</p>	 <p>Cat. 509</p>

<p>Catalogue No. : Cat. 510 Type : Dd Body : Pinkish earthenware Glaze : Three-colored Decoration : In form of a mandarin duck with Moulded designs Size (cm) : Height: 20; Diameter of mouth: 8.2; Diameter of base: 9. Unearthed From : A tomb at Wangjiayingzi, Songshan district, Chifeng, Inner Mongolia Collected By : Chifeng municipal museum, Inner Mongolia Date (AD) : late Published : Zhongguo taoci quanji bianji weiyuanhui 1999, pl.133; Neimenggu zizhiqiu wenhuating & Zhongguo lishi bowuguan 2002, pl. 285; Shanghai bowuguan 2000, pl. 184; Feng Yongqian 1981c, 65-71, fig.25.</p>	 <p>Cat. 510</p>
<p>Catalogue No. : Cat. 511 Type : Dd Body : Pinkish earthenware Glaze : Three-colored Decoration : In form of a mandarin duck with Moulded designs Size (cm) : Height: 19.4; Length: 23.7. Unearthed From : A tomb at Yihefang of Lingyuan county, Liaoning Collected By : Liaoning Provincial museum Date (AD) : late Published : Shanghai renmin meishu chubanshe ed. Pl. 38.</p>	 <p>Cat. 511</p>
<p>Catalogue No. : Cat. 512 Type : De Body : Buff stoneware Glaze : green Decoration : In the form of parrot Size (cm) : Height: 19.5; Diameter of base: 8.9. Unearthed From : A tomb at Tuchengzi site, Helinge'er county, Huhhot City, Inner Mongolia Collected By : Inner Mongolia Autonomous Region Museum Date (AD) : early Published : Mok 1985, pl. 143; Zhonghua shiji tan & Neimenggu bowuguan 2004, pl. 170.</p>	 <p>Cat. 512</p>

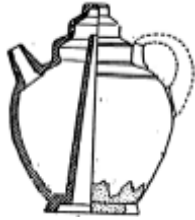

<p>Catalogue No. : Cat. 513 Type : De Body : Buff stoneware Glaze : white Decoration : In the form of parrot Size (cm) : Height: 25. Unearthed From : Collected By : Xiwenguozhai collection Date (AD) : Published : So 2004, pl. :2.</p>	 <p>Cat. 513</p>
<p>Catalogue No. : Cat. 514 Type : Df Body : porcelain Glaze : white Decoration : In the form of a human-headed dragon-fish Size (cm) : Height: 16. Unearthed From : A tomb at Wulantaohai, Bailin Left Banner, Inner Mongolia Collected By : Relics office of Chifeng city, Inner Mongolia Date (AD) : Published : Zhongguo taoci quanji bianji weiyuanhui 1999, pl. 44; Zeng Yu 1984, pl. 33-36, fig. 11.</p>	  <p>Cat. 514</p>
<p>Catalogue No. : Cat. 515 Type : Df Body : porcelain Glaze : white Decoration : In the form of a human-headed dragon-fish Size (cm) : Unearthed From : Collected By : British Museum, London Date (AD) : Published :</p>	 <p>Cat. 515</p>
<p>Catalogue No. : Cat. 516 Type : Df Body : Pinkish earthenware Glaze : Three-colored Decoration : In the form of a human-headed dragon-fish Size (cm) : Height: 26.7. Unearthed From : Collected By : Sold by Sotheby's at New York on June, 1983 Date (AD) : late Published : Mok 1985, pl. 22.</p>	 <p>Cat. 516</p>

<p>Catalogue No. : Cat. 517 Type : Dg Body : Pinkish earthenware Glaze : Three-colored Decoration : In the form of a tortoise with incised designs of leaves , vines and pomegranate Size (cm) : Height: 11; Length: 25.. Unearthed From : A tomb at Yushulinzi, Ningcheng county, Inner Mongolia Collected By : Ningcheng Museum, Inner Mongolia Date (AD) : late Published : Neimenggu zizhi qu wenhua ting & Zhongguo lishi bowuguan 2002, pl. 289; Feng Yongqian 1981c, 65-71, fig.22.</p>	 <p>Cat. 517</p>
<p>Catalogue No. : Cat. 518 Type : Dh Body : Pinkish earthenware Glaze : Three-colored Decoration : Moulded designs Size (cm) : Height: 21; Diameter of belly: 18.6-13.2; Diameter of mouth: 3.7; Diameter of base: 10.8-8.9. Unearthed From : Collected By : Liaoning Provincial Museum Date (AD) : late Published : Zhongguo taoci quanji bianji weiyuanhui 1999 pl. 119; Shanghai renmin meishu chubanshe ed. 1986, pl. 88; Liaoningsheng bowuguan 1961, pl. 5.</p>	 <p>Cat. 518</p>
<p>Catalogue No. : Cat. 519 Type : Dh Body : Pinkish earthenware Glaze : Three-colored Decoration : Moulded phoenix designs Size (cm) : Height: 18; Diameter of mouth: 5.6; Diameter of base: 6.5. Unearthed From : A tomb at Changsheng Township, Aohan Banner, Inner Mongolia Collected By : Aohan Banner Museum, Inner Mongolia Date (AD) : late Published : Shao Guotian ed. 2004, pl. 127-1.</p>	 <p>Cat. 519</p>

<p>Catalogue No. : Cat. 520 Type : Di Body : Pinkish earthenware Glaze : Three-colored Decoration : In the form of fish with moulded designs Size (cm) : Height: 15; Diameter of mouth: 5; Diameter of base: 7. Unearthed From : Collected By : The Palace Museum, Beijing Date (AD) : late Published : Zhongguo taoci quanji bianji weiyuanhui 1999, pl. 104.</p>	 <p>Cat. 520</p>
<p>Catalogue No. : Cat. 521 Type : Dj Body : Pinkish earthenware Glaze : Three-colored Decoration : In the form of a bird Size (cm) : Height: 9.9; Length: 17. Unearthed From : Collected By : Royal Ontario Museum, Toronto Date (AD) : late Published : Mino Yutaka et al. 1973, pl. 54.</p>	 <p>Cat. 521</p>
<p>Catalogue No. : Cat. 522 Type : Dk Body : porcelain Glaze : white Decoration : In the form of dragon-fish Size (cm) : Height: 12; Length: 14.5. Unearthed From : A tomb at Kulun Banner, Inner Mongolia Collected By : Zhelimu leagure Museum, Inner Mongolia Date (AD) : Published : Lu Jing 2003, pl. 3-222; Sun Ji 1986, 74-8, fig.1:1.</p>	 <p>Cat. 522</p>
<p>Catalogue No. : Cat. 523 Type : Dl Body : porcelain Glaze : white Decoration : In the form of dragon-fish Size (cm) : Length: 20.6. Unearthed From : Collected By : Date (AD) : Published : Mok 1985, pl. 20; Sun Ji 1986, 74-8, fig.1:2.</p>	 <p>Cat. 523</p>



<p>Catalogue No. : Cat. 524 Type : D1 Body : porcelain Glaze : white Decoration : In the form of dragon-fish Size (cm) : Length: 19.8. Unearthed From : Collected By : Guan Baocong collection Date (AD) : Published : Unpublished</p>	 <p>Cat. 524</p>
<p>Catalogue No. : Cat. 525 Type : Ea Body : Pinkish earthenware Glaze : green Decoration : With s inner tube Size (cm) : Height: 16.6. Unearthed From : GDG Collected By : Chifeng municipal museum Date (AD) : middle I Published : Xiang Chunsong 1989, 41-44, fig.1.</p>	 <p>Cat. 525</p>
<p>Catalogue No. : Cat. 526 Type : Ea Body : stoneware Glaze : white Decoration : With s inner tube Size (cm) : Height: 16; Diameter of belly: 12; Diameter of base: 5.5. Unearthed From : A tomb at Taiping village Hadayingge, Township, Balin Left Banner, Inner Mongolia Collected By : Liaoshangjing Museum, Inner Mongolia Date (AD) : Published : Tang Cailan 2005, pl. 57; Feng Yongqian 1981c, 65-71, fig.18.</p>	 <p>Cat. 526</p>





<p>Catalogue No. : Cat. 527 Type : Eb Body : stoneware Glaze : green Decoration : With a inner tube Size (cm) : Height: 21.6. Unearthed From : A tomb at Songshan, Chifeng, Inner Mongolia Collected By : Relics office of Songshan district, Chifeng city, Inner Mongolia Date (AD) : Published : Neimenggu zizhiqu wenhuating & Zhongguo lishi bowuguan 2003, pl. 272.</p>	 <p>Cat. 527</p>
<p>Catalogue No. : Cat. 528 Type : Ec Body : stoneware Glaze : yellow Decoration : With a inner tube Size (cm) : Height: 16.5 Unearthed From : Collected By : Guan Baocong collection Date (AD) : late Published : Lu Jing 2003, pl. 3-229.</p>	 <p>Cat. 528</p>
<p>Catalogue No. : Cat. 529 Type : Ed Body : stoneware Glaze : white Decoration : With black pigment painted, dragon shaped handle, a child sculpture applied on the spout. Size (cm) : Height: 28.4; Diameter of belly: 17; Diameter of base: 8.8. Unearthed From : A tomb at Baitaigou, Fuxin city, Liaoning province Collected By : Liaoning Provincial Museum Date (AD) : late Published : Tang Cailan 2005, pl. 267; Zhongguo taoci quanji bianji weiyuanhui 1999, pl. 47.</p>	 <p>Cat. 529</p>

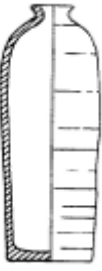

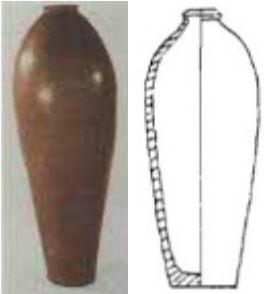

<p>Catalogue No. : Cat. 530 Type : Ee Body : stoneware Glaze : White with brown iron pigment painted Decoration : With a inner tube, in the form of a chicken, brown iron pigment painted. Size (cm) : Height: 18; Diameter of belly: 12-14; Diameter of base 7.5. Unearthed From : Collected By : Liaoning Provincial Museum Date (AD) : late Published by : Xu Bingkun & Sun Shoudao ed. 1998, pl.242; Zhongguo taoci quanji bianji weiyuanhui 1999, pl.48; Liaoningsheng bowuguan 1961, pl. 25; Shanghai remin meishu chubanshe 1986, pl.44.</p>	 <p>Cat. 530</p>
<p>Catalogue No. : Cat. 531 Type : E Body : stoneware Glaze : white Decoration : Inner tube Size (cm) : Unearthed From : GGT kiln site, Liaoning Collected By : Guan Baocong collection Date (AD) : late Published : Lu Jing 2003, pl. 3-227.</p>	 <p>Cat. 531</p>



3.9 CHICKEN-LEG VASE





<p>Catalogue No. : Cat. 532 Type : A Body : stoneware Glaze : black Decoration : Size (cm) : Height: 31.2 Unearthed From : HLDT2 Collected By : Date (AD) : early Published : Zhang Shaoqing 1988, 819-24, fig.7:1.</p>	 <p>Cat. 532</p>
--	--

<p>Catalogue No. : Cat. 533 Type : A Body : stoneware Glaze : Tea-dust green Decoration : Size (cm) : Height: 45. Unearthed From : SQ1 Collected By : Liaoning provincial museum Date (AD) : middle Published : Xu Yulin 1977, 44-51, fig. 23:2.</p>	 <p>Cat. 533</p>
<p>Catalogue No. : Cat. 534 Type : A Body : stoneware Glaze : Tea-dust green Decoration : Size (cm) : Height: 44.5; Diameter of mouth: 7.4; Diameter of belly: 18; Diameter of base: 15.5. Unearthed From : YMT22 Collected By : Date (AD) : middle Published : Xu Zhiguo & Wei Chunguang 2000, 48-51, fig.3:4.</p>	 <p>Cat. 534</p>
<p>Catalogue No. : Cat. 535 Type : A Body : stoneware Glaze : Tea-dust green Decoration : Size (cm) : Height: 48. Unearthed From : HYM Collected By : Date (AD) : 1011 Published : Huang Xiuchun et al. 1984, 361-81.</p>	 <p>Cat. 535</p>
<p>Catalogue No. : Cat. 536 Type : A Body : stoneware Glaze : Tea-dust green Decoration : Size (cm) : Height:33; Diameter of mouth: 6.5; Diameter of belly: 18; Diameter of base: 14. Unearthed From : WDGM Collected By : Date (AD) : late Published : Zhang Hanying 1996, 18-25, fig.1:1.</p>	 <p>Cat. 536</p>

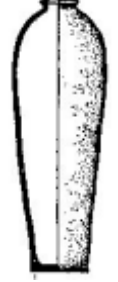

<p>Catalogue No. : Cat. 537 Type : B Body : stoneware Glaze : Tea-dust green Decoration : Size (cm) : Height: 49. Unearthed From : YMT7 Collected By : Liaoning provincial museum Date (AD) : 977 Published : Liaoningsheng bowuguan et al. 1975, 26-36; Feng Yongqian 1975, 40-48, fig.4:3.</p>	 <p>Cat. 537</p>
<p>Catalogue No. : Cat. 538 Type : B Body : stoneware Glaze : Tea-dust green Decoration : Size (cm) : Height: 47; Diameter of mouth: 7. Unearthed From : a tomb at Xishan of Yemaotai, Faku County, Liaoning province Collected By : Liaoning Tieling qunzhongyishuguan wenwuzu Date (AD) : middle II Published : Shanghai renmin meishu chubanshe ed. 1986, pl. 92.</p>	 <p>Cat. 538</p>
<p>Catalogue No. : Cat. 539 Type : B Body : stoneware Glaze : Tea-dust green Decoration : Size (cm) : Height: 52. Unearthed From : BL1 Collected By : Liaoning provincial museum Date (AD) : Middle Published : Wu Jiachang 1986, 32-51, fig.4:6.</p>	 <p>Cat. 539</p>
<p>Catalogue No. : Cat. 540 Type : B Body : stoneware Glaze : Tea-dust green Decoration : Size (cm) : Height: 54.8. Unearthed From : CGGZ Collected By : Inner Mongolia cultural relics and Archaeology institute Date (AD) : 1018 Published : Neimenggu wenwu kaogu yanjiusuo et al. 1993, 53, fig.32:2; Neimenggu zizhiqu wenhuating & Zhongguo lishi bowuguan 2002, pl.268.</p>	 <p>Cat. 540</p>





<p>Catalogue No. : Cat. 541 Type : B Body : stoneware Glaze : Tea-dust green Decoration : Size (cm) : Height: 48.2; Diameter of mouth: 7.4; Diameter of belly: 18.5; Diameter of base: 12.3. Unearthed From : YMT22 Collected By : Date (AD) : middle Published : Xu Zhiguo & Wei Chunguang 2000, 48-51, fig.3:5.</p>	 <p>Cat. 541</p>
<p>Catalogue No. : Cat. 542 Type : B Body : stoneware Glaze : Tea-dust green Decoration : Size (cm) : Height: 48.5; Diameter of mouth: 6.5-7.5; Diameter of base: 10.4. Unearthed From : CYG3 Collected By : Zhangwushi wenwu guanlisuo Date (AD) : middle Published : Li Yufeng et al. 2003, 83-111, fig.32:2.</p>	 <p>Cat. 542</p>
<p>Catalogue No. : Cat. 543 Type : B Body : stoneware Glaze : Tea-dust green Decoration : Size (cm) : Height: 51. Unearthed From : SQ1 Collected By : Liaoning provincial museum Date (AD) : middle Published : Xu Yulin 1977, 44-51, fig. 23:3.</p>	 <p>Cat. 543</p>
<p>Catalogue No. : Cat. 544 Type : B Body : stoneware Glaze : Tea-dust green Decoration : Size (cm) : Height: 53.8. Unearthed From : QHM4 Collected By : Liaoning provincial museum Date (AD) : 1032-1064 Published : Li Wenxin 1954, 163-202, fig.22:3.</p>	 <p>Cat. 544</p>

<p>Catalogue No. : Cat. 545 Type : B Body : stoneware Glaze : Black Decoration : Size (cm) : Height: 46. Unearthed From : Collected By : Nelson-Atkins Gallery, Kansas city, Missouri Date (AD) : middle Published : Mino Yutaka et al. 1973, pl. 34.</p>	 <p>Cat. 545</p>
<p>Catalogue No. : Cat. 546 Type : B Body : stoneware Glaze : Black Decoration : Size (cm) : Height: 52; Diameter of mouth: 7.2; Diameter of base: 13.5. Unearthed From : Collected By : Guan Baocong collection Date (AD) : middle Published : Lu Jing 2003, pl. 4-108.</p>	 <p>Cat. 546</p>
<p>Catalogue No. : Cat. 547 Type : B Body : stoneware Glaze : Tea-dust green Decoration : Size (cm) : Height: 50.5. Unearthed From : QHZ Collected By : Date (AD) : late Published : Fu Zhanjun 1990, 49-51, fig.2:3.</p>	 <p>Cat. 547</p>
<p>Catalogue No. : Cat. 548 Type : B Body : stoneware Glaze : Tea-dust green Decoration : Size (cm) : Height: 50. Unearthed From : QHZ Collected By : Date (AD) : late Published : Fu Zhanjun 1990, 49-51, fig.2:4.</p>	 <p>Cat. 548</p>

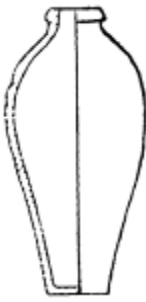

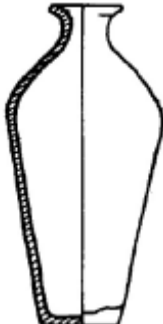

<p>Catalogue No. : Cat. 549 Type : B Body : stoneware Glaze : Tea-dust green Decoration : Size (cm) : Height: 52.5 Unearthed From : GS1 Collected By : Date (AD) : late Published : Jin Fengyi & Xu Ji 1985, 48-55, fig.7:5.</p>	 <p>Cat. 549</p>
<p>Catalogue No. : Cat. 550 Type : B Body : stoneware Glaze : Tea-dust green Decoration : Size (cm) : Height: 51.6 Unearthed From : MTYZ1 Collected By : Date (AD) : late Published : Zheng Long 1981, 231-43.</p>	 <p>Cat. 550</p>
<p>Catalogue No. : Cat. 551 Type : B Body : stoneware Glaze : Tea-dust green Decoration : Inscription on the shoulder "Qian er nian Tian" Size (cm) : Height: 64.9; Diameter of belly: 24.3; Diameter of mouth: 8.4. Unearthed From : Collected By : Liaoning provincial museum Date (AD) : 1102 Published : Zhongguo taoci quanji bianji weiyuanhui 1999, pl. 60.</p>	 <p>Cat. 551</p>
<p>Catalogue No. : Cat. 552 Type : B Body : stoneware Glaze : Tea-dust green Decoration : Size (cm) : Height: 69.5. Unearthed From : Collected By : Royal Ontario Museum, Toronto Date (AD) : late Published : Mino Yutaka et al. 1973, pl.32.</p>	 <p>Cat. 552</p>



<p>Catalogue No. : Cat. 553 Type : B Body : stoneware Glaze : Tea-dust green Decoration : Inscription on the shoulder Size (cm) : Height: 67; Diameter of mouth: 9.5; Diameter of base: 13. Unearthed From : a tomb at Shuangjing township, Aohan Banner, Inner Mongolia Collected By : Aohan Banner Museum, Inner Mongolia Date (AD) : 1101-1110 Published : Shao Guotian ed. 2004, pl. 140.</p>	 <p>Cat. 553</p>
<p>Catalogue No. : Cat. 554 Type : B Body : stoneware Glaze : Tea-dust green Decoration : Inscription on the shoulder Size (cm) : Height: 69; Diameter of mouth: 6; Diameter of base: 13. Unearthed From : a tomb at Shanwan village, Biliutai township, Balin Left Banner, Inner Mongolia Collected By : Liaoshangjing museum, Inner Mongolia Date (AD) : 1101-1110 Published : Tang Cailan 2005, pl. 56; Shen Hsuen-man 2006, pl. 42.</p>	 <p>Cat. 554</p>
<p>Catalogue No. : Cat. 555 Type : B Body : stoneware Glaze : Tea-dust green Decoration : Inscription on the shoulder Size (cm) : Height: 68.8; Diameter of mouth: 10.2; Diameter of belly: 21; Diameter of base: 12.6. Unearthed From : Collected By : Liaoning provincial museum Date (AD) : 1101-1110 Published : Liaoningsheng bowuguan 1961, pl. 64.</p>	 <p>Cat. 555</p>
<p>Catalogue No. : Cat. 556 Type : B Body : stoneware Glaze : Black Decoration : Inscription on the shoulder Size (cm) : Height: 64.2; Diameter of mouth: 9.8. Unearthed From : Collected By : Liaoning provincial museum Date (AD) : 1101-1110 Published : Shanghai renmin meishu chubanshe ed. 1986, pl. 86.</p>	 <p>Cat. 556</p>



<p>Catalogue No. : Cat. 557 Type : B Body : stoneware Glaze : Tea-dust green Decoration : Size (cm) : Height: 64.8. Unearthed From : Collected By : Royal Ontario Museum, Toronto Date (AD) : late Published : Mino Yutaka et al. 1973, pl.33.</p>	 <p>Cat. 557</p>
<p>Catalogue No. : Cat. 558 Type : B Body : stoneware Glaze : Black Decoration : Size (cm) : Height: 48.7 Unearthed From : Collected By : Japanese collection Date (AD) : late Published : Sugimura Yuzo 1974, pl. 85.</p>	 <p>Cat. 558</p>
<p>Catalogue No. : Cat. 559 Type : B Body : stoneware Glaze : Tea-dust green Decoration : Size (cm) : Height: 28.5. Unearthed From : ZGY Collected By : Date (AD) : 1117 Published : Tao Zongyi 1990, 1-19, fig.10:6.</p>	 <p>Cat. 559</p>
<p>Catalogue No. : Cat. 560 Type : B Body : stoneware Glaze : Tea-dust green Decoration : Size (cm) : Height: 21 Unearthed From : ZWZ(M7:21) Collected By : Date (AD) : 1093 Published : Zheng Shaozong 1996, 14-46, fig.32:12.</p>	 <p>Cat. 560</p>



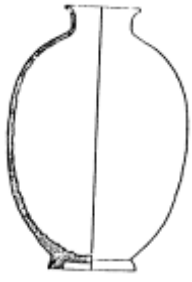

<p>Catalogue No. : Cat. 561 Type : A Body : stoneware Glaze : Black Decoration : Size (cm) : Height: 33.6; Diameter of mouth: 4.6; Diameter of base: 7.8. Unearthed From : CGM Collected By : Date (AD) : Late Published : Tao Min 2003, 50-51.</p>	 <p>Cat. 561</p>
<p>Catalogue No. : Cat. 562 Type : A Body : stoneware Glaze : Tea-dust green Decoration : Size (cm) : Height: 40.2. Unearthed From : Collected By : Japanese collection Date (AD) : Published : Sugimura Yuzo 1974, pl.32.</p>	 <p>Cat. 562</p>
<p>Catalogue No. : Cat. 563 Type : B Body : stoneware Glaze : Tea-dust green Decoration : Size (cm) : Height: 28; Diameter of mouth: 5.4; Diameter of base: 8. Unearthed From : XHD Collected By : Date (AD) : middle Published : Wang Gang 1998, 44-9, fig.3:1..</p>	 <p>Cat. 563</p>
<p>Catalogue No. : Cat. 564 Type : B Body : stoneware Glaze : Tea-dust green Decoration : Size (cm) : Height: 36; Diameter of mouth: 7. Unearthed From : Collected By : Liaoning provincial museum Date (AD) : late Published : Shanghai renmin meishu chubanshe ed. 1986, pl. 41; Liaoningsheng bowuguan 1961, pl. 65.</p>	 <p>Cat. 564</p>

3.10 CHINESE STYLE VASES

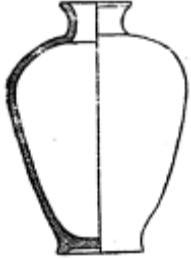
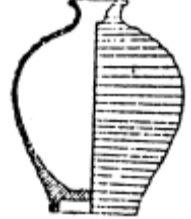



<p>Catalogue No. : Cat. 565 Type : A Body : Stoneware Glaze : brown Decoration : Size (cm) : Height: 27.5. Unearthed From : YMT7 Collected By : Liaoning Provincial Museum Date (AD) : 977 Published by : Liaoningsheng bowuguan et al. 1975, 26-36; Liaoningsheng bowuguan 1961, pl. 50; Feng Yongqian 1975, 40-8, fig.5:1.</p>	 <p>Cat. 565</p>
<p>Catalogue No. : Cat. 566 Type : A Body : Stoneware Glaze : black Decoration : Size (cm) : Height: 40.4. Unearthed From : QHM4 Collected By : Liaoning Provincial Museum Date (AD) : middle Published by : Li Wenxin 1954, 163-202, fig.23:5; Shanghai renmin meishu chubanshe 1986, pl. 98.</p>	 <p>Cat. 566</p>
<p>Catalogue No. : Cat. 567 Type : A Body : Stoneware Glaze : brown Decoration : Size (cm) : Height: 43.3.. Unearthed From : YMT3 Collected By : Date (AD) : late Published by :Feng Yongqian 1994a, 163-90, fig.6:2.</p>	 <p>Cat. 567</p>
<p>Catalogue No. : Cat. 568 Type : A Body : stoneware Glaze : Tea-dust green Decoration : Guan inscription on the shoulder Size (cm) : Height: 47; Diameter of mouth: 7; Diameter of base: 12. Unearthed From : Collected By : Guan Baocong collection Date (AD) : late Published : Lu Jing 2003, pl.4-107-1.</p>	 <p>Cat. 568</p>

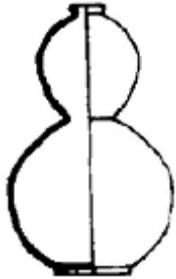

<p>Catalogue No. : Cat. 569 Type : A Body : Stoneware Glaze : white Decoration : Size (cm) : Height: 32. Unearthed From : KL1 Collected By : Date (AD) : 1080 Published by : Wang Jianqun & Chen Xiangwei 1989, 12, fig.7.</p>	 <p>Cat. 569</p>
<p>Catalogue No. : Cat. 570 Type : A Body : Stoneware Glaze : white Decoration : Incised peony scroll band with black painted on the ground. Incised lotus pedals on under this band Size (cm) : Height: 42.5; Diameter of mouth: 7.3. Unearthed From : Collected By : The Capital Museum, Beijing Date (AD) : late Published by : Zhongguo taoci quanji bianji weiyuanhui 1999, pl. 54; Shoudu bowuguan 1991, pl.41.</p>	 <p>Cat. 570</p>
<p>Catalogue No. : Cat. 571 Type : A Body : Stoneware Glaze : white Decoration : Incised peony scroll band with black painted on the ground. Incised lotus pedals on under this band Size (cm) : Height: 36.7; Diameter of belly: 16.2. Unearthed From : Collected By : Liaoning Provincial Museum Date (AD) : late Published by : Liaoningsheng bowuguan 1983; Shanghai renmin meishu chubanshe 1986, pl. 130; Liaoningsheng bowuguan 1961, pl. 58.</p>	 <p>Cat. 571</p>

<p>Catalogue No. : Cat. 572 Type : A Body : Stoneware Glaze : white Decoration : Incised peony scroll designs. Size (cm) : Height: 39.3; Diameter of mouth: 6.9. Unearthed From : Collected By : Liaoning Provincial Museum Date (AD) : late Published by : Zhongguo taoci quanji bianji weiyuanhui 1999, pl. 10; Liaoningsheng bowuguan 1961, pl. 57.</p>	 <p>Cat. 572</p>
<p>Catalogue No. : Cat. 573 Type : A Body : Stoneware Glaze : white Decoration : Incised peony scroll designs. Size (cm) : Height: 29; Diameter of mouth: 5. Unearthed From : Collected By : Datong Municipal Museum, Shanxi Province Date (AD) : late Published by : Zhongguo taoci quanji bianji weiyuanhui 1999, pl. 24.</p>	 <p>Cat. 573</p>
<p>Catalogue No. : Cat. 574 Type : B Body : Porcelain Glaze : white Decoration : Size (cm) : Height: 19.8. Unearthed From : QHM2 Collected By : Date (AD) : 1057 Published by : Li Wenxin 1954, 163-202, fig. 10:2.</p>	 <p>Cat. 574</p>
<p>Catalogue No. : Cat. 575 Type : B Body : Porcelain Glaze : white Decoration : horizontally fluted Size (cm) : Height: 14. Unearthed From : KL1 Collected By : Date (AD) : 1080 Published by : Wang Jianqun & Chen Xiangwei 1989; Chen Xiangwei & Wang Jianqun 1973, 2-18, fig.6:8.</p>	 <p>Cat. 575</p>



<p>Catalogue No. : Cat. 576 Type : B Body : Porcelain Glaze : white Decoration : Size (cm) : Height: 23.2; Diameter of mouth: 5.6; Diameter of base: 8.6. Unearthed From : CDMM Collected By : Date (AD) : late Published by : Wang Laizhu, 1996, 66-68, fig.3:3.</p>	 <p>Cat. 576</p>
<p>Catalogue No. : Cat. 577 Type : B Body : Porcelain Glaze : white Decoration : Size (cm) : Height: 22.4; Diameter of mouth: 6.4; Diameter of base: 6.8. Unearthed From : Tomb at Majiagou, Lingyuan County, Liaoning Province Collected By : Date (AD) : late Published by : Lü Xueming & Zhu Da 2003, 134-41, fig.7:6.</p>	 <p>Cat. 577</p>
<p>Catalogue No. : Cat. 578 Type : B Body : Porcelain Glaze : white Decoration : Decorated with black painted floral designs on the belly. Size (cm) : Height: 30.3; Diameter of mouth: 8.6; Diameter of belly: 22.5; Diameter of base: 10.1. Unearthed From : A tomb at Wushijiazi, Machang Township, Jianping County, Liaoning Province Collected By : Liaoning Provincial Museum Date (AD) : late Published by : Zhongguo taoci quanji bianji weiyuanhui 1999, pl. 50; Liaoningsheng bowuguan 1961, pl. 54.</p>	 <p>Cat. 578</p>
<p>Catalogue No. : Cat. 579 Type : B Body : Porcelain Glaze : white Decoration : Size (cm) : Height: 22.5; Diameter of mouth: 6.2; Diameter of base: 7.4. Unearthed From : Tomb at Yaojiagou, Jinchanggouliang Township, Aohan Banner, Inner Mongolia Collected By : Aohan Banner Museum, Inner Mongolia Date (AD) : Late Published by : Shao Guotian ed. 2004, pl. 146-1.</p>	 <p>Cat. 579</p>

<p>Catalogue No. : Cat. 580 Type : B Body : Stoneware Glaze : brown Decoration : Size (cm) : Height: 25; Diameter of mouth: 6.4; Diameter of base: 8.8. Unearthed From : A tomb at Shakengzi, Mutouyingzi Township, Aohan Banner, Inner Mongolia Collected By : Aohan Banner Museum, Inner Mongolia Date (AD) : late Published by : Shao Guotian ed. 2004, pl. 150.</p>	 <p>Cat. 580</p>
<p>Catalogue No. : Cat. 581 Type : B Body : Porcelain Glaze : white Decoration : Size (cm) : Height: 22; Diameter of mouth: 3.8. Unearthed From : Collected By : Guan Baocong collection Date (AD) : late Published by : Lu Jing 2003, pl. 3-320.</p>	 <p>Cat. 581</p>
<p>Catalogue No. : Cat. 582 Type : B Body : Stoneware Glaze : black Decoration : Incised Chinese character "Zhao" inscription on the bottom Size (cm) : Height: 19; Diameter of mouth: 5.7; Diameter of base: 7.7. Unearthed From : Collected By : Guan Baocong collection Date (AD) : late Published by : Lu Jing 2003, pl. 4-111.</p>	 <p>Cat. 582</p>
<p>Catalogue No. : Cat. 583 Type : C Body : Porcelain Glaze : white Decoration : Size (cm) : Height: 21. Unearthed From : HQY9 Collected By : Date (AD) : late Published by : Wumeng wenwu gongzuozhan & Neimenggu wenwu gongzuodui 1985, 45-71, fig.12:1.</p>	 <p>Cat. 583</p>

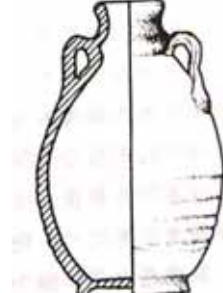
<p>Catalogue No. : Cat. 584 Type : C Body : unknown Glaze : unknown Decoration : Size (cm) : unknown Unearthed From : SHZC Collected By : Date (AD) : late Published by : Xin Jian & Cui Fulai 1991, 30-31.</p>	 <p>Cat. 584</p>
<p>Catalogue No. : Cat. 585 Type : C Body : Stoneware Glaze : black Decoration : Brown Painted floral designs. Size (cm) : Height: 35.8; Diameter of mouth: 2.8; Diameter of base: 9.4. Unearthed From : A tomb at Hurenbaohe village, Xinhui Township, Aohan Banner, Inner Mongolia. Collected By : Aohan Banner Museum, Inner Mongolia Date (AD) : late Published by : Shao Guotian ed. 2004, pl. 124; Zhongguo taoci quanji bianji weiyuanhui 1999, pl. 59; Neimenggu zizhiqiu wenhuating & Zhongguo lishi bowuguan 2002, pl. 238; Shanhai bowuguan 2000, pl. 179; Shao Guotian 1997, 41, fig.1.</p>	 <p>Cat. 585</p>
<p>Catalogue No. : Cat. 586 Type : C Body : Stoneware Glaze : white Decoration : Size (cm) : Height: 29.4; Diameter of mouth: 4.8; Diameter of base: 8.7. Unearthed From : A tomb at Yezhushan, Mutouyingzi Township, Aohan Banner, Inner Mongolia Collected By : Aohan Banner Museum Date (AD) : late Published by : Shao Guotian ed. 2004, pl. 133.</p>	 <p>Cat. 586</p>
<p>Catalogue No. : Cat. 587 Type : C Body : Porcelain Glaze : white Decoration : Carved lotus petals designs Size (cm) : Height: 19. Unearthed From : Collected By : Guan Baocong collection Date (AD) : Photo by : Lu Jing</p>	 <p>Cat. 587</p>

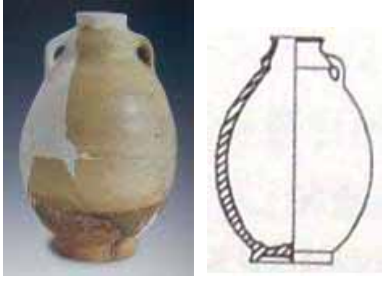
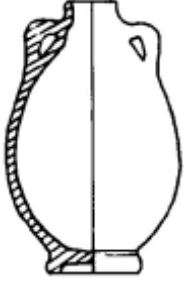
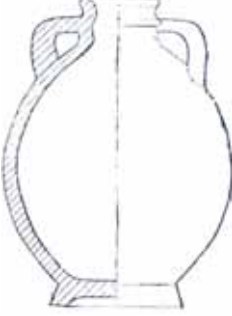
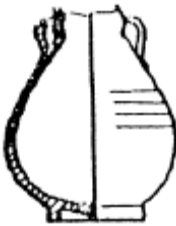
<p>Catalogue No. : Cat. 588 Type : C Body : Stoneware Glaze : white Decoration : Size (cm) : Height: 23; Diameter of mouth: 2.5; Diameter of base: 6.5. Unearthed From : Collected By : Guan Baocong collection Date (AD) : late Published by : Lu Jing 2003, pl. 4-70.</p>	 <p>Cat. 588</p>
<p>Catalogue No. : Cat. 589 Type : C Body : Stoneware Glaze : white Decoration : Size (cm) : 24.5 Unearthed From : A tomb at Haoxiumaodu in Zhagesitai Township, Aluke'erqin Banner, Inner Mongolia Collected By : Date (AD) : late Published by : Feng Yongqian 1981c, 65-71, fig. 16.</p>	 <p>Cat. 589</p>
<p>Catalogue No. : Cat. 590 Type : C Body : Earthenware Glaze : yellow Decoration : Size (cm) : Height: 22; Diameter of mouth: 1.9; Diameter of base: 7.5. Unearthed From : Collected By : Guan Baocong collection Date (AD) : late Published by : Lu Jing 2003, pl. 4-141.</p>	 <p>Cat. 590</p>
<p>Catalogue No. : Cat. 591 Type : D Body : stoneware Glaze : white Decoration : Size (cm) : Height: 15; Diameter of mouth: 3.3; Diameter of base: 5.8. Unearthed From : Tomb at Chaoyanggou, Zhangwu City, Liaoning province Collected By : Relics office of Zhangwu, Liaoning Date (AD) : late Published by : Li Yufeng et al. 2003, 83-111, fig.35.</p>	 <p>Cat. 591</p>

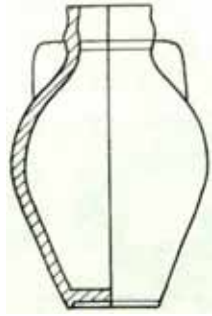



<p>Catalogue No. : Cat. 592 Type : D Body : stoneware Glaze : white Decoration : Size (cm) : Height: 14.4; Diameter of mouth: 3; Diameter of base: 5.2. Unearthed From : tomb of Xiao He at Fuxin, Liaoning Collected By : Research Institute o Cultral relics and Archaeology of Liaoning province Date (AD) : late Published by : Wan Xiongfei 2005, 33-44, fig.10:3, fig.20.</p>	 <p>Cat. 592</p>
<p>Catalogue No. : Cat. 593 Type : D Body : stoneware Glaze : white Decoration : Size (cm) : Height: 14.4; Diameter of mouth: 2.7; Diameter of base: 5. Unearthed From : FJTGD Collected By : Relics office of A Luke'erqin Banner, Inner Mongolia Date (AD) : late Published by : A Luke'erqin qi wenguan suo et al. 1996, 78-81, fig.6.</p>	 <p>Cat. 593</p>
<p>Catalogue No. : Cat. 594 Type : D Body : Stoneware Glaze : brown Decoration : Size (cm) : Height: 14. Unearthed From : HQY8 Collected By : Date (AD) : Late Published by : Wumeng wenwu gongzuozhan & Neimenggu wenwu gongzuodui 1985, 45-71, fig.13:2.</p>	 <p>Cat. 594</p>
<p>Catalogue No. : Cat. 595 Type : D Body : Stoneware Glaze : brown Decoration : Size (cm) : Height: 14. Unearthed From : PJG3 Collected By : Date (AD) : late Published by : Ji Ping 1997, 639-50, fig. 8:4.</p>	 <p>Cat. 595</p>



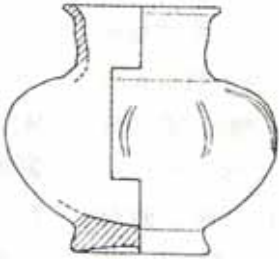
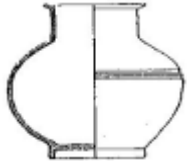
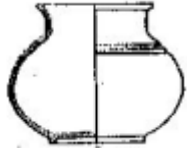
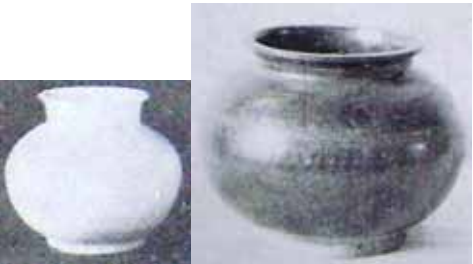

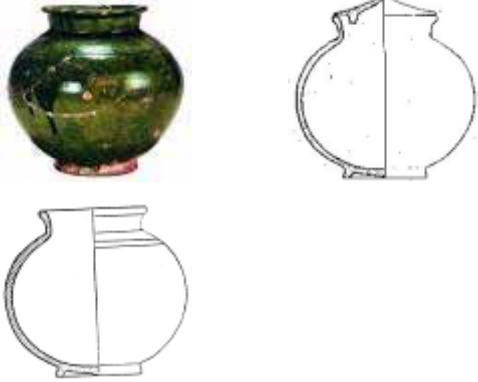
<p>Catalogue No. : Cat. 596 Type : D Body : stoneware Glaze : white Decoration : Size (cm) : Height: 15.1; Diameter of mouth: 3.7. Unearthed From : GSZ1 Collected By : Date (AD) : late Published by : Yang Dongxin 2001, 87-88, fig.2:1.</p>	 <p>Cat. 596</p>
<p>Catalogue No. : Cat. 597 Type : D Body : stoneware Glaze : white Decoration : Size (cm) : Height: 13. Unearthed From : Collected By : Guan Baocong collection Date (AD) : late Published by : Lu Jing 2003, pl. 3-342.</p>	 <p>Cat. 597</p>
<p>Catalogue No. : Cat. 598 Type : D Body : stoneware Glaze : black Decoration : Size (cm) : Height: 13.8. Unearthed From : Collected By : Guan Baocong collection Date (AD) : late Published by : Lu Jing 2003, pl. 4-104.</p>	 <p>Cat. 598</p>

3.11 JAR



<p>Catalogue No. : Cat. 599 Type : Aa Body : Buff stoneware Glaze : green Decoration : Size (cm) : Height: 8. Unearthed From : HLB1 Collected By : Date (AD) : early Published by: Li Yufeng 1991, 106-119, fig.3:4.</p>	 <p>Cat. 599</p>
---	--





<p>Catalogue No. : Cat. 600 Type : Aa Body : Buff stoneware Glaze : brown Decoration : Size (cm) : Height: 10; Diameter of mouth: 6.5; Diameter of base: 5.5. Unearthed From : Tomb at Chaoyanggou, Zhangwu city, Liaoning Province Collected By : Zhangwu municipal relics office Date (AD) : early Published by: Li Yufeng et al. 2003, 83-111, fig.26:5.</p>	 <p>Cat. 600</p>
<p>Catalogue No. : Cat. 601 Type : Aa Body : Buff stoneware Glaze : green Decoration : Size (cm) : Height: 16.9. Unearthed From : DQTL3 Collected By : Date (AD) : early Published by: Meng Jianren & Piao Chunyue 1997, 651-67, fig. 6:2.</p>	 <p>Cat. 601</p>
<p>Catalogue No. : Cat. 602 Type : Aa Body : Buff stoneware Glaze : green Decoration : Size (cm) : Height: 9.3. Unearthed From : DQTL3 Collected By : Date (AD) : early Published by: Meng Jianren & Piao Chunyue 1997, 651-67, fig. 6:5.</p>	 <p>Cat. 602</p>
<p>Catalogue No. : Cat. 603 Type : Aa Body : Porcelain Glaze : white/green Decoration : Size (cm) : Height: 9.8-15.9 Amount : 6 Unearthed From : FMM Collected By : Date (AD) : 959 Published by: Zheng Shaozong 1956, 1-26, fig.6:6, fig. 7:1.</p>	 <p>Cat. 603</p>



<p>Catalogue No. : Cat. 604 Type : Aa Body : Buff stoneware Glaze : green Decoration : Size (cm) : Height: 19.1; Diameter of mouth: 12.5. Unearthed From : CGGZ Collected By : Date (AD) : 1018 Published by: Neimenggu wenwu kaogu yanjiusuo et al. 1993, 53, fig.32:3; Zhongguo taoci quanji bianji weiyuanhui 1999, pl. 95.</p>	 <p>Cat. 604</p>
<p>Catalogue No. : Cat. 605 Type : Aa Body : Buff stoneware Glaze : brown Decoration : Size (cm) : Height: 15.2; Diameter of mouth: 11.7; Diameter of base: 8.5. Unearthed From : Collected By : Liaoshangjing Museum, Inner Mongolia Date (AD) : Published by: Tang Cailan 2005, pl. 58.</p>	 <p>Cat. 605</p>
<p>Catalogue No. : Cat. 606 Type : Aa Body : Pinkish earthenware Glaze : yellow Decoration : Size (cm) : Height: 17. Unearthed From : XLZZ1 Collected By : Date (AD) : late Published by: Li Yiyou 1961, 44-49, fig.8.</p>	 <p>Cat. 606</p>
<p>Catalogue No. : Cat. 607 Type : Aa Body : Pinkish earthenware Glaze : yellow Decoration : Incised peony Size (cm) : Height: 15.7; Diameter of mouth: 9.5; Diameter of belly : 13.9; Diameter of base: 7.5. Unearthed From : Collected By : Liaoning provincial museum Date (AD) : Late Published by: Liaoningsheng bowuguan 1961, pl. 61.</p>	 <p>Cat. 607</p>





<p>Catalogue No. : Cat. 608 Type : Aa Body : Pinkish earthenware Glaze : white Decoration : Incised peony Size (cm) : Height: 16.8. Unearthed From : Collected By : Privat collection Date (AD) : Late Published by: Lu Jing 2003, pl.3-351</p>	 <p>Cat. 608</p>
<p>Catalogue No. : Cat. 609 Type : Aa Body : Pinkish earthenware Glaze : yellow Decoration : Size (cm) : Height: 12 Unearthed From : ZTM Collected By : Date (AD) : Late Published by: Beijingshi wenwu shiye guanliju et al 1980, 23-27, fig.3.</p>	 <p>Cat. 609</p>
<p>Catalogue No. : Cat. 610 Type : Aa Body : Stoneware Glaze : white Decoration : Brown pigment dotted Size (cm) : Height: 14.6 Unearthed From : Collected By : Guan Baocong collection Date (AD) : Late Published by: Lu Jing 2003, pl. 3-354.</p>	 <p>Cat. 610</p>
<p>Catalogue No. : Cat. 611 Type : Aa Body : Stoneware Glaze : white Decoration : Incised vines on shoulder; wide, carved floral band with peonies covers central body. Dark brown iron glaze on ground of the peony, spray band. Size (cm) : Height: 47.1; Diameter of mouth: 24.8; Diameter of base: 22. Unearthed From : Kalaqin Banner, Chifeng City, Inner Mongolia Collected By : Inner Mongolia autonomous region museum Date (AD) : Late Published by: Zhongguo taoci quanji bianji weiyuanhui 1999, pl. 51.</p>	 <p>Cat. 611</p>

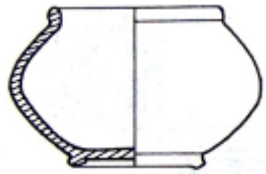
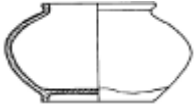

<p>Catalogue No. : Cat. 612 Type : Aa Body : Stoneware Glaze : white Decoration : Incised vines on shoulder; wide, carved floral band with peonies covers central body. Dark brown iron glaze on ground of the peony, spray band. Size (cm) : Height: 38.5; Diameter of mouth: 21. Unearthed From : Songshan District, Chifeng City, Inner Mongolia Collected By : Songshan relics office, Chifeng city, Inner Mongolia Date (AD) : Late Published by: Zhongguo taoci quanji bianji weiyuanhui 1999, pl. 53.</p>	 <p>Cat. 612</p>
<p>Catalogue No. : Cat. 613 Type : Aa Body : Stoneware Glaze : white Decoration : Incised vines on shoulder; wide, carved floral band with peonies covers central body. Dark brown iron glaze on ground of the peony, spray band. Size (cm) : Height: 32.3; Diameter of mouth: 12; Diameter of base: 11.3. Unearthed From : The Gacha site at Baoguotu Township, Aohan Banner, Inner Mongolia Collected By : Aohan Banner museum Date (AD) : Late Published by: Shao Guotian ed. 1004, pl. 147.</p>	 <p>Cat. 613</p>
<p>Catalogue No. : Cat. 614 Type : Aa Body : Stoneware Glaze : white Decoration : Incised vines on shoulder; wide, carved floral band with peonies covers central body. Dark brown iron glaze on ground of the peony, spray band. Size (cm) : Height: 35.5; Diameter of mouth: 17. Unearthed From : Collected By : Liaoning provincial museum Date (AD) : late Published by: Shanghai renmin meishu chubanshe 1986, pl. 24.</p>	 <p>Cat. 614</p>

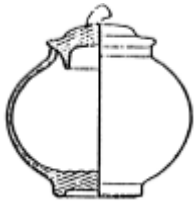

<p>Catalogue No. : Cat. 615 Type : Aa Body : Stoneware Glaze : white Decoration : Incised vines on shoulder; wide, carved floral band with peonies covers central body. Dark brown iron glaze on ground of the peony, spray band. Size (cm) : Height: 38.5; Diameter of mouth: 21. Unearthed From : Taipingchi commune of Chifeng city, Inner Mongolia Collected By : Liaoning provincial museum Date (AD) : late Published by: Shanghai renmin meishu chubanshe 1986, pl. 71.</p>	 <p>Cat. 615</p>
<p>Catalogue No. : Cat. 616 Type : Aa Body : Stoneware Glaze : white Decoration : Incised vines on shoulder; wide, carved floral band with peonies covers central body. Dark brown iron glaze on ground of the peony, spray band. Size (cm) : Height: 33.2; Diameter of belly: 32.9. Unearthed From : Collected By : Center of Asian Art and Culture, Avery Brundage Collection, San Francisco, California Date (AD) : late Published by: Mino Yutaka et al. 1973, pl. 27.</p>	 <p>Cat. 616</p>
<p>Catalogue No. : Cat. 617 Type : Aa Body : Stoneware Glaze : white Decoration : Incised vines on shoulder; wide, carved floral band with peonies covers central body. Dark brown iron glaze on ground of the peony, spray band. Size (cm) : Height: 37.5. Unearthed From : Collected By : Idemitsu Art Gallery, Tokyo Date (AD) : Published by: Mok 1985, pl. 90.</p>	 <p>Cat. 617</p>
<p>Catalogue No. : Cat. 618 Type : Aa Body : Stoneware Glaze : white Decoration : Incised vines on shoulder; wide, carved floral band with peonies covers central body. Dark brown iron glaze on ground of the peony, spray band. Size (cm) : Height: 37.1. Unearthed From : Collected By : Idemitsu Art Gallery, Tokyo Date (AD) : late Published by: Sugimura Yuzo 1974, pl. 61.</p>	 <p>Cat. 618</p>

<p>Catalogue No. : Cat. 619 Type : Aa Body : Stoneware Glaze : white Decoration : Incised vines on shoulder; wide, carved floral band with peonies covers central body. Dark brown iron glaze on ground of the peony, spray band. Size (cm) : Height: 35. Unearthed From : Liao site at Dagou Village, Nantaizi Township, Kalaqin Banner, Inner Mongolia Collected By : Date (AD) : late Published by: Feng Yongqian 1981c, 65-71, fig.2.</p>	 <p>Cat. 619</p>
<p>Catalogue No. : Cat. 620 Type : Aa Body : Stoneware Glaze : white Decoration : Incised peony scroll through white slip with dark brown iron glazed painted on the ground Size (cm) : Height: 46. Unearthed From : GWYC kiln site, Inner Mongolia Collected By : Date (AD) : late Published by: Feng Yongqian 1981c, 65-71, fig.1.</p>	 <p>Cat. 620</p>
<p>Catalogue No. : Cat. 621 Type : Aa Body : Stoneware Glaze : white Decoration : Incised peony scroll through white slip Size (cm) : Height: 35.1. Unearthed From : Collected By : Idemitsu Art Gallery, Tokyo Date (AD) : late Published by: Mok 1985, pl. 91.</p>	 <p>Cat. 621</p>
<p>Catalogue No. : Cat. 622 Type : Aa Body : Stoneware Glaze : white Decoration : Incised vines on shoulder; wide, carved floral band with peonies covers central body. Dark brown iron glaze on ground of the peony, spray band. Size (cm) : Height: 26.5; Diameter of belly: 34. Unearthed From : Collected By : Nelson-Atkins Gallery, Kansas City, Missouri Date (AD) : Late Published by: Mino Yutaka et al. 1974, pl. 28.</p>	 <p>Cat. 622</p>

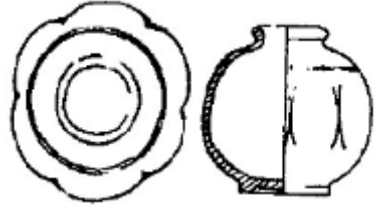

<p>Catalogue No. : Cat. 623 Type : Aa Body : Stoneware Glaze : white Decoration : Size (cm) : Height: 37; Diameter of mouth: 21; Diameter of base: 15.5. Unearthed From : Collected By : Guan Baocong collection Date (AD) : Late Published by: Lu Jing 2003, pl. 4-28.</p>	 Cat. 623
<p>Catalogue No. : Cat. 624 Type : Ab Body : Porcelain Glaze : white Decoration : Size (cm) : Height: 9.3. Unearthed From : FMM Collected By : Date (AD) : 959 Published by: Zheng Shaozong 1956, 1-26, fig.7:1(right).</p>	 Cat. 624
<p>Catalogue No. : Cat. 625 Type : Ab Body : Pinkish earthenware Glaze : white Decoration : Size (cm) : Height: 9.3. Unearthed From : HLC1 Collected By : Date (AD) : Published by: He Yong & Pang Ruixiang 1990, 21-6, fig.2:3.</p>	 Cat. 625
<p>Catalogue No. : Cat. 626 Type : Ab Body : Pinkish earthenware Glaze : green Decoration : Size (cm) : Height: 11.8, Diameter of mouthL 16.8; Diameter of base: 11.6. Unearthed From : XHD Collected By : Date (AD) : middle Published by: Wang Gang 1998, 44-9, fig.4:7.</p>	 Cat. 626

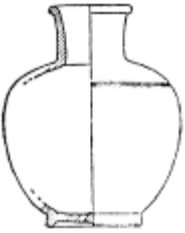
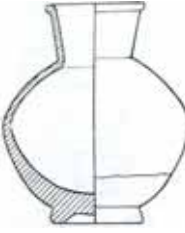
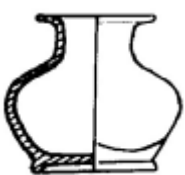

<p>Catalogue No. : Cat. 627 Type : Ab Body : Porcelain Glaze : white Decoration : Lobed belly Size (cm) : Height: 8. Unearthed From : YLYZ Collected By : Date (AD) : 942 Published by: Qi Xiaoguang et al. 1996, 4-32, fig.52; Zhongguo taoqi quanji bianji weiyuanhui 1999, pl. 22.</p>	 <p>Cat. 627</p>
<p>Catalogue No. : Cat. 628 Type : Ab Body : Porcelain Glaze : white Decoration : Lobed belly Size (cm) : Height: 11.6; Diameter of mouth: 10; Diameter of base: 8.6.. Unearthed From : Collected By : Guan Baocong collectiom Date (AD) : Published by: Lu Jing 2003, pl. 4-76.</p>	 <p>Cat. 628</p>
<p>Catalogue No. : Cat. 629 Type : Ab Body : Porcelain Glaze : white Decoration : Size (cm) : Height: 8.6. Unearthed From : HYM Collected By : Date (AD) : 997 Published by: Huang Xiuchun et al. 1984, 361-381, fig. 6:12.</p>	 <p>Cat. 629</p>
<p>Catalogue No. : Cat. 630 Type : Ab Body : Porcelain Glaze : white Decoration : Size (cm) : Height: 7. Unearthed From : GYY Collected By : Date (AD) : 1020 Published by: Zhu Zifang & Xu Ji. 1983, pl. 168-195, fig. 20:1.</p>	 <p>Cat. 630</p>



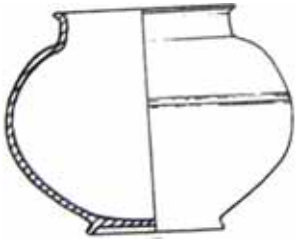
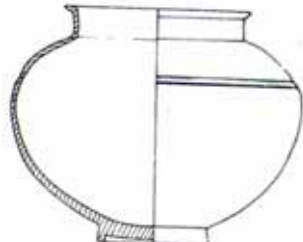
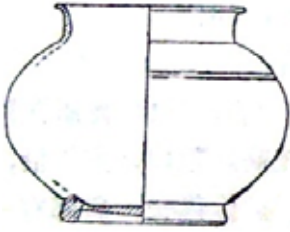

<p>Catalogue No. : Cat. 631 Type : Ab Body : Pinkish earthenware Glaze : green Decoration : Incised floral designs on the body Size (cm) : Height: 24.8; Diameter of mouth: 14.2; Diameter of base: 9.4. Unearthed From : A tomb at Xigou, Linjiadi Township, Aohan Banner, Inner Mongolia Collected By : Aohan Banner Museum Date (AD) : Published by: Shao Guotian ed. 2004, pl. 143.</p>	 <p>Cat. 631</p>
<p>Catalogue No. : Cat. 632 Type : Ab Body : Porcelain Glaze : white Decoration : Size (cm) : Height: 7. Unearthed From : Collected By : Guan Baocong collection Date (AD) : Published by: Lu Jing 2003, pl. 3-362.</p>	 <p>Cat. 632</p>
<p>Catalogue No. : Cat. 633 Type : Ab Body : Porcelain Glaze : white Decoration : Size (cm) : Height: 7. Unearthed From : Collected By : Guan Baocong collection Date (AD) : Published by: Unpublished</p>	 <p>Cat. 633</p>
<p>Catalogue No. : Cat. 634 Type : Ab Body : Porcelain Glaze : white Decoration : Lobed belly Size (cm) : Height: 12.4; Diameter of mouth: 6; Diameter of belly: 13.2; Diameter of base: 7.2. Unearthed From : TZM2 Collected By : Date (AD) : late Published by: Liao Zhenjin & Wang Yi 2004, 31-37.</p>	 <p>Cat. 634</p>

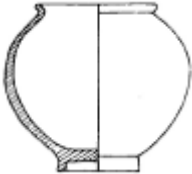
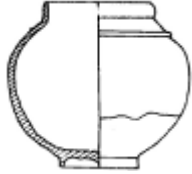
<p>Catalogue No. : Cat. 635 Type : Ba Body : Stoneware Glaze : White Decoration : Size (cm) : Height: 26. Unearthed From : HLB1 Collected By : Date (AD) : early Published by: Li Yufeng 1991, 106-19, fig.3:13.</p>	 <p>Cat. 635</p>
<p>Catalogue No. : Cat. 636 Type : Ba Body : pinkish earthenware Glaze : green Decoration : Size (cm) : Height: 8.3. Unearthed From : HLB1 Collected By : Date (AD) :middle II Published by: Feng Yongqian 1994a, 163-90, fig.11:1.</p>	 <p>Cat. 636</p>
<p>Catalogue No. : Cat. 637 Type : Ba Body : Pinkish earthenware Glaze : green Decoration : Size (cm) : Height: 7.4; Diameter of mouth: 4; Diameter of base: 7. Unearthed From : XHD Collected By : Date (AD) : middle Published by: Wang Gang 1998, 44-9, fig.4:5.</p>	 <p>Cat. 637</p>
<p>Catalogue No. : Cat. 638 Type : Bb Body : Buff stoneware Glaze : brown Decoration : Size (cm) : Height: 15.6. Unearthed From : YLYZ Collected By : Date (AD) : 942 Published by: Qi Xiaoguang et al. 1996, 4-32, fig. 48:6.</p>	 <p>Cat. 638</p>

<p>Catalogue No. : Cat. 639 Type : Bb Body : Pinkish earthenware Glaze : green Decoration : Size (cm) : Height: 27.2. Unearthed From : Collected By : Privat collection Date (AD) : Published by: Lu Jing 2003, pl. 3-369.</p>	 <p>Cat. 639</p>
<p>Catalogue No. : Cat. 640 Type : Bb Body : Pinkish earthenware Glaze : Three-colored Decoration : Incised herbaceous peonies Size (cm) : Height: 22. Unearthed From : Idemitsu Museum of Art, Tokyo Collected By : Date (AD) : Published by: Mok 1985, pl. 95.</p>	 <p>Cat. 640</p>
<p>Catalogue No. : Cat. 641 Type : Bb Body : Porcelain Glaze : white Decoration : Incised scroll peony designs on the shoulder and carved overlapping lotus pedals on the belly. Size (cm) : Height: 16; Diameter of mouth: 10.6; Diameter of base: 8. Unearthed From : tomb of Xiao He at Fuxin, Liaoning Collected By : Liaoning cultural relics research institute Date (AD) : late Published by: Wan Xiongfei 2005, 33-44, fig. 7,15..</p>	  <p>Cat. 641</p>
<p>Catalogue No. : Cat. 642 Type : Bb Body : Buff stoneware Glaze : green Decoration : Impressed "fish-egg" design at intervals on shoulder. Three incised encircling lines under the "fish eggs." Wavy comb lines covering the entire body. Size (cm) : Height: 7.6; Diameter of belly: 8.8. Unearthed From : Collected By : Center of Asian Art and Culture, Avery Brundage Collection, San Francisco, California Date (AD) : early Published by: Mino Yutaka et al. 1973, pl. 59.</p>	 <p>Cat. 642</p>

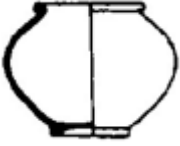
<p>Catalogue No. : Cat. 643 Type : Bb Body : Porcelain Glaze : brown Decoration : Size (cm) : Height: 15. Unearthed From : YLYZ Collected By : Date (AD) : 942 Published by: Qi Xiaoguang et al. 1996, 4-32, fig.48:5.</p>	 <p>Cat. 643</p>
<p>Catalogue No. : Cat. 644 Type : Bb Body : Porcelain Glaze : white Decoration : Size (cm) : Height: 16. Unearthed From : NZLYZ1 Collected By : Date (AD) : early Published by: Liaoningsheng wenwu kaogu yanjiusuo et al. 1992, 54-63, fig.3:3.</p>	 <p>Cat. 644</p>
<p>Catalogue No. : Cat. 645 Type : Bb Body : Porcelain Glaze : white Decoration : Size (cm) : Height: 16.8. Unearthed From : HLB1 Collected By : Date (AD) : early Published by: Li Yufeng 1991, 106-19, fig.3:11.</p>	 <p>Cat. 645</p>
<p>Catalogue No. : Cat. 646 Type : Bb Body : Pinkish earthenware Glaze : green Decoration : Size (cm) : Height: 9.7 Unearthed From : QHM2 Collected By : Date (AD) : 1057 Published by: Li Wenxin 1954, 163-202, fig.11:2.</p>	 <p>Cat. 646</p>

<p>Catalogue No. : Cat. 647 Type : Bb Body : stoneware Glaze : white Decoration : Carved scroll peony designs Size (cm) : Height: 19.8 Unearthed From : A tomb at Xiaoxigou, Niuyingzi Township, Kalaqin Banner, Inner Mongolia Collected By : Date (AD) : Published by: Feng Yongqian 1981c, 65-71, fig.17.</p>	 <p>Cat. 647</p>
<p>Catalogue No. : Cat. 648 Type : Bb Body : Pinkish earthenware Glaze : green Decoration : Size (cm) : Height: 10; Diameter of mouth: 6.4; Diameter of belly: 10.8. Unearthed From : QDC Collected By : Date (AD) : 1078 Published by: Li Bo 1995, 14-19, fig.4:5.</p>	 <p>Cat. 648</p>
<p>Catalogue No. : Cat. 649 Type : Bb Body : Pinkish earthenware Glaze : yellow Decoration : Size (cm) : Height: 10.8; Diameter of mouth: 7.5; Diameter of belly: 11.8. Unearthed From : QDC Collected By : Date (AD) : 1078 Published by: Li Bo 1995, 14-19, fig. 4:4.</p>	 <p>Cat. 649</p>
<p>Catalogue No. : Cat. 650 Type : Bb Body : stoneware Glaze : white Decoration : Size (cm) : Height ; 11. Unearthed From : Collected By : Guan Baocong collection Date (AD) : Published by: Lu Jing 2003, pl. 3-366.</p>	 <p>Cat. 650</p>

<p>Catalogue No. : Cat. 651 Type : Bb Body : stoneware Glaze : white Decoration : Size (cm) : Height: 7 Unearthed From : SHZC Collected By : Date (AD) : late Published by: Xin Jian & Cui Fulai 1991, 30-31.</p>	 <p>Cat. 651</p>
<p>Catalogue No. : Cat. 652 Type : Bb Body : stoneware Glaze : black Decoration : Size (cm) : Height: 24.7; Diameter of mouth: 12. Unearthed From : A tomb at liaoyang city, Liaoning province Collected By : Liaoning provincial museum Date (AD) : late Published by: Shanghai renmin meishu chubanshe 1986, pl. 46.</p>	 <p>Cat. 652</p>
<p>Catalogue No. : Cat. 653 Type : Bc Body : Porcelain Glaze : white Decoration : Carved overlapping lotus pedals on the body Size (cm) : Height: 9. Unearthed From : HYM Collected By : Date (AD) : 997 Published by: Huang Xiuchun et al. 1984, 361-81, fig.6:9.</p>	 <p>Cat. 653</p>
<p>Catalogue No. : Cat. 654 Type : Bc Body : Porcelain Glaze : white Decoration : Carved overlapping lotus pedals on the body Size (cm) : Height: 10. Unearthed From : SJG1 Collected By : Date (AD) : 1002 Published by: Deng Baoxue et al. 1983, 30-38, fig.2:4.</p>	 <p>Cat. 654</p>

Catalogue No. : Cat. 655
 Type : Bc
 Body : Porcelain
 Glaze : white
 Decoration : Carved overlapping lotus pedals on the body
 Size (cm) : Height: 11.5.
 Unearthed From : Pagoda JGS
 Collected By :
 Date (AD) : 1013
 Published by: Su Tianjun 1964, 49-53, fig.6:12.



Cat. 655

Catalogue No. : Cat. 656
 Type : Bc
 Body : Porcelain
 Glaze : white
 Decoration : Carved overlapping lotus pedals on the body
 Size (cm) : Height: 9.
 Unearthed From : KL3
 Collected By :
 Date (AD) : middle II
 Published by: Wang Jianqun & Chen Xiangwei 1989, 51, fig.37:4.

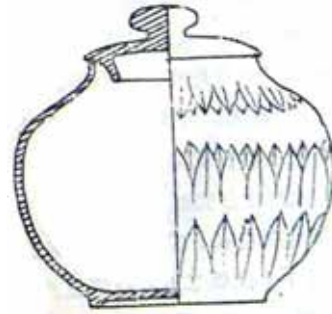







Cat. 656

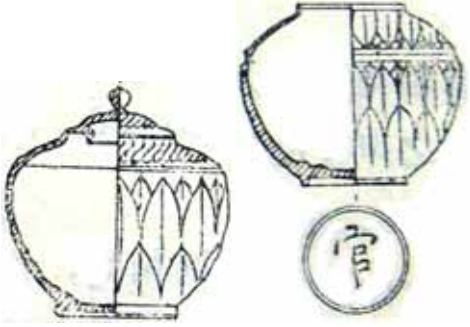

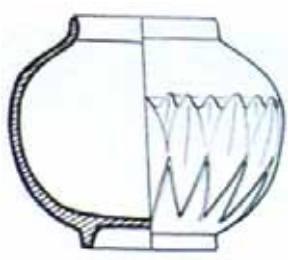

Catalogue No. : Cat. 657
 Type : Bc
 Body : Porcelain
 Glaze : white
 Decoration : Carved overlapping lotus pedals on the body; Incised "Guan" mark on the base.
 Size (cm) : Height: 11.4; Diameter of mouth: 5.8; Diameter of belly: 10.2.
 Unearthed From : CGGZ
 Collected By : Research institute of cultural relics and archaeology of Inner Mongolia
 Date (AD) : 1018
 Published by: Neimenggu zizhiqu wenhuating & Zhongguo lishi bowuguan 2002, pl. 244; Neimenggu wenwu kaogu yanjiusuo et al. 1993, 53, fig.32-4.

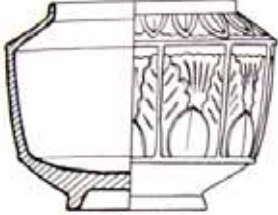



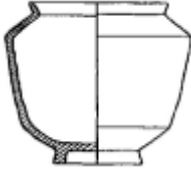

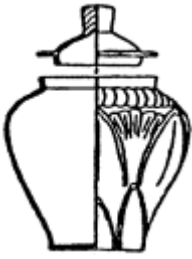

Cat. 657

<p>Catalogue No. : Cat. 658 Type : Bc Body : Porcelain Glaze : white Decoration : Carved overlapping lotus pedals on the body; Incised "Guan" mark on the base. Size (cm) : Height: 12.. Unearthed From : GYY Collected By : Date (AD) : 1020 Published by: Zhu Zifang & Xu Ji 1983, 168-95, fig.20:9,17.</p>	 <p>Cat. 658</p>
<p>Catalogue No. : Cat. 659 Type : Bc Body : Porcelain Glaze : white Decoration : Carved overlapping lotus pedals on the body. Size (cm) : Height: 12.8; Diameter of belly: 10.6. Unearthed From : SQ1 Collected By : Liaoning provincial museum Date (AD) : Published by: Xu Yulin 1977, 44-51.</p>	 <p>Cat. 659</p>
<p>Catalogue No. : Cat. 660 Type : Bc Body : Porcelain Glaze : white Decoration : Carved overlapping lotus pedals on the body. Size (cm) : Height: 7.8; Diameter of belly: 10.2. Unearthed From : Collected By : Royal Ontario Museum, Toronto Date (AD) : Published by: Mino Yutaka et al. 1973, pl. 47.</p>	 <p>Cat. 660</p>
<p>Catalogue No. : Cat. 661 Type : Bc Body : Porcelain Glaze : white Decoration : Carved overlapping lotus pedals on the body. Size (cm) : Height: 11.5. Unearthed From : LQW kiln site Collected By : Beijing cultural relics research institute Date (AD) : Published by: Beijingshi wenwu yanjiusuo 2002, 141, fig.44:3.</p>	 <p>Cat. 661</p>



<p>Catalogue No. : Cat. 662 Type : Bc Body : Porcelain Glaze : white Decoration : Carved overlapping plantain leaves on the body. Size (cm) : Height: 12.6. Unearthed From : LQW kiln site Collected By : Beijing cultural relics research institute Date (AD) : late Published by: Beijingshi wenwu yanjiusuo 2002, 141, fig.44:1, pl.5:4.</p>	 <p>Cat. 662</p>
<p>Catalogue No. : Cat. 663 Type : Bc Body : Porcelain Glaze : white Decoration : Carved overlapping plantain leaves on the body. Size (cm) : Height: 11.6 Unearthed From : LQW kiln site Collected By : Beijing cultural relics research institute Date (AD) : late Published by: Beijingshi wenwu yanjiusuo 2002, 236, fig.78:6..</p>	 <p>Cat. 663</p>
<p>Catalogue No. : Cat. 664 Type : Bc Body : Buff stoneware Glaze : white Decoration : Incised peony designs Size (cm) : Height: 13.3; Diameter of mouth: 10.5. Unearthed From : Collected By : Liaoning Provincial Museum Date (AD) : Published by: Zhongguo taoci quanji bianji weiyuanhui 1999, pl. 12; Shanghai renmin meishu chubanshe 1986, pl. 16; Liaoningsheng bowuguan 1961, pl. 62.</p>	 <p>Cat. 664</p>
<p>Catalogue No. : Cat. 665 Type : Bc Body : Porcelain Glaze : white Decoration : Size (cm) : Height: 15; Diameter of mouth: 7.7; Diameter of base:6.2.Amount : 1 Unearthed From : QHM1 Collected By : Date (AD) : 1044 Published by: Li Wenxin 1954, 163-202, fig.4:1..</p>	 <p>Cat. 665</p>



<p>Catalogue No. : Cat. 666 Type : Bc Body : Buff stonware Glaze : white Decoration : Size (cm) : Height: 14; Diameter of mouth: 10.8; Diameter of base:7. Unearthed From : YS3 Collected By : Date (AD) : late Published by: Shao Guotian et al.1999c, 1-38, 43, fig.16:8.</p>	 <p>Cat. 666</p>
<p>Catalogue No. : Cat. 667 Type : Bc Body : Buff stonware Glaze : white Decoration : Size (cm) : Height: 9.8. Unearthed From : WZM Collected By : Date (AD) : 1053 Published by: Beijingshi wenwu guanlichu 1972, 35-40, fig.1:left.</p>	 <p>Cat. 667</p>
<p>Catalogue No. : Cat. 668 Type : Bc Body : Buff stonware Glaze : white Decoration : Size (cm) : Height: 8.2. Unearthed From : Collected By : Guan Baocong collection Date (AD) : Published by: Lu Jing 2003, pl. 3-376.</p>	 <p>Cat. 668</p>
<p>Catalogue No. : Cat. 669 Type : Bd Body : Porcelain Glaze : white Decoration : Incised encircling line on shoulder. Incised and impressed decoration covers the body. Size (cm) : Height: 12.5; Diameter of belly: 12.5. Unearthed From : Collected By : The Cleveland Museum of Art, John L. Severance Fundation Date (AD) : Published by: Mino Yutaka et al. 1973, pl. 40.</p>	 <p>Cat. 669</p>



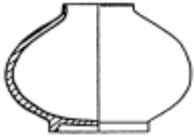
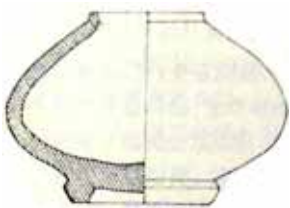

<p>Catalogue No. : Cat. 670 Type : Bd Body : Porcelain Glaze : brown Decoration : Size (cm) : Height: 14.4. Unearthed From : YLYZ Collected By : Date (AD) : 942 Published by: Qi Xiaoguang et al. 1996, 4-32, fig.48:7.</p>	 <p>Cat. 670</p>
<p>Catalogue No. : Cat. 671 Type : Bd Body : Porcelain Glaze : white Decoration : Carved overlapping lotus pedals on the body. Size (cm) : Height: 10.8. Unearthed From : XBTB (MWG4) Collected By : Date (AD) : 1069-1081 Published by: Ji Ping & Ta La 1997, 609-30, fig. 28:3.</p>	 <p>Cat. 671</p>
<p>Catalogue No. : Cat. 672 Type : Bd Body : Stoneware Glaze : white Decoration : Decorated with black painted floral and vertical lines designs on the body. Size (cm) : Height: 15. Unearthed From : Collected By : Guan Baocong collection Date (AD) : late Published by: Lu Jing 2003, pl. 3-380.</p>	 <p>Cat. 672</p>
<p>Catalogue No. : Cat. 673 Type : Bd Body : Stoneware Glaze : white Decoration : Wide, carved floral band with peonies covers upper part of the body. Dark brown iron glaze on ground of the peony, spray band. Size (cm) : Height: 20.4; Diameter of mouth: 17.6; Diameter of base: 13.4. Unearthed From : A tomb at Jijiyngzi, Shuangjingzi Township, Aohan Banner, Inner Mongolia Collected By : Aohan Banner Museum, Inner Mongolia Date (AD) : late Published by: Shao Guotian ed.2004, pl. 184.</p>	 <p>Cat. 673</p>

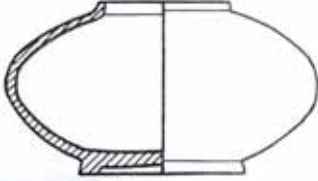
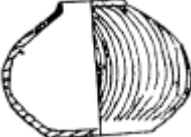

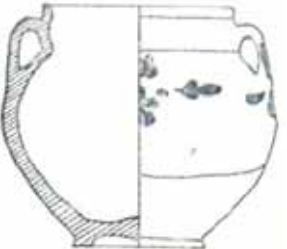

<p>Catalogue No. : Cat. 674 Type : Bd Body : Stoneware Glaze : white Decoration : Wide, carved floral band with peonies covers upper part of the body. Dark brown iron glaze on ground of the peony, spray band. Size (cm) : Height: 29.9; Diameter of mouth: 23.6;Diameter of base: 14.3. Unearthed From : Collected By : Shanghai Museum Date (AD) : late Published by: Zhongguo taoci quanji bianji weiyuanhui 1999, pl. 55.</p>	 <p>Cat. 674</p>
<p>Catalogue No. : Cat. 675 Type : Bd Body : Stoneware Glaze : white Decoration : Wide, carved floral band with peonies covers upper part of the body. Dark brown iron glaze on ground of the peony, spray band. Size (cm) : Height:50.8. Unearthed From : Collected By : The Metropolitan Museum of Art, New York Date (AD) : late Published by: Mino Yutaka et al. 1973, pl. 29.</p>	 <p>Cat. 675</p>
<p>Catalogue No. : Cat. 676 Type : Bd Body : Stoneware Glaze : white Decoration : Decorated with incised peony scroll through white slip with black glazed painted on the ground. Size (cm) : Height: 29.9; Diameter of mouth: 23.6. Unearthed From : a Liao site at Chengzi Township, Chifeng City, Inner Mongolia Collected By : Shanghai museum Date (AD) : late Published by: Shanghai renmin meishu chubanshe 1986, pl. 103.</p>	 <p>Cat. 676</p>

<p>Catalogue No. : Cat. 677 Type : Bd Body : Stoneware Glaze : white Decoration : Decorated with incised peony scroll through white slip with black glazed painted on the ground. Size (cm) : Height: 28.5; Diameter of mouth: 25. Unearthed From : Collected By : Kazuo museum, Chaoyang city, Liaoning province Date (AD) : late Published by: Shanghai renmin meishu chubanshe 1986, pl. 144.</p>	 <p>Cat. 677</p>
<p>Catalogue No. : Cat. 678 Type : Bd Body : Stoneware Glaze : white Decoration : Decorated with incised peony scroll through white slip with black glazed painted on the ground. Size (cm) : Height: 48. Unearthed From : Chifeng City, Inner Mongolia Collected By : Date (AD) : late Published by: Mok 1985, pl. 92.</p>	 <p>Cat. 678</p>
<p>Catalogue No. : Cat. 679 Type : Bd Body : Stoneware Glaze : white Decoration : Decorated with incised peony scroll through white slip with black glazed painted on the ground. Size (cm) : Height: 18.5; Diameter of mouth: 25.5. Unearthed From : A Liao site at Chengzi Township, Chifeng city, Inner Mongolia Collected By : Chifeng municipal museum Date (AD) : late Published by: Zhongguo taoci quanji bianji weiyuanhui 1999, pl.52.</p>	 <p>Cat. 679</p>
<p>Catalogue No. : Cat. 680 Type : Bd Body : Buff stoneware Glaze : white Decoration : Carved floral designs on the shoulder. Size (cm) : Height: 55.8; Diameter of mouth: 41. Unearthed From : QCY kiln site at Datong, Shanxi province Collected By : Datong municipal museum Date (AD) : 1102 Published by: Zhongguo taoci quanji bianji weiyuanhui 1999, pl. 34.</p>	 <p>Cat. 680</p>

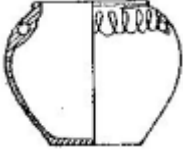

<p>Catalogue No. : Cat. 681 Type : Bd Body : Buff stoneware Glaze : white Decoration : Incised floral designs on the body; ink inscription on the bottom. Size (cm) : Height: 26.5; Diameter of mouth: 15.8. Unearthed From : At a tomb at Datong, Shanxi province Collected By : Datong municipal museum Date (AD) : 1102 Published by: Zhongguo taoci quanji bianji weiyuanhui 1999, pl. 33.</p>	 <p>Cat. 681</p>
<p>Catalogue No. : Cat. 682 Type : Ca Body : Buff stoneware Glaze : green Decoration : Six lobed body; Incised grass-flower design on each lobe of body. Size (cm) : Height: 14.4; Diameter of belly: 11.2. Unearthed From : Collected By : Center of Asian Art and Culture, Avery Brundage Collection, San Francisco, California Date (AD) : Published by: Mino Yutaka et al. 1973, pl. 58.</p>	 <p>Cat. 682</p>
<p>Catalogue No. : Cat. 683 Type : Ca Body : Stoneware Glaze : white Decoration : Size (cm) : Height: 4.5. Unearthed From : XTM(MWG3) Collected By : Date (AD) : 1070 Published by: Ji Ping & Ta La 1997, 609-30, fig. 15:4.</p>	 <p>Cat. 683</p>
<p>Catalogue No. : Cat. 684 Type : Ca Body : Stoneware Glaze : white Decoration : Size (cm) : Height: 4. Unearthed From : BTYZ Collected By : Date (AD) : late Published by: Feng Yongqian 1960, 15-74, fig.9:4..</p>	 <p>Cat. 684</p>



<p>Catalogue No. : Cat. 685 Type : Ca Body : Stoneware Glaze : white Decoration : Size (cm) : Height: 3.4. Unearthed From : YMT2 Collected By : Date (AD) : late Published by: Feng Yongqian 1994a, 163-90, fig.4:4...</p>	 <p>Cat. 685</p>
<p>Catalogue No. : Cat. 686 Type : Cb Body : Porcelain Glaze : white Decoration : Carved vertical lines on the body Size (cm) : Height: 3.8. Unearthed From : JSM Collected By : Date (AD) : late Published by: Cheng Tangdong & Li Xingsheng 1988.</p>	 <p>Cat. 686</p>
<p>Catalogue No. : Cat. 687 Type : Da Body : Stoneware Glaze : white Decoration : Decorated with floral designs painted in black on white ground Size (cm) : Height: 17; Diameter of mouth: 14.5; Diameter of base: 9. Unearthed From : Nailingao, Aohan Banner, Inner Mongolia Collected By : Aohan Banner Museum, Inner Mongolia Date (AD) : late Published by: Shao Guotian 1980, 94-95, fig. 4; Shao Guotian ed. 2004, pl. 149.</p>	 <p>Cat. 687</p>
<p>Catalogue No. : Cat. 688 Type : Da Body : Stoneware Glaze : white Decoration : Decorated with floral designs painted in black on white ground Size (cm) : Height: 11.6. Unearthed From : Nailingao, Aohan Banner, Inner Mongolia Collected By : Aohan Banner Museum, Inner Mongolia Date (AD) : late Published by: Shao Guotian 1980, 94-95, fig. 3.</p>	 <p>Cat. 688</p>

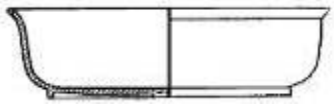
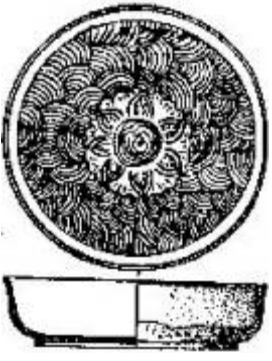
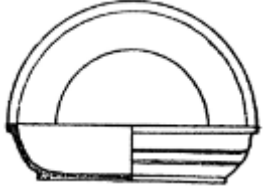

<p>Catalogue No. : Cat. 689 Type : Da Body : Stoneware Glaze : white Decoration : Size (cm) : Height: 18.7; Diameter of mouth: 12.7; Diameter of base: 9.2. Unearthed From : Collected By : Guan Baocong collection Date (AD) : late Published by: Lu Jing 2003, pl. 4-31.</p>	 <p>Cat. 689</p>
<p>Catalogue No. : Cat. 690 Type : Da Body : Pinkish earthenware Glaze : yellow Decoration : Size (cm) : Height: 15.5. Unearthed From : Collected By : Guan Baocong collection Date (AD) : late Published by: Lu Jing 2003, pl. 3-365.</p>	 <p>Cat. 690</p>
<p>Catalogue No. : Cat. 691 Type : Da Body : Stoneware Glaze : white Decoration : painted with floral designs in black on white ground Size (cm) : Height: 14. Unearthed From : Collected By : Date (AD) : late Published by: Mok 1985, pl. 88.</p>	 <p>Cat. 691</p>
<p>Catalogue No. : Cat. 692 Type : Da Body : Stoneware Glaze : white Decoration : Size (cm) : Height: 10.2; Diameter of mouth: 9.5; Diameter of base: 6.5. Unearthed From : Collected By : Guan Baocong collection Date (AD) : late Published by: Lu Jing 2003, pl. 4-32.</p>	 <p>Cat. 692</p>

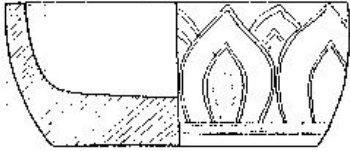

<p>Catalogue No. : Cat. 693 Type : Da Body : Stoneware Glaze : white Decoration : Size (cm) : Height: 12 Unearthed From : PJG Collected By : Date (AD) : late Published by: Ji Ping 1997, 639-50, fig. 8:6.</p>	 <p>Cat. 693</p>
<p>Catalogue No. : Cat. 694 Type : Da Body : Stoneware Glaze : white Decoration : Black painted desgn Size (cm) : Height: 10.2; Diameter of mouth: 8.4; Diameter of belly: 11.3; Diameter of base: 5.8. Unearthed From : Collected By : Liaoning provincial museum Date (AD) : late Published by: Liaoningsheng bowuguan 1961, pl. 59.</p>	 <p>Cat. 694</p>
<p>Catalogue No. : Cat. 695 Type : Da Body : Stoneware Glaze : white Decoration : Black painted desgn Size (cm) : Height: 14; Diameter of mouth: 10.2; Diameter of belly: 15.6; Diameter of base: 7.7. Unearthed From : Collected By : Liaoning provincial museum Date (AD) : late Published by: Liaoningsheng bowuguan 1961, pl. 60.</p>	 <p>Cat. 695</p>
<p>Catalogue No. : Cat. 696 Type : Db Body : Stoneware Glaze : white Decoration : Size (cm) : Height: 5.2-5.7; Diameter of mouth: 2.7-3.2; Diameter of base: 4.3-4.7. Unearthed From : Collected By : Guan Baocong collection Date (AD) : late Published by: Lu Jing 2003, pl. 4-30.</p>	 <p>Cat. 696</p>

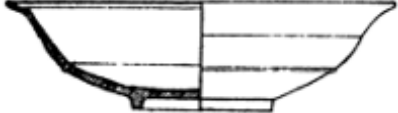
3.12 BASIN

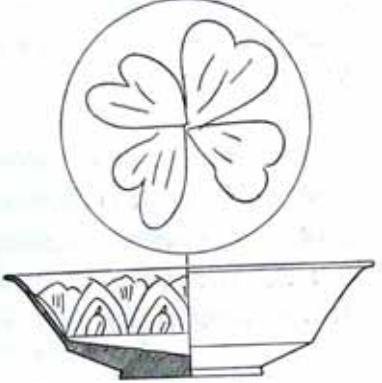
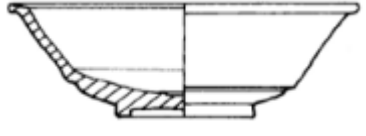
<p>Catalogue No. : Cat. 697 Type : A Body : Buff stoneware Glaze : green Decoration : Size (cm) : Height: 8; Diameter of mouth: 26.4. Unearthed From : DQTL3 Collected By : Date (AD) : early Published by: Meng Jianren & Piao Chunyue 1997, 651-67, fig.6:3.</p>	 <p>Cat. 697</p>
<p>Catalogue No. : Cat. 698 Type : A Body : Pinkish earthenware Glaze : yellow Decoration : Impressed lotus and waves design Size (cm) : Height: 8; Diameter of mouth: 32. Unearthed From : QHZ Collected By : Date (AD) : middle Published by: Fu Zhanjun 1990, 49-51, fig.2:7.</p>	 <p>Cat. 698</p>
<p>Catalogue No. : Cat. 699 Type : A Body : stoneware Glaze : Tea-dust green Decoration : Size (cm) : Height: 6.9; Diameter of mouth: 31.5; Diameter of base: 23. Unearthed From : SQ1 Collected By : Date (AD) : middle Published by: Xu Yulin 1977, 44-51.</p>	 <p>Cat. 699</p>
<p>Catalogue No. : Cat. 700 Type : A Body : Pinkish earthenware Glaze : green Decoration : Size (cm) : Height: 8.8; Diameter of mouth: 37.2. Unearthed From : DXG1 Collected By : Date (AD) : middle Published by: Xin Yan & Hua Yubing 1991, 40-47, fig.3:4.</p>	 <p>Cat. 700</p>

<p>Catalogue No. : Cat. 701 Type : A Body : stoneware Glaze : white Decoration : Size (cm) : ? Unearthed From : FMM Collected By : Date (AD) : 959 Published by: Zheng Shaozong 1956, 1-26, fig.6:4.</p>	 <p>Cat. 701</p>
<p>Catalogue No. : Cat. 702 Type : A Body : stoneware Glaze : white Decoration : Size (cm) : Height: 8.2; Diameter of mouth: 25.8; Diameter of base ; 19.4. Unearthed From : CGGZ Collected By : Date (AD) : 1018 Published by: Neimenggu wenwu kaogu yanjiusuo et al. 1993, 53, fig.32:5.</p>	 <p>Cat. 702</p>
<p>Catalogue No. : Cat. 703 Type : A Body : Pinkish earthenware Glaze : yellow Decoration : Size (cm) : Height: 6.4; Diameter of mouth: 18.6. Unearthed From : BL3 Collected By : Date (AD) : late Published by: Wu Jiachang 1986, 32-51, fig.17:1.</p>	 <p>Cat. 703</p>
<p>Catalogue No. : Cat. 704 Type : A Body : Pinkish earthenware Glaze : yellow Decoration : Size (cm) : Height: 8.7; Diameter of mouth: 31.4. Unearthed From : JFYZ Collected By : Date (AD) : late Published by: Xiang Chunsong 1979, 330-34,fig.3:5.</p>	 <p>Cat. 704</p>

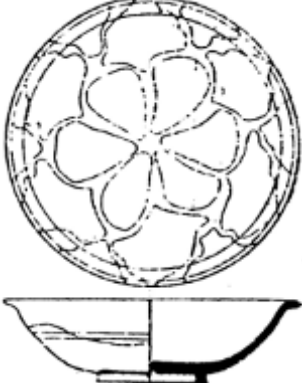
<p>Catalogue No. : Cat. 705 Type : A Body : Pinkish earthenware Glaze : white Decoration : Size (cm) : Height: 10.8; Diameter of mouth: 36.8. Unearthed From : QHM2 Collected By : Date (AD) : 1057 Published by: Li Wenxin 1954, 163-202, fig.15:1.</p>	 <p>Cat. 705</p>
<p>Catalogue No. : Cat. 706 Type : A Body : Pinkish earthenware Glaze : yellow Decoration : Size (cm) : Height: 9.4; Diameter of mouth: 29; Diameter of base: 11.5. Unearthed From : Tomb at Kangjiazhangzi, Jianpin, Liaoning province Collected By : Research Institute of Cultral relics and archaeology of Liaoning Province Date (AD) : late Published by: Lü Xueming 1997, 24-9, fig.7:11.</p>	 <p>Cat. 706</p>
<p>Catalogue No. : Cat. 707 Type : A Body : Stoneware Glaze : White Decoration : Size (cm) : Height: 11; Diameter of mouth: 39. Unearthed From : Collected By : Guan Baocong collection Date (AD) : late Published by: Lu Jing 2003, pl. 3-390.</p>	 <p>Cat. 707</p>
<p>Catalogue No. : Cat. 708 Type : A Body : Pinkish earthenware Glaze : green Decoration : Incised lotus and fish designs Size (cm) : Height: 8; Diameter of mouth: 28. Unearthed From : Collected By : Provate collection Date (AD) : late Published by: Lu Jing 2003, pl. 3-397.</p>	 <p>Cat. 708</p>

<p>Catalogue No. : Cat. 709 Type : A Body : Pinkish earthenware Glaze : yellow Decoration : Size (cm) : Height: 8; Diameter of mouth: 20.5. Unearthed From : Collected By : Guan Baocong collection Date (AD) : late Published by: Lu Jing 2003, pl. 3-392.</p>	 <p>Cat. 709</p>
<p>Catalogue No. : Cat. 710 Type : A Body : Pinkish earthenware Glaze : Yellow and green Decoration : Size (cm) : Height: 9.5; Diameter of mouth: 31. Unearthed From : XLZZ1 Collected By : Date (AD) : late Published by: Li Yiyou 1961, pl. 44-49, fig.4:4.</p>	 <p>Cat. 710</p>
<p>Catalogue No. : Cat. 711 Type : A Body : Stoneware Glaze : White Decoration : Carved slip peony designs Size (cm) : Height: 7.7; Diameter of mouth: 26.5; Diameter of base: 7.7. Unearthed From : Collected By : Guan Baocong collection Date (AD) : late Published by: Lu Jing 2003, pl. 4-224.</p>	 <p>Cat. 711</p>
<p>Catalogue No. : Cat. 712 Type : A Body : Stoneware Glaze : White Decoration : Carved slip peony designs Size (cm) : Height: 7; Diameter of mouth: 27. Unearthed From : Collected By : Liaoning tieling qunzhongyishuguan wenwuzu Date (AD) : late Published by: Shanghai renmin meishu chubanshe 1986, pl. 101.</p>	 <p>Cat. 712</p>

Catalogue No. : Cat. 713
 Type : A
 Body : Stoneware
 Glaze : White
 Decoration : Carved slip peony designs
 Size (cm) : Height: 7; Diameter of mouth: 28;
 Diameter of base: 10.1.
 Unearthed From : YMT3
 Collected By : Liaoning provincial museum
 Date (AD) : late
 Published by: Liaoningsheng bowuguan 1961, pl.
 104 ;



Cat. 713

Catalogue No. : Cat. 714
 Type : A
 Body : Pinkish earthenware
 Glaze : Three-colored
 Decoration : Incised and painted designs
 Size (cm) : Height: 7; Diameter of mouth: 24.
 Unearthed From : XLC
 Collected By :
 Date (AD) : late
 Published by: Aluke'erqin qi wenguansuo et al. 1996,
 78-81, fig.2:1.

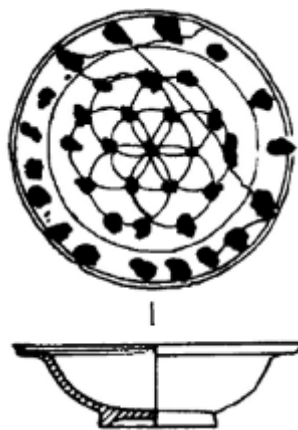





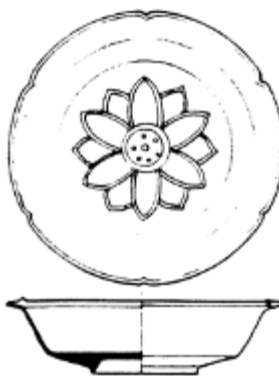

Cat. 714



Catalogue No. : Cat. 715
 Type : A
 Body : Pinkish earthenware
 Glaze : Yellow and green
 Decoration : Incised lotus designs
 Size (cm) : Height: 6.8; Diameter of mouth: 26.5.
 Unearthed From : ZSB
 Collected By :
 Date (AD) : 1115-1144
 Published by: Tao Zongyi et al. 1990, 1-19, fig.27:1.

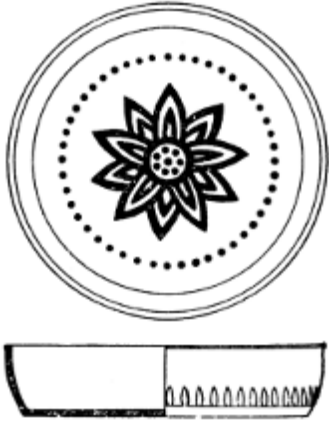





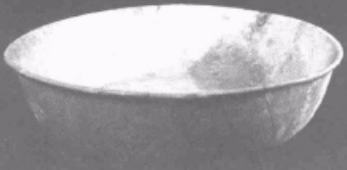

Cat. 715

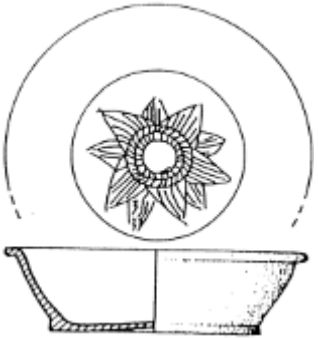
<p>Catalogue No. : Cat. 716 Type : A Body : Pinkish earthenware Glaze : Yellow and green Decoration : Incised lotus designs Size (cm) : Height: 7.5; Diameter of mouth: 26.5. Unearthed From : ZWZ Collected By : Date (AD) : 1093 Published by: Zheng Shaozong 1996, 14-46, fig.21:1.</p>	 <p>Cat. 716</p>
<p>Catalogue No. : Cat. 717 Type : A Body : Stoneware Glaze : white Decoration : Size (cm) : Height: 12.2; Diameter of mouth: 38.5. Unearthed From : A tomb at Dalaming'anla of Meilihe commune in Chifeng City, Inner Mongolia Collected By : Chifeng Municipal Museum, Inner Mongolia Date (AD) : late Published by : Shanhai renmin meishu chubanshe 1986, pl. 156.</p>	 <p>Cat. 717</p>
<p>Catalogue No. : Cat. 718 Type : B Body : Buff stoneware Glaze : green Decoration : Size (cm) : Height: 9.5; Diameter of mouth: 36.5. Unearthed From : DQTL3 Collected By : Date (AD) : early Published by: Meng Jianren & Piao Chunyue 1997, 651-67, fig.8:2.</p>	 <p>Cat. 718</p>

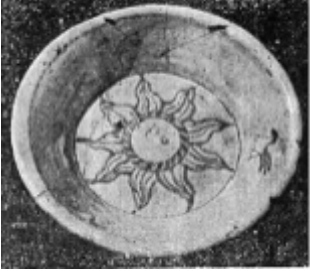



<p>Catalogue No. : Cat. 719 Type : B Body : Pinkish earthenware Glaze : green Decoration : Size (cm) : Height: 7.5; Diameter of mouth: 31.5. Unearthed From : QCH Collected By : Date (AD) : middle Published by: Geng Fengyi 1980, 17-29, fig.14; Shanghai renmin meishu chubanshe 1986, pl. 90.</p>	 <p>Cat. 719</p>
<p>Catalogue No. : Cat. 720 Type : B Body : Pinkish earthenware Glaze : green Decoration : Size (cm) : Height: 6.8; Diameter of mouth: 32. Unearthed From : Collected By : Guan Baocong collection Date (AD) : middle Published by: Lu Jing 2003 ,pl. 3-400.</p>	 <p>Cat. 720</p>
<p>Catalogue No. : Cat. 721 Type : Body : Gold Glaze : Decoration : Size (cm) : Height: 6.1; Diameter of mouth:16.8; Diameter of base ; 13.8. Unearthed From : CGGZ Collected By : Date (AD) : 1018 Published by: Neimenggu wenwu kaogu yanjiusuo et al. 1993.</p>	 <p>Cat. 721</p>
<p>Catalogue No. : Cat. 722 Type : B Body : Pinkish earthenware Glaze : green Decoration : Size (cm) : Height: 6.8; Diameter of mouth: 31.7; Diameter of base ; 21.6. Unearthed From : YMT22 Collected By : Date (AD) : middle Published by: Xu Zhiguo & Wei Chunguang 2000, 48-51, fig.3:6.</p>	 <p>Cat. 722</p>

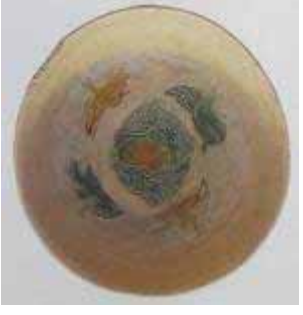



<p>Catalogue No. : Cat. 723 Type : B Body : Pinkish earthenware Glaze : white Decoration : Size (cm) : Height: 8; Diameter of mouth:32; Diameter of base: 17.6. Unearthed From : HTH1 Collected By : Date (AD) : middle Published by: Zhongguo shekeyuan neimenggu gongzuodui et al. 2003, 3-14, fig.7:2.</p>	 <p>Cat. 723</p>
<p>Catalogue No. : Cat. 724 Type : B Body : Pinkish earthenware Glaze : green Decoration : Size (cm) : Height: 8.9; Diameter of mouth: 35.7; Diameter of base: 27. Unearthed From : LBB Collected By : Date (AD) : middle II Published by: Lin Maoyu & Xian Junyan 2001, 36-43.</p>	 <p>Cat. 724</p>
<p>Catalogue No. : Cat. 725 Type : B Body : Pinkish earthenware Glaze : green Decoration : Size (cm) : Height: 8.5; Diameter of mouth: 33.6; Diameter of base: 25. Unearthed From : XHD Collected By : Date (AD) : middle III Published by: Wang Gang 1998, 44-9, fig.3:2.</p>	 <p>Cat. 725</p>
<p>Catalogue No. : Cat. 726 Type : B Body : Pinkish earthenware Glaze : green Decoration : Size (cm) : ? Unearthed From : A tomb at Heping Village, Dayingzi Township, Linxi county, Inner Mongolia Collected By : Date (AD) : middle II Published by: Feng Yongqian 1981c, 65-71, fig.8.</p>	 <p>Cat. 726</p>

<p>Catalogue No. : Cat. 727 Type : B Body : Pinkish earthenware Glaze : white Decoration : Incised floral design with green painted Size (cm) : Height: 8.2; Diameter of mouth: 28.6. Unearthed From : DSLT1 Collected By : Date (AD) : middle II Published by: Wan Xin 1999, 15-23, fig. 7:10.</p>	 <p>Cat. 727</p>
<p>Catalogue No. : Cat. 728 Type : B Body : Pinkish earthenware Glaze : white Decoration : Incised floral design Size (cm) : Height: 7.8; Diameter of mouth: 21.7. Unearthed From : Collected By : Guan Baocong collection Date (AD) : middle II Published by: Lu Jing 2003, pl. 3-403.</p>	 <p>Cat. 728</p>
<p>Catalogue No. : Cat. 729 Type : B Body : Pinkish earthenware Glaze : white Decoration : Incised floral design Size (cm) : Height: 8.3; Diameter of mouth: 31.5. Unearthed From : CGB11 Collected By : Date (AD) : middle II Published by: Dong Wenyi 1984, pl. 91-93, fig.2:1.</p>	 <p>Cat. 729</p>
<p>Catalogue No. : Cat. 730 Type : B Body : Pinkish earthenware Glaze : white Decoration : Incised floral design with green painted Size (cm) : Height: 6.1; Diameter of mouth: 26.5. Unearthed From : A tomb at Beishan of Hongqi Village, Tianshankou Township, Aluke'erqin Banner, Inner Mongolia Collected By : Date (AD) : middle II Published by: Feng Yongqian 1981c, 65-71, fig.13.</p>	 <p>Cat. 730</p>

<p>Catalogue No. : Cat. 731 Type : B Body : Pinkish earthenware Glaze : white Decoration : Incised floral design with green painted Size (cm) : Height: 8.5; Diameter of mouth: 32. Unearthed From : CKTDS4 Collected By : Chifeng municipal museum, Inner Mongolia Date (AD) : late Published by: Liu Bing et al. 1998, 26-34, 38, fig.11:1.</p>	 <p>Cat. 731</p>
<p>Catalogue No. : Cat. 732 Type : B Body : Pinkish earthenware Glaze : white Decoration : Incised floral design with green painted Size (cm) : Height: 7.5; Diameter of mouth: 30.5. Unearthed From : Collected By : Guan Baocong collection Date (AD) : late Published by: Lu Jing 2003, pl. 3-406.</p>	 <p>Cat. 732</p>
<p>Catalogue No. : Cat. 733 Type : B Body : Pinkish earthenware Glaze : white Decoration : Incised floral design with green painted Size (cm) : Height: 6.6; Diameter of mouth: 27.3. Unearthed From : Collected By : Guan Baocong collection Date (AD) : Published by: Lu Jing 2003, pl. 3-405.</p>	 <p>Cat. 733</p>
<p>Catalogue No. : Cat. 734 Type : B Body : Pinkish earthenware Glaze : white Decoration : Incised floral design with green painted Size (cm) : Height: 10; Diameter of mouth: 31.7; Diameter of base: 21.7. Unearthed From : a tomb at Yimatu, Beizifu township, Aohan Banner, Inner Mongolia Collected By : Aohan Banner Museum, Inner Mongolia Date (AD) : Published by: Shao Guotian ed. 2004, pl. 144.</p>	 <p>Cat. 734</p>

<p>Catalogue No. : Cat. 735 Type : B Body : Pinkish earthenware Glaze : white Decoration : Incised floral design with green painted Size (cm) : Height: 7.1; Diameter of mouth: 26; Diameter of base: 18.9. Unearthed From : A tomb at Shuangsheng village, Longchang township, Balin Left Banner, Inner Mongolia Collected By : Liaoshangjing Museum, Inner Mongolia Date (AD) : Published by: Tang Cailan, 2005, pl. 69-2.</p>	 <p>Cat. 735</p>
<p>Catalogue No. : Cat. 736 Type : B Body : Pinkish earthenware Glaze : white Decoration : Incised floral design Size (cm) : Height: 7.8; Diameter of mouth: 33.6. Unearthed From : Collected By : Private collection Date (AD) : Published by: Lu Jing 2003, pl. 3-401.</p>	 <p>Cat. 736</p>
<p>Catalogue No. : Cat. 737 Type : B Body : Pinkish earthenware Glaze : white Decoration : Incised floral design with green painted Size (cm) : Height: 8; Diameter of mouth: 32. Unearthed From : Collected By : Private collection Date (AD) : Published by: Lu Jing 2003, pl. 3-408.</p>	 <p>Cat. 737</p>
<p>Catalogue No. : Cat. 738 Type : B Body : Pinkish earthenware Glaze : white Decoration : Incised floral design Size (cm) : Height: 8.9; Diameter of mouth: 35.5; Diameter of base: 24.5. Unearthed From : YMT2 Collected By : Liaoning provincial museum Date (AD) : middle III Published by: Zhongguo taoci quanji bianji weiyuanhui 1999, pl. 106.</p>	 <p>Cat. 738</p>

<p>Catalogue No. : Cat. 739 Type : B Body : Pinkish earthenware Glaze : white Decoration : Incised floral design with green painted Size (cm) : Height: 8.4; Diameter of mouth: 32.1; Diameter of base: 20.1. Unearthed From : Collected By : Liaoning provincial museum Date (AD) : Published by: Zhongguo taoci quanji bianji weiyuanhui 1999, pl. 45.</p>	 <p>Cat. 739</p>
<p>Catalogue No. : Cat. 740 Type : B Body : Pinkish earthenware Glaze : white Decoration : Incised floral design with green painted Size (cm) : Height: 8; Diameter of mouth: 28.8. Unearthed From : Collected By : Private collection Date (AD) : Published by: Lu Jing 2003, pl. 3-409.</p>	 <p>Cat. 740</p>
<p>Catalogue No. : Cat. 741 Type : B Body : Pinkish earthenware Glaze : white Decoration : Incised floral design with green painted Size (cm) : Height: 8; Diameter of mouth: 31; Diameter of base: 19.5. Unearthed From : A tomb at Yousheng village, Baiyin'aobao township, Balin Left Banner, Inner Mongolia Collected By : Liaoshangjing museum, Inner Mongolia Date (AD) : Published by: Tang Cailan 2005, pl. 69-1.</p>	 <p>Cat. 741</p>
<p>Catalogue No. : Cat. 742 Type : B Body : Pinkish earthenware Glaze : white Decoration : Incised floral design with green painted Size (cm) : Height: 7; Diameter of mouth: 25.9. Unearthed From : Collected By : Guan Baocong collection Date (AD) : Published by: Lu Jing 2003, pl. 3-407.</p>	 <p>Cat. 742</p>

<p>Catalogue No. : Cat. 743 Type : B Body : Pinkish earthenware Glaze : white Decoration : Incised floral design with green painted Size (cm) : Hight: 5.7; Diameter of mouth: 25.1; Diameter of base: 14.7. Unearthed From : Collected By : Liaoning provincial museum Date (AD) : Published by: Zhongguo taoci quanji bianji weiyuanhui 1999, pl. 27.</p>	 <p>Cat. 743</p>
<p>Catalogue No. : Cat. 744 Type : B Body : Pinkish earthenware Glaze : white Decoration : Incised floral design with green painted Size (cm) : Diameter of mouth: 24.2. Unearthed From : Collected By : Mengdiexuan collection Date (AD) : Published by: So 2004, pl. : 24.</p>	 <p>Cat. 744</p>
<p>Catalogue No. : Cat. 745 Type : B Body : Stoneware Glaze : white Decoration : Incised floral design with green painted Size (cm) : Height: 5.4; Diameter of mouth: 34.9. Unearthed From : Collected By : Museum of Tongliao city, Inner Mongolia Date (AD) : Published by: Shen Hsueh-man 2006, pl. 108.</p>	 <p>Cat. 745</p>
<p>Catalogue No. : Cat. 746 Type : B Body : Pinkish earthenware Glaze : white Decoration : Incised floral design with green painted Size (cm) : Diameter of mouth: 32.5. Unearthed From : Collected By : Mengdiexuan collection Date (AD) : Published by: So 2004, pl. : 25.</p>	 <p>Cat. 746</p>

Catalogue No. : Cat. 747
 Type : B
 Body : Pinkish earthenware
 Glaze : white
 Decoration : Incised floral design with green painted
 Size (cm) : Hight: 8.8; Diameter of mouth: 35.4.
 Unearthed From : YMT2
 Collected By : Liaoning provincial museum
 Date (AD) : middle III
 Published by: Shanghai renmin meishu chubanshe
 1986, pl.66; Feng Yongqian 1994a, 163-90, fig.3:1.



Cat. 747

Catalogue No. : Cat. 748
 Type : B
 Body : Pinkish earthenware
 Glaze : white
 Decoration : Incised floral design with green painted
 Size (cm) : Hight: 8; Diameter of mouth: 27; Diameter
 of base: 14.
 Unearthed From : FJTGX
 Collected By : Chifeng municipal museum
 Date (AD) : late
 Published by: Aluke'erqin qi wenguansuo et al. 1996,
 78-81, fig.4:2.

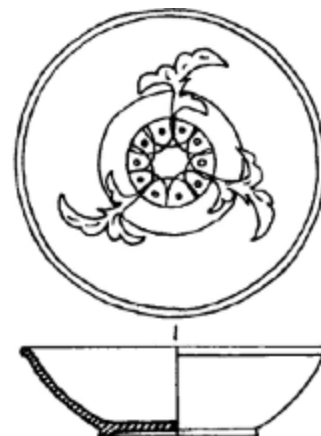

Cat. 748

Catalogue No. : Cat. 749
 Type : B
 Body : Pinkish earthenware
 Glaze : white
 Decoration : Incised floral design with green painted
 Size (cm) : Height: 6; Diameter of mouth: 27;
 Diameter of base: 16.5.
 Unearthed From : WJS1
 Collected By : Chifeng municipal museum
 Date (AD) : late
 Published by: Liu Bing et al. 1998, pl. 26-34, 38,
 fig.2:3.



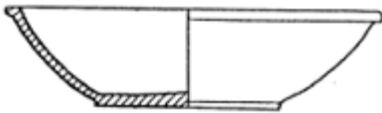

Cat. 749

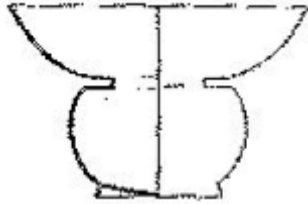
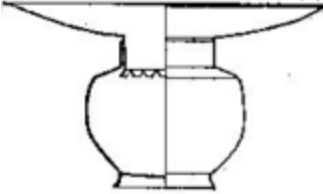

<p>Catalogue No. : Cat. 750 Type : B Body : Pinkish earthenware Glaze : white Decoration : Size (cm) : Height: 6.5; Diameter of mouth: 24.5. Unearthed From : XSC7 Collected By : Date (AD) : late Published by: Meng Jianren & Qian Yucheng 1994, 542-47, fig.3:4.</p>	 <p>Cat. 750</p>
---	--

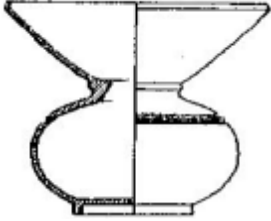
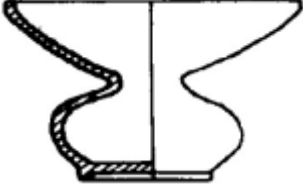
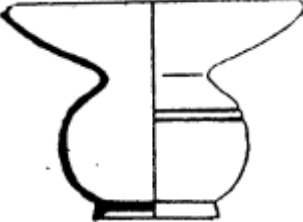
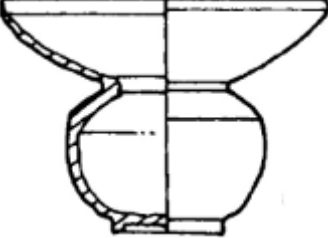
3.13 SPITTOON

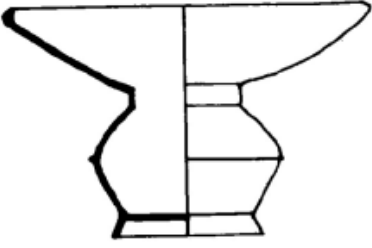
<p>Catalogue No. : Cat. 751 Type : Body : Gilt silver Glaze : Decoration : Floral designs Size (cm) : Height: 13.8; Diameter of mouth: 18. Unearthed From : Collected By : Research institute of cultural relics and Archaeology of Inner Mongolia Date (AD) : early Published by: Zhang Jingming 2005, pl. 102.</p>	 <p>Cat. 751</p>
<p>Catalogue No. : Cat. 752 Type : Body : silver Glaze : Decoration : Size (cm) : Height: 16; Diameter of mouth: 24.5; Diameter of base: 9.5. Unearthed From : CGGZ Collected By : Zhelimumeng museum, Inner Mongolia Date (AD) : 1018 Published by: Neimenggu wenwu kaogu yanjiusuo et al. 1993, 43, fig.25:4.</p>	 <p>Cat. 752</p>
<p>Catalogue No. : Cat. 753 Type : Body : Grass Glaze : Decoration : Size (cm) : ? Unearthed From : BL1 Collected By : Liaoning provincial museum Date (AD) : middle II Published by: Wu Jiachang 1986, 32-51.</p>	 <p>Cat. 753</p>

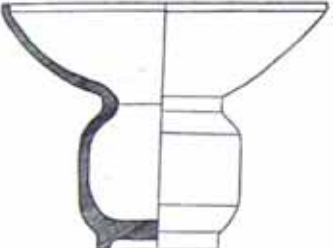
<p>Catalogue No. : Cat. 754 Type : A Body : Buff stoneware Glaze : green Decoration : Size (cm) : Height: 13.2; Diameter of mouth: 16.8. Unearthed From : DQTL3 Collected By : Date (AD) : early Published by: Meng Jianren & Piao Chunyue 1997, 651-67, fig.6:7.</p>	 <p>Cat. 754</p>
<p>Catalogue No. : Cat. 755 Type : A Body : Pinkish earthenware Glaze : green Decoration : Size (cm) : Height: 12.8; Diameter of mouth: 18.5; Diameter of base: 6.4. Unearthed From : XHD Collected By : Date (AD) : middle Published by: Wang Gang 1998, 44-9, fig.3:3.</p>	 <p>Cat. 755</p>
<p>Catalogue No. : Cat. 756 Type : A Body : Pinkish earthenware Glaze : green Decoration : Size (cm) : Height: 12; Diameter of mouth: 17. Unearthed From : ELC Collected By : Date (AD) : middle Published by: Zhang Baizhong 1985, 56-62, fig.4:7.</p>	 <p>Cat. 756</p>
<p>Catalogue No. : Cat. 757 Type : A Body : Stoneware Glaze : green Decoration : Size (cm) : Height: 12.8; Diameter of mouth: 17.4; Diameter of base: 6. Unearthed From : A tomb at Kangjiazhangzi, Jianping city, Liaoning province Collected By : Research institute of cultural relics and archaeology of Liaoning province Date (AD) : middle Published by: Lü Xueming 1997, 24-9, fig.7:6.</p>	 <p>Cat. 757</p>

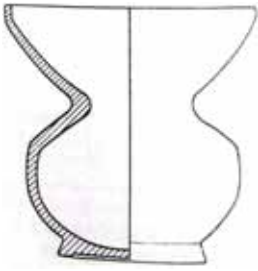
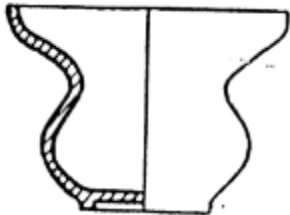

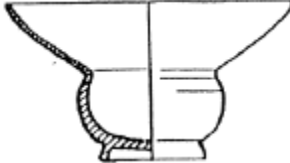
<p>Catalogue No. : Cat. 758 Type : A Body : Pinkish earthenware Glaze : green Decoration : Size (cm) : Height: 7. Unearthed From : YWG Collected By : Luanping museum, Hebei province Date (AD) : Middle Published by: Ma Qingpeng & Zhao Zhihou 1997, 47-49, fig.2:4.</p>	 <p>Cat. 758</p>
<p>Catalogue No. : Cat. 759 Type : A Body : Pinkish earthenware Glaze : yellow Decoration : Size (cm) : Height: 11.6; Diameter of mouth: 14.3. Unearthed From : Collected By : Guan Baocong collection Date (AD) : Published by: Lu Jing 2003, 3-429.</p>	 <p>Cat. 759</p>
<p>Catalogue No. : Cat. 760 Type : A Body : Pinkish earthenware Glaze : white Decoration : Size (cm) : Height: 9.7; Diameter of mouth: 13.5. Unearthed From : Collected By : Guan Baocong collection Date (AD) : Published by: Lu Jing 2003, 3-430.</p>	 <p>Cat. 760</p>
<p>Catalogue No. : Cat. 761 Type : A Body : Pinkish earthenware Glaze : white Decoration : Size (cm) : Height: 14; Diameter of mouth: 18.8. Unearthed From : QHM1 Collected By : Date (AD) : 1044 Published by: Li Wenxin 1954, pl. 163-202, fig.4:2, pl.5.</p>	 <p>Cat. 761</p>

<p>Catalogue No. : Cat. 762 Type : A Body : Pinkish earthenware Glaze : white Decoration : Size (cm) : Height: 16; Diameter of mouth: 20.7. Unearthed From : YMT2 Collected By : Date (AD) : late Published by: Feng Yongqian 1994a, 163-90, fig.4:6.</p>	 <p>Cat. 762</p>
<p>Catalogue No. : Cat. 763 Type : A Body : Pinkish earthenware Glaze : green Decoration : Size (cm) : Height: 9.5; Diameter of mouth: 13. Unearthed From : XSC4 Collected By : Date (AD) : late Published by: Meng Jianren & Qian Yucheng 1994, 542-47, fig. 3:7.</p>	 <p>Cat. 763</p>
<p>Catalogue No. : Cat. 764 Type : A Body : Pinkish earthenware Glaze : yellow Decoration : Size (cm) : Height: 11.5; Diameter of mouth: 10.8. Unearthed From : Collected By : Guan Baocong collection Date (AD) : late Published by: Lu Jing 2003, 3-422.</p>	 <p>Cat. 764</p>
<p>Catalogue No. : Cat. 765 Type : A Body : Pinkish earthenware Glaze : yellow Decoration : Size (cm) : Height: 12; Diameter of mouth: 20. Unearthed From : PJG3 Collected By : Date (AD) : late Published by: Ji Ping 1997, 639-50, fig. 8:2.</p>	 <p>Cat. 765</p>



<p>Catalogue No. : Cat. 766 Type : A Body : Pinkish earthenware Glaze : yellow Decoration : Size (cm) : Height: 10.7; Diameter of mouth: 18.8; Diameter of base: 6.5. Unearthed From : TJYZ Collected By : Date (AD) : late Published by: Zhao Guodong et al. 1997, 68-72, fig.4:5.</p>	 <p>Cat. 766</p>
<p>Catalogue No. : Cat. 767 Type : A Body : Pinkish earthenware Glaze : yellow Decoration : Size (cm) : Height: 15; Diameter of mouth: 15.8. Unearthed From : Collected By : Guan Baocong collection Date (AD) : late Published by: Lu Jing 2003, pl. 3-432.</p>	 <p>Cat. 767</p>
<p>Catalogue No. : Cat. 768 Type : A Body : Pinkish earthenware Glaze : yellow Decoration : Size (cm) : Height: 10.6; Diameter of mouth: 19.1. Unearthed From : Collected By : Liaoning provincial museum Date (AD) : late Published by: Shanghai renmin meishu chubanshe 1986, pl. 135.</p>	 <p>Cat. 768</p>
<p>Catalogue No. : Cat. 769 Type : A Body : Pinkish earthenware Glaze : yellow Decoration : Size (cm) : Height: 12.9; Diameter of mouth: 21.4; Diameter of base: 7.9.. Unearthed From : Collected By : Liaoning provincial museum Date (AD) : late Published by: Liaoningsheng bowuguan 1961, pl. 105.</p>	 <p>Cat. 769</p>

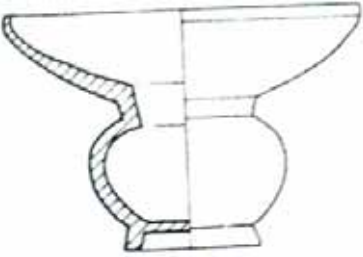
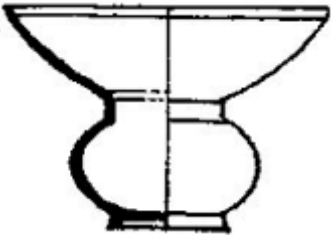

<p>Catalogue No. : Cat. 770 Type : A Body : Pinkish earthenware Glaze : yellow Decoration : Size (cm) : Height: 18.3 Unearthed From : XLZZ3 Collected By : Date (AD) : late Published by: Li Yiyou 1961, 44-49.</p>	 <p>Cat. 770</p>
<p>Catalogue No. : Cat. 771 Type : A Body : Porcelain Glaze : black Decoration : Size (cm) : Height: 6.5; Diameter of mouth: 12.8. Unearthed From : Collected By : Guan Baocong collection Date (AD) : Published by: Lu Jing 2003, pl. 4-124.</p>	 <p>Cat. 771</p>
<p>Catalogue No. : Cat. 772 Type : AV Body : Pinkish earthenware Glaze : green Decoration : Size (cm) : Height: 12.7; Diameter of mouth: 18.9. Unearthed From : Collected By : Guan Baocong collection Date (AD) : late Published by: Lu Jing 2003, pl. 3-428.</p>	 <p>Cat. 772</p>
<p>Catalogue No. : Cat. 773 Type : AV Body : Pinkish earthenware Glaze : yellow Decoration : Size (cm) : Height: 15; Diameter of mouth: 16. Unearthed From : Collected By : Guan Baocong collection Date (AD) : late Published by: Lu Jing 2003, pl. 3-431.</p>	 <p>Cat. 773</p>

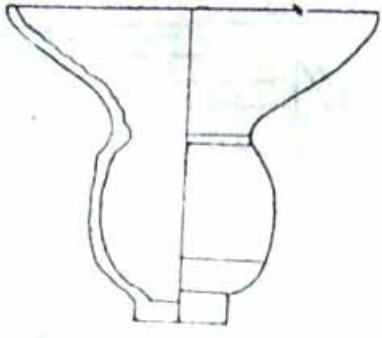
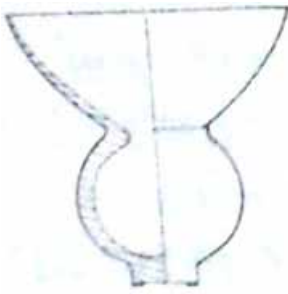
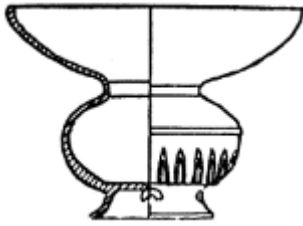
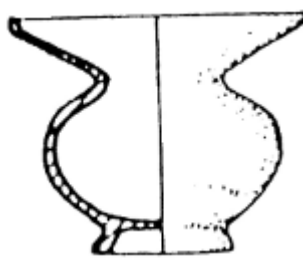
<p>Catalogue No. : Cat. 774 Type : AV Body : Pinkish earthenware Glaze : Yellow Decoration : Size (cm) : Height: 11.2; Diameter of mouth: 17.8; Diameter of base: 6.8. Unearthed From : Collected By : Aohan Banner Museum, Inner Mongolia Date (AD) : late Published by: Shao Guotian ed. 2004, pl. 141.</p>	 <p>Cat. 774</p>
<p>Catalogue No. : Cat. 775 Type : AV Body : Pinkish earthenware Glaze : green Decoration : Size (cm) : Height: 19. Unearthed From : XLZZ4 Collected By : Date (AD) : late Published by: Li Yiyu 1961, 44-49, fig.6.</p>	 <p>Cat. 775</p>
<p>Catalogue No. : Cat. 776 Type : AV Body : Pinkish earthenware Glaze : yellow Decoration : Size (cm) : Height: 11.4; Diameter of mouth: 18.8; Diameter of base: 6.1. Unearthed From : Collected By : The Place museum, Beijing Date (AD) : late Published by: Zhongguo taoci quanji bianji weiyuanhui 1999, pl. 71.</p>	 <p>Cat. 776</p>
<p>Catalogue No. : Cat. 777 Type : AV Body : Pinkish earthenware Glaze : yellow Decoration : Size (cm) : Height: 10.5; Diameter of mouth: 16.2. Unearthed From : ZSQ Collected By : Hebei provincial museum Date (AD) : 1116 Published by: Hebeisheng wenwu guanlichu et al. 1975, 31-39, fig.6.</p>	 <p>Cat. 777</p>

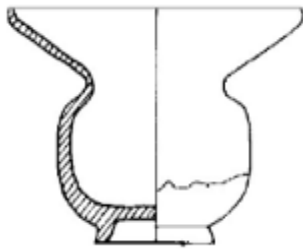

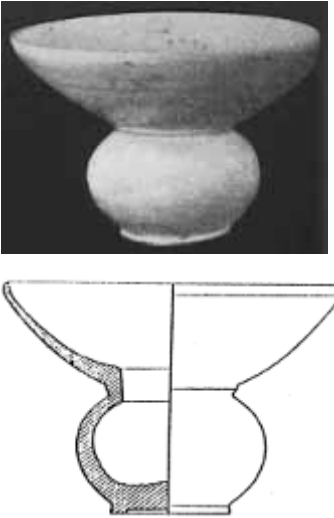

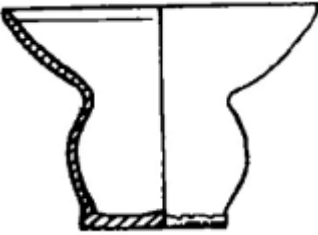
<p>Catalogue No. : Cat. 778 Type : AV Body : Pinkish earthenware Glaze : yellow Decoration : Size (cm) : Height: 11; Diameter of mouth: 16.3. Unearthed From : ZWZ Collected By : Date (AD) : 1093 Published by: Zheng Shaozong 1996, 16-36, fig.21:3.</p>	 <p>Cat. 778</p>
<p>Catalogue No. : Cat. 779 Type : AV Body : Pinkish earthenware Glaze : yellow Decoration : Size (cm) : Height: 10.6; Diameter of mouth: 16.1. Unearthed From : ZSB Collected By : Date (AD) : 1089-1144. Published by: Tao Zongyi et al. 1990, 1-19, fig.27:4.</p>	 <p>Cat. 779</p>
<p>Catalogue No. : Cat. 780 Type : AV Body : Pinkish earthenware Glaze : yellow Decoration : Size (cm) : Height: 7.5; Diameter of mouth: 16.2. Unearthed From : ZKZ Collected By : Date (AD) : 1093 Published by: Hebeisheng wenwu yanjiusuo et al. 1995, 1-22.</p>	 <p>Cat. 780</p>
<p>Catalogue No. : Cat. 781 Type : AV Body : Pinkish earthenware Glaze : white Decoration : Size (cm) : Height: 13; Diameter of mouth: 14.1. Unearthed From : Collected By : Guan Baocong collection Date (AD) : late Published by: Lu Jing 2003, pl. 3-430.</p>	 <p>Cat. 781</p>

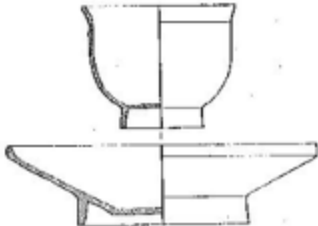

<p>Catalogue No. : Cat. 782 Type : A Body : Pinkish earthenware Glaze : yellow Decoration : Size (cm) : ?. Unearthed From : XDM Collected By : Date (AD) : late Published by: Xiang Chunsong 1991, 33-39, fig.4:3.</p>	 <p>Cat. 782</p>
<p>Catalogue No. : Cat. 783 Type : A Body : Pinkish earthenware Glaze : green Decoration : Size (cm) : ?. Unearthed From : HPYZ1 Collected By : Date (AD) : late Published by: Xiang Chunsong 1991, 33-39, fig.5:3.</p>	 <p>Cat. 783</p>
<p>Catalogue No. : Cat. 784 Type : B Body : Pinkish earthenware Glaze : green Decoration : With applied relief designs Size (cm) : Height: 16; Diameter of mouth: 21. Unearthed From : QCH Collected By : Liaoning provincial museum Date (AD) : middle Published by: Jin Fengyi 1980, 17-29, fig.13.</p>	 <p>Cat. 784</p>
<p>Catalogue No. : Cat. 785 Type : B Body : Pinkish earthenware Glaze : yellow Decoration : Size (cm) : Height: 12.2; Diameter of mouth: 15.2. Unearthed From : DSLT1 Collected By : Date (AD) : middle Published by: Wan Xin 1999, 15-23, fig.7:5,</p>	 <p>Cat. 785</p>

<p>Catalogue No. : Cat. 786 Type : B Body : Pinkish earthenware Glaze : white Decoration : Size (cm) : Height: 12.5; Diameter of mouth: 15.8. Unearthed From : WJS1 Collected By : Chifen municipal museum Date (AD) : late Published by: Liu Bing et al. 1998, 26-34, 38, fig. 2:4.</p>	 <p>Cat. 786</p>
<p>Catalogue No. : Cat. 787 Type : B Body : Pinkish earthenware Glaze : green Decoration : Size (cm) : Height: 9.4; Diameter of mouth: 13.3. Unearthed From : Collected By : Guan Baocong collection Date (AD) : late Published by: Lu Jing 2003, pl. 3-426.</p>	 <p>Cat. 787</p>
<p>Catalogue No. : Cat. 788 Type : B Body : Pinkish earthenware Glaze : white Decoration : Size (cm) : Height: 15; Diameter of mouth: 13.5. Unearthed From : Collected By : Guan Baocong collection Date (AD) : late Published by: Lu Jing 2003, pl. 3-424.</p>	 <p>Cat. 788</p>
<p>Catalogue No. : Cat. 789 Type : C Body : Porcelain Glaze : white Decoration : Size (cm) : Height: 12.5; Diameter of mouth: 18.7. Unearthed From : HYM Collected By : Date (AD) : 997 Published by: Huang Xiuchun et al. 1984, 361-81, fig.6:7.</p>	 <p>Cat. 789</p>

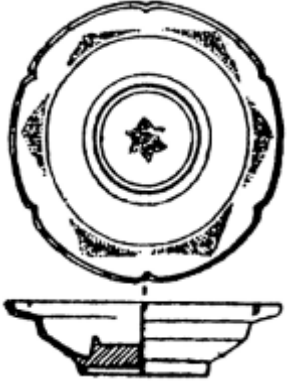
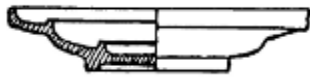
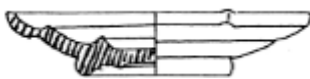

<p>Catalogue No. : Cat. 790 Type : C Body : Porcelain Glaze : white Decoration : Size (cm) : Height: 13.7; Diameter of mouth: 18.6. Unearthed From : Collected By : Guan Baocong collection Date (AD) : Published by: Lu Jing 2003, pl. 4-77.</p>	 <p>Cat. 790</p>
<p>Catalogue No. : Cat. 791 Type : C Body : Pinkish earthenware Glaze : White glaze with green painted Decoration : green Painted designs Size (cm) : Height: 9.4; Diameter of mouth: 12.6. Unearthed From : A tomb at Xinlin village, Xianfeng Township, Aluke'erqin Banner, Inner Mongolia Collected By : Date (AD) : late Published by: Aluke'erqin qi wenguansuo et al. 1996, 78-81, fig.2:1.</p>	 <p>Cat. 791</p>
<p>Catalogue No. : Cat. 792 Type : C Body : Pinkish earthenware Glaze : White glaze with green and yellow painted Decoration : With green and yellow Painted designs Size (cm) : Height: 13.6; Diameter of mouth: 20.9; Diameter of base: 6.8. Unearthed From : A tomb at Erbadi village, Yangchang Township, Balin Right Banner, Inner Mongolia Collected By : Baling Right Banner Museum, Inner Mongolia Date (AD) : late Published by: Neimenggu zizhiqu wenhuating & Zhongguo lishi bowuguan 2002, pl. 281.</p>	 <p>Cat. 792</p>
<p>Catalogue No. : Cat. 793 Type : D Body : Stoneware Glaze : white Decoration : Size (cm) : Height: 11.4; Diameter of mouth: 14.8; Diameter of base: 6.8. Unearthed From : Collected By : Liaoning Provincial Museum Date (AD) : Published by: Liaoningsheng bowuguan 1961, pl. 106; Shanghai renmin meishu chubanshe 1986, pl. 17.</p>	 <p>Cat. 793</p>

3.14 SAUCER

<p>Catalogue No. : Cat. 794 Type : A Body : Stoneware Glaze : green Decoration : Size (cm) : Height: 6. Unearthed From : DQTL3 Collected By : Date (AD) : early Published by: Meng Jianren & Piao Chunyue 1997, 651-67, fig.9.</p>	 <p>Cat. 794</p>
<p>Catalogue No. : Cat. 795 Type : A Body : Pinkish earthenware Glaze : green Decoration : Incised floral designs Size (cm) : Diameter of mouth: 15.8. Unearthed From : HLB1 Collected By : Date (AD) : early Published by: Li Yufeng 1991, 106-119, fig.4:2.</p>	 <p>Cat. 795</p>
<p>Catalogue No. : Cat. 796 Type : A Body : Pinkish earthenware Glaze : white Decoration : Size (cm) : Height: 3.8; Diameter of mouth: 15.6; Diameter of base: 8.4.. Unearthed From : HLB1 Collected By : Date (AD) : early Published by: Li Yufeng 1991, 106-119, fig.3:6.</p>	 <p>Cat. 796</p>
<p>Catalogue No. : Cat. 797 Type : A Body : Pinkish earthenware Glaze : green Decoration : Incised floral designs Size (cm) : Height: 4.5; Diameter of mouth: 15.1; Diameter of base: 6.3.. Unearthed From : A tomb at Yebaishou station, Jianping city, Liaoning Province Collected By : Liaoning Provincial Museum Date (AD) : early Published by: Li Yufeng 1991, 106-119; Liaoningsheng bowuguan 1961, pl. 92; Shanhai renmin meishu chubanshe 1986, pl. 164.</p>	 <p>Cat. 797</p>



<p>Catalogue No. : Cat. 798 Type : B Body : Pinkish earthenware Glaze : Green with yellow pigment Decoration : Impressed designs Size (cm) : Height: 3. Unearthed From : JCY Collected By : Date (AD) : 994 Published by: Tao Zongyi 1991, 67-71, .</p>	 <p>Cat. 798</p>
<p>Catalogue No. : Cat. 799 Type : A Body : Pinkish earthenware Glaze : Green Decoration : Size (cm) : Height: 3. Unearthed From : QCH Collected By : Date (AD) : 1004 Published by: Jin Fengyi 1980, 17-29, fig.11.</p>	 <p>Cat. 799</p>
<p>Catalogue No. : Cat. 800 Type : A Body : Pinkish earthenware Glaze : yellow Decoration : Size (cm) : Height: 3. Unearthed From : ZJYZ Collected By : Date (AD) : Published by: Feng Yongqian 1960, pl. 15-24, fig.2:4.</p>	 <p>Cat. 800</p>
<p>Catalogue No. : Cat. 801 Type : A Body : porcelain Glaze : white Decoration : Carved lotus designs Size (cm) : Height: 3.8; Diameter of mouth: 15.2; Diameter of base: 8.3. Unearthed From : A tomb at Yimawen, Beizifu Township, Aohan Banner, Inner Mongolia Collected By : Aohan Museum, Inner Mongolia Date (AD) : Published by: Shao Guotian ed. 2004, pl. 125; Neimenggu zizhiqiu wenhuating & Zhongguo lishi bowuguan 2002, pl. 241; Shen Hsueh-man 2006, pl. 107d.</p>	 <p>Cat. 801</p>

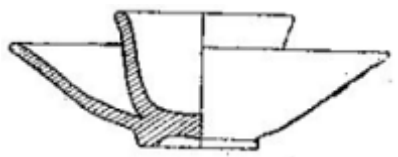

<p>Catalogue No. : Cat. 802 Type : A Body : porcelain Glaze : white Decoration : Size (cm) : ? Unearthed From : LQW kiln site Collected By : Date (AD) : Published by: Beijingshi wenwu yanjiusuo 2002, pl.5:3.</p>	 <p>Cat. 802</p>
<p>Catalogue No. : Cat. 803 Type : A Body : porcelain Glaze : white Decoration : Incised Guan mark Size (cm) : Height: 3.2; Diameter of mouth: 14; Diameter of base: 7. Unearthed From : A tomb at Hadatu village, Hadayngge Township, Balin Left Banner, Inner Mongolia Collected By : Liaoshangjing Museum, Inner Mongolia Date (AD) : Published by: Tang Cailan 2005, pl. 61.</p>	 <p>Cat. 803</p>
<p>Catalogue No. : Cat. 804 Type : B Body : porcelain Glaze : white Decoration : Size (cm) : Height: 4.9. Unearthed From : DQTL3 Collected By : Date (AD) : early Published by: Meng Jianren & Piao Chunyue 1997, pl. 651-67, fig. 10:1.</p>	 <p>Cat. 804</p>
<p>Catalogue No. : Cat. 805 Type : B Body : porcelain Glaze : white Decoration : Relief designs Size (cm) : Height: 3.7; Diameter of mouth: 14; Diameter of base: 8.5. Unearthed From : A tomb at Hadatu village, Hadayngge Township, Balin Left Banner, Inner Mongolia Collected By : Liaoshangjing Museum, Inner Mongolia Date (AD) : Published by: Tang Cailan 2005, pl. 67.</p>	 <p>Cat. 805</p>

<p>Catalogue No. : Cat. 806 Type : B Body : porcelain Glaze : white Decoration : With carved designs Size (cm) : Height: 3.6; Diameter of mouth: 14.1; Diameter of base: 7. Unearthed From : SQ1 Collected By : Liaoning Provincial Museum Date (AD) : middle II Published by: Xu Yulin 1977, 44-51; Zhongguo taoci quanji bianji weiyuanhui 1999, pl. 19; Shanhai renminmeishu chubanshe 1986, pl. 15.</p>	 <p>Cat. 806</p>
<p>Catalogue No. : Cat. 807 Type : B Body : porcelain Glaze : white Decoration : Size (cm) : Height: 3.5. Unearthed From : Collected By : Guan Baocong collection Date (AD) : Published by: unpublished</p>	 <p>Cat. 807</p>
<p>Catalogue No. : Cat. 808 Type : B Body : porcelain Glaze : white Decoration : Relief designs Size (cm) : Height: 4.9. Unearthed From : YLYN Collected By : Liaoning Provincial Museum Date (AD) : 986 Published by: Liaoningsheng bowuguan wenwu gongzuodui 1980, 18-22.</p>	 <p>Cat. 808</p>
<p>Catalogue No. : Cat. 809 Type : Ca Body : Pinkish earthenware Glaze : white Decoration : Size (cm) : Diameter of mouth: 15.7. Unearthed From : BL4 Collected By : Date (AD) : middle Published by: Wu Jiachang 1986, 32-51, fig.22.</p>	 <p>Cat. 809</p>

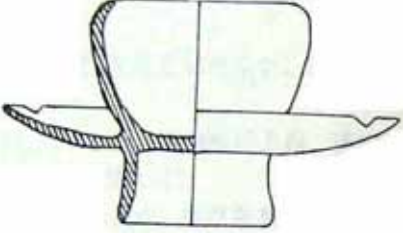
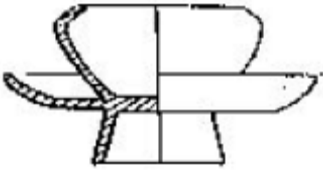
<p>Catalogue No. : Cat. 810 Type : Ca Body : porcelain Glaze : white Decoration : Size (cm) : Height: 6. Unearthed From : HXM Collected By : Date (AD) : 1017 Published by: Tang Yunming 1973, 276-278, pl.4:3.</p>	 <p>Cat. 810</p>
<p>Catalogue No. : Cat. 811 Type : Ca Body : Pinkish earthenware Glaze : white Decoration : Size (cm) : Height: 6.5; Diameter of mouth: 7.5.. Unearthed From : YMT2 Collected By : Date (AD) : middle II Published by: Feng Yongqian 1994a, 163-90, fig.1:2.</p>	 <p>Cat. 811</p>
<p>Catalogue No. : Cat. 812 Type : Ca Body : Pinkish earthenware Glaze : white Decoration : Size (cm) : Height: 6.7. Unearthed From : Collected By : Guan Baocong collection Date (AD) : Published by: Lu Jing 2003, pl. 3-444.</p>	 <p>Cat. 812</p>
<p>Catalogue No. : Cat. 813 Type : Ca Body : Pinkish earthenware Glaze : yellow Decoration : Size (cm) : Height: 7.2. Unearthed From : ZSB Collected By : Date (AD) : 1115-1144 Published by: Tao Zongyi et al. 1990, 1-19, fig.27:7.</p>	 <p>Cat. 813</p>

<p>Catalogue No. : Cat. 814 Type : Ca Body : Pinkish earthenware Glaze : yellow Decoration : Size (cm) : Height: 7.2. Unearthed From : ZWZ Collected By : Date (AD) : 1093 Published by: Zheng Shaozong 1996, 14-46, fig.21:5.</p>	 <p>Cat. 814</p>
<p>Catalogue No. : Cat. 815 Type : Ca Body : Pinkish earthenware Glaze : yellow Decoration : Size (cm) : Height: 7.3. Unearthed From : ZSB Collected By : Date (AD) : 1089-1144 Published by: Tao Zongyi et al. 1990, 1-19.</p>	 <p>Cat. 815</p>
<p>Catalogue No. : Cat. 816 Type : Ca Body : porcelain Glaze : white Decoration : Size (cm) : Height: 7.5. Unearthed From : MTYZ2 Collected By : Inner Mongolia autonomous region museum Date (AD) : early Published by: Zheng Long 1981, 231-43, fig.8:3.</p>	 <p>Cat. 816</p>
<p>Catalogue No. : Cat. 817 Type : Ca Body : Pinkish earthenware Glaze : yellow Decoration : Size (cm) : Height: 7.5. Unearthed From : XLZZ4 Collected By : Date (AD) : late Published by: Li Yiyou 1961-44-49, fig.7</p>	 <p>Cat. 817</p>

<p>Catalogue No. : Cat. 818 Type : Ca Body : Pinkish earthenware Glaze : brown Decoration : Size (cm) : Height: 6.6. Unearthed From : BTYZ Collected By : Date (AD) : late Published by: Feng Yongqian 1960, 15-24, fig.10:1.</p>	 <p>Cat. 818</p>
<p>Catalogue No. : Cat. 819 Type : Ca Body : Pinkish earthenware Glaze : brown Decoration : Size (cm) : Height: 6. Unearthed From : XFJ Collected By : Date (AD) : 1072 Published by: Neimenggu wenwu kaogu yanjiusuo et al. 1994, 548-52.</p>	 <p>Cat. 819</p>
<p>Catalogue No. : Cat. 820 Type : Ca Body : Pinkish earthenware Glaze : yellow Decoration : Size (cm) : Height: 7.4. Unearthed From : Collected By : Guan Baocong collection Date (AD) : late Published by: Lu Jing 2003, pl. 3-449.</p>	 <p>Cat. 820</p>
<p>Catalogue No. : Cat. 821 Type : Ca Body : Pinkish earthenware Glaze : yellow Decoration : Size (cm) : Height: 7.1. Unearthed From : Collected By : Guan Baocong collection Date (AD) : late Published by: Lu Jing 2003, pl. 3-447.</p>	 <p>Cat. 821</p>

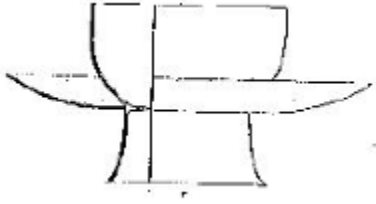
<p>Catalogue No. : Cat. 822 Type : Ca Body : Pinkish earthenware Glaze : yellow Decoration : Size (cm) : Height: 7.2; Diameter of mouth: 6.7. Unearthed From : Collected By : Liaoning Provincial Museum Date (AD) : late Published by: Shanghai renmin meishu chubanshe 1986, pl. 15.</p>	 <p>Cat. 822</p>
<p>Catalogue No. : Cat. 823 Type : Ca Body : Pinkish earthenware Glaze : yellow Decoration : Size (cm) : Height: 10.1; Diameter of mouth: 9.9. Unearthed From : Collected By : Chifeng Municipal Museum Date (AD) : late Published by: Shanghai renmin meishu chubanshe 1986, pl. 147.</p>	 <p>Cat. 823</p>
<p>Catalogue No. : Cat. 824 Type : Ca Body : Pinkish earthenware Glaze : yellow Decoration : Size (cm) : Height: 7.5; Diameter of mouth: 14.4; Diameter of base: 5.2. Unearthed From : Collected By : Liaoning provincial museum Date (AD) : late Published by: Liaoningsheng bowuguan 1961, pl. 91.</p>	 <p>Cat. 824</p>
<p>Catalogue No. : Cat. 825 Type : Ca Body : silver Glaze : Decoration : Size (cm) : Height: 7.8; Diameter of mouth: 8.4; Diameter of base: 6.8. Unearthed From : CGGZ Collected By : Date (AD) : 1018 Published by: Neimenggu wenwu kaogu yanjiusuo et al. 1993, 43, fig.25:2.</p>	 <p>Cat. 825</p>



<p>Catalogue No. : Cat. 826 Type : Cb Body : Pinkish earthenware Glaze : green Decoration : Size (cm) : Height: 6.5; Diameter of mouth: 15.2. Unearthed From : JFYZ Collected By : Chifeng municipal museum Date (AD) : late Published by: Xiang Chunsong 1979, 330-34, fig.3:3; Shanghai renmin meishu chubanshe 1986, pl. 134.</p>	  <p>Cat. 826</p>
<p>Catalogue No. : Cat. 827 Type : Cb Body : Pinkish earthenware Glaze : yellow Decoration : Size (cm) : Height: 7. Unearthed From : Collected By : Guan Baocong collection Date (AD) : late Published by: Lu Jing 2003, pl. 3-452.</p>	 <p>Cat. 827</p>
<p>Catalogue No. : Cat. 828 Type : D Body : porcelain Glaze : black Decoration : Size (cm) : Height: 3.5. Unearthed From : Collected By : Guan Baocong collection Date (AD) : late Published by: Lu Jing 2003, pl. 4-118.</p>	 <p>Cat. 828</p>
<p>Catalogue No. : Cat. 829 Type : D Body : porcelain Glaze : white Decoration : Size (cm) : Height: 6.5; Diameter of mouth: 10.9. Unearthed From : A tomb at Yongdingmenwai, Beijing Collected By : Capital Museum, Beijing Date (AD) : Published by: Shoudu bowuguan 1991, pl.39; Lu Jing 2003, pl. 3-455.</p>	 <p>Cat. 829</p>

<p>nCatalogue No. : Cat. 830 Type : D Body : Pinkish earthenware Glaze : green Decoration : Size (cm) : Height: 6.5 Unearthed From : Collected By : Guan Baocong collection Date (AD) : late Published by: Lu Jing 2003, pl. 3-457.</p>	 <p>Cat. 830</p>
<p>Catalogue No. : Cat. 831 Type : E Body : Pinkish earthenware Glaze : green Decoration : Size (cm) : ? Unearthed From : LQW kiln site Collected By : Date (AD) : late Published by: Beijingshi wenwu yanjiusuo 2002, pl.3:1.</p>	 <p>Cat. 831</p>

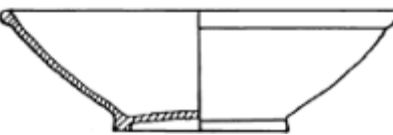
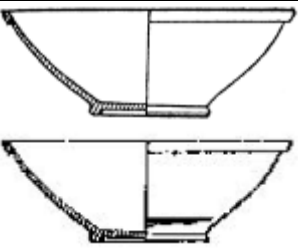
3.15 RING-FOOT BOWL

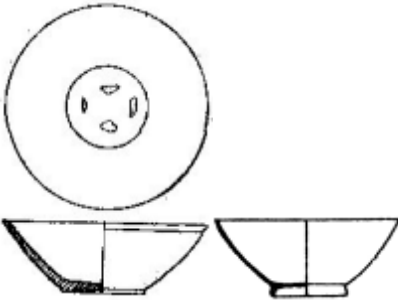
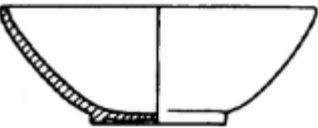
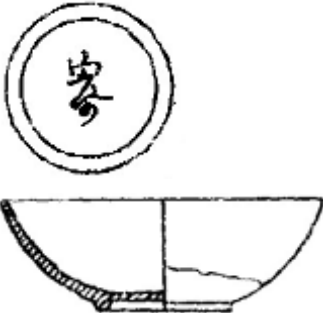

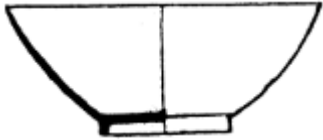

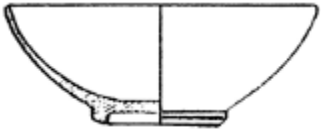
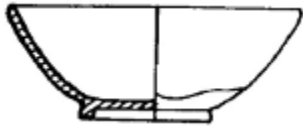
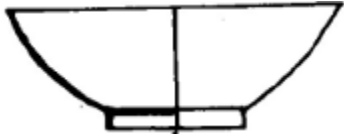
<p>Catalogue No. : Cat. 832 Type : Aa Body : Porcelain Glaze : white Decoration : Size (cm) : Height: 6.2; Diameter of mouth: 18.6; Diameter of base: 6.3. Unearthed From : DQTL3 Collected By : Date (AD) : early Published by : Meng Jianren & Piao Chunyue 1997, 651-67, fig.10:3.</p>	 <p>Cat. 832</p>
<p>Catalogue No. : Cat. 833 Type : Aa Body : Porcelain Glaze : white Decoration : Size (cm) : Height: 7; Diameter of mouth: 20.8; Diameter of base: 8.6. Unearthed From : SZG1 Collected By : Date (AD) : early Published by : Shao Guotian 1987, 889-904.</p>	 <p>Cat. 833</p>

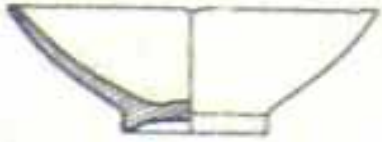
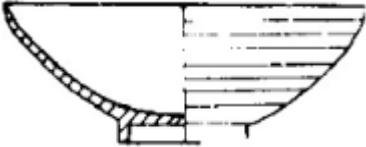
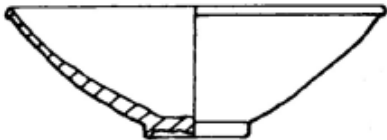
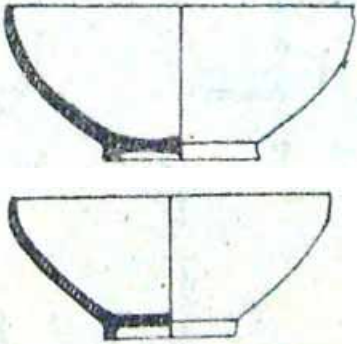

<p>Catalogue No. : Cat. 834 Type : Aa Body : Porcelain Glaze : white Decoration : Size (cm) : Height: 6.5. Unearthed From : A tomb at Sunjiawan, Chaoyang city, Liaoning province Collected By : Date (AD) : Early Published by : Sun Guoping et al. 1992.</p>	 <p>Cat. 834</p>
<p>Catalogue No. : Cat. 835 Type : Aa Body : Stoneware Glaze : white Decoration : Size (cm) : Height: 5.4; Diameter of mouth: 16 Unearthed From : BL1 Collected By : Liaoning provincial Museum Date (AD) : middle Published by : Wu Jiachang 1986, 32-45, fig.4:4, 4:2.</p>	 <p>Cat. 835</p>
<p>Catalogue No. : Cat. 836 Type : Aa Body : Stoneware Glaze : white Decoration : Size (cm) : Height: 4; Diameter of mouth: 11.2; Diameter of base: 1.8. Unearthed From : SLG6 Collected By : Date (AD) : middle Published by : Neimenggu wenwu kaogu yanjiusuo 1997, 60-67, fig.4:4.</p>	 <p>Cat. 836</p>
<p>Catalogue No. : Cat. 837 Type : Aa Body : Pinkish earthenware Glaze : white Decoration : Ink inscription of Chinese character "ji" on the ground. Size (cm) : Height: 4.9; Diameter of mouth: 14.1; Diameter of base: 5.8. Unearthed From : CGWS Collected By : Date (AD) : early Published by : Miao Runhua 1995, 20-4, fig.4:4.</p>	 <p>Cat. 837</p>

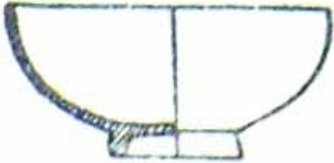

<p>Catalogue No. : Cat. 838 Type : Aa Body : Stoneware Glaze : white Decoration : Size (cm) : Height: 7; Diameter of mouth: 15.5; Diameter of base: 7.5. Unearthed From : GZX Collected By : Date (AD) : 1027 Published by : Zhu Zifang & Xu Ji 1983, 168-95, fig.4:9.</p>	 <p>Cat. 838</p>
<p>Catalogue No. : Cat. 839 Type : Aa Body : Pinkish earthenware Glaze : white Decoration : Size (cm) : Height: 4.5. Unearthed From : HYM Collected By : Date (AD) : 997 Published by : Huang Xiuchun et al. 1984, 361-81, fig.6:3.</p>	  <p>Cat. 839</p>
<p>Catalogue No. : Cat. 840 Type : Aa Body : Stoneware Glaze : white Decoration : Size (cm) : Height: 5; Diameter of mouth: 12.4; Diameter of base: 4.8. Unearthed From : XHD Collected By : Date (AD) : middle Published by : Wang Gang 1998, 44-9, fig.4:6.</p>	 <p>Cat. 840</p>
<p>Catalogue No. : Cat. 841 Type : Aa Body : Porcelain Glaze : white Decoration : Size (cm) : Height: 4; Diameter of mouth: 11; Diameter of base: 4.4. Unearthed From : YWG Collected By : Date (AD) : middle Published by : Ma Qingpeng & Zhao Zhihou 1997, 47-49, fig.2:1.</p>	 <p>Cat. 841</p>

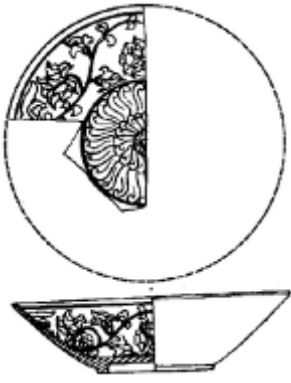

<p>Catalogue No. : Cat. 842 Type : Aa Body : Porcelain Glaze : white Decoration : Carved lotus pedals design Size (cm) : Height: 7.8; Diameter of mouth: 18.4; Diameter of base ; 6.8. Unearthed From : DXG1 Collected By : Date (AD) : middle Published by : Xin Yan & Hua Yubing 1991, 40-47, fig.3:1.</p>	 <p>Cat. 842</p>
<p>Catalogue No. : Cat. 843 Type : Aa Body : Porcelain Glaze : white Decoration : Size (cm) : Height: 6.8-7.5; Diameter of mouth: 17.8-23. Unearthed From : YMT8 Collected By : Date (AD) : late Published by : He Xianwu & Zhang Xingde 1996, 41-47, fig.4:1,5.</p>	 <p>Cat. 843</p>
<p>Catalogue No. : Cat. 844 Type : Aa Body : Pinkish earthenware Glaze : yellow Decoration : Size (cm) : Diameter of mouth: 13. Unearthed From : Collected By : Tokyo National Museum Date (AD) : late Published by : Mok 1985, pl.16.</p>	 <p>Cat. 844</p>
<p>Catalogue No. : Cat. 845 Type : Aa Body : Porcelain Glaze : white Decoration : Incised floral designs Size (cm) : Height: 8; Diameter of mouth: 23.5. Unearthed From : Sanshan township, Balin Left banner Collected By : Liaoshangjing Museum, Inner Mongolia Date (AD) : Published by : Tang Cailan 2005, pl. 68.</p>	 <p>Cat. 845</p>

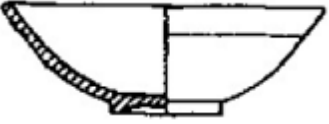

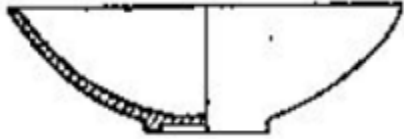

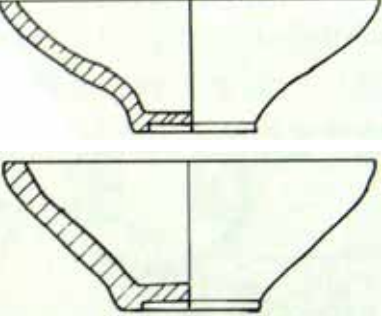
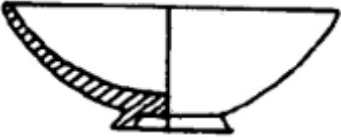
<p>Catalogue No. : Cat. 846 Type : Aa Body : Porcelain Glaze : white Decoration : Size (cm) : ? Unearthed From : AXZ Collected By : Date (AD) : middle Published by : Beijingshi wenwu yanjiusuo 1992, 17-23, fig.4:4.</p>	 <p>Cat. 846</p>
<p>Catalogue No. : Cat. 847 Type : Aa Body : Porcelain Glaze : white Decoration : Size (cm) : Height: 3.8; Diameter of mouth: 10.5. Unearthed From : CKTDS4 Collected By : Chifeng Municipal Museum, Inner Mongolia Date (AD) : late Published by : Liu Bing et al. 1998, 26-34,38, fig.11:3.</p>	 <p>Cat. 847</p>
<p>Catalogue No. : Cat. 848 Type : Aa Body : Porcelain Glaze : white Decoration : Size (cm) : Height: 4; Diameter of mouth: 12; Diameter of base: 3.4. Unearthed From : Tomb at Kangjiazhangzi, Jianping City, Liaoning Province M2:22 Collected By : Research institute of cultural relics and archaeology of Liaoning Province Date (AD) : middle Published by : Lü Xueming 1997, 24-9, fig.7:4.</p>	 <p>Cat. 848</p>
<p>Catalogue No. : Cat. 849 Type : Aa Body : Stoneware Glaze : white Decoration : Size (cm) : Height: 6; Diameter of mouth: 18.6. Unearthed From : ELC Collected By : Date (AD) : middle Published by : Zhang Baizhong 1985, 56-62, fig.4:4, 5.</p>	 <p>Cat. 849</p>

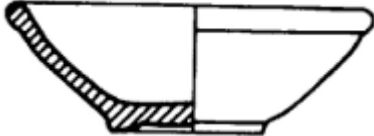
<p>Catalogue No. : Cat. 850 Type : Aa Body : Stoneware Glaze : white Decoration : Size (cm) : Height: 4; Diameter of mouth: 8.4. Unearthed From : ZKY Collected By : Date (AD) : 1060 Published by : Deng Baoxue et al.1983, 30-38, fig.18:1.</p>	 <p>Cat. 850</p>
<p>Catalogue No. : Cat. 851 Type : Aa Body : Stoneware Glaze : white Decoration : Size (cm) : Height: 4.6; Diameter of mouth: 12.2. Unearthed From : CGC Collected By : Date (AD) : late Published by : Hu Jian et al. 1998, ,25-28</p>	 <p>Cat. 851</p>
<p>Catalogue No. : Cat. 852 Type : Aa Body : Pinkish earthenware Glaze : yellow Decoration : Impressed floral designs Size (cm) : Height: 5.5; Diameter of mouth: 14.8. Unearthed From : Collected By : Liaoning Tieling qunzhongyishuguan wenwuzu Date (AD) : late Published by : Shanghai renmin meishu chubanshe 1986, pl. 95.</p>	 <p>Cat. 852</p>
<p>Catalogue No. : Cat. 853 Type : Aa Body : Stoneware Glaze : white Decoration : Carved lotus pedals design outside the bowl. Size (cm) : Height: 7.8; Diameter of mouth: 19.6; Diameter of base: 8. Unearthed From : A tomb at Beizifu Township, Aohan Banner, Inner Mongolia Collected By : Aohan Banner Museum, Inner Mongolia Date (AD) : late Published by : Shen Hsueh-man 2006, pl. 107b.</p>	 <p>Cat. 853</p>

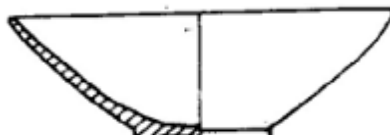
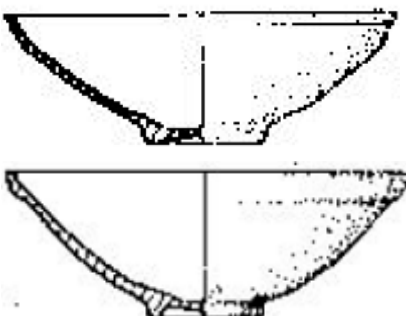
<p>Catalogue No. : Cat. 854 Type : Aa Body : Porcelain Glaze : white Decoration : Impressed floral designs in inner side Size (cm) : Height: 5; Diameter of mouth: 18.4; Diameter of base: 7.6. Unearthed From : YS1 Collected By : Date (AD) : late Published by : Shao Guotian et al. 1999, 1-38,43, fig.9:1.</p>	 <p>Cat. 854</p>
<p>Catalogue No. : Cat. 855 Type : Aa Body : Porcelain Glaze : white Decoration : Size (cm) : Height: 4; Diameter of mouth: 12.7; Diameter of base: 3.5. Unearthed From : QHZ Collected By : Date (AD) : late Published by : Fu Zhanjun 1990, 49-51, fig.2:5,6.</p>	 <p>Cat. 855</p>
<p>Catalogue No. : Cat. 856 Type : Aa Body : Porcelain Glaze : white Decoration : Size (cm) : Height: 4.2; Diameter of mouth: 13; Diameter of base: 3.6. Unearthed From : XNRM Collected By : Date (AD) : middle Published by : Wu Yaqin & Wang Ruiqing 2000, 32-5, fig.3:1.</p>	 <p>Cat. 856</p>
<p>Catalogue No. : Cat. 857 Type : Aa Body : Stoneware Glaze : white Decoration : Size (cm) : Height: 3.3; Diameter of mouth: 10.5; Diameter of base: 3.9. Unearthed From : YS3 Collected By : Date (AD) : late Published by : Shao Guotian et al. 1999, 1-38, 43, fig.16:5.</p>	 <p>Cat. 857</p>

<p>Catalogue No. : Cat. 858 Type : Aa Body : Porcelain Glaze : white Decoration : Size (cm) : Height: 4; Diameter of mouth: 12.7. Unearthed From : XSC4 Collected By : Date (AD) : late Published by : Meng Jianren & Qian Yucheng 1994, 542-47, fig.3:6.</p>	 <p>Cat. 858</p>
<p>Catalogue No. : Cat. 859 Type : Aa Body : Porcelain Glaze : white Decoration : Size (cm) : height: 6. Unearthed From : CGB11 Collected By : Date (AD) : middle Published by : Dong Wenyi 1984, 91-93, fig.2:4.</p>	 <p>Cat. 859</p>
<p>Catalogue No. : Cat. 860 Type : Aa Body : Stoneware Glaze : white Decoration : Size (cm) : Height: 8; Diameter of mouth: 21; Diameter of base: 7. Unearthed From : GSZ2 Collected By : Date (AD) : late Published by : Yang Dongxin 2001, 87-88, fig.4:2,3.</p>	 <p>Cat. 860</p>
<p>Catalogue No. : Cat. 861 Type : Aa Body : Pinkish earthenware Glaze : green Decoration : Size (cm) : Height: 3.8; Diameter of mouth: 10.5; Diameter of base: 3.5. Unearthed From : FJTGX Collected By : Date (AD) : late Published by : Aluke'erqin qi wenguansuo et al. 1996, 78-81, fig.4:4.</p>	 <p>Cat. 861</p>

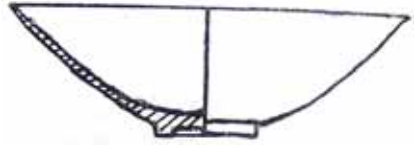

<p>Catalogue No. : Cat. 862 Type : Aa Body : Stoneware Glaze : white Decoration : Size (cm) : Height: 3.9; Diameter of mouth: 11.2; Diameter of base: 5. Unearthed From : GMZ Collected By : Date (AD) : late Published by : Li Dajun 1997, 30-6, fig.7:4.</p>	 <p>Cat. 862</p>
<p>Catalogue No. : Cat. 863 Type : Aa Body : Stoneware Glaze : white Decoration : Size (cm) : Height: 4.3; Diameter of mouth: 12; Diameter of base: 4.1. Unearthed From : ZDB Collected By : Date (AD) : early Published by : Chaoyangshi bowuguan 2004, 64-66.</p>	 <p>Cat. 863</p>
<p>Catalogue No. : Cat. 864 Type : Aa Body : Stoneware Glaze : white Decoration : Size (cm) : Height: 3.6; Diameter of mouth: 10.8; Diameter of base: 4. Unearthed From : QDC Collected By : Date (AD) : 1078 Published by : Li Bo 1995, 14-19.</p>	 <p>Cat. 864</p>
<p>Catalogue No. : Cat. 865 Type : Aa Body : Stoneware Glaze : white Decoration : Size (cm) : Height: 4.5; Diameter of mouth: 12.6; Diameter of base: 4.2. Unearthed From : MJ1 Collected By : Date (AD) : late Published by : Wan Xin 1999, 15-23, fig.7:4,9.</p>	 <p>Cat. 865</p>



<p>Catalogue No. : Cat. 866 Type : Aa Body : Stoneware Glaze : white Decoration : Size (cm) : Height: 6.5-7.5; Diameter of mouth: 18-24. Unearthed From : KL6 Collected By : Date (AD) : late Published by : Zhelimumeng bowuguan et al. 1982, 35-46, 28, fig.9:8.</p>	 <p>Cat. 866</p>
<p>Catalogue No. : Cat. 867 Type : Aa Body : Porcelain Glaze : white Decoration : Size (cm) : Height: 6.8; Diameter of mouth: 20. Unearthed From : YMT8 Collected By : Date (AD) : late Published by : He Xianwu & Zhang Xingde 1996, 41-47, fig.4:3.</p>	 <p>Cat. 867</p>
<p>Catalogue No. : Cat. 868 Type : Aa Body : Stoneware Glaze : white Decoration : Size (cm) : Height: 3.4; Diameter of mouth: 10.5. Unearthed From : HQYZ3 Collected By : Date (AD) : late Published by : Wumeng wenwu gongzuozhan 1985, 7-44, fig.21.</p>	 <p>Cat. 868</p>
<p>Catalogue No. : Cat. 869 Type : Aa Body : Stoneware Glaze : white Decoration : Size (cm) : Height: 4.1; Diameter of mouth: 10.5; Diameter of base: 3.7. Unearthed From : Collected By : Guan Baocong collection Date (AD) : late Published by : Lu Jing 2003, pl. 4-44.</p>	 <p>Cat. 869</p>

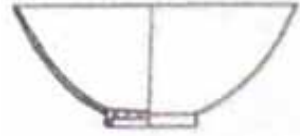

<p>Catalogue No. : Cat. 870 Type : Aa Body : Stoneware Glaze : white Decoration : Size (cm) : Height: 2.8; Diameter of mouth: 8.5; Diameter of base: 2.8. Unearthed From : Collected By : Guan Baocong collection Date (AD) : late Published by : Lu Jing 2003, pl. 4-40.</p>	 <p>Cat. 870</p>
<p>Catalogue No. : Cat. 871 Type : Aa Body : Stoneware Glaze : white Decoration : Size (cm) : Height: 4.6; Diameter of mouth: 11.8; Diameter of base: 4.2. Unearthed From : Collected By : Guan Baocong collection Date (AD) : late Published by : Lu Jing 2003, pl. 4-49</p>	 <p>Cat. 871</p>
<p>Catalogue No. : Cat. 872 Type : Aa Body : Stoneware Glaze : white Decoration : Size (cm) : Height: 6; Diameter of mouth: 17; Diameter of base: 6. Unearthed From : Collected By : Guan Baocong collection Date (AD) : late Published by : Lu Jing 2003, pl. 4-35.</p>	 <p>Cat. 872</p>
<p>Catalogue No. : Cat. 873 Type : Aa Body : Stoneware Glaze : white Decoration : Size (cm) : Height: 5.1; Diameter of mouth: 12.8; Diameter of base: 4.5. Unearthed From : Collected By : Guan Baocong collection Date (AD) : late Published by : Lu Jing 2003, pl. 4-38</p>	 <p>Cat. 873</p>

<p>Catalogue No. : Cat. 874 Type : Aa Body : Stoneware Glaze : white Decoration : Size (cm) : Height: 8.1; Diameter of mouth: 22; Diameter of base: 6.5. Unearthed From : Collected By : Guan Baocong collection Date (AD) : late Published by : Lu Jing 2003, pl. 4-53.</p>	 <p>Cat. 874</p>
<p>Catalogue No. : Cat. 875 Type : Aa Body : Stoneware Glaze : white Decoration : Size (cm) : Height: 6; Diameter of mouth: 15.9; Diameter of base: 5.7. Unearthed From : Collected By : Guan Baocong collection Date (AD) : late Published by : Lu Jing 2003, pl. 4-39.</p>	 <p>Cat. 875</p>
<p>Catalogue No. : Cat. 876 Type : Aa Body : Stoneware Glaze : white Decoration : Size (cm) : Height: 4.2; Diameter of mouth: 9.4; Diameter of base: 3. Unearthed From : Collected By : Guan Baocong collection Date (AD) : late Published by : Lu Jing 2003, pl. 4-46.</p>	 <p>Cat. 876</p>
<p>Catalogue No. : Cat. 877 Type : Aa Body : Stoneware Glaze : brown Decoration : Size (cm) : Height: 4; Diameter of mouth: 12. Unearthed From : XFJ Collected By : Date (AD) : 1072 Published by : Neimenggu wenwu kaogu yanjiusuo et al. 1994, 548-52.</p>	 <p>Cat. 877</p>

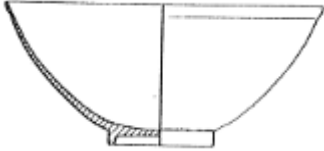
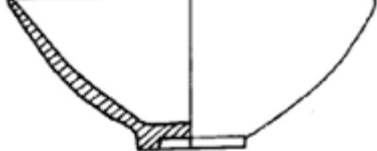

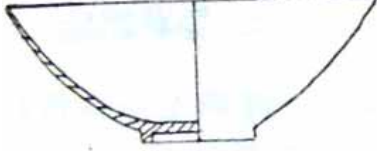

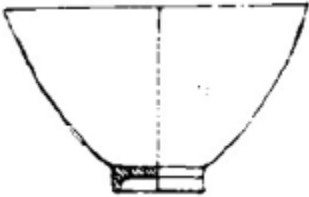
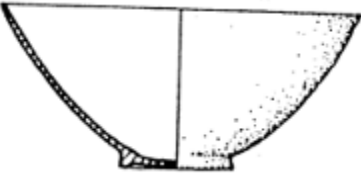
<p>Catalogue No. : Cat. 878 Type : Aa Body : Porcelain Glaze : white Decoration : Impressed floral designs in inner side Size (cm) : Height: 4.2; Diameter of mouth: 13; Diameter of base: 4. Unearthed From : Tomb at Kangjiazhangzi, Jianping city, Liaoning Province Collected By : Research institute of cultural relics and archaeology of Liaoning province Date (AD) : middle Published by : Lü Xueming 1997, 24-9, fig.7:8.</p>	 <p>Cat. 878</p>
<p>Catalogue No. : Cat. 879 Type : Aa Body : Stoneware Glaze : white Decoration : Size (cm) : Height: 3.6; Diameter of mouth: 10; Diameter of base: 3.4. Unearthed From : CDMM Collected By : Date (AD) : Published by : Wang Laizhu 1996, 66-8, fig.3:1.</p>	 <p>Cat. 879</p>
<p>Catalogue No. : Cat. 880 Type : Aa Body : Stoneware Glaze : white Decoration : Black rim Size (cm) : Height: 3.5; Diameter of mouth: 9.7; Diameter of base: 3.2. Unearthed From : Collected By : Liaoning Provincial Museum Date (AD) : late Published by : Liaoningsheng bowuguan 1961, pl. 9; Shanghai renmin meishu chubanshe 1986, pl. 32.</p>	 <p>Cat. 880</p>
<p>Catalogue No. : Cat. 881 Type : Aa Body : Porcelain Glaze : brown Decoration : With unglazed rim. Moulded designs of peony, lotus flower, plum flower and morning glory are adorned inside the bowls and moulded chrysanthemum designs at the bottom. Size (cm) : Height: 5.2-5.6; Diameter of mouth: 16.5-17.1; Diameter of base: 5.4. Unearthed From : A tomb at Shibeicun, Baiyinchang Township, Naiman Banner, Inner Mongolia Collected By : Tongliao Municipal Museum, Inner Mongolia Date (AD) : late Published by : Shanghai bowuguan 2000, pl. 178.</p>	 <p>Cat. 881</p>

<p>Catalogue No. : Cat. 882 Type : Aa Body : Stoneware Glaze : white Decoration : Carved floral designs Size (cm) : Height: 7.2; Diameter of mouth: 22.9. Unearthed From : Collected By : Liaoning Provincial Museum Date (AD) : late Published by : Shanghai renmin meishu chubanshe 1986, pl. 129.</p>	 <p>Cat. 882</p>
<p>Catalogue No. : Cat. 883 Type : Aa Body : Stoneware Glaze : white Decoration : Incised design Size (cm) : Height: 7.6; Diameter of mouth: 22.6; Diameter of base: 6.7. Unearthed From : Collected By : Liaoning Provincial Museum Date (AD) : late Published by : Liaoningsheng bowuguan 1961, pl. 95.</p>	 <p>Cat. 883</p>
<p>Catalogue No. : Cat. 884 Type : Aa Body : Porcelain Glaze : white Decoration : With "Guan" mark inscription Size (cm) : Height: 6; Diameter of mouth: 20.8. Unearthed From : YMT Collected By : Liaoning Provincial Museum Date (AD) : Published by : Shanhai renmin meishu chubanshe 1986, pl. 76.</p>	 <p>Cat. 884</p>
<p>Catalogue No. : Cat. 885 Type : Aa Body : Porcelain Glaze : white Decoration : Size (cm) : Height: 6; Diameter of mouth: 13.6; Diameter of base: 4.2. Unearthed From : Tomb of Xiao He at Fuxin city, Liaoning Province Collected By : Research institute of Cultrual relics and Archaeology of Liaoning Province Date (AD) : late Published by : Wan Xiongfei 2005,33-44, fig.10:2.</p>	 <p>Cat. 885</p>

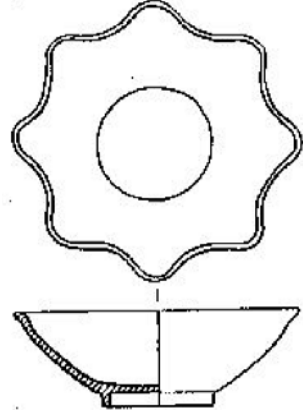

<p>Catalogue No. : Cat. 886 Type : Aa Body : Porcelain Glaze : green Decoration : Size (cm) : Height: 9.2; Diameter of mouth: 19.8. Unearthed From : XFJ Collected By : Date (AD) : 1072 Published by : Neimenggu wenwu kaogu yanjiusuo et al. 1994, 548-52, fig.3:3.</p>	 <p>Cat. 886</p>
<p>Catalogue No. : Cat. 887 Type : Aa Body : Stoneware Glaze : white Decoration : Size (cm) : Height: 4.8; Diameter of mouth: 12.3; Diameter of base: 3.6. Unearthed From : TJYZ Collected By : Date (AD) : late Published by : Zhao Guodong et al. 1997,68-72, fig.4:2.</p>	 <p>Cat. 887</p>
<p>Catalogue No. : Cat. 888 Type : Aa Body : Stoneware Glaze : white Decoration : Size (cm) : Height: 4.2; Diameter of mouth: 11.2. Unearthed From : CKTDS4 Collected By : Chifeng Municipal Museum, Inner Mongolia Date (AD) : late Published by : Liu Bing et al. 1998, 26-34, 38.</p>	 <p>Cat. 888</p>
<p>Catalogue No. : Cat. 889 Type : Aa Body : Porcelain Glaze : white Decoration : Size (cm) : Height: 5.4; Diameter of mouth: 14.4. Unearthed From : WFG Collected By : Date (AD) : late Published by : Sun Yutie 1998, 51-2, fig.3:8.</p>	 <p>Cat. 889</p>

<p>Catalogue No. : Cat. 890 Type : Aa Body : Porcelain Glaze : white Decoration : Size (cm) : Height: 6; Diameter of mouth: 10; Diameter of base: 3. Unearthed From : WFG Collected By : Date (AD) : late Published by : Sun Yutie 1998, 51-2, fig.3:7.</p>	 <p>Cat. 890</p>
<p>Catalogue No. : Cat. 891 Type : Aa Body : Stoneware Glaze : white Decoration : Size (cm) : Height: 5.5; Diameter of mouth: 12.6; Diameter of base: 4.2. Unearthed From : MJ1 Collected By : Date (AD) : late Published by : Wan Xin 1999, 15-23, fig.7:6.</p>	 <p>Cat. 891</p>
<p>Catalogue No. : Cat. 892 Type : Aa Body : Pinkish earthenware Glaze : green Decoration : Impressed floral designs in inner side Size (cm) : Height: 5.5. Unearthed From : JFYZ Collected By : Date (AD) : late Published by : Xiang Chunsong 1979, 330-34, fig.3:1.</p>	 <p>Cat. 892</p>

<p>Catalogue No. : Cat. 893 Type : Aa Body : Porcelain Glaze : white Decoration : Impressed floral designs in inner side Size (cm) : Height: 6; Diameter of mouth: 16.4; Diameter of base: 4.5. Unearthed From : Tomb of Xiao He at Fuxin City, Liaoning Province Collected By : Date (AD) : late Published by : Wan Xiongfei 2005, 33-44, fig.8.</p>	 <p>Cat. 893</p>
<p>Catalogue No. : Cat. 894 Type : Aa Body : Pinkish earthenware Glaze : yellow Decoration : Impressed floral designs in inner side Size (cm) : Height: 5.5; heigh: 12.8. Unearthed From : Collected By : Date (AD) : late Published by : Sugimura Yuzo 1974, pl. 56.</p>	 <p>Cat. 894</p>
<p>Catalogue No. : Cat. 895 Type : Aa Body : Pinkish earthenware Glaze : green Decoration : Impressed floral designs. Size (cm) : Height: 5.6; Diameter of mouth: 13.2. Unearthed From : JFYZ Collected By : Chifeng Municipal Museum Date (AD) : late Published by : Liaoningsheng bowuguan 1961, pl. 9; Shanghai renmin meishu chubanshe 1986, pl. 25.</p>	 <p>Cat. 895</p>
<p>Catalogue No. : Cat. 896 Type : Ab Body : Porcelain Glaze : white Decoration : Size (cm) : Height: 25.2. Unearthed From : ZLK Collected By : Date (AD) : early Published by : Feng Yongqian 1960, 15-24.</p>	 <p>Cat. 896</p>

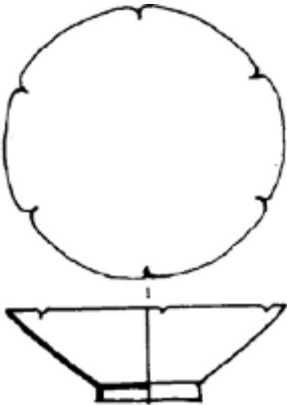
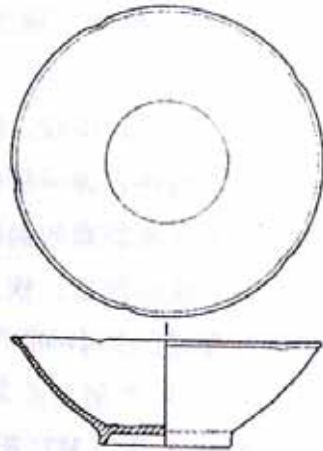
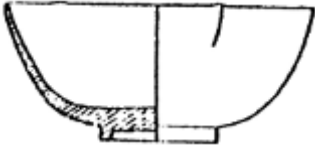

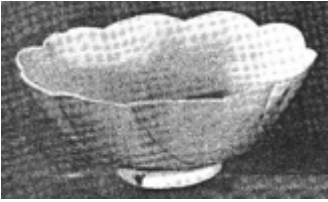
<p>Catalogue No. : Cat. 897 Type : Ab Body : Porcelain Glaze : white Decoration : Size (cm) : Height: 10; Diameter of mouth: 25.6; Diameter of base: 10. Unearthed From : YLYZ Collected By : Date (AD) : 942 Published by : Neimenggu wenwu kaogu yanjiusuo 1996, 4-32, fig.48:4.</p>	 <p>Cat. 897</p>
<p>Catalogue No. : Cat. 898 Type : Ab Body : Porcelain Glaze : white Decoration : Size (cm) : Height: 4.4; Diameter of mouth: 13; Diameter of base: 6. Unearthed From : HLB1 Collected By : Date (AD) : early Published by : Li Yufeng 1991, 106-19, fig.3:15.</p>	 <p>Cat. 898</p>
<p>Catalogue No. : Cat. 899 Type : Ab Body : Porcelain Glaze : white Decoration : Size (cm) : ? Unearthed From : XSC7 Collected By : Date (AD) : late Published by : Meng Jianren & Qian Yucheng 1994, 542-47, fig.3:2.</p>	 <p>Cat. 899</p>
<p>Catalogue No. : Cat. 900 Type : Ab Body : Pinkish earthenware Glaze : yellow Decoration : Impressed floral designs Size (cm) : Height: 7.6; Diameter of mouth: 18.7. Unearthed From : Collected By : Date (AD) : late Published by : Lu Jing 2003, pl. 3-494.</p>	 <p>Cat. 900</p>

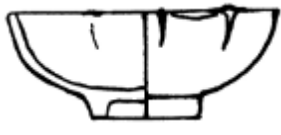
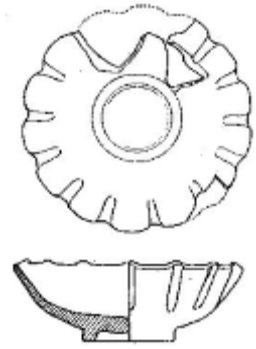

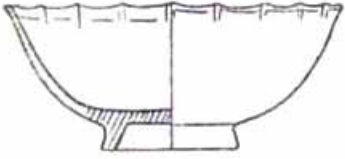
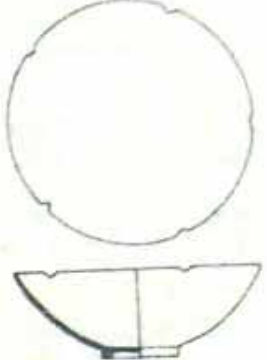
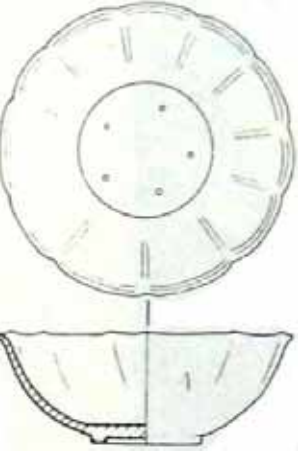
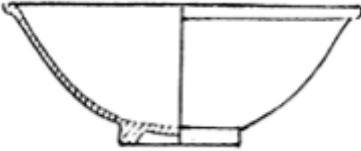
<p>Catalogue No. : Cat. 901 Type : Body : Gold Glaze : Decoration : Size (cm) : Height: 3.7; Diameter of mouth: 10.2. Unearthed From : Collected By : Inner Mongolia autonomous region museum Date (AD) : Xixia Published by : Zhang Jingming 2005, pl. 144.</p>	 <p>Cat. 901</p>
<p>Catalogue No. : Cat. 902 Type : Ab Body : Porcelain Glaze : white Decoration : Six lobed mouth Size (cm) : Height: 4; Diameter of mouth: 11.7; Diameter of base: 4. Unearthed From : YWG Collected By : Date (AD) : Middle Published by : Ma Qingpeng & Zhao Zhihou 1997, 47-49, fig.2:2.</p>	 <p>Cat. 902</p>
<p>Catalogue No. : Cat. 903 Type : Ab Body : Porcelain Glaze : white Decoration : Five lobed mouth Size (cm) : Height: 7.5; Diameter of mouth: 21.5; Diameter of base: 9.5. Unearthed From : Tomb at Chaoyanggou, Zhangwu city, Liaoning province Collected By : Relics office of Zhangwu city, Liaoning province Date (AD) : early Published by : Li Yufeng et al. 2003, 83-111, fig.26:6.</p>	 <p>Cat. 903</p>
<p>Catalogue No. : Cat. 904 Type : Ab Body : Porcelain Glaze : white Decoration : Size (cm) : Height: 4. Unearthed From : HYM Collected By : Date (AD) : 997 Published by : Huang Xiuchun et al. 1984, 361-81, fig.6:11.</p>	 <p>Cat. 904</p>

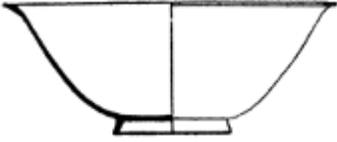
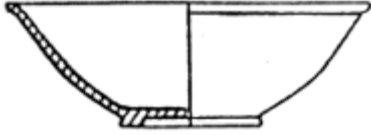
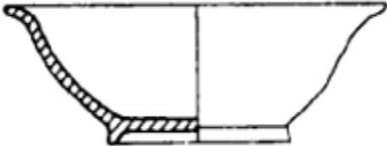
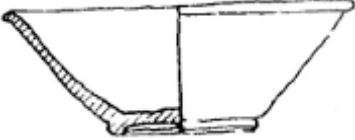
<p>Catalogue No. : Cat. 905 Type : Ab Body : Porcelain Glaze : white Decoration : Size (cm) : ? Unearthed From : WZM Collected By : Date (AD) : 1053 Published by : Beijingshi wenwu guanlichu 1972, 35-40.</p>	 <p>Cat. 905</p>
<p>Catalogue No. : Cat. 906 Type : Ab Body : Stoneware Glaze : white Decoration : Size (cm) : Height: 8.1; Diameter of mouth: 18.8; Diameter of base: 7.1. Unearthed From : Collected By : Guan Baocong collection Date (AD) : Published by : Lu Jing 2003, pl. 4-36.</p>	 <p>Cat. 906</p>
<p>Catalogue No. : Cat. 907 Type : Ab Body : Porcelain Glaze : white Decoration : Four lobed mouth Size (cm) : Height: 4; Diameter of mouth: 11; Diameter of base: 4. Unearthed From : PJG3 Collected By : Date (AD) : late Published by : Ji Ping 1997, 639-50, fig.7:5.</p>	 <p>Cat. 907</p>
<p>Catalogue No. : Cat. 908 Type : Ab Body : Porcelain Glaze : white Decoration : Fourteen lobed mouth Size (cm) : Height: 4.2; Diameter of mouth: 12.8. Unearthed From : Pagoda CYBTDG Collected By : Date (AD) : 1044 Published by : Dong Gao & Zhang Hongbo 1992, 1-28, fig.61.</p>	 <p>Cat. 908</p>

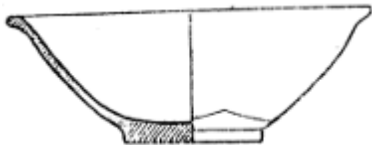
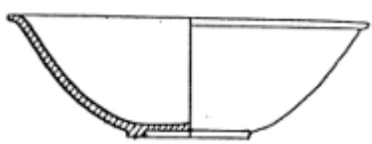

<p>Catalogue No. : Cat. 909 Type : Ab Body : Porcelain Glaze : white Decoration : Size (cm) : Height: 4; Diameter of mouth: 9.3. Unearthed From : CDM Collected By : Date (AD) : late Published by : Tian Li & Qi Xiaoguang 1986,77-79, fig.2:3.</p>	 <p>Cat. 909</p>
<p>Catalogue No. : Cat. 910 Type : Ab Body : Porcelain Glaze : white Decoration : Size (cm) : ? Unearthed From : GS1 Collected By : Date (AD) : late Published by : Jin Fengyi & Xu Ji 1985, 48-55, fig.7:6.</p>	 <p>Cat. 910</p>
<p>Catalogue No. : Cat. 911 Type : Ab Body : Porcelain Glaze : white Decoration : Size (cm) : ? Unearthed From : ZWZ Collected By : Date (AD) : 1093 Published by : Zheng Shaozong 1996, 14-46, fig.32:5 .</p>	 <p>Cat. 911</p>
<p>Catalogue No. : Cat. 912 Type : Ba Body : Porcelain Glaze : white Decoration : Size (cm) : Height: 6.8; Diameter of mouth: 18. Unearthed From : BS1 Collected By : Date (AD) : 923 Published by : Qi Xiaoguang et al. 1998, 73-95, fig.11:3.</p>	 <p>Cat. 912</p>

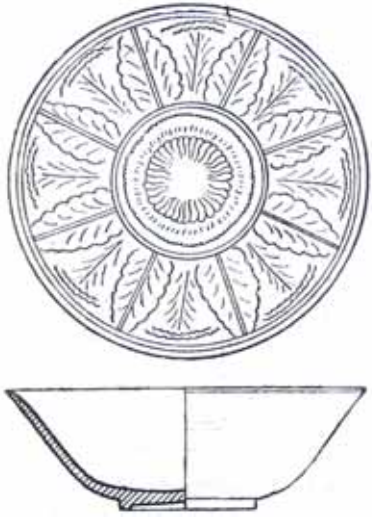
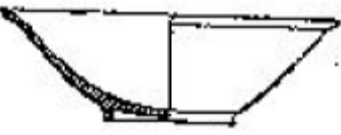
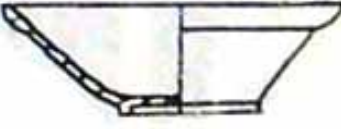
<p>Catalogue No. : Cat. 913 Type : Ba Body : Porcelain Glaze : white Decoration : Size (cm) : Height: 8; Diameter of mouth: 23; Diameter of base: 8.4. Unearthed From : SJG1 Collected By : Date (AD) : 1002 Published by : Deng Baoxue et al. 1983, 30-38, fig.12:1.</p>	 <p>Cat. 913</p>
<p>Catalogue No. : Cat. 914 Type : Ba Body : Stoneware Glaze : white Decoration : Size (cm) : Height: 8; Diameter of mouth: 20.8; Diameter of base: 7.2. Unearthed From : ABEGE Collected By : Date (AD) : early Published by : Neimenggu wenwu kaogu yanjiusuo,1994a.</p>	 <p>Cat. 914</p>
<p>Catalogue No. : Cat. 915 Type : Ba Body : Stoneware Glaze : white Decoration : Size (cm) : Height: 6.4; Diameter of mouth: 17.4; Diameter of base: 8.2. Unearthed From : YMT22 Collected By : Date (AD) : middle Published by : Xu Zhiguo & Wei Chunguang 2000, 48-51, fig.3.</p>	 <p>Cat. 915</p>
<p>Catalogue No. : Cat. 916 Type : Ba Body : Stoneware Glaze : white Decoration : Size (cm) : Height: 5.2; Diameter of mouth: 18.6; Diameter of base: 7.2. Unearthed From : ZJY1 Collected By : Date (AD) : early Published by : Pei Yaojun 1996, 57-62, fig.3:5.</p>	 <p>Cat. 916</p>

<p>Catalogue No. : Cat. 917 Type : Ba Body : Stoneware Glaze : white Decoration : Size (cm) : Height: 7.2; Diameter of mouth: 21.3; Diameter of base: 6.3. Unearthed From : Collected By : Guan Baocong collection Date (AD) : Published by : Lu Jing 2003, pl. 3-482.</p>	 <p>Cat. 917</p>
<p>Catalogue No. : Cat. 918 Type : Ba Body : Pinkish earthenware Glaze : green Decoration : Black rim Size (cm) : Height: 8.5; Diameter of mouth: 19.5 Unearthed From : XDM Collected By : Chifeng Municipal Museum Date (AD) : late Published by : Shanhai renmin meishu chubanshe 1986, pl. 18.</p>	 <p>Cat. 918</p>
<p>Catalogue No. : Cat. 919 Type : Ba Body : Stoneware Glaze : white Decoration : Size (cm) : Height: 7.2; Diameter of mouth: 20.7; Diameter of base: 7.8. Unearthed From : BL4 Collected By : Date (AD) : middle Published by : Wu Jiachang 1986, 32-51, fig.21:3.</p>	 <p>Cat. 919</p>
<p>Catalogue No. : Cat. 920 Type : Ba Body : Stoneware Glaze : white Decoration : Size (cm) : Height: 8.6; Diameter of mouth: 24; Diameter of base: 8. Unearthed From : XSC9 Collected By : Date (AD) : late Published by : Meng Jianren & Qian Yucheng 1994, 542-547, fig.3:5.</p>	 <p>Cat. 920</p>

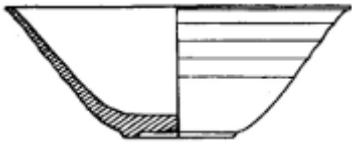
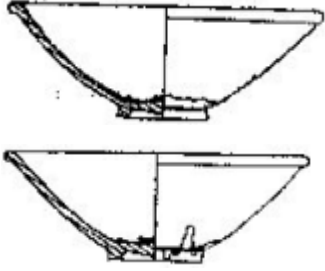
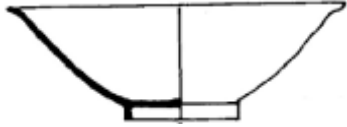

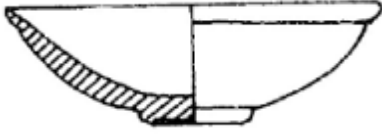
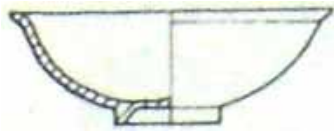
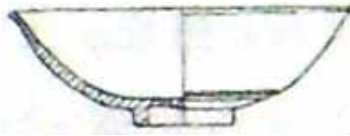
<p>Catalogue No. : Cat. 921 Type : Ba Body : Porcelain Glaze : white Decoration : Impressed floral designs Size (cm) : Height: 6.5; Diameter of mouth: 19.5. Unearthed From : HQYZ6 Collected By : Date (AD) : late Published by : Wumeng wenwu gongzuozhan 1985, 7-44, fig.17.</p>	 <p>Cat. 921</p>
<p>Catalogue No. : Cat. 922 Type : Ba Body : Stoneware Glaze : white Decoration : Size (cm) : Height: 7.5; Diameter of mouth: 23.7. Unearthed From : BTZ Collected By : Date (AD) : late Published by : Shao Guotian 1978, 119-21, fig.4:7.</p>	 <p>Cat. 922</p>
<p>Catalogue No. : Cat. 923 Type : Ba Body : Stoneware Glaze : white Decoration : Size (cm) : Height: 4; Diameter of mouth: 12.8; Diameter of base: 5. Unearthed From : WJF Collected By : Date (AD) : early Published by : Wang Gang & Lü Qing 2001, 124-26, fig.3:7..</p>	 <p>Cat. 923</p>
<p>Catalogue No. : Cat. 924 Type : Ba Body : Stoneware Glaze : white Decoration : Size (cm) : Height: 4.5; Diameter of mouth: 15; Diameter of base: 5.4. Unearthed From : FJTGX Collected By : Date (AD) : late Published by : Aluke'erqin qi wenguansuo et al. 1996, 78-81, fig.4:5.</p>	 <p>Cat. 924</p>

<p>Catalogue No. : Cat. 925 Type : Ba Body : Pinkish earthenware Glaze : yellow Decoration : Size (cm) : Height: 7.6; Diameter of mouth: 23.5; Diameter of base: 8. Unearthed From : Tomb at Nanhuang, Nanta Township, Aohan Banner, Inner Mongolia Collected By : Aohan Banner Museum, Inner Mongolia Date (AD) : late Published by : Shao Guotian ed. 2004, pl. 151.</p>	 <p>Cat. 925</p>
<p>Catalogue No. : Cat. 926 Type : Ba Body : Stoneware Glaze : white Decoration : Size (cm) : Height: 8.4; Diameter of mouth: 20.8; Diameter of base: 6.3. Unearthed From : YS1 Collected By : Date (AD) : late Published by : Shao Guotian et al. 1999, 1-38,43, fig.9:3.</p>	 <p>Cat. 926</p>
<p>Catalogue No. : Cat. 927 Type : Ba Body : Stoneware Glaze : white Decoration : Size (cm) : ? Unearthed From : WLHD Collected By : Date (AD) : late Published by : Wang Jianguo & Ma Junshan 1986, 74-76, fig.3:2,3.</p>	 <p>Cat. 927</p>
<p>Catalogue No. : Cat. 928 Type : Ba Body : Stoneware Glaze : white Decoration : Size (cm) : Height: 8.5; Diameter of mouth: 22; Diameter of base: 8. Unearthed From : YWG Collected By : Date (AD) : Middle Published by : Ma Qingpeng & Zhao Zhihou 1997, 47-49, fig.2:3.</p>	 <p>Cat. 928</p>

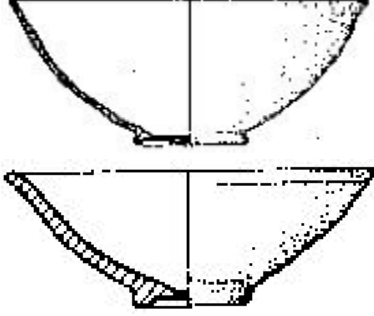
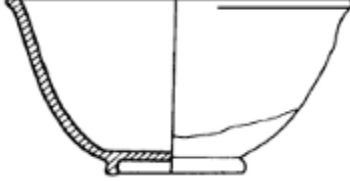
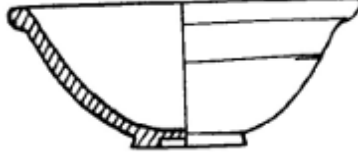
<p>Catalogue No. : Cat. 929 Type : Ba Body : Stoneware Glaze : white Decoration : Size (cm) : ? Unearthed From : CDMM Collected By : Date (AD) : late Published by : Wang Laizhu 1996, 66-8, fig.3:2.</p>	 <p>Cat. 929</p>
<p>Catalogue No. : Cat. 930 Type : Ba Body : Stoneware Glaze : white Decoration : Size (cm) : Height: 4; Diameter of mouth: 11.3. Unearthed From : ZWZ Collected By : Date (AD) : 1093 Published by : Zheng Shaozong 1996, 14-46, fig.32:3.</p>	 <p>Cat. 930</p>
<p>Catalogue No. : Cat. 931 Type : Ba Body : Stoneware Glaze : white Decoration : Size (cm) : Height: 7.2; Diameter of mouth: 21.3; Diameter of base: 6.2. Unearthed From : Tomb at Sijiazi, Fuxin city, Liaoning Province Collected By : Date (AD) : late Published by : Liang Zhenjing 2003, 121-9, fig. 4:5.</p>	 <p>Cat. 931</p>
<p>Catalogue No. : Cat. 932 Type : Ba Body : Stoneware Glaze : white Decoration : Size (cm) : Height: 7; Diameter of mouth: 18.8; Diameter of base: 2.8. Unearthed From : Tomb at Sijiazi, Fuxin city, Liaoning Province Collected By : Date (AD) : late Published by : Liang Zhenjing 2003, 121-9, fig.4:4.</p>	 <p>Cat. 932</p>

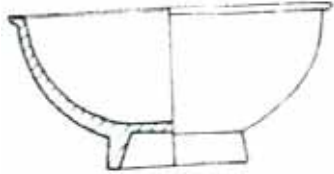
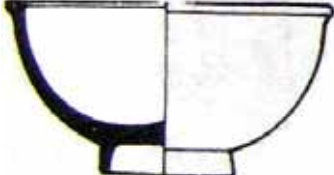
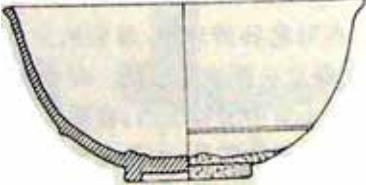
<p>Catalogue No. : Cat. 933 Type : Ba Body : Stoneware Glaze : white Decoration : Size (cm) : Height: 6.5-7.5; Diameter of mouth: 18-24. Unearthed From : KL6 Collected By : Date (AD) : late Published by : Zhelimumeng bowuguan et al. 1982, 35-46, 28, fig.9:9.</p>	 <p>Cat. 933</p>
<p>Catalogue No. : Cat. 934 Type : Ba Body : Stoneware Glaze : white Decoration : Size (cm) : Height: 5.5; Diameter of mouth: 12.6; Diameter of base: 4.2.. Unearthed From : MJ1 Collected By : Date (AD) : late Published by : Wan Xin 1999, 15-23, fig.7:8,1.</p>	 <p>Cat. 934</p>
<p>Catalogue No. : Cat. 935 Type : Ba Body : Pinkish earthenware Glaze : green Decoration : Size (cm) : Height: 11.8; Diameter of mouth: 21; Diameter of base: 8. Unearthed From : XHD Collected By : Date (AD) : late Published by : Wang Gang 1998, 44-9, fig.3,4.</p>	 <p>Cat. 935</p>
<p>Catalogue No. : Cat. 936 Type : Ba Body : Pinkish earthenware Glaze : yellow Decoration : Size (cm) : Height: 8; Diameter of mouth: 19.5. Unearthed From : FJTGX Collected By : Date (AD) : late Published by : Aluke'erqin qi wenguansuo et al. 1996, 78-81, fig.4:1.</p>	 <p>Cat. 936</p>

<p>Catalogue No. : Cat. 937 Type : Ba Body : Pinkish earthenware Glaze : yellow Decoration : Size (cm) : ? Unearthed From : ZKZ Collected By : Date (AD) : 1093 Published by : Liu Haiwen et al. 1995. Hebeisheng wenwu guanlichu et al.1975, 31-39.</p>	 <p>Cat. 937</p>
<p>Catalogue No. : Cat. 938 Type : Ba Body : Pinkish earthenware Glaze : yellow Decoration : Size (cm) : Height: 7.8; Diameter of mouth: 16. Unearthed From : ZWZ Collected By : Date (AD) : 1093 Published by : Zheng Shaozong 1996, 14-46, fig.21:4.</p>	 <p>Cat. 938</p>
<p>Catalogue No. : Cat. 938 Type : Ba Body : Pinkish earthenware Glaze : yellow Decoration : Size (cm) : Height: 7.8; Diameter of mouth: 16.2. Unearthed From : ZWZ Collected By : Date (AD) : 1115-1144 Published by : Tao Zongyi et al. 1-19, fig.27:3..</p>	 <p>Cat. 939</p>
<p>Catalogue No. : Cat. 940 Type : Ba Body : Stoneware Glaze : white Decoration : Size (cm) : Height: 11.8; Diameter of mouth: 21. Unearthed From : BTYZ Collected By : Date (AD) : late Published by : Feng Yongqian 1960, 15-24, fig.9:7.</p>	 <p>Cat. 940</p>

<p>Catalogue No. : Cat. 941 Type : Ba Body : Pinkish earthenware Glaze : Three-colored Decoration : Impressed floral designs Size (cm) : Diameter of mouth: 15.1. Unearthed From : Collected By : Date (AD) : late Published by : Sugimura Yuzo 1974, pl. 74.</p>	 <p>Cat. 941</p>
<p>Catalogue No. : Cat. 942 Type : Ba Body : Pinkish earthenware Glaze : yellow Decoration : Size (cm) : Height: 7.6; Diameter of mouth: 19.5; Diameter of base: 6.8. Unearthed From : Collected By : Guan Baocong collection Date (AD) : late Published by : Lu Jing 2003, pl. 3-486.</p>	 <p>Cat. 942</p>
<p>Catalogue No. : Cat. 944 Type : Ba Body : Pinkish earthenware Glaze : green Decoration : Size (cm) : Diameter of mouth: 13. Unearthed From : Collected By : Date (AD) : late Published by : Sugimura Yuzo 1974, pl. 54.</p>	 <p>Cat. 943</p>

Catalogue No. : Cat. 945
 Type : Bb
 Body : Stoneware
 Glaze : white
 Decoration : Five lobed mouth
 Size (cm) : Height: 7.3; Diameter of mouth: 5;
 Diameter of base: 6.9.
 Unearthed From : GMZ
 Collected By :
 Date (AD) : late
 Published by : Li Dajun 1997, 30-6, fig.7:6.

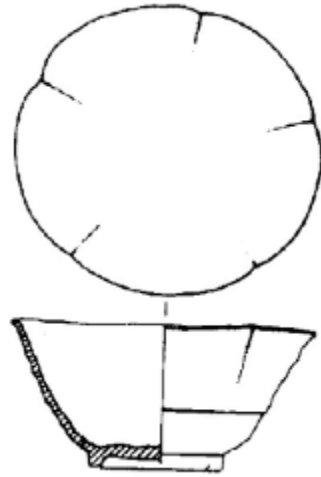

Cat. 944

Catalogue No. : Cat. 945
 Type : Bb
 Body : Porcelain
 Glaze : white
 Decoration : Five lobed mouth
 Size (cm) : Height: 4; Diameter of mouth: 8.7;
 Diameter of base: 3.6.
 Unearthed From : HLDT2
 Collected By :
 Date (AD) : early
 Published by : Zhang Shaoqing 1988, 819-24, fig.3:1.

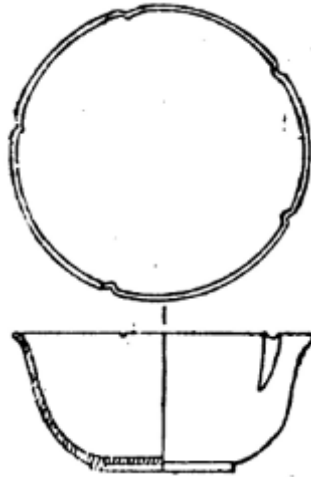



Cat. 945

Catalogue No. : Cat. 946
 Type : Bb
 Body : Porcelain
 Glaze : white
 Decoration : Six lobed mouth
 Size (cm) : Height: 4; Diameter of mouth: 8.4.
 Unearthed From : BL4
 Collected By :
 Date (AD) : Middle
 Published by : Wu Jiachang 1986, 32-51, fig.21:1.

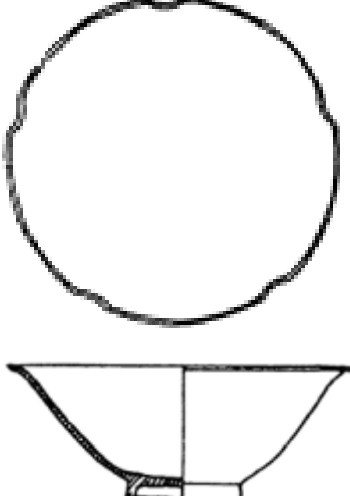

Cat. 946

<p>Catalogue No. : Cat. 947 Type : Bb Body : Porcelain Glaze : white Decoration : Six lobed mouth Size (cm) : Height: 10.1-10.8; Diameter of mouth: 4-4.9. Unearthed From : YLYN Collected By : Date (AD) : 986 Published by : Liaoningsheng bowuguan wenwu gongzuodui 1980, 18-22.</p>	 <p>Cat. 947</p>
<p>Catalogue No. : Cat. 948 Type : Bb Body : Porcelain Glaze : white Decoration : Six lobed mouth Size (cm) : Height: 7; Diameter of mouth: 21.9. Unearthed From : CGB11 Collected By : Date (AD) : Middle Published by : Dong Wenyi 1984, 91-93, fig 2:3.</p>	 <p>Cat. 948</p>
<p>Catalogue No. : Cat. 949 Type : Bb Body : Porcelain Glaze : white Decoration : Six lobed mouth Size (cm) : Height: 9; Diameter of mouth: 24.5. Unearthed From : QCH Collected By : Date (AD) : middle Published by : Jin Fengyi 1980, 17-29, fig.5.</p>	 <p>Cat. 949</p>

Catalogue No. : Cat. 950
 Type : Bb
 Body : Porcelain
 Glaze : white
 Decoration : Six lobed mouth
 Size (cm) : Height: 3.6; Diameter of mouth: 11.
 Unearthed From : ZGY
 Collected By :
 Date (AD) : 1117
 Published by : Tao Zongyi et al. 1990, 1-19, fig.10:8.

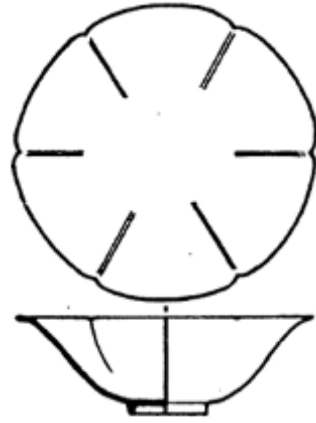

Cat. 950

Catalogue No. : Cat. 951
 Type : Bb
 Body : Porcelain
 Glaze : white
 Decoration : Six lobed mouth
 Size (cm) : Height: 5.6; Diameter of mouth: 15.8.
 Unearthed From : ZWZ
 Collected By :
 Date (AD) : 1093
 Published by : Zheng Shaozong 1996, 14-46, fig.32:4.

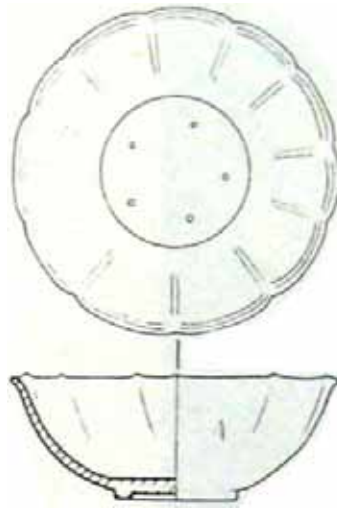



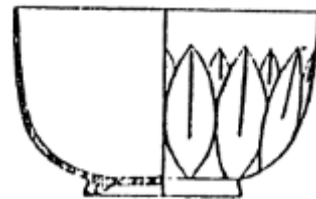

Cat. 951



Catalogue No. : Cat. 952
 Type : Ca
 Body : Stoneware
 Glaze : white
 Decoration : With carved lotus petals design.
 Size (cm) : Height: 10.4; Diameter of mouth: 18;
 Diameter of base: 9.2.
 Unearthed From : SJG1
 Collected By :
 Date (AD) : 1002
 Published by : Deng Baoxue et al. 1983, 30-38.

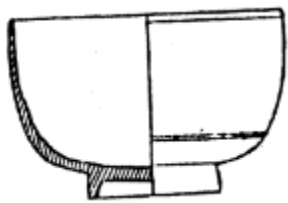

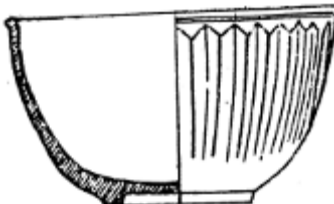
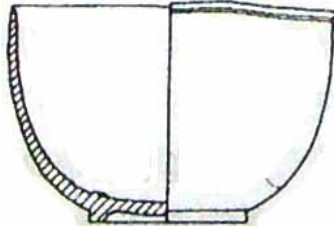

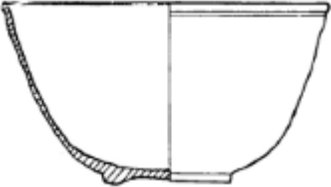

Cat. 952

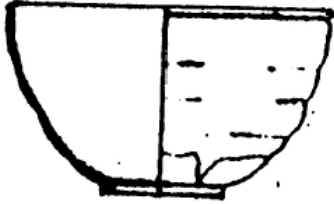

<p>Catalogue No. : Cat. 953 Type : Ca Body : Stoneware Glaze : white Decoration : With carved lotus petals design. Size (cm) : Height: 11.6; Diameter of mouth: 14.2; Diameter of base: 6.9. Unearthed From : Collected By : Liaoning Provincial Museum Date (AD) : late Published by : Shanghai renmin meishu chubanshe 1986, pl. 98; Liaoningsheng bowuguan 1961, pl. 100.</p>	 <p>Cat. 953</p>
<p>Catalogue No. : Cat. 954 Type : Ca Body : Stoneware Glaze : white Decoration : With carved crossed lines design. Size (cm) : Height: 5; Diameter of mouth: 9.2. Unearthed From : Collected By : Guan Baocon collection Date (AD) : Published by : Lu Jing 2003, pl. 3-504.</p>	 <p>Cat. 954</p>
<p>Catalogue No. : Cat. 955 Type : Ca Body : Stoneware Glaze : white Decoration : With carved lotus petals design. Size (cm) : Height: 8.8; Diameter of mouth: 15.2; Diameter of base: 8. Unearthed From : Collected By : Guan Baocon collection Date (AD) : Published by : Lu Jing 2003, pl. 3-500.</p>	 <p>Cat. 955</p>
<p>Catalogue No. : Cat. 956 Type : Ca Body : Pinkish earthenware Glaze : yellow Decoration : Size (cm) : Diameter of mouth: 11. Unearthed From : JFYZ Collected By : Date (AD) : late Published by : Xiang Chunsong 1979, 330-34, fig.3:9.</p>	 <p>Cat. 956</p>

<p>Catalogue No. : Cat. 957 Type : Ca Body : Stoneware Glaze : white Decoration : Size (cm) : Height: 10.4; Diameter of mouth: 17.7; Diameter of base: 7.9. Unearthed From : BL4 Collected By : Date (AD) : Middle Published by : Wu Jiachang 1986, 32-51, fig.21:2.</p>	 <p>Cat. 957</p>
<p>Catalogue No. : Cat. 958 Type : Ca Body : Stoneware Glaze : white Decoration : Size (cm) : Height: 12.8; Diameter of mouth: 20; Diameter of base: 9.5. Unearthed From : Tomb at Chaoyanggou, Zhangwu City, Liaoning Province (M3:3) Collected By : Relics office of Zhangwu city, Liaoning Province Date (AD) : early Published by : Li Yufeng et al. 2003, 83-111, fig.32:4.</p>	 <p>Cat. 958</p>
<p>Catalogue No. : Cat. 959 Type : Ca Body : Stoneware Glaze : brown Decoration : Size (cm) : Height: 14 Unearthed From : LQW kiln site Collected By : Date (AD) : late Published by : Beijingshi wenwu yanjiusuo 2002, pl.4:2.</p>	 <p>Cat. 959</p>
<p>Catalogue No. : Cat. 960 Type : Ca Body : Stoneware Glaze : white Decoration : Size (cm) : Height: 13.5 Unearthed From : LQW kiln site Collected By : Date (AD) : late Published by : Beijingshi wenwu yanjiusuo 2002, pl.5:2.</p>	 <p>Cat. 960</p>

<p>Catalogue No. : Cat. 961 Type : Ca Body : Stoneware Glaze : white Decoration : Size (cm) : Height: 10.6; Diameter of mouth: 19.2; Diameter of base: 7.2. Unearthed From : A tomb at Chenggou, Fuxin City, Liaoning Province Collected By : Fuxin Municipal Museum Date (AD) : late Published by : Hu Jian et al. 1998, 25-28.</p>	 <p>Cat. 961</p>
<p>Catalogue No. : Cat. 962 Type : Ca Body : Stoneware Glaze : white Decoration : Carved lotus petals leaved Size (cm) : Height: 10.8; Diameter of mouth: 17.6; Diameter of base: 7.6. Unearthed From : Tomb at Kangjiazhangzi, Jianping City, Inner Mongolia Collected By : Research institute of cultural relics and archaeology of Liaoning Province Date (AD) : late Published by : Lü Xueming 1997, 24-9, fig.4:2.</p>	 <p>Cat. 962</p>
<p>Catalogue No. : Cat. 963 Type : Ca Body : Stoneware Glaze : white Decoration : With black rim. Size (cm) : Diameter of mouth: 16. Unearthed From : Collected By : Date (AD) : late Published by : Mok 1985, pl. 15.</p>	 <p>Cat. 963</p>
<p>Catalogue No. : Cat. 964 Type : Ca Body : Stoneware Glaze : white Decoration :. Size (cm) : Diameter of mouth: 16. Unearthed From : GS1 Collected By : Date (AD) : late Published by : Jin Fengyi & Xu Ji 1985, 48-55, fig.7:7.</p>	 <p>Cat. 964</p>



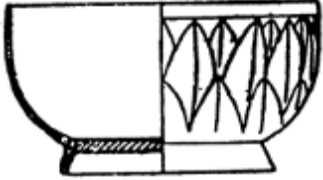

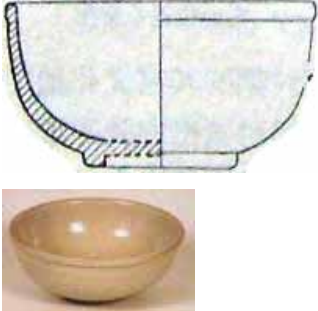
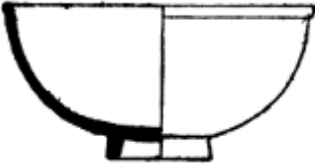
<p>Catalogue No. : Cat. 965 Type : Ca Body : Stoneware Glaze : white Decoration : Size (cm) : Height: 10; Diameter of mouth: 18.4. Unearthed From : FZZ Collected By : Date (AD) : late Published by : Ta La & Yiyou 1984, 75-9, fig.3:2.</p>	 <p>Cat. 965</p>
<p>Catalogue No. : Cat. 966 Type : Ca Body : Stoneware Glaze : white Decoration : With black rim. Size (cm) : Height: 8.4; Diameter of mouth: 14.5; Diameter of base: 5.5. Unearthed From : Collected By : Date (AD) : late Published by : Lu Jing 2003, pl. 4-45.</p>	 <p>Cat. 966</p>
<p>Catalogue No. : Cat. 967 Type : Ca Body : Stoneware Glaze : brown Decoration : Size (cm) : Height: 8.5; Diameter of mouth: 11.2; Diameter of base: 3.5. Unearthed From : Tomb at Sidaowanzi Township, Aohan Banner, Inner Mongolia Collected By : Aohan Banner Museum, Inner Mongolia Date (AD) : Published by : Shao Guotian 2004, pl. 150.</p>	 <p>Cat. 967</p>
<p>Catalogue No. : Cat. 968 Type : Ca Body : Stoneware Glaze : white Decoration : Size (cm) : Height: 10; Diameter of mouth: 18.5; Diameter of base: 7.5. Unearthed From : GTT kiln site Collected By : Guan Baocong collection Date (AD) : late Published by : Lu Jing 2003, pl. 4-48.</p>	 <p>Cat. 968</p>



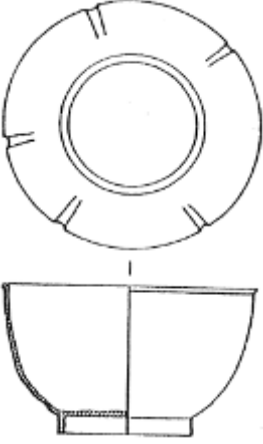
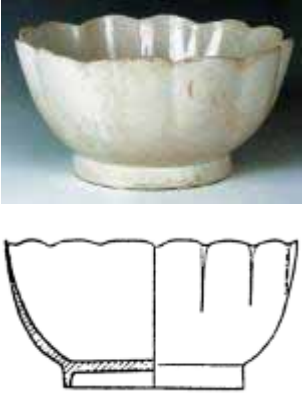
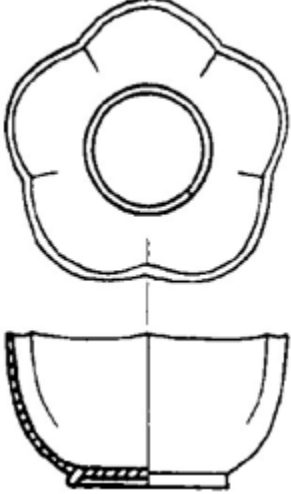

<p>Catalogue No. : Cat. 969 Type : Ca Body : Stoneware Glaze : white Decoration : Size (cm) : Height: 11.3; Diameter of mouth: 17.7; Diameter of base: 7.5. Unearthed From : GTT kiln site Collected By : Guan Baocong collection Date (AD) : late Published by : Lu Jing 2003, pl. 4-48.</p>	 <p>Cat. 969</p>
<p>Catalogue No. : Cat. 970 Type : Ca Body : Stoneware Glaze : white Decoration : Size (cm) : Height: 11.5; Diameter of mouth: 19.1; Diameter of base: 9.2. Unearthed From : Collected By : Liaoning Provincial Museum Date (AD) : late Published by : Shanghai renmin meishu chubanshe 1986, pl. 98; Liaoningsheng bowuguan 1961, pl. 99.</p>	 <p>Cat. 970</p>
<p>Catalogue No. : Cat. 971 Type : Ca Body : Stoneware Glaze : white Decoration : With black rim. Size (cm) : Height: 9.1; Diameter of mouth: 16; Diameter of base: 6.8. Unearthed From : Collected By : Liaoning Provincial Museum Date (AD) : late Published by : Shanghai renmin meishu chubanshe 1986, pl. 98; Liaoningsheng bowuguan 1961, pl. 98.</p>	 <p>Cat. 971</p>
<p>Catalogue No. : Cat. 972 Type : Ca Body : Porcelain Glaze : white Decoration : With GUAN mark inscription Size (cm) : Diameter of mouth: 15.2. Unearthed From : Collected By : Date (AD) : early Published by : Sugimura Yuzo 1974, pl. 58.</p>	 <p>Cat. 972</p>

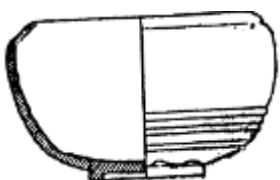
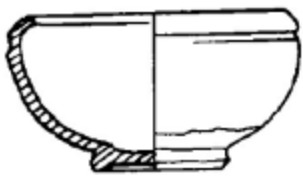
<p>Catalogue No. : Cat. 973 Type : Ca Body : Stoneware Glaze : white Decoration : Carved lotus petals leaved Size (cm) : Height: 7.5; Diameter of mouth: 14. Unearthed From : BL1 Collected By : Liaoning Provincial Museum Date (AD) : Middle Published by : Wu Jiachang 1986, 32-51, fig.4:2.</p>	 Cat. 973
<p>Catalogue No. : Cat. 974 Type : Ca Body : Porcelain Glaze : white Decoration : Size (cm) : Height: 7; Diameter of mouth: 15.5; Diameter of base: 7.4. Unearthed From : GZX Collected By : Date (AD) : 1027 Published by : Zhu Zifang & Xu Ji 1983, 168-195, fig.4:7.</p>	 Cat. 974
<p>Catalogue No. : Cat. 975 Type : Ca Body : Stoneware Glaze : white Decoration : Size (cm) : Diameter of mouth: 18.6; Diameter of base: 7.1. Unearthed From : GWYC kiln site Collected By : Guan Baocong collection Date (AD) : late Published by : Lu Jing 2003, pl. 4-41; Jia Zhoujie 1973, 241-3, fig.5:2.</p>	 Cat. 975
<p>Catalogue No. : Cat. 976 Type : Ca Body : Pinkish earthenware Glaze : yellow Decoration : Size (cm) : Height: 10.8. Unearthed From : BL3 Collected By : Date (AD) : late Published by : Wu Jiachang 1986, 32-51, fig.16:2.</p>	 Cat. 976





<p>Catalogue No. : Cat. 977 Type : Ca Body : Pinkish earthenware Glaze : white Decoration : Size (cm) : Height: 7.1; Diameter of mouth: 16.2; Diameter of base: 6.4. Unearthed From : Collected By : Guan Baocong collection Date (AD) : late Published by : Lu Jing 2003, pl. 4-47.</p>	 <p>Cat. 977</p>
<p>Catalogue No. : Cat. 978 Type : Ba Body : Pinkish earthenware Glaze : yellow Decoration : Moulded peony designs Size (cm) : Height: 5.5; Diameter of mouth: 15.1; Diameter of base: 6. Unearthed From : Collected By : Liaoning Provincial Museum Date (AD) : late Published by : Liaoningsheng bowuguan 1961, pl. 94.</p>	 <p>Cat. 978</p>
<p>Catalogue No. : Cat. 979 Type : Ca Body : Pinkish earthenware Glaze : yellow Decoration : Impressed floral designs Size (cm) : Height: 8.5; Diameter of mouth: 18.9; Diameter of base: 6.2. Unearthed From : Collected By : Guan Baocong collection Date (AD) : late Published by : Lu Jing 2003, pl. 4-129.</p>	 <p>Cat. 979</p>
<p>Catalogue No. : Cat. 980 Type : Ca Body : Pinkish earthenware Glaze : yellow Decoration : Size (cm) : Height: 8.7; Diameter of mouth: 18.8; Diameter of base: 5.8. Unearthed From : Collected By : Guan Baocong collection Date (AD) : late Published by : Lu Jing 2003, pl. 4-128.</p>	 <p>Cat. 980</p>



<p>Catalogue No. : Cat. 981 Type : Cb Body : Stoneware Glaze : green Decoration : Size (cm) : Height: 11; Diameter of Mouth: 17.5; Diameter of base: 10. Unearthed From : DQTL3 Collected By : Date (AD) : early Published by : Meng Jianren & Piao Chunyue 1997, 651-67, fig.10:5.</p>	 <p>Cat. 981</p>
<p>Catalogue No. : Cat. 982 Type : Cb Body : Porcelain Glaze : white Decoration : Size (cm) : Height: 7.7; Diameter of mouth: 14.8; Diameter of base: 9. Unearthed From : CGGZ Collected By : Research institute of cultural relics and archaeology of Inner Mongolia Date (AD) : 1018 Published by : Neimenggu zizhiqiu wenhuating & Zhongguo lishi bowuguan 2002, pl. 250; Neimenggu wenwu kaogu yanjiusuo et al. 1993, 53, fig.32:7.</p>	 <p>Cat. 982</p>
<p>Catalogue No. : Cat. 983 Type : Cb Body : Pinkish earthenware Glaze : green Decoration : Size (cm) : Height: 9.4; Diameter of mouth: 17; Diameter of base: 9.3. Unearthed From : YMT22 Collected By : Date (AD) : middle Published by : Xu Zhiguo & Wei Chunguang 2000, 48-51, fig.3:9.</p>	 <p>Cat. 983</p>

<p>Catalogue No. : Cat. 984 Type : D Body : Pinkish earthenware Glaze : yellow Decoration : Size (cm) : Height: 11.6; Diameter of mouth: 16.2; Diameter of base: 8.6. Unearthed From : DSLT1 Collected By : Date (AD) : Middle Published by : Wan Xin 1999, 15-23.</p>	 <p>Cat. 984</p>
<p>Catalogue No. : Cat. 985 Type : D Body : Pinkish earthenware Glaze : yellow Decoration : Size (cm) : Height: 10.6; Diameter of mouth: 14.6. Unearthed From : JFYZ Collected By : Chifeng Municipal Museum, Inner Mongolia Date (AD) : late Published by : Shanghai renmin meishu chubanshe, 1986, pl. 155; Xiang Chunsong 1979, 330-4, fig.3:10.</p>	  <p>Cat. 985</p>
<p>Catalogue No. : Cat. 986 Type : D Body : Pinkish earthenware Glaze : green Decoration : Size (cm) : Height: 7.5; Diameter of mouth: 11. Unearthed From : A tomb at Xinlincun, Xianfeng township, Aluke'erqin Banner, Inner Mongolia Collected By : Date (AD) : late Published by : Aluke'erqin qi wenguansuo et al. 1996, 78-81, fig.2:3.</p>	 <p>Cat. 986</p>
<p>Catalogue No. : Cat. 987 Type : D Body : Pinkish earthenware Glaze : yellow Decoration : Size (cm) : Height: 10-13; Diameter of mouth: 15.8-18. Unearthed From : XLZZ1 Collected By : Date (AD) : late Published by : Li Yiyou 1961, 44-9, fig.9.</p>	 <p>Cat. 987</p>

<p>Catalogue No. : Cat. 988 Type : D Body : Pinkish earthenware Glaze : white Decoration : Size (cm) : Height: 5; Diameter of mouth: 10.6; Diameter of base: 4.3. Unearthed From : ZDB Collected By : Date (AD) : early Published by : Chaoyangshi bowuguan 2004, 64-66.</p>	 <p>Cat. 988</p>
<p>Catalogue No. : Cat. 989 Type : D Body : Pinkish earthenware Glaze : yellow Decoration : Size (cm) : Height: 5.6; Diameter of mouth: 10. Unearthed From : BL3 Collected By : Date (AD) : late Published by : Wu Jiachang 1986, 32-51, fig.16:1.</p>	 <p>Cat. 989</p>
<p>Catalogue No. : Cat. 990 Type : D Body : Stoneware Glaze : white Decoration : Size (cm) : Height: 13 Diameter of mouth: 10; Diameter of base: 7. Unearthed From : A tomb at Laopogou, Linjiadi Township, Aohan Banner, Inner Mongolia Collected By : Aohan Banner Museum, Inner Mongolia Date (AD) : late Published by : Shao Guotian 2004, pl. 145-3.</p>	 <p>Cat. 990</p>
<p>Catalogue No. : Cat. 991 Type : D Body : Stoneware Glaze : white Decoration : Size (cm) : Diameter of mouth: 15.5. Unearthed From : Collected By : Buffalo Museum of Science, New York Date (AD) : early Published by : Watson 1984, pl. 293.</p>	 <p>Cat. 991</p>

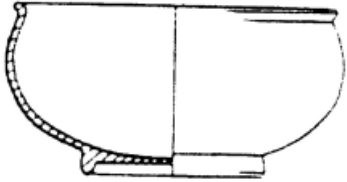
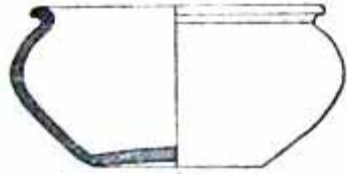

<p>Catalogue No. : Cat. 992 Type : D Body : Stoneware Glaze : white Decoration : Size (cm) : Height: 8; Diameter of mouth: 13.0; Diameter of base: 7.8.. Unearthed From : Collected By : Liaoning Provincial Museum Date (AD) : Published by : Shanghai renmin meishu chubanshe 1986, pl. 82; Liaoningsheng bowuguan 1961, pl. 103.</p>	 <p>Cat. 992</p>
<p>Catalogue No. : Cat. 993 Type : D Body : Stoneware Glaze : white Decoration : Size (cm) : Height: 10.4; Diameter of mouth: 15.8; Diameter of base: 8.1. Unearthed From : Collected By : Aohan Banner Museum, Inner Mongolia Date (AD) : late Published by : Shao Guotian 2004, pl. 145-1.</p>	 <p>Cat. 993</p>
<p>Catalogue No. : Cat. 994 Type : D Body : Stoneware Glaze : white Decoration : Size (cm) : Height: 12.3; Diameter of mouth: 17. Unearthed From : Collected By : Date (AD) : late Published by : Lu Jing 2003, pl. 3-520.</p>	 <p>Cat. 994</p>
<p>Catalogue No. : Cat. 995 Type : D Body : Pinkishearthenware Glaze : yellow Decoration : Size (cm) : Height: 10.9; Diameter of mouth: 16.3; Diameter of base: 8.3. Unearthed From : Collected By : The Palace Museu, Beijing Date (AD) : late Published by : Zhongguo taoci quanji bianji weiyuanhui 1999, pl. 61.</p>	 <p>Cat. 995</p>

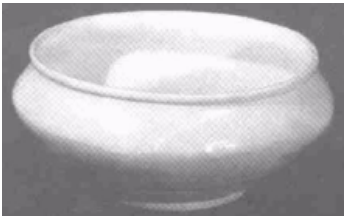

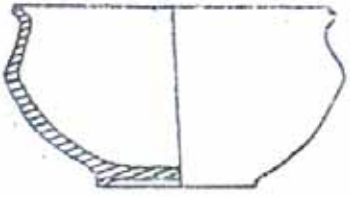

<p>Catalogue No. : Cat. 996 Type : D Body : Pinkishearthenware Glaze : green Decoration : Size (cm) : Height: 11.9; Diameter of mouth: 20.3. Unearthed From : Collected By : Date (AD) : late Published by : Lu Jing 2003, pl. 3-521.</p>	 <p>Cat. 996</p>
<p>Catalogue No. : Cat. 997 Type : D Body : Stoneware Glaze : white Decoration : Black dotted. Size (cm) : Height: 7.2; Diameter of mouth: 10.5; Diameter of base: 5.7. Unearthed From : Collected By : Liaoning Provincial Museum Date (AD) : late Published by : Shanghai renmin meishu chubanshe 1986, pl. 8; Liaoningsheng bowuguan 1961, pl.102.</p>	 <p>Cat. 997</p>
<p>Catalogue No. : Cat. 998 Type : D Body : Pinkish earthenware Glaze : green Decoration : Size (cm) : Height: 10.2; Diameter of mouth: 17.2. Unearthed From : Collected By : Chifeng Municipal Museum, Inner Mongolia Date (AD) : late Published by : Shanghai renmin meishu chubanshe 1986, pl. 154.</p>	 <p>Cat. 998</p>
<p>Catalogue No. : Cat. 999 Type : E Body : Stoneware Glaze : green Decoration : Size (cm) : Height: 11.8; Diameter of mouth: 20.8; Diameter of base: 11.7. Unearthed From : DQTL3 Collected By : Date (AD) : early Published by : Meng Jianren & Piao Chunyue 1997, 651-67, fig.6:4.</p>	 <p>Cat. 999</p>

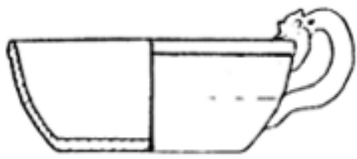

<p>Catalogue No. : Cat. 1000 Type : E Body : Stoneware Glaze : white Decoration : Size (cm) : Height: 11.2; Diameter of mouth: 21.2; Diameter of base: 12. Unearthed From : YLYZ Collected By : Date (AD) : 942 Published by : Neimenggu wenwu kaogu yanjiusuo 1996, 4-32, fig.48:3.</p>	 <p>Cat. 1000</p>
<p>Catalogue No. : Cat. 1001 Type : E Body : Stoneware Glaze : brown Decoration : Size (cm) : Height: 10.4; Diameter of mouth: 19.1; Diameter of base: 11.3. Unearthed From : YMT7 Collected By : Date (AD) : middle I Published by : Fwng Yongqian 1975, 40-8, fig.5:3.</p>	 <p>Cat. 1001</p>
<p>Catalogue No. : Cat. 1002 Type : E Body : Stoneware Glaze : brown Decoration : Size (cm) : Height: 10; Diameter of mouth: 19. Unearthed From : YMT7 Collected By : Liaoning Provincial Museum Date (AD) : middle I Published by : Shanghai renmin meishu chubanshe 1986, pl. 35.</p>	 <p>Cat. 1002</p>
<p>Catalogue No. : Cat. 1003 Type : E Body : Stoneware Glaze : white Decoration : Size (cm) : Height: 10; Diameter of mouth: 18.2; Diameter of base: 10.2. Unearthed From : LBB Collected By : Date (AD) : middle II Published by : Lin Maoyu & Xian Junyan 2001, 36-43.</p>	 <p>Cat. 1003</p>

<p>Catalogue No. : Cat. 1004 Type : Body : Stoneware Glaze : green Decoration : Size (cm) : Height: 11; Diameter of mouth: 20 . Unearthed From : KL3 Collected By : Date (AD) : middle II Published by : Wang Jianqun & Chen Xiangwei 1989, 51, fig.37:2.</p>	 <p>Cat. 1004</p>
---	---

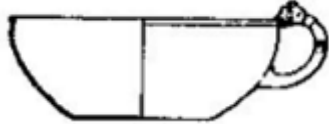
3.16 DRAGON-HANDLED BOWL





<p>Catalogue No. : Cat. 1005 Type : Body : Pinkish earthenware Glaze : yellow Decoration : Size (cm) : Height: 5.8; Diameter of mouth: 14.7; Diameter of base: 9.8. Unearthed From : ZWZ Collected By : Date (AD) : 1093 Published by: Zheng Shaozong 1996, 14-46, fig.21:6.</p>	 <p>Cat. 1005</p>
<p>Catalogue No. : Cat. 1006 Type : Body : Pinkish earthenware Glaze : yellow Decoration : Size (cm) : Height: 5.5; Diameter of mouth: 13.3. Unearthed From : ZSQ Collected By : Date (AD) : 1116 Published by: Hebeisheng wenwu guanlichu et al. 1975, 31-39, fig.7.</p>	 <p>Cat. 1006</p>
<p>Catalogue No. : Cat. 1007 Type : Body : Pinkish earthenware Glaze : yellow Decoration : Size (cm) : Height: 5.5; Diameter of mouth: 13.3. Unearthed From : ZSB Collected By : Date (AD) : 1089-1144 Published by: Tao Zongyi et al. 1990, 1-19, fig.27:9.</p>	 <p>Cat. 1007</p>

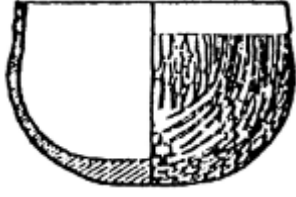

<p>Catalogue No. : Cat. 1008 Type : Body : Pinkish earthenware Glaze : yellow Decoration : Size (cm) : Diameter of mouth: 14.9. Unearthed From : JSFJ Collected By : Date (AD) : late Published by: Beijingshi wenwu guanlichu 1972, 35-40.</p>	 <p>Cat. 1008</p>
<p>Catalogue No. : Cat. 1009 Type : Body : Pinkish earthenware Glaze : green Decoration : Size (cm) : Height: 4.9; Diameter of mouth: 12.3. Unearthed From : Collected By : Private collection Date (AD) : Published by: Lu Jing 2003, pl. 3-529.</p>	 <p>Cat. 1009</p>
<p>Catalogue No. : Cat. 1010 Type : Body : grass Glaze : Decoration : Size (cm) : ? Unearthed From : XTM(MWG3) Collected By : Date (AD) : 1070 Published by: Ji Ping & Ta La 1997, 609-30, fig.13:3.</p>	 <p>Cat. 1010</p>
<p>Catalogue No. : Cat. 1011 Type : Body : silver Glaze : Decoration : Size (cm) : Height: 3.3; Diameter of mouth: 8; Diameter of base: 4.5. Unearthed From : Collected By : Aohan Banner Museum, Inner Mongolia Date (AD) : Yuan Dynasty Published by: Shao Guotian ed. 2004, pl. 203; Zhang Jingming 2005, pl. 160.</p>	 <p>Cat. 1011</p>

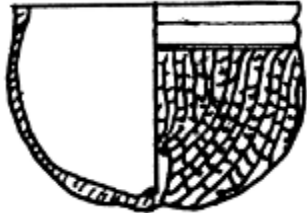
<p>Catalogue No. : Cat. 1012 Type : Body : silver Glaze : Decoration : Size (cm) : Height: 2.9; Diameter of mouth: 7.7; Diameter of base: 5.2. Unearthed From : Collected By : Aohan Banner Museum, Inner Mongolia Date (AD) : Yuan Dynasty Published by: Shao Guotian ed. 2004, pl. 203; Zhang Jingming 2005, pl. 166.</p>	 <p>Cat. 1012</p>
<p>Catalogue No. : Cat. 1013 Type : Body : gold Glaze : Decoration : Size (cm) : Height: 5; Diameter of mouth: 12.5. Unearthed From : Collected By : Inner Mongolia automomous region museum Date (AD) : Yuan Dynasty Published by: Zhang Jingming 2005, pl.159.</p>	 <p>Cat. 1013</p>

3.17 FLAT-BASE BOWL

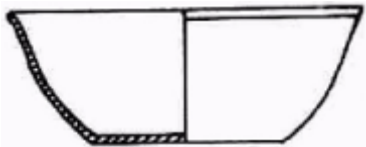

<p>Catalogue No. : Cat. 1014 Type : A Body : Silver Glaze : Decoration : Cane basket design Size (cm) : Height: 5.6; Diameter of mouth: 10.4; Diameter of base: 10.4. Unearthed From : Collected By : Inner Mongolia autonomous region museum Date (AD) : late Published by : Zhang Jingming 2005, pl. 134.</p>	 <p>Cat. 1014</p>
<p>Catalogue No. : Cat. 1015 Type : A Body : Porcelain Glaze : white Decoration : Cane basket design Size (cm) : Height: 5.5. Unearthed From : HYM Collected By : Date (AD) : 997 Published by : Huang Xiuchun et al. 1984, 361-81, fig.6:8.</p>	 <p>Cat. 1015</p>

<p>Catalogue No. : Cat. 1016 Type : A Body : Porcelain Glaze : white Decoration : Cane basket design Size (cm) : Height: 6.7. Unearthed From : WdGM Collected By : Date (AD) : middle Published by : Zhang Hanying 1996, 18-25, fig.1:3.</p>	 <p>Cat. 1016</p>
<p>Catalogue No. : Cat. 1017 Type : A Body : Porcelain Glaze : white Decoration : Cane basket design Size (cm) : Height: 9.7; Diameter of mouth: 19.2; Diameter of base: 4.3. Unearthed From : WdGM Collected By : Date (AD) : middle Published by : Lu Jing 2003, pl. 3-522.</p>	 <p>Cat. 1017</p>
<p>Catalogue No. : Cat. 1018 Type : A Body : Stoneware Glaze : green Decoration : Malbel ware Size (cm) : Height: 6.2; Diameter of mouth: 12.8. Unearthed From : PJG1 Collected By : Date (AD) : middle Published by : Ji Ping 1997, 639-50; Shao Guotian 2004, pl. 143.</p>	 <p>Cat. 1018</p>
<p>Catalogue No. : Cat. 1019 Type : B Body : Pinkish earthenware Glaze : yellow Decoration : Size (cm) : ? Unearthed From : ZSQ Collected By : Date (AD) : 1116 Published by : Hebeisheng wenwu guanlichu et al. 1975, 31-39, fig.8.</p>	 <p>Cat. 1019</p>

<p>Catalogue No. : Cat. 1020 Type : B Body : Porcelain Glaze : white Decoration : Size (cm) : Height: 5.2; Diameter of mouth: 13.6; Diameter of base: 7.2. Unearthed From : Tomb at Xiyongfeng village, Anci Township, Langfang City, Hebei Province Collected By : Relics office of Langfang, Hebei Date (AD) : late Published by : Langfang shi wenwu guanlisuo et al. 2001, 38-44, fig.8:6.</p>	 <p>Cat. 1020</p>
<p>Catalogue No. : Cat. 1021 Type : B Body : Pinkish earthenware Glaze : green Decoration : Size (cm) : Height: 8.5; Diameter of mouth: 21.5. Unearthed From : Collected By : Date (AD) : late Published by : Lu Jing 2003, pl. 3-526.</p>	 <p>Cat. 1021</p>
<p>Catalogue No. : Cat. 1022 Type : B Body : Gilt silver Glaze : Decoration : Floral designs Size (cm) : Height: 6.1; Diameter of mouth: 16.8. Unearthed From : Collected By : Research Institute of Cultural Relics and Archaeology of Inner Mongolia Date (AD) : middle Published by : Zhang Jingming 2005, pl. 128.</p>	 <p>Cat. 1022</p>

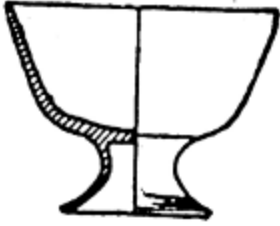
3.18 STEP-FOOT BOWL

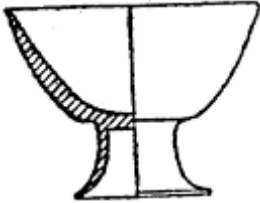

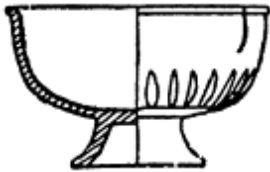
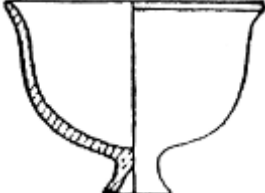
<p>Catalogue No. : Cat. 1023 Type : Body : stoneware Glaze : white Decoration : Size (cm) : Height: 7.4. Unearthed From : SZG1 Collected By : Date (AD) : early Published by : Shao Guotian 1987, 889-904.</p>	 <p>Cat. 1023</p>
---	---

<p>Catalogue No. : Cat. 1024 Type : Body : stoneware Glaze : white Decoration : Size (cm) : Height: 7.2. Unearthed From : HLB1 Collected By : Date (AD) : early Published by : Li Yufeng 1991, 106-19, 23, fig.3:8.</p>	 <p>Cat. 1024</p>
<p>Catalogue No. : Cat. 1025 Type : Body : stoneware Glaze : white Decoration : Size (cm) : Height: 6.6. Unearthed From : Collected By : Date (AD) : Published by : Sugimura Yuzo 1074, pl. 53.</p>	 <p>Cat. 1025</p>
<p>Catalogue No. : Cat. 1026 Type : Body : Pinkish earthenware Glaze : green Decoration : Size (cm) : Height: 5.5; Diameter of mouth: 9. Unearthed From : QCH Collected By : Liaoning Provincial Museum Date (AD) : Middle Published by : Jin Fengyi 1980, 17-29, fig.12.</p>	 <p>Cat. 1026</p>
<p>Catalogue No. : Cat. 1027 Type : Body : Stoneware Glaze : white Decoration : Size (cm) : Height: 6; Diameter of mouth: 8.5. Unearthed From : At Liao old city of Lizhou, Kaozuo county, Liaoning Province Collected By : Date (AD) : Published by : Lu Jing 2003, pl. 3-629.</p>	 <p>Cat. 1027</p>

<p>Catalogue No. : Cat. 1028 Type : Body : Pinkish earthenware Glaze : green Decoration : Size (cm) : Height: 7.5; Diameter of mouth: 10.2; Diameter of base: 4.2. Unearthed From : Collected By : Liaoning Provincial Museum Date (AD) : late Published by : Liaoning sheng bowuguan 1961, pl. 93.</p>	 <p>Cat. 1028</p>
---	---

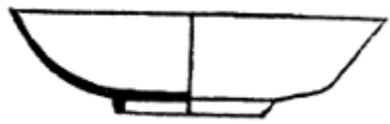
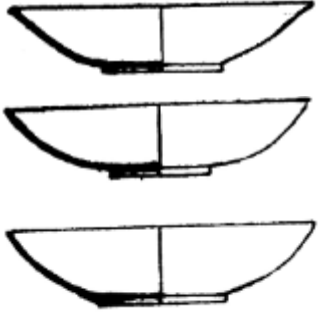
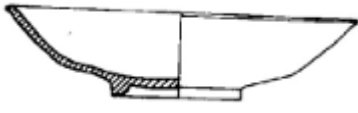
3.19 RING-FOOT DISH

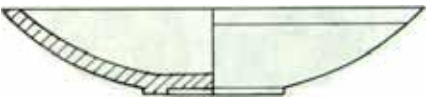
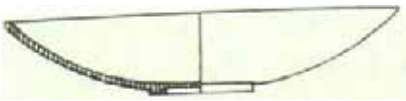
<p>Catalogue No. : Cat. 1029 Type : Aa Body : Porcelain Glaze : white Decoration : Size (cm) : Height: 4; Diameter of mouth: 14.9. Unearthed From : GZX Collected By : Date (AD) : 1026 Published by : Zhu Zifang & Xu Ji 1983, 168-95, fig.4:6.</p>	 <p>Cat. 1029</p>
<p>Catalogue No. : Cat. 1030 Type : Aa Body : Porcelain Glaze : white Decoration : Size (cm) : Height: 3-3.5; Diameter of mouth: 13-14. Unearthed From : SJG1 Collected By : Date (AD) : 1002 Published by : Deng Baoxue et al. 1983, 30-38, fig.13:1-3.</p>	 <p>Cat. 1030</p>
<p>Catalogue No. : Cat. 1031 Type : Aa Body : Porcelain Glaze : white Decoration : Size (cm) : Height: 4.8; Diameter of mouth: 20.6; Diameter of base: 7.3. Unearthed From : GMZ Collected By : Date (AD) : late Published by : Li Dajun 1997, 30-6, fig.7:5.</p>	 <p>Cat. 1031</p>

<p>Catalogue No. : Cat. 1032 Type : Aa Body : Pinkish earthenware Glaze : white Decoration : Size (cm) : Height: 4.2; Diameter of mouth: 16.8; Diameter of base: 6.6. Unearthed From : DPC Collected By : Date (AD) : middle Published by : Liu Junyu & Sun Gang 1999, 31-4, fig.3.</p>	 <p>Cat. 1032</p>
<p>Catalogue No. : Cat. 1033 Type : Aa Body : Stoneware Glaze : white Decoration : Size (cm) : Height: 3.4; Diameter of mouth: 16. Unearthed From : GSZ1 (M1:1) Collected By : Date (AD) : late Published by : Yang Dongxin 2001, 87-88, fig.2:4.</p>	 <p>Cat. 1033</p>
<p>Catalogue No. : Cat. 1034 Type : Aa Body : Stoneware Glaze : white Decoration : Size (cm) : Height: 5.5; Diameter of mouth: 21; Diameter of base: 7.4. Unearthed From : GSZ2 (M2:3) Collected By : Date (AD) : late Published by : Yang Dongxin 2001, 87-88, fig.4:4.</p>	 <p>Cat. 1034</p>
<p>Catalogue No. : Cat. 1035 Type : Aa Body : Pinkish earthenware Glaze : Three-colored Decoration : Moulded floral designs Size (cm) : Height: 3.6-5; Diameter of mouth: 17.5-21. Unearthed From : XLZZ4 Collected By : Date (AD) : late Published by : Li Yiyou 1961, 44-49, fig.4:3.</p>	 <p>Cat. 1035</p>

Catalogue No. : Cat. 1036
 Type : Aa
 Body : Pinkish earthenware
 Glaze : Three-colored
 Decoration : Moulded floral designs
 Size (cm) : Height: 3.6-5; Diameter of mouth: 17.5-21.
 Unearthed From : XLZZ3
 Collected By :
 Date (AD) : late
 Published by : Li Yiyou 1961, 44-49, fig.4:2.



Cat. 1036

Catalogue No. : Cat. 1037
 Type : Aa
 Body : Pinkish earthenware
 Glaze : Three-colored
 Decoration : Moulded floral designs
 Size (cm) : Height: 3.6-5; Diameter of mouth: 17.5-21.
 Unearthed From : XLZZ1
 Collected By :
 Date (AD) : late
 Published by : Li Yiyou 1961, 44-49, fig.4:1;
 Neimenggu zizhiqiu wenhuating & Zhongguo lishi bowuguan 2002, pl. 296.





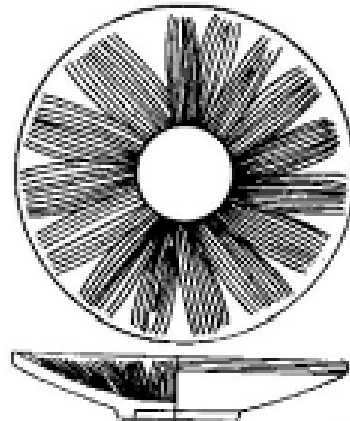

Cat. 1037

Catalogue No. : Cat. 1038
 Type : Aa
 Body : Stoneware
 Glaze : white
 Decoration : Incised spray lines inside the dish.
 Size (cm) : ?
 Unearthed From : LQW kiln site
 Collected By :
 Date (AD) : late
 Published by : Beijingshi wenwu yanjiusuo 2002, 282, fig.96:1.

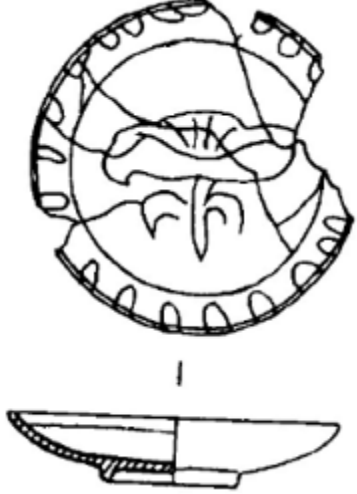

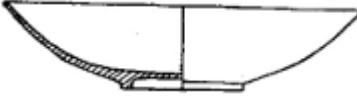
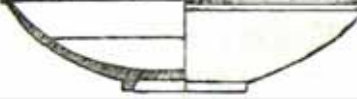
Cat. 1038

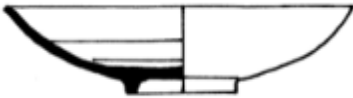
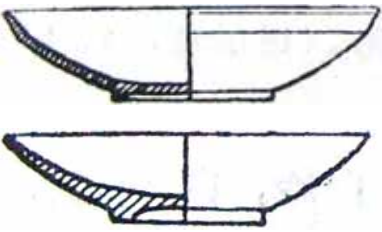
<p>Catalogue No. : Cat. 1039 Type : Aa Body : Pinkish earthenware Glaze : Three-colored Decoration : Painted lotus leaf designs inside the dish Size (cm) : Height: 4.5; Diameter of mouth: 20. Unearthed From : A tomb at Xinlin village, Xianfeng Township, Aluke'erqin Banner, Inner Mongolia Collected By : Date (AD) : late Published by : Aluke'erqin qi wenguansuo et al. 1996, 78-81, fig.2:2.</p>	 <p>Cat. 1039</p>
<p>Catalogue No. : Cat. 1040 Type : Aa Body : Pinkish earthenware Glaze : white Decoration : Size (cm) : Height: 4.3 Diameter of mouth: 18.4; Diameter of base: 6.4. Unearthed From : WLHD Collected By : Date (AD) : late Published by : Wang Jianguo & Ma Junshan 1986, 74-76, fig.3:1.</p>	 <p>Cat. 1040</p>
<p>Catalogue No. : Cat. 1041 Type : Aa Body : Stoneware Glaze : white Decoration : Size (cm) : Height: 5.5 Diameter of mouth: 21; Diameter of base: 6.8. Unearthed From : YS3 Collected By : Date (AD) : late Published by : Shao Guotian et al. 1999, 1-38, 43, fig.16:4</p>	 <p>Cat. 1041</p>
<p>Catalogue No. : Cat. 1042 Type : Aa Body : Porcelain Glaze : white Decoration : Size (cm) : Height: 4.8 Diameter of mouth: 20. Unearthed From : YMT8 Collected By : Date (AD) : late Published by : He Xianwu & Zhang Xingde 1996, 41-47, fig.4:2.</p>	 <p>Cat. 1042</p>





<p>Catalogue No. : Cat. 1043 Type : Aa Body : Stoneware Glaze : white Decoration : Size (cm) : Height: 4.8 Diameter of mouth: 18. Unearthed From : PJG3 Collected By : Date (AD) : late Published by : Ji Ping 1997, 639-50, fig.7:3.</p>	 <p>Cat. 1043</p>
<p>Catalogue No. : Cat. 1044 Type : Aa Body : Stoneware Glaze : white Decoration : Size (cm) : Height: 3.7-5.5 Diameter of mouth: 16-25.5. Unearthed From : HQY6 Collected By : Date (AD) : late Published by : Lu Sixian & Du Chengwu 1983, 1-8, fig.18; Wumeng wenwu gongzuozhan 1985, 7-44, fig.1,2.</p>	 <p>Cat. 1044</p>
<p>Catalogue No. : Cat. 1045 Type : Aa Body : Pinkish earthenware Glaze : yellow Decoration : Size (cm) : Height: 5.5; Diameter of mouth: 20. Unearthed From : Collected By : Indianapolis Museum of Art Date (AD) : late Published by : Mino Yutaka et al. 1973, pl. 21.</p>	 <p>Cat. 1045</p>
<p>Catalogue No. : Cat. 1046 Type : Aa Body : Pinkish earthenware Glaze : yellow Decoration : Impressed floral designs Size (cm) : Height: 6.5; Diameter of mouth: 20.5; Diameter of base: 7.4. Unearthed From : Collected By : Guan Baocong collection Date (AD) : late Published by : Lu Jing 2003, pl. 3-535.</p>	 <p>Cat. 1046</p>



<p>Catalogue No. : Cat. 1047 Type : Aa Body : Pinkish earthenware Glaze : yellow Decoration : Impressed floral designs Size (cm) : Height: 3.5; Diameter of mouth: 17; Diameter of base: 6. Unearthed From : Collected By : The Palace Museum, Beijing Date (AD) : late Published by : Zhongguo taoci quanji bianji weiyuanhui 1999, pl. 62.</p>	 <p>Cat. 1047</p>
<p>Catalogue No. : Cat. 1048 Type : Aa Body : Pinkish earthenware Glaze : yellow Decoration : Size (cm) : Diameter of mouth: 19.3. Unearthed From : Collected By : Date (AD) : late Published by : Sugimura Yuzo 1974, pl. 52.</p>	 <p>Cat. 1048</p>
<p>Catalogue No. : Cat. 1049 Type : Aa Body : Pinkish earthenware Glaze : yellow Decoration : Size (cm) : Height: 4.9; Diameter of mouth: 19.9; Diameter of base: 6.9. Unearthed From : Collected By : Guan Baocong collection Date (AD) : late Published by : Lu Jing 2003, pl. 3-536.</p>	 <p>Cat. 1049</p>
<p>Catalogue No. : Cat. 1050 Type : Aa Body : Pinkish earthenware Glaze : Three-colored Decoration : Moulded floral designs Size (cm) : Height: 5; Diameter of mouth: 21; Diameter of base: 6. Unearthed From : Collected By : Inner Mongolia autonomous region museum Date (AD) : late Published by : Neimenggu zizhiqu wenhuating & Zhongguo lishi bowuguan 2002, pl. 295.</p>	 <p>Cat. 1050</p>



<p>Catalogue No. : Cat. 1051 Type : Aa Body : Pinkish earthenware Glaze : Three-colored Decoration : Moulded floral designs Size (cm) : Diameter of mouth: 25.2. Unearthed From : Collected By : Tokyo National Museum Date (AD) : late Published by : Sugimura Yuzo 1974, pl. 72.</p>	 <p>Cat. 1051</p>
<p>Catalogue No. : Cat. 1052 Type : Aa Body : Pinkish earthenware Glaze : Three-colored Decoration : Moulded floral designs Size (cm) : Diameter of mouth: 25. Unearthed From : Collected By : Date (AD) : late Published by : Sugimura Yuzo 1974, pl. 70.</p>	 <p>Cat. 1052</p>
<p>Catalogue No. : Cat. 1053 Type : Aa Body : Pinkish earthenware Glaze : Three-colored Decoration : Moulded floral designs Size (cm) : Diameter of mouth: 17.4. Unearthed From : Collected By : Date (AD) : late Published by : Sugimura Yuzo 1974, pl. 18.</p>	 <p>Cat. 1053</p>
<p>Catalogue No. : Cat. 1054 Type : Aa Body : Pinkish earthenware Glaze : Three-colored Decoration : Moulded floral designs Size (cm) : Height: 5; Diameter of mouth: 24. Unearthed From : A tomb at Shuangsheng Village, Longchang Township, Balin Left Banner, Inner Mongolia Collected By : Liaoshangjing Museum, Inner Mongolia Date (AD) : late Published by : Tang Cailan 2005, pl. 79.</p>	 <p>Cat. 1054</p>

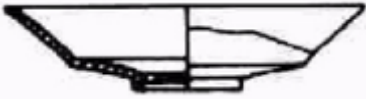

<p>Catalogue No. : Cat. 1055 Type : Aa Body : Pinkish earthenware Glaze : Three-colored Decoration : Moulded floral designs Size (cm) : Diameter of mouth: 24.6. Unearthed From : Collected By : Date (AD) : late Published by : Sugimura Yuzo 1974, pl. 71.</p>	 <p>Cat. 1055</p>
<p>Catalogue No. : Cat. 1056 Type : Aa Body : Pinkish earthenware Glaze : Three-colored Decoration : Moulded floral designs Size (cm) : Height: 5.1; Diameter of mouth: 23; Diameter of base: 7.5. Unearthed From : Collected By : Guan Baocong collection Date (AD) : late Published by : Lu Jing 2003, pl. 4-188.</p>	 <p>Cat. 1056</p>
<p>Catalogue No. : Cat. 1057 Type : Aa Body : Pinkish earthenware Glaze : Three-colored Decoration : Moulded floral designs Size (cm) : Height: 5.2; Diameter of mouth: 22; Diameter of base: 8. Unearthed From : Collected By : Guan Baocong collection Date (AD) : late Published by : Lu Jing 2003, pl. 4-189.</p>	 <p>Cat. 1057</p>
<p>Catalogue No. : Cat. 1058 Type : Aa Body : Pinkish earthenware Glaze : Three-colored Decoration : Moulded floral designs Size (cm) : Height: 4.0; Diameter of mouth: 16.7. Unearthed From : Collected By : Liaoning Tieling qunzhongyishuguan wenwuzu Date (AD) : late Published by : Shanghai renmin meishu chubanshe 1986, pl. 110; Liaoningsheng bowuguan 1961, pl. 78.</p>	 <p>Cat. 1058</p>

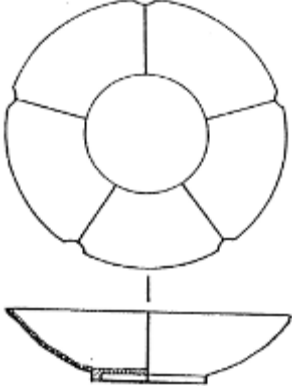
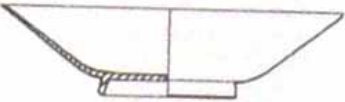

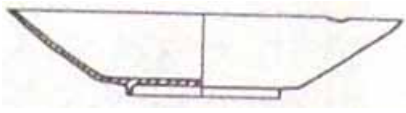
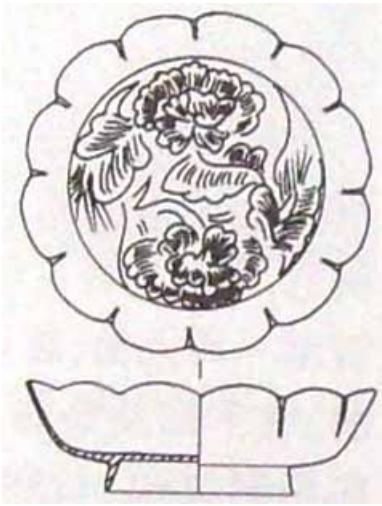
<p>Catalogue No. : Cat. 1059 Type : Aa Body : Pinkish earthenware Glaze : Three-colored Decoration : Moulded floral designs Size (cm) : Height: 4.2; Diameter of mouth: 16.9. Unearthed From : Collected By : Liaoning Provincial Museum Date (AD) : late Published by : Shanghai renmin meishu chubanshe 1986, pl. 117; Liaoningsheng bowuguan 1961, pl. 76.</p>	 <p>Cat. 1059</p>
<p>Catalogue No. : Cat. 1060 Type : Aa Body : Pinkish earthenware Glaze : yellow Decoration : Impressed floral designs Size (cm) : Height: 3.3; Diameter of mouth: 12.7. Unearthed From : Collected By : Liaoning Tieling qunzhongyishuguan wenwuzu Date (AD) : late Published by : Shanghai renmin meishu chubanshe 1986, pl. 99.</p>	 <p>Cat. 1060</p>
<p>Catalogue No. : Cat. 1061 Type : Aa Body : Pinkish earthenware Glaze : white Decoration : Impressed floral designs Size (cm) : Height: 4.2; Diameter of mouth: 16.9. Unearthed From : Collected By : Liaoning Tieling qunzhongyishuguan wenwuzu Date (AD) : late Published by : Shanghai renmin meishu chubanshe 1986, pl. 102.</p>	 <p>Cat. 1061</p>
<p>Catalogue No. : Cat. 1062 Type : Aa Body : Pinkish earthenware Glaze : Three-colored Decoration : Incised floral designs Size (cm) : Height: 3; Diameter of mouth: 16. Unearthed From : At Dongzhan commune of Qianguo county, Jilin Province Collected By : Jilin Provincial Museum Date (AD) : late Published by : Shanghai renmin meishu chubanshe 1986, pl. 120.</p>	 <p>Cat. 1062</p>

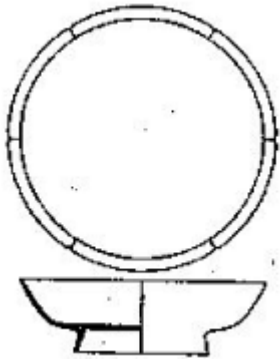

<p>Catalogue No. : Cat. 1063 Type : Aa Body : Pinkish earthenware Glaze : green Decoration : Size (cm) : Height: 5; Diameter of mouth: 20.1. Unearthed From : Collected By : Chifeng Municipal Museum Date (AD) : late Published by : Shanghai renmin meishu chubanshe 1986, pl. 139.</p>	 <p>Cat. 1063</p>
<p>Catalogue No. : Cat. 1064 Type : Aa Body : Pinkish earthenware Glaze : Three-colored Decoration : Moulded floral designs Size (cm) : Height: 6.4; Diameter of mouth: 24.3. Unearthed From : Collected By : Jilin Provincial Museum Date (AD) : late Published by : Shanghai renmin meishu chubanshe 1986, pl. 162.</p>	 <p>Cat. 1064</p>
<p>Catalogue No. : Cat. 1065 Type : Aa Body : Pinkish earthenware Glaze : Three-colored Decoration : Moulded floral designs Size (cm) : Height: 6.2; Diameter of mouth: 25; Diameter of base: 8.1. Unearthed From : Collected By : Liaoning Provincial Museum Date (AD) : late Published by : Liaoningsheng bowuguan 1961, pl. 75.</p>	 <p>Cat. 1065</p>
<p>Catalogue No. : Cat. 1066 Type : Aa Body : Pinkish earthenware Glaze : Three-colored Decoration : Moulded peony and butterfly designs Size (cm) : Height: 3.9; Diameter of mouth: 16.9; Diameter of base: 6.5. Unearthed From : Collected By : Liaoning Provincial Museum Date (AD) : late Published by : Liaoningsheng bowuguan 1961, pl. 77.</p>	 <p>Cat. 1066</p>

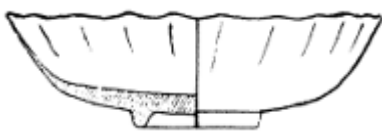

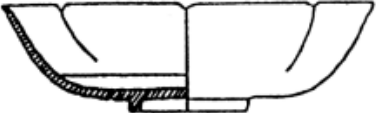
<p>Catalogue No. : Cat. 1067 Type : Aa Body : Porcelain Glaze : white Decoration : Size (cm) : Height: 5.6; Diameter of mouth: 21.6; Diameter of base: 6.8. Unearthed From : Tomb at Xiyongfeng village, Anci Township, Langfang city, Hebei province Collected By : Relics office of Langfang, Hebei Province Date (AD) : late Published by : Langfang shi wenwu guanlisuo et al. 2001, 38-44, fig.8:5.</p>	 <p>Cat. 1067</p>
<p>Catalogue No. : Cat. 1068 Type : Aa Body : Pinkish earthenware Glaze : Three-colored Decoration : Moulded floral designs Size (cm) : Height: 8.4; Diameter of mouth: 30.1; Diameter of base: 9.6. Unearthed From : Collected By : Liaoning Provincial Museum Date (AD) : late Published by : Zhongguo taoci quanji bianji weiyuanhui 1999, pl. 98.</p>	 <p>Cat. 1068</p>
<p>Catalogue No. : Cat. 1069 Type : Ab Body : Porcelain Glaze : white Decoration : Five lobed mouth Size (cm) : Height: 4.8; Diameter of mouth: 9; Diameter of base: 7.6. Unearthed From : DQTL3 Collected By : Date (AD) : early Published by : Meng Jianren & Piao Chunyue 1997, 651-67, fig.10:6.</p>	 <p>Cat. 1069</p>
<p>Catalogue No. : Cat. 1070 Type : Ab Body : Porcelain Glaze : white Decoration : Five lobed mouth Size (cm) : Height: 6.6; Diameter of mouth: 25; Diameter of base: 12. Unearthed From : Tomb of Xiaohe at Fuxin, Liaoning Province (M4: 26) Collected By : Date (AD) : middle II Published by : Wan Xiongfei 2005, 33-44, fig.10:6.</p>	 <p>Cat. 1070</p>

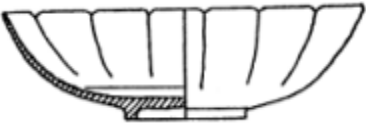
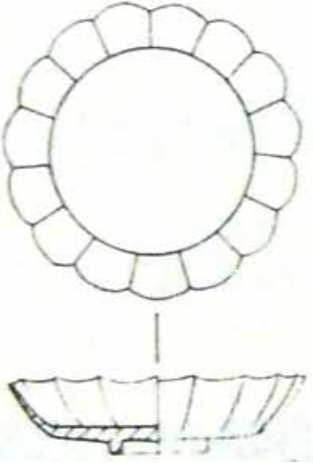

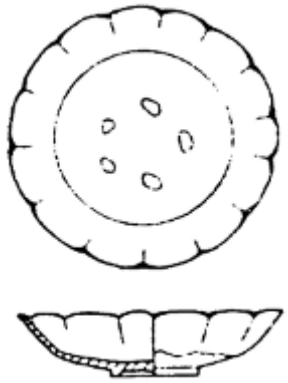
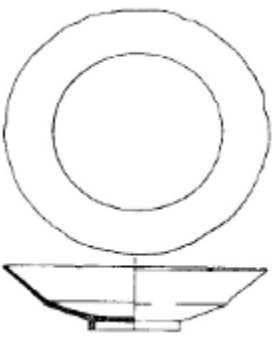
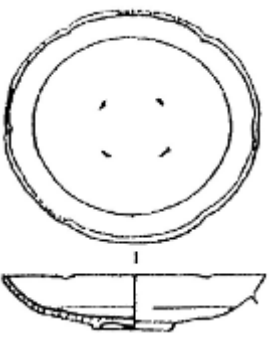

<p>Catalogue No. : Cat. 1071 Type : Ab Body : Porcelain Glaze : white Decoration : Five lobed mouth Size (cm) : Height: 5.4; Diameter of mouth: 25; Diameter of base: 9.4. Unearthed From : Tomb of Xiaohe at Fuxin, Liaoning Province (M4: 27) Collected By : Date (AD) : middle II Published by : Wan Xiongfei 2005, 33-44, fig.10:7.</p>	 <p>Cat. 1071</p>
<p>Catalogue No. : Cat. 1072 Type : Ab Body : Porcelain Glaze : white Decoration : Twelve lobed mouth Size (cm) : Height: 6.8; Diameter of mouth: 21.6; Diameter of base: 11.6. Unearthed From : Tomb of Xiaohe at Fuxin, Liaoning Province (M4: 32) Collected By : Date (AD) : middle II Published by : Wan Xiongfei 2005, 33-44, fig.10:8.</p>	 <p>Cat. 1072</p>
<p>Catalogue No. : Cat. 1073 Type : Ab Body : Porcelain Glaze : white Decoration : Twelve lobed mouth Size (cm) : Height: 5; Diameter of mouth: 16.8; Diameter of base: 8.8. Unearthed From : Tomb of Xiaohe at Fuxin, Liaoning Province (M4: 36) Collected By : Date (AD) : middle II Published by : Wan Xiongfei 2005, 33-44, fig.10:9.</p>	 <p>Cat. 1073</p>

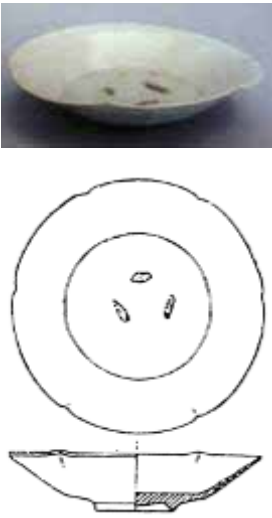

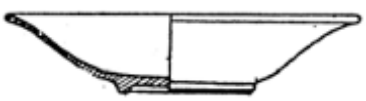
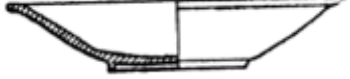
<p>Catalogue No. : Cat. 1074 Type : Ab Body : Porcelain Glaze : white Decoration : Six lobed mouth Size (cm) : ? Unearthed From : Pagoda JGS Collected By : Date (AD) : 1013 Published by : Su Tianjun 1964, 49-53.</p>	 <p>Cat. 1074</p>
<p>Catalogue No. : Cat. 1075 Type : Ab Body : Porcelain Glaze : white Decoration : Eight lobed mouth Size (cm) : Height: 4.3; Diameter of mouth: 14.3; Diameter of base: 4.5. Unearthed From : DXG1 Collected By : Date (AD) : 997-1021 Published by : Xin Yan & Hua Yubing 1991, 40-47, fig.3:5.</p>	 <p>Cat. 1075</p>
<p>Catalogue No. : Cat. 1076 Type : Ab Body : Porcelain Glaze : white Decoration : Twelve lobed mouth Size (cm) : Height: 4.6; Diameter of mouth: 15.5. Unearthed From : DXG1 Collected By : Date (AD) : 997-1021 Published by : Xin Yan & Hua Yubing 1991, 40-47.</p>	 <p>Cat. 1076</p>
<p>Catalogue No. : Cat. 1077 Type : Ab Body : Porcelain Glaze : white Decoration : Four to twenty-one lobed mouth Size (cm) : Height: 2.6-3.6; Diameter of mouth: 10.6-11.7 Unearthed From : Pagoda QZBT Collected By : Date (AD) : 1049 Published by : De Xin et al. 1994, 4-33, fig.29:7.</p>	 <p>Cat. 1077</p>



<p>Catalogue No. : Cat. 1078 Type : Ab Body : Porcelain Glaze : white Decoration : Six lobed mouth Size (cm) : Height: 4.1; Diameter of mouth: 14.8; Diameter of base: 4.8. Unearthed From : DXG1 Collected By : Date (AD) : middle III Published by : Xin Yan & Hua Yubing 1991, 40-47, fig.3:3.</p>	 <p>Cat. 1078</p>
<p>Catalogue No. : Cat. 1079 Type : Ab Body : Porcelain Glaze : white Decoration : Six lobed mouth Size (cm) : Height: 4.6; Diameter of mouth: 15.5. Unearthed From : DXG1 Collected By : Date (AD) : middle III Published by : Xin Yan & Hua Yubing 1991, 40-47, fig.3:1.</p>	 <p>Cat. 1079</p>
<p>Catalogue No. : Cat. 1080 Type : Ab Body : Porcelain Glaze : white Decoration : Twelve lobed mouth Size (cm) : Height: 4.4; Diameter of mouth: 15; Diameter of base: 4.5. Unearthed From : DXG1 Collected By : Date (AD) : middle III Published by : Xin Yan & Hua Yubing 1991, 40-47, fig.3:2.</p>	 <p>Cat. 1080</p>
<p>Catalogue No. : Cat. 1081 Type : Ab Body : Porcelain Glaze : white Decoration : Sixteen lobed mouth Size (cm) : Height: 2.8; Diameter of mouth: 11; Diameter of base: 4. Unearthed From : ZWZ Collected By : Date (AD) : 1093 Published by : Zheng Shaozong 1996, 14-46, fig.32:6.</p>	 <p>Cat. 1081</p>

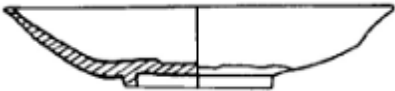
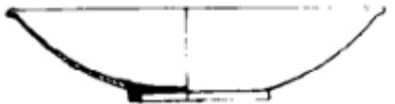
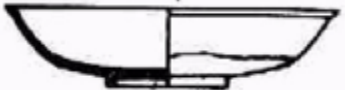

<p>Catalogue No. : Cat. 1082 Type : Ab Body : Porcelain Glaze : white Decoration : Twelve lobed mouth Size (cm) : Height: 3; Diameter of mouth: 11.7; Diameter of base: 4. Unearthed From : ZWZ Collected By : Date (AD) : 1093 Published by : Zheng Shaozong 1996, 14-46, fig.32:8.</p>	 <p>Cat. 1082</p>
<p>Catalogue No. : Cat. 1083 Type : Ab Body : Porcelain Glaze : White 青白 Decoration : Six lobed mouth Size (cm) : Height: 3.9; Diameter of mouth: 20; Diameter of base: 6.4. Unearthed From : Tomb at Nanjianta, Anci district, Langfang city, Hebei Province Collected By : Relics office of Langfang, Hebei Province Date (AD) : late Published by : Langfang shi wenwu guanlisuo 1996, 9-12,58.</p>	 <p>Cat. 1083</p>
<p>Catalogue No. : Cat. 1084 Type : Ab Body : Porcelain Glaze : white Decoration : Six lobed mouth Size (cm) : Height: 2.8-3.2; Diameter of mouth: 13-14; Diameter of base: 4. Unearthed From : PJG3 Collected By : Date (AD) : late Published by : Jiping 1997, 639-50, fig.7:7.</p>	 <p>Cat. 1084</p>
<p>Catalogue No. : Cat. 1085 Type : Ab Body : Porcelain Glaze : white Decoration : Twelve lobed mouth Size (cm) : Height: 3; Diameter of mouth: 11.2; Diameter of base: 4.1. Unearthed From : Collected By : Guan Baocong collection Date (AD) : late Published by : Lu Jing 2003, pl. 3-548.</p>	 <p>Cat. 1085</p>

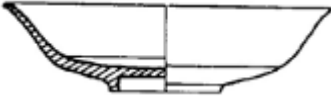

<p>Catalogue No. : Cat. 1086 Type : Ab Body : Porcelain Glaze : white Decoration : Six lobed mouth Size (cm) : Height: 2.7; Diameter of mouth: 13.6. Unearthed From : BTYZ Collected By : Liaoning Provincial Museum Date (AD) : late Published by : Shanghai renmin meishu chubanshe 1986, pl. 165; Feng Yongqian 1960 15-24, fig.9:2</p>	 <p>Cat. 1086</p>
<p>Catalogue No. : Cat. 1087 Type : Ab Body : Porcelain Glaze : white Decoration : Size (cm) : Height: 3; Diameter of mouth: 11.5. Unearthed From : Collected By : Guan Baocong collection Date (AD) : late Published by : Lu Jing 2003, pl. 3-551.</p>	 <p>Cat. 1087</p>
<p>Catalogue No. : Cat. 1088 Type : Ba Body : Porcelain Glaze : white Decoration : Size (cm) : Height: 4.4; Diameter of mouth: 21. Unearthed From : SZG1 Collected By : Date (AD) : early Published by : Shao Guotian 1987, 889-904.</p>	 <p>Cat. 1088</p>
<p>Catalogue No. : Cat. 1089 Type : Ba Body : Porcelain Glaze : white Decoration : Size (cm) : Height: 5; Diameter of mouth: 25.1. Unearthed From : BTZ Collected By : Date (AD) : 1081 Published by : Shao Guotian 1978, 119-121, fig.4:3</p>	 <p>Cat. 1089</p>

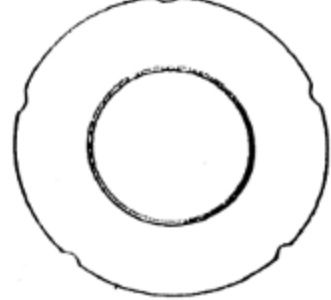
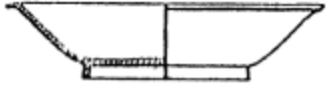
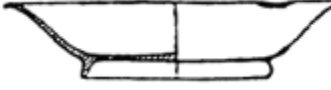
<p>Catalogue No. : Cat. 1090 Type : Ba Body : Porcelain Glaze : white Decoration : Size (cm) : Height: 2.5-3.6; Diameter of mouth: 16.5; Diameter of base: 6.5-7.2. Unearthed From : PJG3 Collected By : Date (AD) : Late Published by : Ji Ping 1997, 639-50, fig.7:2</p>	 <p>Cat. 1090</p>
<p>Catalogue No. : Cat. 1091 Type : Ba Body : Porcelain Glaze : white Decoration : Size (cm) : Height: 5.1; Diameter of mouth: 21.5. Unearthed From : Collected By : Guan Baocong collection Date (AD) : Published by : Lu Jing 2003, pl. 3-556.</p>	 <p>Cat. 1091</p>
<p>Catalogue No. : Cat. 1092 Type : Ba Body : Stoneware Glaze : white Decoration : Size (cm) : Height: 4.7; Diameter of mouth: 17.6; Diameter of base: 7.8. Unearthed From : A tomb at Chaouba, Chaoyang, Liaoning Collected By : Chapyang Municipal Museum, Liaoning Date (AD) : late Published by : Chaoyangshi bowuguan & Chaoyangshi longchengqu bowuguan 2004, 64-66.</p>	 <p>Cat. 1092</p>
<p>Catalogue No. : Cat. 1093 Type : Ba Body : Stoneware Glaze : white Decoration : Size (cm) : Height: 4.8; Diameter of mouth: 18.2; Diameter of base: 6.4. Unearthed From : A tomb at Chenggou, Fuxin, Liaoning Collected By : Fuxin Municipal Museum, Liaoning Date (AD) : late Published by : Hu Jian et al. 1998, 25-28.</p>	 <p>Cat. 1093</p>

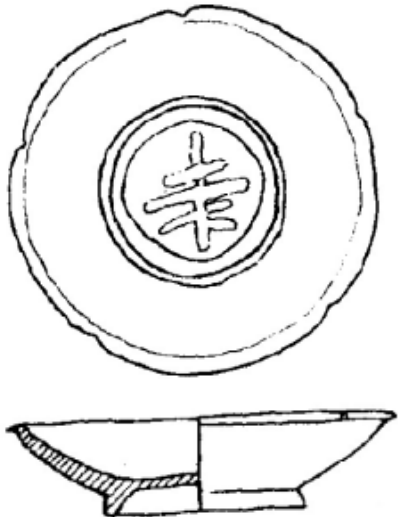
<p>Catalogue No. : Cat. 1094 Type : Ba Body : Stoneware Glaze : white Decoration : Size (cm) : Height: 2.6; Diameter of mouth: 13-13.5; Diameter of base: 5. Unearthed From : TJYZ Collected By : Chifeng Municipal Museum, Inner Mongolia Date (AD) : late Published by : Zhao Guodong et al. 1997, 68-72, fig.4:1</p>	 <p>Cat. 1094</p>
<p>Catalogue No. : Cat. 1095 Type : Ba Body : Stoneware Glaze : white Decoration : Size (cm) : Height: 5.8; Diameter of mouth: 15; Diameter of base: 5.8. Unearthed From : WFG Collected By : Date (AD) : late Published by : Sun Yutie 1998, 51-2, fig.3:5</p>	 <p>Cat. 1095</p>
<p>Catalogue No. : Cat. 1096 Type : Ba Body : Stoneware Glaze : white Decoration : Size (cm) : Height: 5.2; Diameter of mouth: 22.4; Diameter of base: 8. Unearthed From : Tomb at Xiyongfeng village, Anci district, Langfang city, Hebei Province Collected By : Date (AD) : late Published by : Langfang shi wenwu guanlisuo et al. 2001, 38-44, fig.8:2</p>	 <p>Cat. 1096</p>
<p>Catalogue No. : Cat. 1097 Type : Ba Body : Stoneware Glaze : white Decoration : impressed design Size (cm) : Height: 5.5; Diameter of mouth: 25.5. Unearthed From : HQY9 Collected By : Date (AD) : late Published by : Wumeng wenwu gongzuozhan & Neimenggu wenwu gongzuodui 45-71, fig.15</p>	 <p>Cat. 1097</p>



<p>Catalogue No. : Cat. 1098 Type : Ba Body : Stoneware Glaze : white Decoration : Size (cm) : Height: 6.5; Diameter of mouth: 18.3; Diameter of base: 6.5. Unearthed From : TJYZ Collected By : Date (AD) : late Published by : Zhao Guodong et al. 1997, 68-72, fig.4:7</p>	 <p>Cat. 1098</p>
<p>Catalogue No. : Cat. 1099 Type : Ba Body : Porcelain Glaze : white Decoration : Size (cm) : Height: 3.1; Diameter of mouth: 10.5; Diameter of base: 4.8. Unearthed From : WFG Collected By : Date (AD) : late Published by : Sun Yutie 1998, 51-2, fig.3:6</p>	 <p>Cat. 1099</p>
<p>Catalogue No. : Cat. 1100 Type : Bb Body : Porcelain Glaze : white Decoration : Size (cm) : Height: 3.3; Diameter of mouth: 15.6; Diameter of base: 8. Unearthed From : DQTL3 Collected By : Date (AD) : early Published by : Meng Jianren & Piao Chunyue 1997, 651-67, fig.10:4</p>	  <p>Cat. 1100</p>
<p>Catalogue No. : Cat. 1101 Type : Bb Body : Porcelain Glaze : white Decoration : Size (cm) : Height: 3.6; Diameter of mouth: 15.4; Diameter of base: 8. Unearthed From : HLB1 Collected By : Date (AD) : early Published by : Li Yufeng 1991, 106-19, fig.3:12</p>	 <p>Cat. 1101</p>

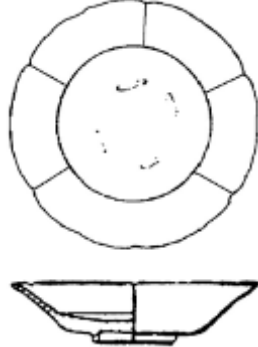

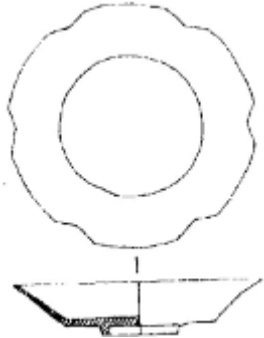
<p>Catalogue No. : Cat. 1102 Type : Bb Body : Porcelain Glaze : white Decoration : Size (cm) : Height: 4; Diameter of mouth: 12.2; Diameter of base: 8.4. Unearthed From : TZM2 (M2:5) Collected By : Date (AD) : middle Published by : Liao Zhenjin & Wang Yi 2004, 31-37.</p>	 <p>Cat. 1102</p>
<p>Catalogue No. : Cat. 1103 Type : Bb Body : Stoneware Glaze : white Decoration : Five lobed mouth Size (cm) : Height: 3.8; Diameter of mouth: 15.6; Diameter of base: 8. Unearthed From : ZJY1 Collected By : Tieling Municipal Museum, Liaoning Date (AD) : early Published by : Pei Yaojun 1996, 57-62, fig.3:2</p>	 <p>Cat. 1103</p>
<p>Catalogue No. : Cat. 1104 Type : Bb Body : Porcelain Glaze : white Decoration : Incised Guan mark under the bottom Size (cm) : Height: 4.6; Diameter of mouth: 15.6. Unearthed From : YMT7 Collected By : Liaoning Provincial Museum Date (AD) : 977 Published by : Liaoningsheng bowuguan et al. 1975, 26-36; Xu Bingkun & Sun Shoudao ed. 1998, 244; Shanghai renmin meishu chubanshe 1986, pl. 45.</p>	  <p>Cat. 1104</p>



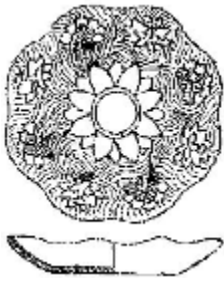

<p>Catalogue No. : Cat. 1105 Type : Bb Body : Porcelain Glaze : white Decoration : Incised Guan mark under the bottom Size (cm) : Height: 4.6; Diameter of mouth: 15.6. Unearthed From : HLDT2 Collected By : Date (AD) : early Published by : Zhang Shaoqing 1988, 819-24, fig.3:2</p>	 <p>Cat. 1105</p>
<p>Catalogue No. : Cat. 1106 Type : Bb Body : Silver Glaze : Decoration : Incised Zuoxianggong inscription Size (cm) : Height: 7.2; Diameter of mouth: 34. Unearthed From : Collected By : Research Institute of Cultural Relics and Archaeology of Inner Mongolia Date (AD) : early Published by : Zhang Jingming 2005, pl. 101.</p>	 <p>Cat. 1106</p>
<p>Catalogue No. : Cat. 1107 Type : Bb Body : Porcelain Glaze : white Decoration : Size (cm) : Height: 2.8; Diameter of mouth: 14; Diameter of base: 4. Unearthed From : MJ1 Collected By : Date (AD) : late Published by : Wan Xin 1999, 15-23, fig.7:2</p>	 <p>Cat. 1107</p>
<p>Catalogue No. : Cat. 1108 Type : Bb Body : Porcelain Glaze : white Decoration : Six lobed mouth Size (cm) : Height: 2.6; Diameter of mouth: 11.4; Diameter of base: 6.5. Unearthed From : ZWZ Collected By : Date (AD) : 1093 Published by : Zheng Shaozong 1996, 14-46, fig.32:9</p>	 <p>Cat. 1108</p>

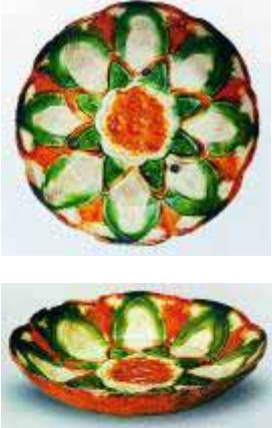
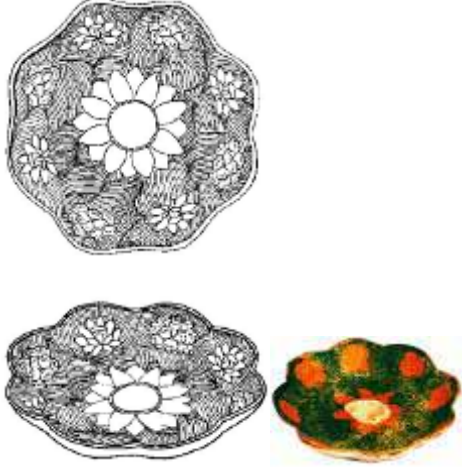

<p>Catalogue No. : Cat. 1109 Type : Bb Body : Porcelain Glaze : white Decoration : Six lobed mouth Size (cm) : Height: 3; Diameter of mouth: 14; Diameter of base: 4.4. Unearthed From : CDMM Collected By : Date (AD) : late Published by : Wang Laizhu 1996, 66-8, fig.3:4</p>	 <p>Cat. 1109</p>
--	---

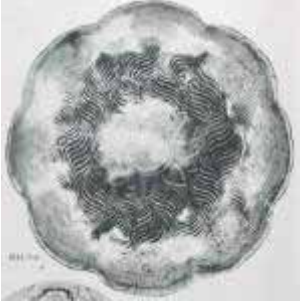

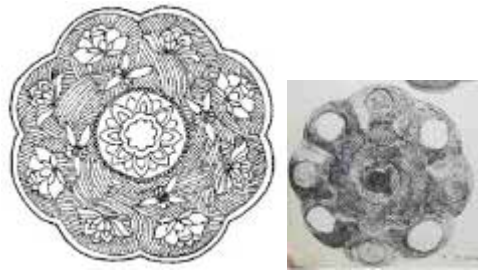
3.20 FLAT-BASE DISH

<p>Catalogue No. : Cat. 1110 Type : A Body : Pinkish earthenware Glaze : Three-colored Decoration : Moulded lotus and water waves designs Size (cm) : Height: 1.5; Diameter of mouth: 10.6. Unearthed From : FZZ Collected By : Date (AD) : late Published by : Ta La & Yiyou 1984, 75-79, fig.3:1</p>	 <p>Cat. 1110</p>
<p>Catalogue No. : Cat. 1111 Type : A Body : Pinkish earthenware Glaze : Three-colored Decoration : Moulded lotus and water waves designs Size (cm) : Height: 2.7; Diameter of mouth: 13.5; Diameter of base: 10. Unearthed From : BL3 Collected By : Date (AD) : late Published by : Wu Jiachang 1986, 32-51, fig.17:3</p>	 <p>Cat. 1111</p>

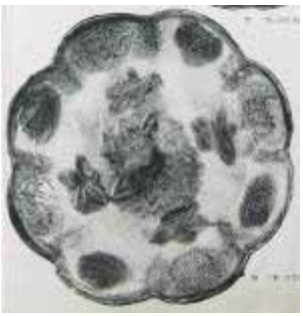
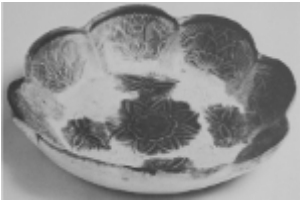



<p>Catalogue No. : Cat. 1112 Type : A Body : Pinkish earthenware Glaze : Three-colored Decoration : Moulded lotus pedals designs Size (cm) : Height: 2.3; Diameter of mouth: 13.3; Diameter of base: 8.7. Unearthed From : Collected By : Liaoning Provincial Museum Date (AD) : late Published by : Zhongguo taoci quanji bianji weiyuanhui 1999, pl. 109; Sugimura Yuzo 1974, pl. 77; Shanhai renmin meishu chubanshe 1986, pl. 40.</p>	 <p>Cat. 1112</p>
<p>Catalogue No. : Cat. 1113 Type : A Body : Pinkish earthenware Glaze : Three-colored Decoration : Moulded lotus and water waves designs Size (cm) : Height: 2.6; Diameter of mouth: 13.3; Diameter of base: 8.7. Unearthed From : A tomb at Zhangjiayingzi, Jianping County, Liaoning Province Collected By : Liaoning Provincial Museum Date (AD) : late Published by : Zhongguo taoci quanji bianji weiyuanhui 1999, pl. 105; Shanhai renmin meishu chubanshe 1986, pl.68; Liaoningsheng bowuguan 1961, pl. 82.</p>	 <p>Cat. 1113</p>
<p>Catalogue No. : Cat. 1114 Type : A Body : Pinkish earthenware Glaze : Three-colored Decoration : Moulded lotus and water waves designs Size (cm) : Diameter of mouth: 13.4. Unearthed From : Collected By : Date (AD) : late Published by : Sugimura Yuzo 1974, pl. 22.</p>	 <p>Cat. 1114</p>

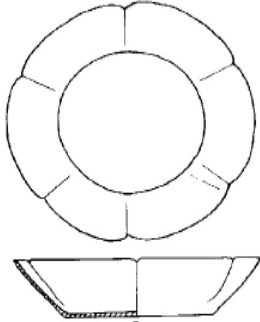
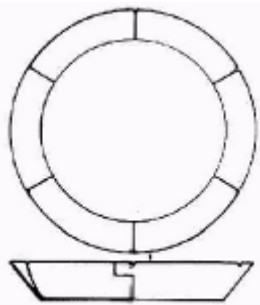

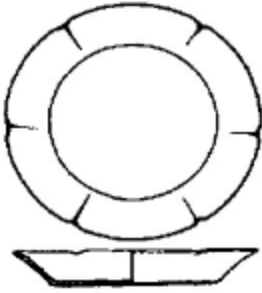
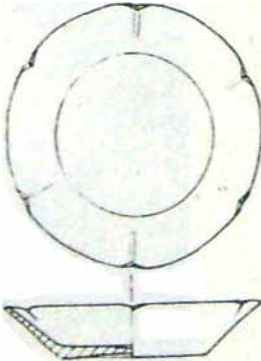
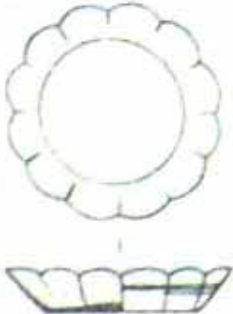
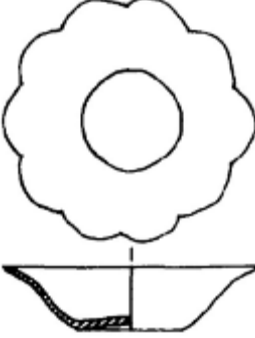
<p>Catalogue No. : Cat. 1115 Type : A Body : Pinkish earthenware Glaze : Three-colored Decoration : Moulded lotus and water waves designs Size (cm) : Diameter of mouth: 13.5. Unearthed From : Collected By : Date (AD) : late Published by : Sugimura Yuzo 1974, pl. 75.</p>	 <p>Cat. 1115</p>
<p>Catalogue No. : Cat. 1116 Type : A Body : Pinkish earthenware Glaze : Three-colored Decoration : Moulded lotus and water waves designs Size (cm) : Height: 2.2; Diameter of mouth: 9.5. Unearthed From : GWYC kiln site Collected By : Guan Baocong collection Date (AD) : late Published by : Lu Jing 2003, pl. 2-42.</p>	 <p>Cat. 1116</p>
<p>Catalogue No. : Cat. 1117 Type : A Body : Pinkish earthenware Glaze : Three-colored Decoration : Moulded lotus and water waves designs Size (cm) : Diameter of mouth: 15.2. Unearthed From : Collected By : Date (AD) : late Published by : Sugimura Yuzo 1974, pl. 76.</p>	 <p>Cat. 1117</p>
<p>Catalogue No. : Cat. 1118 Type : A Body : Pinkish earthenware Glaze : Three-colored Decoration : Moulded lotus and water waves designs Size (cm) : Height: 2.3; Diameter of mouth: 14.2; Diameter of base: 8. Unearthed From : A tomb at Wulanba village, Haoertu township, Balin Left banner, Inner Mongolia Collected By : Liaoshangjing Museum, Inner Mongolia Date (AD) : late Published by : Tang Cailan 2005, pl. 78.</p>	 <p>Cat. 1118</p>

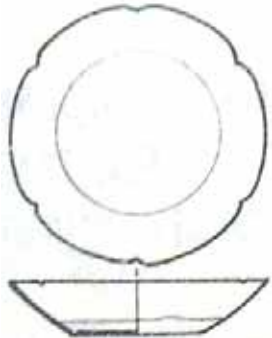
<p>Catalogue No. : Cat. 1119 Type : A Body : Pinkish earthenware Glaze : Three-colored Decoration : Moulded lotus and water waves designs Size (cm) : Diameter of mouth: 14.2. Unearthed From : Collected By : Date (AD) : late Published by : Sugimura Yuzo 1974, pl. 78.</p>	 <p>Cat. 1119</p>
<p>Catalogue No. : Cat. 1120 Type : A Body : Pinkish earthenware Glaze : Three-colored Decoration : Moulded lotus and water waves designs Size (cm) : Height: 3; Diameter of mouth: 12. Unearthed From : Collected By : Center of Asian Art and Culture, Avery Brundage Collection, San Francisco, California Date (AD) : late Published by : Mino Yutaka et al. 1973, pl. 23.</p>	 <p>Cat. 1120</p>
<p>Catalogue No. : Cat. 1121 Type : A Body : Pinkish earthenware Glaze : Three-colored Decoration : Moulded lotus and peony designs Size (cm) : Height: 3.2; Diameter of mouth: 14.8; Diameter of base: 10. Unearthed From : Collected By : Liaoning Provincial Museum Date (AD) : late Published by : Zhongguo taoci quanji bianji weiyuanhui 1999, pl. 111; Shanghai renmin meishu chubanshe 1986, pl.67; Liaoningsheng bowuguan, 1961, pl. 81.</p>	 <p>Cat. 1121</p>
<p>Catalogue No. : Cat. 1122 Type : A Body : Pinkish earthenware Glaze : Three-colored Decoration : Moulded lotus and peony designs Size (cm) : Height: 4; Diameter of mouth: 17; Diameter of base: 6. Unearthed From : Collected By : The Palace Museum, Beijing Date (AD) : late Published by : Zhongguo taoci quanji bianji weiyuanhui 1999, pl. 114.</p>	 <p>Cat. 1122</p>

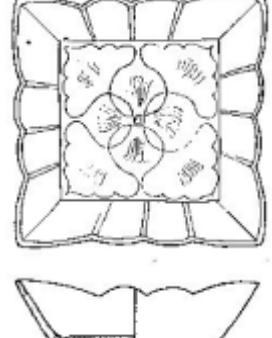

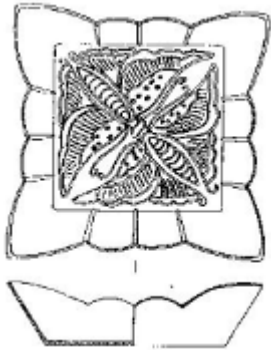
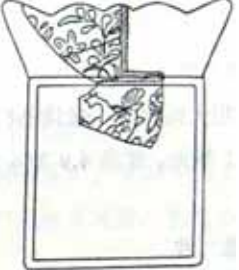

<p>Catalogue No. : Cat. 1123 Type : A Body : Pinkish earthenware Glaze : Three-colored Decoration : Moulded floral designs Size (cm) : Height: 6; Diameter of mouth: 26.4; Diameter of base: 8.3. Unearthed From : Collected By : Private collection, Singapore Date (AD) : late Published by : Lu Jing 2003, pl. 3-599.</p>	 <p>Cat. 1123</p>
<p>Catalogue No. : Cat. 1124 Type : A Body : Porcelain Glaze : white Decoration : Size (cm) : ? Unearthed From : Pagoda Qiyinsi at Xianghe county, Hebei province Collected By : Date (AD) : 1006 Published by : Zhang Zhaoxiang 1989, 137.</p>	 <p>Cat. 1124</p>
<p>Catalogue No. : Cat. 1125 Type : A Body : Porcelain Glaze : white Decoration : Size (cm) : Height: 4.2; Diameter of mouth: 18 Diameter of base: 11. Unearthed From : WJS1 Collected By : Chifeng Municipal Museum Date (AD) : late Published by : Liu Bing et al. 1998, 26-34, 38, fi.2:2</p>	 <p>Cat. 1125</p>
<p>Catalogue No. : Cat. 1126 Type : A Body : Porcelain Glaze : white Decoration : Size (cm) : Height: 2.2; Diameter of mouth: 14.4 Diameter of base: 10.8. Unearthed From : Tomb at Xiyongfeng village, Anci county, Langfang city, Hebei province Collected By : Relics office of Langfang, Hebei province Date (AD) : Published by : Langfang shi wenwu guanlisuo et al. 2001, 38-44, fig.8:1</p>	 <p>Cat. 1126</p>

<p>Catalogue No. : Cat. 1127 Type : A Body : Porcelain Glaze : white Decoration : Size (cm) : Height: 0.9; Diameter of mouth: 11.4 Diameter of base: 7.7. Unearthed From : YS3 Collected By : Date (AD) : Published by : Shao Guotian et al. 1999, 1-38, 43, fig.16:6.</p>	 <p>Cat. 1127</p>
<p>Catalogue No. : Cat. 1128 Type : A Body : Porcelain Glaze : white Decoration : Size (cm) : Diameter of mouth: 11.4. Unearthed From : ZWZ Collected By : Date (AD) : 1093 Published by : Zheng Shaozong 1996, 14-46, fig.32:10.</p>	 <p>Cat. 1128</p>
<p>Catalogue No. : Cat. 1129 Type : A Body : Porcelain Glaze : white Decoration : Size (cm) : Height: 3.2; Diameter of mouth: 18.6. Unearthed From : GS1 Collected By : Date (AD) : late Published by : Jin Fengyi & Xu Ji 1985, 48-55, fig.7:2.</p>	 <p>Cat. 1129</p>
<p>Catalogue No. : Cat. 1130 Type : A Body : Porcelain Glaze : green Decoration : Size (cm) : Height: 6; Diameter of mouth: 26.4; Diameter of base: 8.3. Unearthed From : DPC Collected By : Date (AD) : middle Published by : Liu Junyu & Sun Gang 1999, 31-4, fig.3.</p>	 <p>Cat. 1130</p>



<p>Catalogue No. : Cat. 1131 Type : A Body : Porcelain Glaze : white Decoration : Size (cm) : Height: 2.6-3.4; Diameter of Mouth: 10.6-11.6. Unearthed From : ZGY Collected By : Date (AD) : 1117 Published by : Tao Zongyi et al. 1990, 1-19, fig.10:4</p>	 <p>Cat. 1131</p>
<p>Catalogue No. : Cat. 1132 Type : B Body : Porcelain Glaze : white Decoration : moulded floral designs Size (cm) : Diameter of Mouth: 7.3 Unearthed From : Pagoda BZCT Collected By : Date (AD) : 1051 Published by : Qi Xin & Liu Jingyi 1980, 147-58, fig.13:1</p>	 <p>Cat. 1132</p>
<p>Catalogue No. : Cat. 1133 Type : B Body : Porcelain Glaze : white Decoration : moulded floral designs Size (cm) : Height: 2.9; Diameter of mouth: 11.4. Unearthed From : Pagoda CYBTGG Collected By : Date (AD) : 1043 Published by : Dong Gao & Zhang Hongbo 1992, 1-28, fig.57</p>	 <p>Cat. 1133</p>
<p>Catalogue No. : Cat. 1134 Type : B Body : Porcelain Glaze : white Decoration : moulded butterflies designs Size (cm) : Height: 2.5; Diameter of mouth: 10.3. Unearthed From : Pagoda CYBTGG Collected By : Date (AD) : 1043 Published by : Dong Gao & Zhang Hongbo 1992, 1-28, fig.58</p>	 <p>Cat. 1134</p>



<p>Catalogue No. : Cat. 1135 Type : B Body : Porcelain Glaze : white Decoration : moulded butterflies designs Size (cm) : Height: 2.5; Diameter of mouth: 10.3. Unearthed From : Pagoda CYBTTG Collected By : Date (AD) : 1043 Published by : Dong Gao & Zhang Hongbo 1992, 1-28, fig.24, pl.5:3</p>	 <p>Cat. 1135</p>
<p>Catalogue No. : Cat. 1136 Type : B Body : Porcelain Glaze : white Decoration : moulded floral designs Size (cm) : ? Unearthed From : QHM2 Collected By : Date (AD) : 1057 Published by : Li Wenxin 1954, 163-202, fig. 14:4.</p>	 <p>Cat. 1136</p>
<p>Catalogue No. : Cat. 1137 Type : B Body : Porcelain Glaze : white Decoration : moulded floral designs Size (cm) : ? Unearthed From : Collected By : The Capital Museum, Beijing Date (AD) : Published by : ?</p>	 <p>Cat. 1137</p>
<p>Catalogue No. : Cat. 1138 Type : B Body : Porcelain Glaze : white Decoration : moulded floral designs Size (cm) : Diameter of mouth: 8.3. Unearthed From : Collected By : Museum of Far Eastern Antiquities: Kempe Collection, Stockholm(392) Date (AD) : Published by : Watson 1984, pl. 295.</p>	 <p>Cat. 1138</p>

<p>Catalogue No. : Cat. 1139 Type : B Body : Porcelain Glaze : white Decoration : moulded floral designs Size (cm) : Height: 2.5; Diameter of mouth: 10.6; Diameter of base: 7.. Unearthed From : A tomb at Hadatu Village, Hadayingge Township, Balin Left Banner, Inner Mongolia Collected By : Liaoshangjing Museum, Inner Mongolia Date (AD) : Published by : Tang Cailan 2005, pl. 66.</p>	 <p>Cat. 1139</p>
<p>Catalogue No. : Cat. 1140 Type : B Body : Porcelain Glaze : white Decoration : moulded floral designs Size (cm) : Height: 3.8; Diameter of mouth: 11.5. Unearthed From : Collected By : Art Institute of Chicago: Lucy Maud Buckingham Collection Date (AD) : Published by : Mino Yutaka et al. 1973, pl. 45; Mok 1985, pl. 6.</p>	 <p>Cat. 1140</p>
<p>Catalogue No. : Cat. 1141 Type : B Body : Porcelain Glaze : white Decoration : moulded floral blossom and leaf designs Size (cm) : Height: 2.8; Diameter of mouth: 11.5. Unearthed From : Collected By : The Cleveland Museum of Art, John L. Serverance Fundation Date (AD) : Published by : Mino Yutaka et al. 1973, pl. 44.</p>	 <p>Cat. 1141</p>
<p>Catalogue No. : Cat. 1142 Type : B Body : Porcelain Glaze : white Decoration : Moulded leaf-and-flower designs with duck biting palmette leaf to the right. Size (cm) : Height: 3.2; Diameter of mouth: 11.2. Unearthed From : Collected By : Buffalo Museum of Science Date (AD) : Published by : Mino Yutaka et al. 1973, pl. 42.</p>	 <p>Cat. 1142</p>

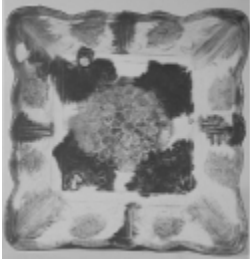
<p>Catalogue No. : Cat. 1143 Type : B Body : Earthenware biscuit mould instrument Glaze : unglazed Decoration : Carved floral designs Size (cm) : Unearthed From : LQW kiln site Collected By : Date (AD) : late Published by : Beijingshi wenwu yanjiusuo 2002, pl.3:3.</p>	 <p>Cat. 1143</p>
<p>Catalogue No. : Cat. 1144 Type : B Body : Pinkish earthenware Glaze : green Decoration : Moulded floral designs Size (cm) : Unearthed From : LQW kiln site Collected By : Date (AD) : late Published by : Beijingshi wenwu yanjiusuo 2002, pl.3:1.</p>	 <p>Cat. 1144</p>
<p>Catalogue No. : Cat. 1145 Type : B Body : Pinkish earthenware Glaze : green Decoration : Moulded floral designs Size (cm) : Unearthed From : LQW kiln site Collected By : Date (AD) : late Published by : Beijingshi wenwu yanjiusuo 2002, pl.3:2.</p>	 <p>Cat. 1145</p>
<p>Catalogue No. : Cat. 1146 Type : B Body : Pinkish earthenware Glaze : Three-colored Decoration : Moulded floral designs Size (cm) : Diameter of mouth: 12.5. Unearthed From : XXZ Collected By : Date (AD) : 1089 Published by : Yan Yu 1960, 34-35, fig.1:3.</p>	 <p>Cat. 1146</p>

<p>Catalogue No. : Cat. 1147 Type : B Body : Pinkish earthenware Glaze : Three-colored Decoration : Moulded floral designs Size (cm) : Diameter of mouth: 12.8. Unearthed From : XPJG Collected By : Date (AD) : late Published by : Zhang Hanying & Bai Guang 1993, 957-58, fig.1:5.</p>	 <p>Cat. 1147</p>
<p>Catalogue No. : Cat. 1148 Type : B Body : Pinkish earthenware Glaze : Three-colored Decoration : Moulded floral designs Size (cm) : Height: 2.8; Diameter of mouth: 12.5; Diameter of base: 8. Unearthed From : XLZZ1 Collected By : Date (AD) : late Published by : Li Yiyou 1961, 44-49, fig.1; Zhongguo taoci quanji bianji weiyuanhui 1999, pl. 112; Neimenggu zizhiqiu wenhuating & Zhongguo lishi bowuguan 2002, pl. 298, 299; Watson 1984, pl. 280; Shen Hsueh-man 2006, pl. 114.</p>	 <p>Cat. 1148</p>
<p>Catalogue No. : Cat. 1149 Type : B Body : Pinkish earthenware Glaze : Three-colored Decoration : Moulded floral designs Size (cm) : Diameter of mouth: 13. Unearthed From : Collected By : Date (AD) : late Published by : Sugimura Yuzo 1974, pl. 19.</p>	 <p>Cat. 1149</p>
<p>Catalogue No. : Cat. 1150 Type : B Body : Pinkish earthenware Glaze : Three-colored Decoration : Moulded floral designs Size (cm) : Diameter of mouth: 12.4. Unearthed From : Collected By : Date (AD) : late Published by : Sugimura Yuzo 1974, pl. 79.</p>	 <p>Cat. 1150</p>

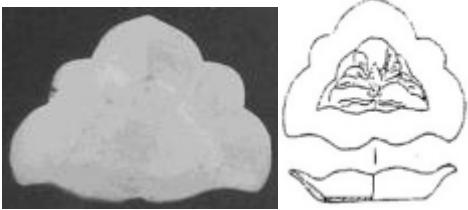

<p>Catalogue No. : Cat. 1151 Type : B Body : Pinkish earthenware Glaze : Three-colored Decoration : Moulded floral designs Size (cm) : Height: 2; Diameter of mouth: 12; Diameter of base: 7.5. Unearthed From : Collected By : The Palace Museum, Beijing Date (AD) : late Published by : Zhongguo taoci quanji bianji weiyuanhui 1999, pl. 103.</p>	 <p>Cat. 1151</p>
<p>Catalogue No. : Cat. 1152 Type : B Body : Pinkish earthenware Glaze : Three-colored Decoration : Moulded floral designs Size (cm) : Height: 3.7; Diameter of mouth: 12.9. Unearthed From : Collected By : Mr. Victor Hauge, Falls Church, Virginia Date (AD) : late Published by : Mino Yutaka et al. 1973, pl. 22.</p>	 <p>Cat. 1152</p>
<p>Catalogue No. : Cat. 1153 Type : B Body : Pinkish earthenware Glaze : Three-colored Decoration : Moulded floral designs Size (cm) : Height: 2.7; Diameter of mouth: 13. Unearthed From : Collected By : Liaoning Provincial Museum Date (AD) : late Published by : Shanghai renmin meishu chubanshe 1986, pl. 11; Liaoningsheng bowuguan 1961, pl. 9.</p>	 <p>Cat. 1153</p>
<p>Catalogue No. : Cat. 1154 Type : B Body : Pinkish earthenware Glaze : Three-colored Decoration : Moulded floral designs Size (cm) : Height: 2.8; Diameter of mouth: 13.1. Unearthed From : Collected By : Liaoning Provincial Museum Date (AD) : late Published by : Shanghai renmin meishu chubanshe 1986, pl. 53.</p>	 <p>Cat. 1154</p>

<p>Catalogue No. : Cat. 1155 Type : B Body : Pinkish earthenware Glaze : Three-colored Decoration : Moulded floral designs Size (cm) : Height: 2.7; Diameter of mouth: 11.4. Unearthed From : Collected By : Chifeng Municipal Museum Date (AD) : late Published by : Shanghai renmin meishu chubanshe 1986, pl. 112.</p>	 <p>Cat. 1155</p>
<p>Catalogue No. : Cat. 1156 Type : B Body : Pinkish earthenware Glaze : Three-colored Decoration : Moulded floral designs Size (cm) : Height: 2.2; Diameter of mouth: 12.5 Unearthed From : Collected By : Chifeng Municipal Museum Date (AD) : late Published by : Shanghai renmin meishu chubanshe 1986, pl. 118.</p>	 <p>Cat. 1156</p>
<p>Catalogue No. : Cat. 1157 Type : B Body : Pinkish earthenware Glaze : Three-colored Decoration : Moulded floral designs Size (cm) : Height: 2.8; Diameter of mouth: 12.5; Diameter of base: 7.7. Unearthed From : Collected By : Liaoning Provincial Museum Date (AD) : late Published by : Liaoningsheng bowuguan 1961, pl. 80.</p>	 <p>Cat. 1157</p>
<p>Catalogue No. : Cat. 1158 Type : C Body : Porcelain Glaze : white Decoration : Moulded butterfly Size (cm) : Diameter of Mouth: 9.5 Unearthed From : A tomb at Changsha, Hunan Province Collected By : Hunan Provincial Museum Date (AD) : Five Dynasties Published by : Gao Zhixi 1984, 84-93, fig. 1:5; Mok 1985, fig.28c.</p>	 <p>Cat. 1158</p>

<p>Catalogue No. : Cat. 1159 Type : C Body : Porcelain Glaze : white Decoration : Moulded butterfly Size (cm) : Diameter of Mouth: 9.3 Unearthed From : Collected By : Museum of Far Eastern Antiquities: Carl Kempe Collection, Stockholm Date (AD) : early Published by : Mok 1985, pl. 07.</p>	 <p>Cat. 1159</p>
<p>Catalogue No. : Cat. 1160 Type : C Body : Silver box Glaze : Decoration : Butterfly designs on the cover Size (cm) : Height: 5; Length: 19. Unearthed From : Dingmaoqiao, Dantu, Jiangsu province Collected By : Date (AD) : Tang Published by : Mok 1985, pl. 8.</p>	 <p>Cat. 1160</p>
<p>Catalogue No. : Cat. 1161 Type : C Body : Amber box Glaze : Decoration : In the form of butterfly Size (cm) : Height: 1.2; Length: 6.6; Width: 4.7. Unearthed From : A tomb at Xiaonuri, Kazuozhong banner, Inner Mongolia Collected By : Tongliao Museum, Inner Mongolia Date (AD) : liao Published by : Wu Yaqin & Wang Ruiqing 2003, 32-5, fig.3:2.</p>	 <p>Cat. 1161</p>
<p>Catalogue No. : Cat. 1162 Type : D Body : Pinkish earthenware Glaze : Three-colored Decoration : Moulder floral designs Size (cm) : Diameter of mouth: 26.4; Diameter of base: 23. Unearthed From : Collected By : Liaoning Provincial Museum Date (AD) : late Published by : Zhongguo taoci quanji bianji weiyuanhui 1999, pl. 110.</p>	 <p>Cat. 1162</p>



<p>Catalogue No. : Cat. 1163 Type : D Body : Pinkish earthenware Glaze : Three-colored Decoration : Moulder floral designs Size (cm) : Diameter of mouth: 15.5. Unearthed From : Collected By : Private collection, Singapore Date (AD) : late Published by : Lu Jing 2003, pl. 3-623.</p>	 <p>Cat. 1163</p>
---	---





3.21 OBLONG-LOBED DISH

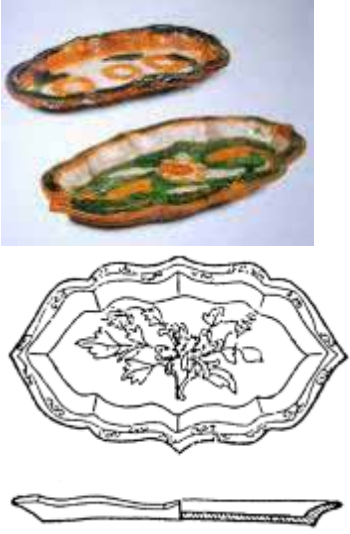

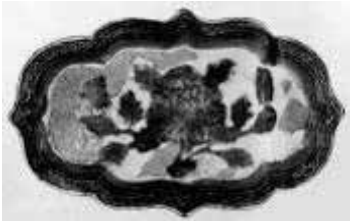

<p>Catalogue No. : Cat. 1164 Type : Mural painting Unearthed From : GYY Date (AD) : 1026 Published by: Zhu Zifang & Xu Ji 1983, 168-195, fig. 13.</p>	 <p>Cat. 1164</p>
<p>Catalogue No. : Cat. 1165 Type : Mural painting Unearthed From : Tomb at Qijia Date (AD) : Published by: Anon 1999, 44-6, 104, fig.19:2.</p>	 <p>Cat. 1165</p>

<p>Catalogue No. : Cat. 1166 Type : Body : silver Glaze : Decoration : Double- Phoenix design Size (cm) : Length: 21. Unearthed From : Collected By : Zhenjiang Museum, Jiangsu Date (AD) : Tang dynasty Published by: Lu Jing 2003, pl. 3-569.</p>	 <p>Cat. 1166</p>
<p>Catalogue No. : Cat. 1167 Type : Body : silver Glaze : Decoration : Swimming fish design Size (cm) : Height: 5; Length: 5.5. Unearthed From : Dingmaoqiao, Dantu, Jiangsu Collected By : Date (AD) : Tang dynasty Published by: Mok 1985, pl. 104.</p>	 <p>Cat. 1167</p>
<p>Catalogue No. : Cat. 1168 Type : Body : silver Glaze : Decoration : Size (cm) : ? Unearthed From : JFYZ Collected By : Date (AD) : late Published by: Xiang Chunsong 1979, 330-34, fig.3.</p>	 <p>Cat. 1168</p>
<p>Catalogue No. : Cat. 1169 Type : Body : silver Glaze : Decoration : Size (cm) : Length: 23.8. Unearthed From : A site of Beiwei at Datong, Shanxi Collected By : Date (AD) : Beiwei Published by: Lu Jing 2003, pl. 3-565.</p>	 <p>Cat. 1169</p>

<p>Catalogue No. : Cat. 1170 Type : Body : Silver Glaze : Decoration : Size (cm) : Length: 29.7. Unearthed From : Collected By : British Museum, London Date (AD) : Tang dynasty Published by: Mok 1985, pl. 103; Lu Jing 2003, pl. 3-570.</p>	 <p>Cat. 1170</p>
<p>Catalogue No. : Cat. 1171 Type : Body : Silver Glaze : Decoration : Size (cm) : Length: 24.8; Width: 18.6. Unearthed From : A tomb at Baiyintala, Keyouhouqi, Inner Mongolia Collected By : Tongliao Museum, Inner Mongolia Date (AD) : Qidan Published by: Ben Heling 2002.</p>	 <p>Cat. 1171</p>
<p>Catalogue No. : Cat. 1172 Type : Body : silver Glaze : Decoration : Size (cm) : Unearthed From : A cathe at Paoziying, Balin Right Banner, Inner Mongolia Collected By : Date (AD) : liao Published by: Waston 1984, 228, fig. 11.</p>	 <p>Cat. 1172</p>
<p>Catalogue No. : Cat. 1173 Type : Body : Gilt silver Glaze : Decoration : Size (cm) : Height: 4.2; Length: 14.8. Unearthed From : Collected By : Inner Mongolia autonomous region museum Date (AD) : Tang Published by: Zhang Jingming 2005 pl. 82.</p>	 <p>Cat. 1173</p>

<p>Catalogue No. : Cat. 1174 Type : Body : Pinkish earthenware Glaze : Three-colored Decoration : Moulded peony designs Size (cm) : Height: 2; Length: 27.5. Unearthed From : XLZZ1 Collected By : Research institute of cultural relics and archaeology of Inner Mongolia Date (AD) : late Published by: Li Yiyou 1961, 44-49, fig.4:5; Shen Hsueh-man 2006, pl. 116a-b.</p>	 <p>Cat. 1174</p>
<p>Catalogue No. : Cat. 1175 Type : Body : Pinkish earthenware Glaze : Three-colored Decoration : Moulded peony designs Size (cm) : Height: 2.1 ; Diameter of mouth: 26-16. Unearthed From : BL3 Collected By : Date (AD) : late Published by: Wu Jiachang 1986, 32-51, fig.17:2.</p>	 <p>Cat. 1175</p>
<p>Catalogue No. : Cat. 1176 Type : Body : Pinkish earthenware Glaze : Three-colored Decoration : Moulded peony designs Size (cm) : Length: 30.8. Unearthed From : PJG3 Collected By : Date (AD) : late Published by: Ji Ping 1997, 639-50, fig.8:5.</p>	 <p>Cat. 1176</p>

<p>Catalogue No. : Cat. 1177 Type : Body : Pinkish earthenware Glaze : Three-colored Decoration : Moulded peony designs Size (cm) : Height: 2.1; Diameter of mouth: 30.1-17.9. Unearthed From : BTYZ Collected By : Liaoning Provincial Museum Date (AD) : late Published by: Zhongguo taoci quanji bianji weiyuanhui 1999, pl. 120; Xu Bingkun & Sun Shoudao ed. 1998, pl. 247; Feng Yongqian 1960, 15-24 ; Shanghai renmin meishu chubanshe 1986, pl. 39; Liaoningsheng bowuguan 1961, pl. 8.</p>	   <p>Cat. 1177</p>
<p>Catalogue No. : Cat. 1178 Type : Body : Pinkish earthenware Glaze : Three-colored Decoration : Moulded peony designs Size (cm) : Length: 26.5. Unearthed From : Collected By : Tokyo National Museum Date (AD) : late Published by: Sugimura Yuzo 1974, pl. 68; Waston 1984, pl. 279.</p>	  <p>Cat. 1178</p>
<p>Catalogue No. : Cat. 1179 Type : Body : Pinkish earthenware Glaze : Three-colored Decoration : Moulded peony designs Size (cm) : Length: 30.3. Unearthed From : Collected By : Ataka collection, Osaka Date (AD) : late Published by: Sugimura Yuzo 1974, pl. 20; Mok 1985, pl. 100.</p>	 <p>Cat. 1179</p>

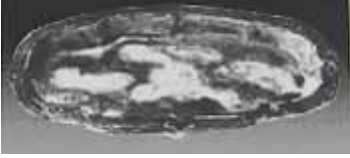
<p>Catalogue No. : Cat. 1180 Type : Body : Pinkish earthenware Glaze : Three-colored Decoration : Moulded peony designs Size (cm) : Height: 2.1; Diameter of mouth: 27.1-16.3; Diameter of base: 22.5-11. Unearthed From : Collected By : Liaoning Provincial Museum Date (AD) : late Published by: Zhongguo taoci quanji bianji weiyuanhui 1999, pl. 107; Liaoningsheng bowuguan 1961, pl. 68.</p>	 <p>Cat. 1180</p>
<p>Catalogue No. : Cat. 1181 Type : Body : Pinkish earthenware Glaze : Three-colored Decoration : Moulded peony designs Size (cm) : Length: 29.7. Unearthed From : Collected By : Tokyo National Museum Date (AD) : late Published by: Sugimura Yuzo 1974, pl. 66.</p>	  <p>Cat. 1181</p>
<p>Catalogue No. : Cat. 1182 Type : Body : Pinkish earthenware Glaze : Three-colored Decoration : Moulded peony designs Size (cm) : Height: 2.5; Length: 27.2. Unearthed From : Collected By : Date (AD) : late Published by: ?</p>	 <p>Cat. 1182</p>
<p>Catalogue No. : Cat. 1183 Type : Body : Pinkish earthenware Glaze : Three-colored Decoration : Moulded lotus, fishes and waves designs Size (cm) : Height: 2.7; Length: 28. Unearthed From : XXZ Collected By : Liaoning provincial museum Date (AD) : 1089 Published by: Yan Yu 1960, 34-35; Liaoningsheng bowuguan 1961, pl. 66.</p>	 <p>Cat. 1183</p>

Catalogue No. : Cat. 1184
 Type :
 Body : Pinkish earthenware
 Glaze : Three-colored
 Decoration : Moulded lotus, fishes and waves designs
 Size (cm) : Height: 2; Length: 26.
 Unearthed From : XLZZ4
 Collected By :
 Date (AD) : late
 Published by: Li Yiyou 1961, 44-49, fig.4:4 ;
 Neimenggu zizhiqu wenhuating & Zhongguo lishi
 bowuguan 2002, pl. 297.

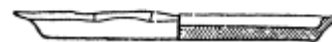





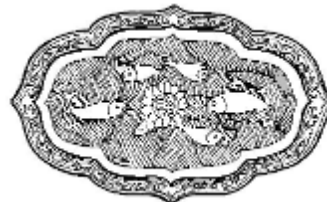

Cat. 1184

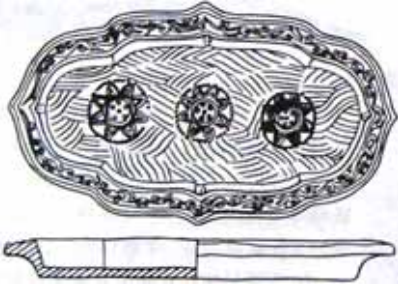
Catalogue No. : Cat. 1185
 Type :
 Body : Pinkish earthenware
 Glaze : Three-colored
 Decoration : Moulded lotus, fishes and waves designs
 Size (cm) : Length: 27.8.
 Unearthed From :
 Collected By : The Museum Yanato Bunkakan, Nara
 大和文华馆
 Date (AD) : late
 Published by: Sugimura Yuzo 1974, pl. 65.





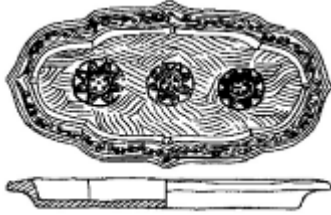

Cat. 1185

<p>Catalogue No. : Cat. 1186 Type : Body : Pinkish earthenware Glaze : Three-colored Decoration : Moulded three lotus rosettes and waves designs Size (cm) : Length: 26.8. Unearthed From : YS3 Collected By : Date (AD) : late Published by: Shao Guotian et al. 1999, 1-38, 43, fig.16:7.</p>	 <p>Cat. 1186</p>
<p>Catalogue No. : Cat. 1187 Type : Body : Pinkish earthenware Glaze : Three-colored Decoration : Moulded three lotus rosettes and waves designs Size (cm) : Height: 2.2; Length: 24.8. Unearthed From : Collected By : Chifeng Municipal Museum Date (AD) : late Published by: Shanghai renmin meishu chubanshe 1986, pl. 119.</p>	 <p>Cat. 1187</p>
<p>Catalogue No. : Cat. 1188 Type : Body : Pinkish earthenware Glaze : Three-colored Decoration : Moulded three lotus rosettes and waves designs Size (cm) : Height: 1.8; Length: 16.9. Unearthed From : Collected By : Chifeng Municipal Museum Date (AD) : late Published by: Shanghai renmin meishu chubanshe 1986, pl. 160.</p>	 <p>Cat. 1188</p>
<p>Catalogue No. : Cat. 1189 Type : Body : Pinkish earthenware Glaze : Three-colored Decoration : Moulded three lotus rosettes and waves designs Size (cm) : Height: 3.1; Length: 30.5. Unearthed From : Collected By : Liaoning provincial museum Date (AD) : late Published by: Liaoningsheng bowuguan 1961, pl. 67.</p>	 <p>Cat. 1189</p>

<p>Catalogue No. : Cat. 1190 Type : Body : Pinkish earthenware Glaze : Three-colored Decoration : Moulded three lotus rosettes and waves designs Size (cm) : ? Unearthed From : GWYC kiln site 95HGF1 Collected By : Date (AD) : late Published by: Peng Shanguo 2003, 113, fig.3-27:1.</p>	 <p>Cat. 1190</p>
<p>Catalogue No. : Cat. 1191 Type : Body : Pinkish earthenware Glaze : Three-colored Decoration : Moulded three lotus rosettes and waves designs Size (cm) : Height: 2.5; Diameter of mouth: 26.8-14.9. Unearthed From : YS3 Collected By : Date (AD) : late Published by: Shao Guotian et al. 1999, 1-38, 43.</p>	 <p>Cat. 1191</p>
<p>Catalogue No. : Cat. 1192 Type : Body : Pinkish earthenware Glaze : Three-colored Decoration : Moulded three lotus rosettes and waves designs Size (cm) : Height: 2.5; Diameter of mouth: 26.2-15.7. Unearthed From : Collected By : Guan Baocong collection Date (AD) : late Published by: Lu Jing 2003, pl. 3-585.</p>	 <p>Cat. 1192</p>
<p>Catalogue No. : Cat. 1193 Type : Body : Pinkish earthenware Glaze : Three-colored Decoration : Moulded three lotus rosettes and waves designs Size (cm) : Height: 2.6; Diameter of mouth: 30.4-17.7. Unearthed From : Collected By : Date (AD) : late Published by: Mok 1985, pl. 101.</p>	 <p>Cat. 1193</p>

<p>Catalogue No. : Cat. 1194 Type : Body : Pinkish earthenware Glaze : Three-colored Decoration : Moulded three lotus rosettes and waves designs Size (cm) : Length: 25.8. Unearthed From : Collected By : 出光美术馆 Date (AD) : late Published by: Sugimura Yuzo 1974, pl. 21.</p>	 <p>Cat. 1194</p>
<p>Catalogue No. : Cat. 1195 Type : Body : Pinkish earthenware Glaze : Three-colored Decoration : Moulded three lotus rosettes and waves designs Size (cm) : Length: 26.2. Unearthed From : Collected By : Date (AD) : late Published by: Sugimura Yuzo 1974, pl. 67.</p>	 <p>Cat. 1195</p>
<p>Catalogue No. : Cat. 1196 Type : Body : Pinkish earthenware Glaze : Three-colored Decoration : Moulded three lotus rosettes and waves designs Size (cm) : Height: 2.5; Diameter of mouth: 25.5-14.5; Diameter of base: 21-10. Unearthed From : Collected By : The Palace Museum, Beijing Date (AD) : late Published by: Zhongguo taoci quanji bianji weiyuanhui 1999, pl. 100.</p>	 <p>Cat. 1196</p>
<p>Catalogue No. : Cat. 1197 Type : Body : Pinkish earthenware Glaze : Three-colored Decoration : Moulded three lotus rosettes and waves designs Size (cm) : Height:2.2 ; Diameter of mouth: 29-16.6. Unearthed From : A tomb at Xigou, Manihan Township, Aohan Banner, Inner Mongolia Collected By : Aohan Banner Museum, Inner Mongolia Date (AD) : late Published by: Shao Guotian ed. 2004, pl. 144.</p>	 <p>Cat. 1197</p>

<p>Catalogue No. : Cat. 1198 Type : Body : Pinkish earthenware Glaze : Three-colored Decoration : Moulded lotus rosettes designs Size (cm) : Height: 2.5; Diameter of mouth: 25.5-19.5. Unearthed From : Collected By : ? Date (AD) : late Published by: Lu Jing 2003, pl. 3-586.</p>	 <p>Cat. 1198</p>
<p>Catalogue No. : Cat. 1199 Type : Body : Pinkish earthenware Glaze : Three-colored Decoration : Moulded lotus rosettes designs Size (cm) : Height: 1.8; Lenth: 24.8. Unearthed From : Collected By : Liaoning Tieling qunzhongyishuguan wenwuzu Date (AD) : late Published by: Shanghai renmin meishu chubanshe 1986, pl. 109.</p>	 <p>Cat. 1199</p>
<p>Catalogue No. : Cat. 1200 Type : Body : Pinkish earthenware Glaze : Three-colored Decoration : Moulded lotus rosettes designs Size (cm) : Height: 2.5; Lenth: 26.5. Unearthed From : Collected By : Liaoning Provincial Museum Date (AD) : late Published by: Shanghai renmin meishu chubanshe 1986, pl. 163.</p>	 <p>Cat. 1200</p>
<p>Catalogue No. : Cat. 1201 Type : Body : Pinkish earthenware Glaze : Three-colored Decoration : Moulded lotus rosettes designs Size (cm) : Height: 2.4; Lenth: 24.7. Unearthed From : Collected By : Liaoning Provincial Museum Date (AD) : late Published by: Liaoningsheng bowuguan 1961, pl. 69.</p>	 <p>Cat. 1201</p>

3.22 INKSTONE AND BRUSH-WASHER

<p>Catalogue No. : Cat. 1202 Type : A Body : stonware Glaze : white Decoration : Brush washer decorated with moulded leaves design Size (cm) : Diameter: 22. Unearthed From : DYZ3 Collected By : Date (AD) : middle Published by: Zheng Shaozong 1956, 1-26, pl. 7:4.</p>	 <p>Cat. 1202</p>
<p>Catalogue No. : Cat. 1203 Type : A Body : Pinkish earthenware Glaze : Three-colored Decoration : Brush washer basin decorated with moulded floral designs Size (cm) : Height: 8.4; Diameter: 21. Unearthed From : BTYZ Collected By : Liaoning Provincial Museum Date (AD) : late Published by: Feng Yongqian, 1960, 15-24; Zhongguo taoci quanji bianji weiyuanhui 1999, pl. 108; Shanghai renmin meishu chubanshe 1986, pl. 52; Liaoningsheng bowuguan 1961, pl.11.</p>	 <p>Cat. 1203</p>
<p>Catalogue No. : Cat. 1204 Type : A Body : Pinkish earthenware Glaze : Three-colored Decoration : Inkstone and brush-washer Combination decorated with moulded floral scroll designs Size (cm) : Height: 8; Diameter: 23. Unearthed From : SFC Collected By : Inner Mongolia autonomous region museum Date (AD) : 1066 Published by: Neimenggu zizhiqu wenhuating & Zhongguo lishi bowuguan 2002, pl. 306.</p>	 <p>Cat. 1204</p>

<p>Catalogue No. : Cat. 1205 Type : A Body : Pinkish earthenware Glaze : Three-colored Decoration : Brush washer decorated with moulded floral designs Size (cm) : Height: 8. Unearthed From : Collected By : Date (AD) : late Published by: ?</p>	 <p>Cat. 1205</p>
<p>Catalogue No. : Cat. 1206 Type : A Body : Pinkish earthenware Glaze : Three-colored Decoration : Inkstone decorated with moulded floral designs. With flowers and leaves in relief, the sides divided into six panels and the edges of the pool lobed. Size (cm) : Height: .6.6; Diameter: 18.3. Unearthed From : Collected By : Museum für Ostasiatische Kunst, Staatliche Museen Preussischer Kuterbesitz, Berlin Date (AD) : late Published by: Waston 1984, pl. 265; Mino Yutaka et al. 1973, pl. 33; Mok 1985, pl. 34.</p>	 <p>Cat. 1206</p>
<p>Catalogue No. : Cat. 1207 Type : A Body : Pinkish earthenware Glaze : Three-colored Decoration : Inkstone decorated with moulded floral designs. Size (cm) : Height: .6.6; Diameter: 18.3. Unearthed From : Collected By : Tokyo National Museum Date (AD) : late Published by: Sugimura Yuzo 1974, pl. 63.</p>	 <p>Cat. 1207</p>
<p>Catalogue No. : Cat. 1208 Type : A Body : Pinkish earthenware Glaze : Three-colored Decoration : Inkstone decorated with moulded floral designs. Size (cm) : Height: .7.5; Diameter: 19.8. Unearthed From : Collected By : Private collection , Singapore Date (AD) : late Published by: Lu Jing 2003, pl. 3-633.</p>	 <p>Cat. 1208</p>

<p>Catalogue No. : Cat. 1209 Type : A Body : Pinkish earthenware Glaze : Three-colored Decoration : Inkstone decorated with moulded floral designs. Size (cm) : Height: .6; Diameter: 20. Unearthed From : Collected By : Private collection Date (AD) : late Published by: Lu Jing 2003, pl. 3-631.</p>	 <p>Cat. 1209</p>
<p>Catalogue No. : Cat. 1210 Type : A Body : Pinkish earthenware Glaze : Three-colored Decoration : Inkstone and brush-washer combination decorated with moulded floral designs. Size (cm) : Height: .8; Diameter: 21.9. Unearthed From : A tomb at Shifo Township, Ningcheng County, Inner Mongolia Collected By : Ningcheng Museum, Inner Mongolia Date (AD) : late Published by: Neimenggu zizhiqu wenhuating & Zhongguo lishi bowuguan 2002, pl. 305; Shen Hsueh-man 2006, pl. 115a.</p>	 <p>Cat. 1210</p>
<p>Catalogue No. : Cat. 1211 Type : A Body : Pinkish earthenware biscuit Glaze : Decoration : Inkstone decorated with moulded floral designs. Size (cm) : Height: .6.7; Diameter: 21.9. Unearthed From : GWYC kiln site Collected By : Research institute of culatural relics and archaeology of Inner Mongolia Date (AD) : late Published by: Neimenggu zizhiqu wenhuating & Zhongguo lishi bowuguan 2002, pl. 307; Shen Hsueh-man 2006, pl. 115c.</p>	 <p>Cat. 1211</p>

Catalogue No. : Cat. 1212
 Type : A
 Body : Pinkish earthenware
 Glaze : Three-colored
 Decoration : Inkstone and brush-washer combination decorated with moulded floral designs.
 Size (cm) : Height: 7.2; Diameter: 18.1.
 Unearthed From :
 Collected By : Chifeng municipal museum, Inner Mongolia
 Date (AD) : late
 Published by: Shanghai renmin meishu chubanshe 1986, pl. 61.



Cat. 1212

Catalogue No. : Cat. 1213
 Type : B
 Body : Pinkish earthenware
 Glaze : Three-colored
 Decoration : Brush washer decorated with moulded human and animal designs.
 Size (cm) : Height: 9.5; Diameter: 23.4.
 Unearthed From : XLZZ3
 Collected By : Inner Mongolia autonomous region museum
 Date (AD) : late
 Published by: Zhongguo taoci quanji bianji weiyuanhui 1999, pl. 123; Neimenggu zizhiq wenhuating & Zhongguo lishi bowuguan 2002, pl. 300.





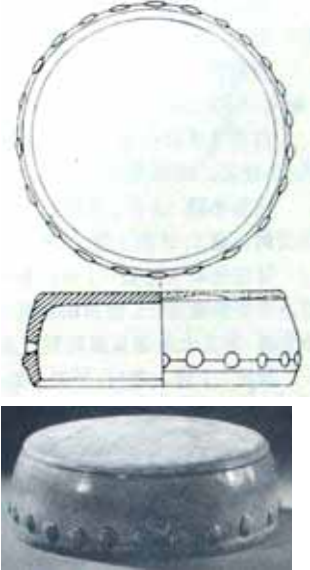

Cat. 1213





<p>Catalogue No. : Cat. 1214 Type : B Body : Pinkish earthenware Glaze : Three-colored Decoration : Inkstone and brush-washer combination decorated with moulded floral designs. Size (cm) : Height: 12.6; Diameter: 22. Unearthed From : XTM(MWG3) Collected By : Research institute of cultural relics and archaeology of Inner Mongolia Date (AD) : 1070 Published by: Ji Ping & Ta La 1997, 609-30; Neimenggu zizhiqiu wenhuating & Zhongguo lishi bowuguan 2002, pl.303; Shanghai bowuguan 2000, pl. 187; Shen Hsueh-man 2006, pl. 115b.</p>	 <p>Cat. 1214</p>
<p>Catalogue No. : Cat. 1215 Type : B Body : Pinkish earthenware Glaze : Three-colored Decoration : Inkstone decorated with moulded floral designs. Size (cm) : Height: 9.2; Diameter: 25.2. Unearthed From : Collected By : Private collection Date (AD) : late Published by: Lu Jing 2003, pl. 3-637.</p>	 <p>Cat. 1215</p>
<p>Catalogue No. : Cat. 1216 Type : B Body : Pinkish earthenware Glaze : Three-colored Decoration : Inkstone decorated with moulded floral designs. Size (cm) : Height: 6.7; Diameter: 17.2. Unearthed From : Collected By : Private collection Date (AD) : late Published by: Lu Jing 2003, pl. 3-638.</p>	 <p>Cat. 1216</p>

<p>Catalogue No. : Cat. 1217 Type : B Body : Pinkish earthenware Glaze : Three-colored Decoration : Brush washer decorated with moulded relief ornaments of animal mask designs. Size (cm) : Diameter: 19. Unearthed From : Collected By : Matsuoka Art Museum, Tokyo Date (AD) : Published by: Mok 1985, pl. 131.</p>	 <p>Cat. 1217</p>
<p>Catalogue No. : Cat. 1218 Type : C Body : Pinkish earthenware Glaze : yellow Decoration : decorated with applied rivet designs in relief Size (cm) : Height: 9.2; Diameter: 25.2. Unearthed From : BTYZ Collected By : Date (AD) : late Published by: Feng Yongqian 1960, 15-24, fig.10-2; Liaoningsheng bowuguan 1961, pl. 107.</p>	 <p>Cat. 1218</p>





3.23 OCARINA

<p>Catalogue No. : Cat. 1219 Type : A Body : Pinkish earthenware Glaze : Three-colored Decoration : Moulded floral designs Size (cm) : Height: 6.4; Diameter of belly: 8.5. Unearthed From : Collected By : The Palace Museum, Beijing Date (AD) : late Published by: Zhongguo taoci quanji bianji weiyuanhui 1999, pl. 102.</p>	 <p>Cat. 1219</p>
---	---





<p>Catalogue No. : Cat. 1220 Type : A Body : Pinkish earthenware Glaze : Three-colored Decoration : Moulded floral designs Size (cm) : Height: 6.5; Diameter of belly: 8. Unearthed From : Collected By : Chifeng Municipal Museum Date (AD) : late Published by: Zhongguo taoci quanji bianji weiyuanhui 1999, pl. 115.</p>	 <p>Cat. 1220</p>
<p>Catalogue No. : Cat. 1221 Type : A Body : Pinkish earthenware Glaze : Three-colored Decoration : Moulded floral designs Size (cm) : Height: 6.3; Diameter of belly: 8.3. Unearthed From : XTM(MWG3) Collected By : Research institute of cultural relics and archaeology of Inner Mongolia Date (AD) : 1071 Published by: Ji Ping & Ta La 1997, 609-30, fig.17:1; Neimenggu zizhiqu wenhuating & Zhongguo lishi bowuguan 2002, pl. 290; Shanghai bowuguan 2000, pl. 188.</p>	  <p>Cat. 1221</p>
<p>Catalogue No. : Cat. 1222 Type : A Body : Pinkish earthenware Glaze : yellow Decoration : Size (cm) : Height: 6.2; Diameter of belly: 6.8. Unearthed From : A tomb at Yaojiagou, Jinchanggouliang Township, Aohan Banner, Inner Mongolia Collected By : Aohan Banner Museum, Inner Mongolia Date (AD) : late Published by: Shao Guotian ed. 2004, pl. 151.</p>	 <p>Cat. 1222</p>

<p>Catalogue No. : Cat. 1223 Type : A Body : Pinkish earthenware Glaze : Three-colored Decoration : Moulded floral designs Size (cm) : Height: 5.8; Diameter of belly: 8.2. Unearthed From : A tomb at Songsshan district, Chifeng city, Inner Mongolia Collected By : Chifeng Municipal Museum, Inner Mongolia Date (AD) : late Published by: Zhongguo taoci quanji bianji weiyuanhui 1999, pl. 97.</p>	 <p>Cat. 1223</p>
<p>Catalogue No. : Cat. 1224 Type : A Body : Pinkish earthenware Glaze : Three-colored Decoration : Moulded floral designs Size (cm) : Height: 6.5; Diameter of belly: 8.5. Unearthed From : XLZZ1 Collected By : Date (AD) : late Published by: Li Yiyou 1961, 44-49, fig.4:7.</p>	 <p>Cat. 1224</p>
<p>Catalogue No. : Cat. 1225 Type : A Body : Pinkish earthenware Glaze : Decoration : Moulded floral designs in relief Size (cm) : Height: 7; Diameter of belly: 8. Unearthed From : A tomb at Yuanbao district, Chifeng city, Inner Mongolia Collected By : Chifeng Municipal Museum, Inner Mongolia Date (AD) : late Published by: Zhongguo taoci quanji bianji weiyuanhui 1999, pl. 4; Shanghai renmin meishu chubanshe 1986, pl. 161.</p>	 <p>Cat. 1225</p>
<p>Catalogue No. : Cat. 1226 Type : A Body : Pinkish earthenware biscuit Glaze : Decoration : Moulded floral designs in relief Size (cm) : Height: 3.8. Unearthed From : GWYC kiln site Collected By : Guan Baocong collection Date (AD) : late Published by: Lu Jing 2003, pl. 2-44.</p>	 <p>Cat. 1226</p>

<p>Catalogue No. : Cat. 1227 Type : A Body : Pinkish earthenware Glaze : green Decoration : Size (cm) : Height: 6. Unearthed From : A tomb at Linchang, Longchang Township, Balin Left Banner, Inner Mongolia Collected By : LiaoShangjing museum, Inner Mongolia Date (AD) : late Published by: Tang Cailan 2005, pl. 82.</p>	 <p>Cat. 1227</p>
<p>Catalogue No. : Cat. 1228 Type : A Body : Pinkish earthenware Glaze : Three-colored Decoration : Moulded floral designs Size (cm) : Height: 7. Unearthed From : Collected By : Private collection, Sincapore Date (AD) : late Published by: Lu Jing 2003, pl. 3-658.</p>	 <p>Cat. 1228</p>
<p>Catalogue No. : Cat. 1229 Type : A Body : Pinkish earthenware Glaze : Three-colored Decoration : Moulded floral designs Size (cm) : Height: 6.3; Diameter of belly: 7.1. Unearthed From : Collected By : Private collection Date (AD) : late Published by: Lu Jing 2003, pl. 3-.660</p>	 <p>Cat. 1229</p>
<p>Catalogue No. : Cat. 1230 Type : A Body : Pinkish earthenware Glaze : Three-colored Decoration : Moulded floral designs Size (cm) : Height: 6.5; Diameter of belly: 7.5. Unearthed From : Collected By : Private collection Date (AD) : late Published by: Lu Jing 2003, pl. 3-661.</p>	 <p>Cat. 1230</p>

<p>Catalogue No. : Cat. 1231 Type : A Body : Pinkish earthenware Glaze : Three-colored Decoration : Moulded floral designs Size (cm) : Height: 8.5; Diameter of belly: 13.2. Unearthed From : A tomb at Sidetang Township, Aohan Banner, Inner Mongolia Collected By : Aohan Banner Museum Date (AD) : late Published by: Shao Guotian ed. 2004, pl. 153.</p>	 <p>Cat. 1231</p>
<p>Catalogue No. : Cat. 1232 Type : B Body : stoneware Glaze : white Decoration : Pig head shaped Size (cm) : Height: 4.4; Diameter: 5. Unearthed From : GWYC kiln site Collected By : Guan Baocong collection Date (AD) : late Published by: Lu Jing 2003, pl. 3-665.</p>	 <p>Cat. 1232</p>
<p>Catalogue No. : Cat. 1233 Type : B Body : stoneware Glaze : brown Decoration : Ox head shaped Size (cm) : Height: 5.5. Unearthed From : The Hancheng site of Shangjing, Balin Left Banner, Inner Mongolia Collected By : Liaoshangjing Museum, Inner Mongolia Date (AD) : late Published by: Tang Cailan 2005, pl. 82.</p>	 <p>Cat. 1233</p>
<p>Catalogue No. : Cat. 1234 Type : B Body : stoneware Glaze : white Decoration : Pig head shaped Size (cm) : Height: 6.2. Unearthed From : GWYC kiln site Collected By : Liaoning provincial museum Date (AD) : late Published by: Zhongguo taoci quanji bianji weiyuanhui 1999, pl. 35.</p>	 <p>Cat. 1234</p>

<p>Catalogue No. : Cat. 1235 Type : B Body : stoneware Glaze : white Decoration : Animal head shaped Size (cm) : ? Unearthed From : LQW kiln site Collected By : Date (AD) : late Published by: Beijingshi wenwu yanjiusuo 2002.</p>	 <p>Cat. 1235</p>
<p>Catalogue No. : Cat. 1236 Type : B Body : stoneware Glaze : brown Decoration : Ox head shaped Size (cm) : Height: 5. Unearthed From : GGT kiln site Collected By : Guan Baocong collection Date (AD) : late Published by: Lu Jing 2003, pl. 3-666.</p>	 <p>Cat. 1236</p>
<p>Catalogue No. : Cat. 1237 Type : B Body : stoneware Glaze : white Decoration : Pig head shaped Size (cm) : Height: 6.2. Unearthed From : GWYC kiln site Collected By : Lianing provincial museum Date (AD) : late Published by: Lu Jing 2003, pl. 3-664.</p>	 <p>Cat. 1237</p>
<p>Catalogue No. : Cat. 1238 Type : B Body : stoneware Glaze : brown Decoration : Ox head shaped Size (cm) : Height: 4.8. Unearthed From : GGT kiln site Collected By : Guan Baocong collection Date (AD) : late Published by: Lu Jing 2003, pl. 3-662.</p>	 <p>Cat. 1238</p>
<p>Catalogue No. : Cat. 1239 Type : B Body : stoneware Glaze : white Decoration : Ox head shaped Size (cm) : Height: 8. Unearthed From : GGT kiln site Collected By : Guan Baocong collection Date (AD) : late Published by: Lu Jing 2003, pl. 3-666.</p>	 <p>Cat. 1239</p>

<p>Catalogue No. : Cat. 1240 Type : B Body : stoneware Glaze : white Decoration : Animal head shaped Size (cm) : Height: 5. Unearthed From : GWYC kiln site Collected By : Guan Baocong collection Date (AD) : late Published by: Lu Jing 2003, pl. 3-663.</p>	 <p>Cat. 1240</p>
<p>Catalogue No. : Cat. 1241 Type : B Body : stoneware Glaze : brown Decoration : Ox head shaped Size (cm) : Height: 4.3. Unearthed From : GGT kiln site Collected By : Guan Baocong collection Date (AD) : late Published by: Lu Jing 2003, pl. 4-90, 91.</p>	 <p>Cat. 1241</p>
<p>Catalogue No. : Cat. 1242 Type : C Body : Pinkish earthenware Glaze : Three-colored Decoration : Cat shape Size (cm) : Height: 7; Length: 10. Unearthed From : HPYZ1 Collected By : Relics office of Songshan district, Chifeng city, Inner Mongolia Date (AD) : late Published by: Xiang Chunsong 1991, 33-39, fig.5:4; Neimenggu zizhiqu wenhuating & Zhongguo lishi bowuguan 2002, pl. 291; Zhongguo taoci quanji bianji weiyuanhui 1999, pl. 116.</p>	  <p>Cat. 1242</p>
<p>Catalogue No. : Cat. 1243 Type : C Body : Pinkish earthenware Glaze : Three-colored Decoration : Cat shape Size (cm) : Height: 6.3; Length: 9.8. Unearthed From : Collected By : Liaoning Provincial Museum Date (AD) : late Published by: Zhongguo taoci quanji bianji weiyuanhui 1999, pl. 117; Xu Bingkun & Sun Shoudao ed. 1998, pl. 245.</p>	 <p>Cat. 1243</p>

<p>Catalogue No. : Cat. 1244 Type : C Body : Pinkish earthenware Glaze : White Decoration : Cat shape Size (cm) : Height: 8; Length: 12. Unearthed From : Collected By : Liaoning Provincial Museum Date (AD) : late Published by: Lu Jing 2003, pl. 3-215.</p>	 <p>Cat. 1244</p>
--	---

3.24 PILLOW

<p>Catalogue No. : Cat. 1245 Type : A Body : Pinkish earthenware Glaze : yellow Decoration : Carved human and birds designs Size (cm) : Height: 8.6; Length: 16; Width: 8.6. Unearthed From : ELC Collected By : Date (AD) : middle Published by: Zhang Baizhong 1985, 56-62, fig.4:3.</p>	 <p>Cat. 1245</p>
<p>Catalogue No. : Cat. 1246 Type : A Body : Stoneware Glaze : white Decoration : Carved deer and butterflies designs Size (cm) : Height: 10.5; Length: 20.4; Width: 11.7-12.3. Unearthed From : HLC1 Collected By : Date (AD) : early Published by: He Yong & Pang Ruixiang 1990, 21-6, fig.1:2.</p>	 <p>Cat. 1246</p>
<p>Catalogue No. : Cat. 1247 Type : A Body : Stoneware Glaze : green Decoration : Carved human and birds designs Size (cm) : Height: 11.3; Length: 25. Unearthed From : A tomb at Wulan village, Xinhui Township, Aohan Banner, Inner Mongolia Collected By : Chifeng Municipal Museum Date (AD) : early Published by: Zhongguo taoci quanji bianji weiyuanhui 1999, pl. 78; anhai renmin meishu chubanshe 1986, pl. 133.</p>	 <p>Cat. 1247</p>



<p>Catalogue No. : Cat. 1248 Type : A Body : Pinkish earthenware Glaze : green Decoration : Impressed floral designs Size (cm) : Unearthed From : Dahuangye kiln site, Gongyi, Hebei province Collected By : Date (AD) : 1159 Published by: ?</p>	 <p>Cat. 1248</p>
<p>Catalogue No. : Cat. 1249 Type : A Body : Stoneware Glaze : white Decoration : Incised designs Size (cm) : Height: 10.2; Length: 20; Width: 10.5. Unearthed From : A tomb at Banbu village, Baiyinaobao Township, Balin Left Banner, Inner Mongolia Collected By : Liaoshangjing museum, Inner Mongolia Date (AD) : Published by: Tang Cailan 2005, pl. 70.</p>	 <p>Cat. 1249</p>
<p>Catalogue No. : Cat. 1250 Type : A Body : Pinkish earthenware Glaze : green Decoration : Impressed designs Size (cm) : Height: 9.1; Width: 11.1. Unearthed From : HTH1 Collected By : Research institute of cultural relics and archaeology of Inner Mongolia Date (AD) : middle Published by: Zhongguo shekeyuan neimenggu gongzuodui et al. 2003, 3-14, fig.7:5.</p>	 <p>Cat. 1250</p>
<p>Catalogue No. : Cat. 1251 Type : A Body : stoneware Glaze : ? Decoration : Size (cm) : ? Unearthed From : LQW kiln site Collected By : Date (AD) : Published by: Beijingshi wenwu yanjiusuo 2002, 286.</p>	 <p>Cat. 1251</p>



<p>Catalogue No. : Cat. 1252 Type : A Body : stoneware Glaze : white Decoration : Incised peony designs Size (cm) : Height: 10.1; Length: 20.2; Width: 10.9. Unearthed From : Collected By : Aohan Banner Museum, Inner Mongolia Date (AD) : Published by: Shao Guotian ed. 2004, pl. 152-1.</p>	 <p>Cat. 1252</p>
<p>Catalogue No. : Cat. 1253 Type : B Body : Porcelaneous stoneware Glaze : white Decoration : In the form of a tiger Size (cm) : Height: 9.4; Length: 15.5; Width: 12.8. Unearthed From : A tomb at Buhetehada, Bayanerdeng sumu, Balin ringht Banner, Inner Mongolia Collected By : Baolin Right Banner Museum, Inner Mongolia Date (AD) : Published by: Neimenggu zizhiqu wenhuating & Zhongguo lishi bowuguan 2002, pl. 275; Shen Hsueh-man 2006, pl. 111.</p>	 <p>Cat. 1253</p>
<p>Catalogue No. : Cat. 1254 Type : B Body : Stoneware Glaze : white Decoration : In the form of a tiger Size (cm) : Height: 10.8; Length: 20.3. Unearthed From : Collected By : Date (AD) : Published by: Lu Jing 2003 pl. 3-672.</p>	 <p>Cat. 1254</p>
<p>Catalogue No. : Cat. 1255 Type : B Body : Stoneware Glaze : white Decoration : Brown iron pigment painted; In the form of a tiger. Size (cm) : Height: 14; Length: 32; Width: 14. Unearthed From : A tomb at Guojia village, Xidayingzi Township, Chaoyang city, Liaoning Province Collected By : Liaoning Provincial Museum Date (AD) : late Published by: Zhongguo taoci quanji bianji weiyuanhui 1999, pl. 46.</p>	 <p>Cat. 1255</p>

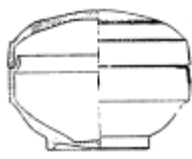

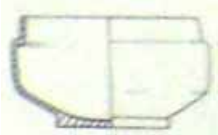
<p>Catalogue No. : Cat. 1256 Type : C Body : stonware Glaze : whtie Decoration : Incised lotus design Size (cm) : Height: 12.7; Length: 28; Width: 17.4. Unearthed From : Collected By : Aohan Banner Museum, Inner Mongolia Date (AD) : late Published by: Shao Guotian ed. 2004, pl. 152-2.</p>	 <p>Cat. 1256</p>
<p>Catalogue No. : Cat. 1257 Type : C Body : stonware Glaze : black Decoration : Size (cm) : Height: 13; Length: 25; Width: 20 Unearthed From : Collected By : Guan Baocong collection Date (AD) : late Published by: Lu Jing 2003, pl. 4-121.</p>	 <p>Cat. 1257</p>
<p>Catalogue No. : Cat. 1258 Type : D Body : Pinkish earthenware biscuit Glaze : Decoration : Moulded designs Size (cm) : ? Unearthed From : LQW kiln site Collected By : Date (AD) : Published by: Beijingshi wenwu yanjiusuo 2002, pl.8:3.</p>	 <p>Cat. 1258</p>

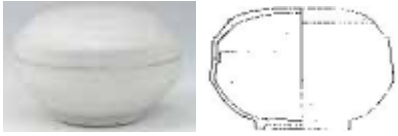
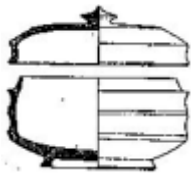
3.25 Box

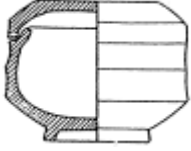
<p>Catalogue No. : Cat. 1259 Type : A Body : porcelain Glaze : white Decoration : Size (cm) : Height: 17.7 Unearthed From : HLB1 Collected By : Date (AD) : early Published by: Li Yufeng 1991, 106-119, fig.3:16.</p>	 <p>Cat. 1259</p>
---	---

<p>Catalogue No. : Cat. 1260 Type : A Body : porcelain Glaze : white Decoration : Size (cm) : ? Unearthed From : BS1 Collected By : Date (AD) : 923 Published by: Qi Xiaoguang et al. 1998, 73-95, fig.11:2.</p>	 <p>Cat. 1260</p>
<p>Catalogue No. : Cat. 1261 Type : A Body : porcelain Glaze : white Decoration : Size (cm) : Height: 6; Diameter of mouth: 9; Diameter of belly: 10.4; Diameter of base: 4.5. Unearthed From : TZM2:4 Collected By : Date (AD) : middle Published by: Liao Zhenjin & Wang Yi 2004, 31-37.</p>	 <p>Cat. 1261</p>
<p>Catalogue No. : Cat. 1262 Type : A Body : porcelain Glaze : white Decoration : Size (cm) : Height: 9.3; Diameter of mouth: 12.6; Diameter of belly: 14.2; Diameter of base: 7.2. Unearthed From : CGGZ Collected By : Research institute of cultural relics and archaeology of Inner Mongolia Date (AD) : 1018 Published by: Neimenggu wenwu kaogu yanjiusuo et al. 1993; Neimenggu zizhiqu wenhuating & Zhongguo lishi bowuguan 2002, pl. 243.</p>	 <p>Cat. 1262</p>
<p>Catalogue No. : Cat. 1263 Type : A Body : porcelain Glaze : white Decoration : Size (cm) : ? Unearthed From : Pagoda JGS Collected By : Date (AD) : 1013 Published by: Su Tianjun 1964, 49-53.</p>	 <p>Cat. 1263</p>

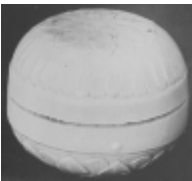
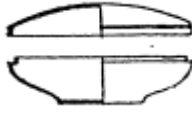
<p>Catalogue No. : Cat. 1264 Type : A Body : porcelain Glaze : white Decoration : Size (cm) : Height: 6. Unearthed From : WZM Collected By : Date (AD) : 1053 Published by: Beijingshi wenwu guanlichu 1972, 35-49, pl.12:2.</p>	 <p>Cat. 1264</p>
<p>Catalogue No. : Cat. 1265 Type : A Body : porcelain Glaze : white Decoration : Size (cm) : Height: 5.8. Unearthed From : YMT3 Collected By : Date (AD) : late Published by: Feng Yongqian 1994, 163-90, fig.4:6.</p>	 <p>1 Cat. 1265</p>
<p>Catalogue No. : Cat. 1266 Type : A Body : porcelain Glaze : white Decoration : Size (cm) : Height: 6.6; Diameter of mouth: 11.3; Diameter of base: 5.4. Unearthed From : Tomb at Yaojiagou, Jinchanggouliang Township, Aohan Banner, Inner Mongolia Collected By : Aohan Banner Museum Date (AD) : Published by: Shao Guotian ed. 2004. Pl. 145.</p>	 <p>Cat. 1266</p>
<p>Catalogue No. : Cat. 1267 Type : A Body : porcelain Glaze : white Decoration : Incised designs Size (cm) : Unearthed From : Collected By : Guan Baocong collection Date (AD) : Published by: unpublished</p>	 <p>Cat. 1267</p>

<p>Catalogue No. : Cat. 1268 Type : A Body : porcelain Glaze : white Decoration : Size (cm) : Unearthed From : Collected By : Guan Baocong collection Date (AD) : Published by: unpublished</p>	 <p>Cat. 1268</p>
<p>Catalogue No. : Cat. 1269 Type : A Body : porcelain Glaze : white Decoration : Carved multi-petalled flowers design Size (cm) : Height: 6.9; Diameter 9. Unearthed From : Collected By : Royal Ontario Museum, Toronto Date (AD) : Published by: Mino Yutaka et al. 1973, pl. 51.</p>	 <p>Cat. 1269</p>
<p>Catalogue No. : Cat. 1270 Type : A Body : stoneware Glaze : white Decoration : Size (cm) : Height: 5. Unearthed From : KL5 Collected By : Date (AD) : late Published by: Zhelimumeng bowuguan et al. 1982, 35-46, fig.2:7.</p>	 <p>Cat. 1270</p>
<p>Catalogue No. : Cat. 1271 Type : A Body : stoneware Glaze : white Decoration : Brown iron pigment painted Size (cm) : Height: 5.8. Unearthed From : Collected By : Date (AD) : late Published by: Lu Jing 2003, pl. 3-676.</p>	 <p>Cat. 1271</p>

<p>Catalogue No. : Cat. 1272 Type : A Body : stoneware Glaze : white Decoration : Brown iron pigment painted Size (cm) : Height: 5. Unearthed From : GGT kiln site Collected By : Guan Baocong collection Date (AD) : late Published by: Lu Jing 2003, pl. 4-239.</p>	 <p>Cat. 1272</p>
<p>Catalogue No. : Cat. 1273 Type : Ba Body : Pinkish earthenware Glaze : yellow Decoration : Moulded floral designs Size (cm) : Overall height: 21.5; Diameter of mouth: 6.6-12.6; Diameter of base: 8.5- 14.7. Unearthed From : JFYZ Collected By : Chifeng municipal museum Date (AD) : late Published by: Xiang Chunsong 1979, 330-34, fig.3; Shanghai renmin meishu chubanshe 1986, pl. 148; Shen Hsueh-man 2006, pl. 112.</p>	 <p>Cat. 1273</p>
<p>Catalogue No. : Cat. 1274 Type : Ba Body : Pinkish earthenware Glaze : Three-colored Decoration : Moulded floral designs Size (cm) : Height (single): 6.4; Diameter of mouth: 8.7- 18.3. Unearthed From : Collected By : Guan Baocong collection Date (AD) : late Published by: Lu Jing 2003, pl. 4-440.</p>	 <p>Cat. 1274</p>
<p>Catalogue No. : Cat. 1275 Type : Ba Body : Pinkish earthenware Glaze : Three-colored Decoration : Moulded floral designs Size (cm) : Height: 6.8; Length: 18.4. Unearthed From : Collected By : Date (AD) : late Published by: Lu Jing 2003, pl. 3-678.</p>	 <p>Cat. 1275</p>

<p>Catalogue No. : Cat. 1276 Type : Ba Body : Pinkish earthenware Glaze : Three-colored Decoration : Moulded floral designs Size (cm) : Height (single): 6.5; Length: 16. Unearthed From : Collected By : Chifeng municipal museum Date (AD) : late Published by: Shanghai renmin meishu chubanshe 1986, pl. 124.</p>	 <p>Cat. 1276</p>
<p>Catalogue No. : Cat. 1277 Type : Bb Body : Pinkish earthenware Glaze : Three-colored Decoration : Moulded floral designs Size (cm) : Height (single): 4.2; Diameter of mouth: 15.2. Unearthed From : JFYZ Collected By : Inner Mongolia autonomous region museum Date (AD) : late Published by: Xiang Chunsong 1979, 330-34.</p>	 <p>Cat. 1277</p>
<p>Catalogue No. : Cat. 1278 Type : Bb Body : Pinkish earthenware Glaze : Three-colored Decoration : Moulded floral designs Size (cm) : Height: 4.6; Diameter of mouth: 18. Unearthed From : Collected By : Guan Baocong collection Date (AD) : late Published by: Lu Jing 2003, pl. 3-432.</p>	 <p>Cat. 1278</p>
<p>Catalogue No. : Cat. 1279 Type : Bc Body : Pinkish earthenware Glaze : yellow Decoration : Size (cm) : Overall height:17; Diameter: 13.5. Unearthed From : A tomb at Baitazi commune, Kazuo County, Liaoning province Collected By : Kazuo Museum, Liaoning Province Date (AD) : Published by: Shanghai renmin meishu chubanshe 1986, pl. 125.</p>	 <p>Cat. 1279</p>



3.26 LAMP AND INCENSE BURNER

<p>Catalogue No. : Cat. 1280 Type : A Body : Porcelain Glaze : white Decoration : Size (cm) : Height: 7.9; Diameter of mouth: 9.8; Diameter of base: 5.8. Unearthed From : WZM Collected By : Date (AD) : 1053 Published by: Beijingshi wenwu guanlichu 35-40.</p>	 <p>Cat. 1280</p>
<p>Catalogue No. : Cat. 1281 Type : A Body : Porcelain Glaze : brown Decoration : Size (cm) : ? Unearthed From : LQW kiln site Collected By : Date (AD) : Late Published by: Beijingshi wenwu yanjiusuo 2002, pl.4:5.</p>	 <p>Cat. 1281</p>
<p>Catalogue No. : Cat. 1282 Type : A Body : Stoneware Glaze : white Decoration : Size (cm) : Height: 7.9; Diameter of mouth: 9.8; Diameter of base: 5.8. Unearthed From : Collected By : Guan Baocong collection Date (AD) : late Published by: Lu Jing 2003, pl. 3-680.</p>	 <p>Cat. 1282</p>
<p>Catalogue No. : Cat. 1283 Type : A Body : Pinkish earthenware Glaze : yellow Decoration : Size (cm) : Height: 7.5 Unearthed From : Collected By : Provate collection Date (AD) : late Published by: Lu Jing 2003, pl. 3-681.</p>	 <p>Cat. 1283</p>

<p>Catalogue No. : Cat. 1284 Type : Ba Body : Porcelain Glaze : white Decoration : Applied designs in relief Size (cm) : ? Unearthed From : LQW kiln site Collected By : Date (AD) : late Published by: Beijingshi wenwu yanjiusuo 2002, 272, fig.93:5, pl.4:3.</p>	 <p>Cat. 1284</p>
<p>Catalogue No. : Cat. 1285 Type : Bb Body : Porcelain Glaze : white Decoration : Applied designs in relief Size (cm) : ? Unearthed From : LQW kiln site Collected By : Date (AD) : late Published by: Beijingshi wenwu yanjiusuo 2002, pl.4:4.</p>	 <p>Cat. 1285</p>
<p>Catalogue No. : Cat. 1286 Type : C Body : stoneware Glaze : black Decoration : In the form of a lion Size (cm) : Height: 12. Unearthed From : GGT kiln site Collected By : Guan Baocong collection Date (AD) : late Published by: unpublished</p>	 <p>Cat. 1286</p>
<p>Catalogue No. : Cat. 1287 Type : C Body : stoneware Glaze : black Decoration : In the form of a lion Size (cm) : Height: 13. Unearthed From : GGT kiln site Collected By : Guan Baocong collection Date (AD) : late Published by: unpublished</p>	 <p>Cat. 1287</p>

<p>Catalogue No. : Cat. 1288 Type : C Body : stoneware Glaze : black Decoration : In the form of a lion Size (cm) : Height: 12.5. Unearthed From : GGT kiln site Collected By : Guan Baocong collection Date (AD) : late Published by: unpublished</p>	 <p>Cat. 1288</p>
<p>Catalogue No. : Cat. 1289 Type : C Body : stoneware Glaze : black Decoration : In the form of a lion Size (cm) : Height: 14. Unearthed From : GGT kiln site Collected By : Guan Baocong collection Date (AD) : late Published by: unpublished</p>	 <p>Cat. 1289</p>

3.27 SCULPTURE

<p>Catalogue No. : Cat. 1290 Type : Body : Stoneware Glaze : white Decoration : Black pigment painted deer. Size (cm) : Height: 6. Unearthed From : Collected By : Guan Baocong collection Date (AD) : Late Published by: Lu Jing 2003, pl. 2-136.</p>	 <p>Cat. 1290</p>
<p>Catalogue No. : Cat. 1291 Type : Body : Pinkish earthenware Glaze : green Decoration : Riding figure Size (cm) : Height: 6. Unearthed From : Hancheng site of Liaoshangjing site, Balin Left Banner, Inner Mongolia Collected By : Liaoshangjing Museum, Inner Mongolia Date (AD) : Late Published by: Tang Cailan 2005, pl. 80.</p>	 <p>Cat. 1291</p>



<p>Catalogue No. : Cat. 1292 Type : Body : Stoneware Glaze : white Decoration : Lion figure Size (cm) : Height: 3.5. Unearthed From : Hancheng site of Liaoshangjing site, Balin Left Banner, Inner Mongolia Collected By : Liaoshangjing Museum, Inner Mongolia Date (AD) : Late Published by: Tang Cailan 2005, pl. 80.</p>	 <p>Cat. 1292</p>
<p>Catalogue No. : Cat. 1293 Type : Body : Stoneware Glaze : White Decoration : Camel figure Size (cm) : Height: 5. Unearthed From : Hancheng site of Liaoshangjing site, Balin Left Banner, Inner Mongolia Collected By : Liaoshangjing Museum, Inner Mongolia Date (AD) : Late Published by: Tang Cailan 2005, pl. 80.</p>	 <p>Cat. 1293</p>
<p>Catalogue No. : Cat. 1294 Type : Body : Stoneware Glaze : Tee-dust green Decoration : Camel figure Size (cm) : Height: 6.2. Unearthed From : HDYG kiln site Collected By : Guan Baocong collection Date (AD) : Late Published by: Lu Jing 2003, pl. 3-692.</p>	 <p>Cat. 1294</p>
<p>Catalogue No. : Cat. 1295 Type : Body : Stoneware Glaze : white Decoration : Riding lion figure Size (cm) : Height: 14.5; Length: 9; Width: 4. Unearthed From : Lamagou village, Saliba Township, Aohan Banner, Inner Mongolia Collected By : Aohan Banner Museum, Inner Mongolia Date (AD) : Late Published by: Shao Guotian ed. 2004, pl. 154.</p>	 <p>Cat. 1295</p>

<p>Catalogue No. : Cat. 1296 Type : Body : Stoneware Glaze : white Decoration : Monkey figure Size (cm) : Height: 4.1. Unearthed From : Collected By : Aohan Banner Museum, Inner Mongolia Date (AD) : Late Published by: Shao Guotian ed. 2004, pl. 154.</p>	 <p>Cat. 1296</p>
<p>Catalogue No. : Cat. 1297 Type : Body : Stoneware Glaze : brown Decoration : Riding horse figure Size (cm) : Height: 5.5. Unearthed From : GGT kiln site Collected By : Guan Baocong collection Date (AD) : Late Published by: Lu Jing 2003, pl. 3-691.</p>	 <p>Cat. 1297</p>
<p>Catalogue No. : Cat. 1298 Type : Body : Porcelain Glaze : white Decoration : Sheep figure Size (cm) : Height: 8. Unearthed From : Collected By : Guan Baocong collection Date (AD) : Late Published by: Lu Jing 2003, pl. 3-684.</p>	 <p>Cat. 1298</p>
<p>Catalogue No. : Cat. 1299 Type : Body : Stoneware Glaze : white Decoration : Riding horse figure with black dotted Size (cm) : Height: 4.7. Unearthed From : Collected By : Guan Baocong collection Date (AD) : Late Published by: Lu Jing 2003, pl. 2-139.</p>	 <p>Cat. 1299</p>

<p>Catalogue No. : Cat. 1300 Type : Body : Stoneware Glaze : brown Decoration : Riding horse figure Size (cm) : Height: 7. Unearthed From : GGT kiln site Collected By : Guan Baocong collection Date (AD) : Late Published by: Unpublished</p>	 <p>Cat. 1300</p>
<p>Catalogue No. : Cat. 1301 Type : Body : Stoneware Glaze : Green and yellow Decoration : Riding horse figure Size (cm) : Height: 5.3. Unearthed From : GWYC kiln site Collected By : Guan Baocong collection Date (AD) : Late Published by: Lu Jing 2003, pl. 3-688.</p>	 <p>Cat. 1301</p>
<p>Catalogue No. : Cat. 1302 Type : Body : Stoneware Glaze : white Decoration : Riding horse figure with black dotted Size (cm) : Height: 4.2.. Unearthed From : GGT kiln site Collected By : Guan Baocong collection Date (AD) : Late Published by: Lu Jing 2003, pl. 3-690.</p>	 <p>Cat. 1302</p>
<p>Catalogue No. : Cat. 1303 Type : Body : Stoneware Glaze : black Decoration : Riding horse figure Size (cm) : Height: 4.5. Unearthed From : GGT kiln site Collected By : Guan Baocong collection Date (AD) : Late Published by: Lu Jing 2003, pl. 4-232 left.</p>	 <p>Cat. 1303</p>
<p>Catalogue No. : Cat. 1304 Type : Body : Stoneware Glaze : black Decoration : Riding horse figure Size (cm) : Height: 4. Unearthed From : GGT kiln site Collected By : Guan Baocong collection Date (AD) : Late Published by: Lu Jing 2003, pl. 4-232 right.</p>	 <p>Cat. 1304</p>

<p>Catalogue No. : Cat. 1305 Type : Body : Stoneware Glaze : white Decoration : Riding horse figure Size (cm) : Height: 4.5. Unearthed From : GWYC kiln site Collected By : Guan Baocong collection Date (AD) : Late Published by: Lu Jing 2003, pl. 3-685 right.</p>	 <p>Cat. 1305</p>
<p>Catalogue No. : Cat. 1306 Type : Body : Stoneware Glaze : brown Decoration : Riding horse figure Size (cm) : Height: 4.1. Unearthed From : GGT kiln site Collected By : Guan Baocong collection Date (AD) : Late Published by: Lu Jing 2003, pl. 3-689.</p>	 <p>Cat. 1306</p>
<p>Catalogue No. : Cat. 1307 Type : Body : Stoneware Glaze : white Decoration : Riding horse figure Size (cm) : Height: 4.3. Unearthed From : GWYC kiln site Collected By : Guan Baocong collection Date (AD) : Late Published by: Lu Jing 2003, pl. 3-685 middle.</p>	 <p>Cat. 1307</p>
<p>Catalogue No. : Cat. 1308 Type : Body : Stoneware Glaze : white Decoration : Riding horse figure Size (cm) : Height: 4.4. Unearthed From : GWYC kiln site Collected By : Guan Baocong collection Date (AD) : Late Published by: Lu Jing 2003, pl. 3-685 left.</p>	 <p>Cat. 1308</p>
<p>Catalogue No. : Cat. 1309 Type : Body : Stoneware Glaze : white Decoration : Riding horse figure Size (cm) : Height: 4.5. Unearthed From : GWYC kiln site Collected By : Guan Baocong collection Date (AD) : Late Published by: Lu Jing 2003, pl. 3-685 left.</p>	 <p>Cat. 1309</p>

<p>Catalogue No. : Cat. 1310 Type : Body : Stoneware Glaze : white Decoration : Riding horse figure Size (cm) : Height: 4.5. Unearthed From : GWYC kiln site Collected By : Guan Baocong collection Date (AD) : Late Published by: Lu Jing 2003, pl. 3-686 right.</p>	 <p>Cat. 1310</p>
<p>Catalogue No. : Cat. 1311 Type : Body : Stoneware Glaze : white Decoration : Riding horse figures Size (cm) : Height: 3.5-4.5. Unearthed From : GGT kiln site Collected By : Guan Baocong collection Date (AD) : Late Published by: Lu Jing 2003, pl. 3-687.</p>	 <p>Cat. 1311</p>
<p>Catalogue No. : Cat. 1312 Type : Body : Stoneware Glaze : white Decoration : Child figure Size (cm) : Height: 4. Unearthed From : GWYC kiln site Collected By : Guan Baocong collection Date (AD) : Late Published by: Lu Jing 2003, pl. 3-684.</p>	 <p>Cat. 1312</p>
<p>Catalogue No. : Cat. 1313 Type : Body : Stoneware Glaze : white Decoration : Child figure Size (cm) : Height: 4.5. Unearthed From : GWYC kiln site Collected By : Guan Baocong collection Date (AD) : Late Published by: Lu Jing 2003, pl. 3-683 middle.</p>	 <p>Cat. 1313</p>



<p>Catalogue No. : Cat. 1314 Type : Body : Stoneware Glaze : white Decoration : Child figure Size (cm) : Height: 5. Unearthed From : GWYC kiln site Collected By : Guan Baocong collection Date (AD) : Late Published by: Lu Jing 2003, pl. 3-683 right.</p>	 <p>Cat. 1314</p>
<p>Catalogue No. : Cat. 1315 Type : Body : Stoneware Glaze : white Decoration : Black pigment painted Size (cm) : Height: 6. Unearthed From : Collected By : Guan Baocong collection Date (AD) : Late Published by: Lu Jing 2003, pl. 2-136.</p>	 <p>Cat. 1315</p>
<p>Catalogue No. : Cat. 1316 Type : Body : Stoneware Glaze : white Decoration : Black pigment painted Size (cm) : Height: 6. Unearthed From : Hancheng site of Liaoshangjing site, Balin Left Banner, Inner Mongolia Collected By : Liaoshangjing Museum, Inner Mongolia Date (AD) : Late Published by: Tang Cailan 2005, pl. 80.</p>	 <p>Cat. 1316</p>
<p>Catalogue No. : Cat. 1317 Type : Body : Stoneware Glaze : white Decoration : Black pigment painted Size (cm) : Height: 5.5. Unearthed From : Hancheng site of Liaoshangjing site, Balin Left Banner, Inner Mongolia Collected By : Liaoshangjing Museum, Inner Mongolia Date (AD) : Late Published by: Tang Cailan 2005, pl. 80.</p>	 <p>Cat. 1317</p>

<p>Catalogue No. : Cat. 1318 Type : Body : Stoneware Glaze : white Decoration : Child figure Size (cm) : Height: 7. Unearthed From : Hancheng site of Liaoshangjing site, Balin Left Banner, Inner Mongolia Collected By : Liaoshangjing Museum, Inner Mongolia Date (AD) : Late Published by: Tang Cailan 2005, pl. 80.</p>	 <p>Cat. 1318</p>
<p>Catalogue No. : Cat. 1319 Type : Body : Stoneware Glaze : white Decoration : Child figure Size (cm) : Height: 7. Unearthed From : Hancheng site of Liaoshangjing site, Balin Left Banner, Inner Mongolia Collected By : Liaoshangjing Museum, Inner Mongolia Date (AD) : Late Published by: Tang Cailan 2005, pl. 80.</p>	 <p>Cat. 1319</p>
<p>Catalogue No. : Cat. 1320 Type : Body : Porcelain Glaze : white Decoration : Qidan figure Size (cm) : Height: 7. Unearthed From : Collected By : Guan Baocong collection Date (AD) : Late Published by: Lu Jing 2003, pl. 4-338.</p>	 <p>Cat. 1320</p>
<p>Catalogue No. : Cat. 1321 Type : Body : Stoneware Glaze : blackk Decoration : Size (cm) : Height: 7.2. Unearthed From : GGT kiln site Collected By : Guan Baocong collection Date (AD) : Late Published by: Lu Jing 2003, pl. 3-691.</p>	 <p>Cat. 1321</p>

<p>Catalogue No. : Cat. 1322 Type : Body : Pinkish earthenware Glaze : Three-colored Decoration : Qidan child figure Size (cm) : Height: 7. Unearthed From : Collected By : Date (AD) : Late Published by: Lu Jing 2003, pl. 4-362.</p>	 <p>Cat. 1322</p>
<p>Catalogue No. : Cat. 1323 Type : Body : Pinkish earthenware Glaze : Three-colored Decoration : mortuary models Size (cm) : Unearthed From : Collected By : Capital Museum, Beijing Date (AD) : Late Published by: Lu Jing 2003 pl. 4-209-1.</p>	 <p>Cat. 1323</p>
<p>Catalogue No. : Cat. 1324 Type : Body : Pinkish earthenware Glaze : Three-colored Decoration : mortuary models Size (cm) : Height: 2.2-3.7. Unearthed From : Collected By : Capital Museum, Beijing Date (AD) : Late Published by: Lu Jing 2003 pl. 4-209-7, 4.</p>	 <p>Cat. 1324</p>
<p>Catalogue No. : Cat. 1325 Type : Body : Pinkish earthenware Glaze : Three-colored Decoration : mortuary models Size (cm) : Height: 3.4. Unearthed From : Collected By : Capital Museum, Beijing Date (AD) : Late Published by: Lu Jing 2003 pl. 4-209-6.</p>	 <p>Cat. 1325</p>
<p>Catalogue No. : Cat. 1326 Type : Body : Pinkish earthenware Glaze : Three-colored Decoration : mortuary models Size (cm) : Height: 3.2. Unearthed From : Collected By : Capital Museum, Beijing Date (AD) : Late Published by: Lu Jing 2003 pl. 4-209-10.</p>	 <p>Cat. 1326</p>

<p>Catalogue No. : Cat. 1327 Type : Body : Pinkish earthenware Glaze : Three-colored Decoration : mortuary models Size (cm) : Height: 3.6. Unearthed From : Collected By : Capital Museum, Beijing Date (AD) : Late Published by: Lu Jing 2003 pl. 4-209-13.</p>	 <p>Cat. 1327</p>
<p>Catalogue No. : Cat. 1328 Type : Body : Pinkish earthenware Glaze : Three-colored Decoration : mortuary models Size (cm) : Height: 2.2. Unearthed From : Collected By : Capital Museum, Beijing Date (AD) : Late Published by: Lu Jing 2003 pl. 4-209-5.</p>	 <p>Cat. 1328</p>
<p>Catalogue No. : Cat. 1329 Type : Body : Pinkish earthenware Glaze : Three-colored Decoration : mortuary models Size (cm) : Height: 2.7. Unearthed From : Collected By : Capital Museum, Beijing Date (AD) : Late Published by: Lu Jing 2003 pl. 4-209-14.</p>	 <p>Cat. 1329</p>
<p>Catalogue No. : Cat. 1330 Type : Body : Pinkish earthenware Glaze : Three-colored Decoration : mortuary models Size (cm) : Height: 3. Unearthed From : Collected By : Capital Museum, Beijing Date (AD) : Late Published by: Lu Jing 2003 pl. 4-209-11.</p>	 <p>Cat. 1330</p>
<p>Catalogue No. : Cat. 1331 Type : Body : Pinkish earthenware Glaze : Three-colored Decoration : mortuary models Size (cm) : Height: 4.7. Unearthed From : Collected By : Capital Museum, Beijing Date (AD) : Late Published by: Lu Jing 2003 pl. 4-209-8.</p>	 <p>Cat. 1331</p>

<p>Catalogue No. : Cat. 1332 Type : Body : Pinkish earthenware Glaze : Three-colored Decoration : mortuary models Size (cm) : Height: 3. Unearthed From : Collected By : Capital Museum, Beijing Date (AD) : Late Published by: Lu Jing 2003 pl. 4-209-12.</p>	 <p>Cat. 1332</p>
<p>Catalogue No. : Cat. 1333 Type : Body : Pinkish earthenware Glaze : Three-colored Decoration : mortuary models Size (cm) : Height: 4.5. Unearthed From : Collected By : Capital Museum, Beijing Date (AD) : Late Published by: Lu Jing 2003 pl. 4-209-9.</p>	 <p>Cat. 1333</p>
<p>Catalogue No. : Cat. 1334 Type : Body : Pinkish earthenware Glaze : Three-colored Decoration : mortuary models Size (cm) : Height: 7.5-7.7. Unearthed From : Collected By : Capital Museum, Beijing Date (AD) : Late Published by: Lu Jing 2003 pl. 4-209-2.</p>	 <p>Cat. 1334</p>
<p>Catalogue No. : Cat. 1335 Type : Body : Pinkish earthenware Glaze : Three-colored Decoration : Mortuare bed Size (cm) : Height: 7.8; Length: 15.4; Width: 7.8. Unearthed From : Collected By : Liaoning Provincial Museum Date (AD) : Late Published by: Zhongguo taoci quanji bianji weiyuanhui 1999, pl. 101; Shoudu bowuguan 1991, pl. 165; Shanghai renmin meishu chubanshe 1986, pl. 111; Liaoningsheng bowuguan 1961, pl. 12.</p>	 <p>Cat. 1335</p>

<p>Catalogue No. : Cat. 1336 Type : Body : Porcelain Glaze : white Decoration : Mortuate pagoda Size (cm) : ? Unearthed From : The foundation of Pagoda Qiyinsi, Xianghe, Hebei province Collected By : Date (AD) : 1006 Published by: Zhang Zhaoxiang 1989, 137.</p>	 <p>Cat. 1336</p>
<p>Catalogue No. : Cat. 1337 Type : Body : Porcelain Glaze : White Decoration : Ananda figure Size (cm) : Height: 27. Unearthed From : Qianwulibuge village, Nailingaosumu, Kulun Banner, Inner Mongolia Collected By : Tongliao Municipal Museum, Inner Mongolia Date (AD) : Published by: Shanghai bowuguan 2000, pl. 177; Shen Hsueh-man 2006, 68a.</p>	 <p>Cat. 1337</p>
<p>Catalogue No. : Cat. 1338 Type : Body : Porcelain Glaze : White Decoration : Kasyapa figure Size (cm) : Height: 26.5. Unearthed From : Qianwulibuge village, Nailingaosumu, Kulun Banner, Inner Mongolia Collected By : Tongliao Municipal Museum, Inner Mongolia Date (AD) : Published by: Shanghai bowuguan 2000, pl. 176; Shen Hsueh-man 2006, 68b.</p>	 <p>Cat. 1338</p>
<p>Catalogue No. : Cat. 1339 Type : Body : Pinkish earthenware Glaze : Three-colored Decoration : Kasyapa figure Size (cm) : Unearthed From : Yizhou, Hebei province Collected By : Date (AD) : Late Published by: Lu Jing 2003, pl. 2-166.</p>	 <p>Cat. 1339</p>

<p>Catalogue No. : Cat. 1340 Type : Body : Pinkish earthenware Glaze : Three-colored Decoration : Ananda figure Size (cm) : Unearthed From : Yizhou, Hebei Province Collected By : Date (AD) : Late Published by: Lu Jing 2003, pl. 2-165.</p>	 <p>Cat. 1340</p>
<p>Catalogue No. : Cat. 1341 Type : Body : Pinkish earthenware Glaze : Three-colored Decoration : Ananda figure Size (cm) : Height: 101.1. Unearthed From : Collected By : Kansas Museum Date (AD) : Late Published by: Lu Jing 2003, pl. 2-163.</p>	 <p>Cat. 1341</p>
<p>Catalogue No. : Cat. 1342 Type : Body : Pinkish earthen ware biscuit Glaze : Decoration : Pusa figure Size (cm) : Unearthed From : LQW kiln site Collected By : Date (AD) : Late Published by: Beijingshi wenwu yanjiusuo 2002, pl.6.</p>	 <p>Cat. 1342</p>
<p>Catalogue No. : Cat. 1343 Type : Body : Pinkish earthenware Glaze : Three-colored Decoration : Pusa figure Size (cm) : Unearthed From : LQW kiln site Collected By : Capital Museum, Beijing Date (AD) : Late Published by: Beijingshi wenwu yanjiusuo 2002, pl.7.</p>	 <p>Cat. 1343</p>

<p>Catalogue No. : Cat. 1344 Type : Body : Stoneware Glaze : black Decoration : Buddha figure Size (cm) : Height: 12.8 Unearthed From : GGT kiln site Collected By : Guan Baocong collection Date (AD) : Late Published by: Lu Jing 2003, pl. 2-147.</p>	 <p>Cat. 1344</p>
<p>Catalogue No. : Cat. 1345 Type : Body : Pinkish earthenware Glaze : Three-colored Decoration : Size (cm) : Height: 9.6; Length: 16.5; Width: 6.1. Unearthed From : Collected By : Guan Baocong collection Date (AD) : Late Published by: Lu Jing 2003, pl. 4-195.</p>	 <p>Cat. 1345</p>

PLATES AND FIGURES



Pl. 1: GWYC kiln-landscape



Pl. 2: Liao-type tile with molded animal mask



Pl. 3: GWYC-white stoneware



Pl. 4: GWYC-white stoneware



Pl. 5: GWYC-White porcelain



Pl. 6: GWYC-lead glazed earthenware



Pl. 7: GWYC-lead glazed earthenware



Pl. 8: GWYC- black (brown, tea-dust green glazed stoneware



Pl. 9: GWYC- black (brown glazed stoneware)



Pl. 10: GWYC- sgraffito black painted white stoneware



Pl. 11: GWYC- black painted white stoneware



Pl. 12: GWYC-sgraffito white stoneware



Pl. 13: GWYC- white stoneware with carved-lines decoration

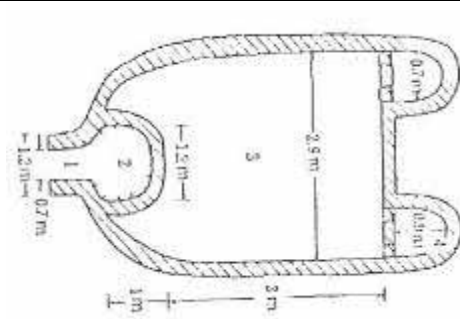

Fig. 1: GWYC-kiln (Mok 1985, fig.13)

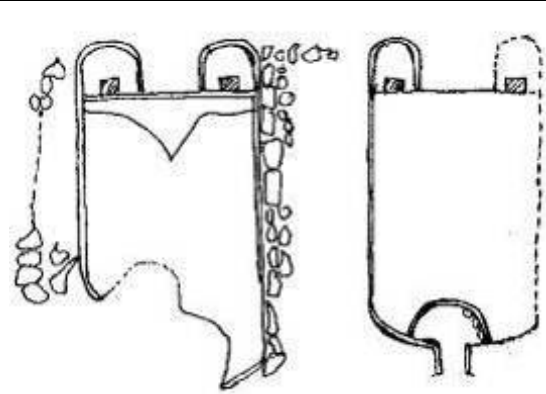

Fig. 2: GWYC-kilns (Peng Shanguo 2003,35, fig.2-1)

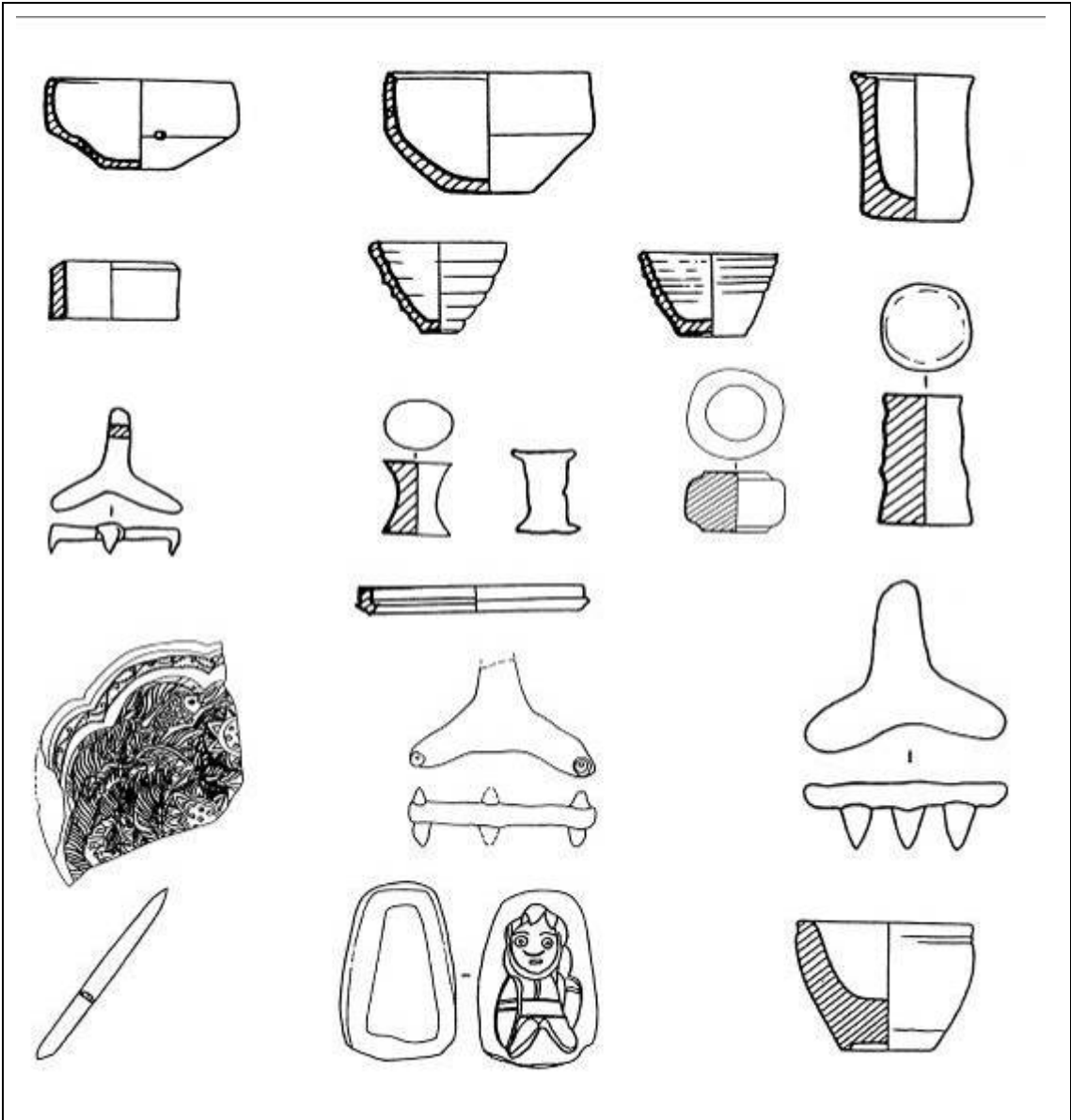

Fig. 3: GWYC- kiln instruments (after Peng Shanguo 2003, 36-36, fig. 2-2, 2-3, changed)



Pl. 14: GWYC- kiln instruments



Pl. 15: GWYC- kiln instruments



Pl. 16: GWYC- kiln instruments



Pl. 17: GWYC- kiln instruments



Pl. 18: GWYC-Stacked white bowls with support-spurs left on the bottom



Pl. 19: GWYC- white bowl with spur-scars left on the bottom



Pl. 20: GWYC- Sticked white bowls' stacks



Pl. 21: GWYC- circle-shaped instruments



Pl. 22: GWYC-triangular shaped spurs

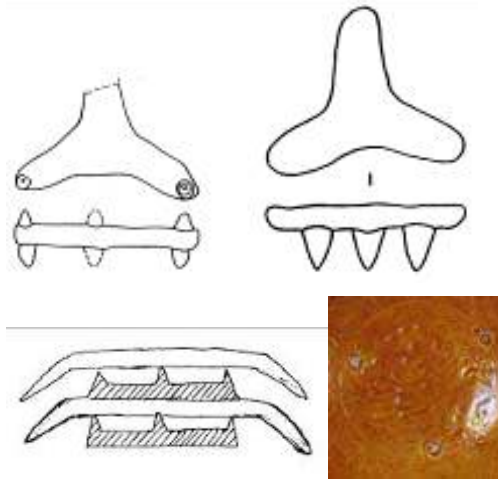

Fig. 4: GWYC-triangular shaped spurs and the loading method

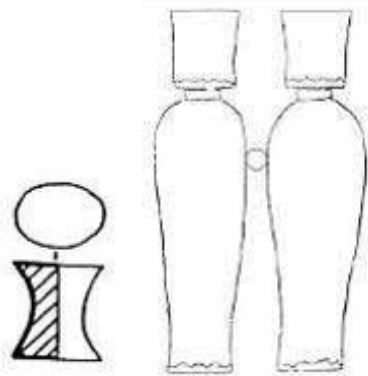

Fig. 5: GWYC- bobbin shaped supporting instrument and usage



Pl. 23: GWYC-cylinder shaped supporting instruments



Pl. 24: GWYC-bowl



Pl. 25: : GWYC-ocarina



Pl. 26: GWYC-chessmen



Pl. 27: GWYC-vase



Pl. 28: GWYC-ewer



Pl. 29: GWYC-ewer



Pl. 30: GWYC-inkstone



Pl. 31: GWYC-dish



Pl. 32: GWYC-jar



Pl. 33: GWYC- vase



Pl. 34: GWYC-ewer



Pl. 35: GWYC—chicken leg vase



Pl. 36: GWYC-inkstone & brush-wash basin



Pl. 37: GWYC-incense burner & box



Pl. 38: GWYC- jar, vase & bowls



Pl. 39: GWYC-bowls



Pl. 40: GWYC-dishes & bag-shaped pilgrim flask



Pl. 41: GWYC- jar



Pl. 42: GWYC: outer-mold of ewer



Pl. 43: GWYC- inner-mold of dish



Fig. 6: GWYC- decorations (Jia Zhoujie 1973, 241-3,fig.2)

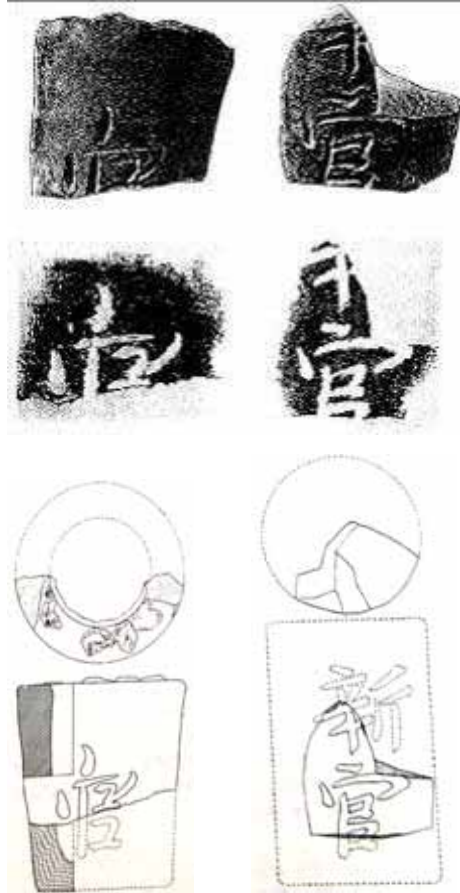

Pl. 44: GWYC- Guan and Xinguan mark on cylinder shaped firing instruments (Feng Yongqian 1984a, 386-92, pl.14:1,2, fig.2:1,3.)



Pl. 45: SJY- landscape



Pl. 46: SJY-excavation trenches in 1940 by Li Wenxin and Kuroda Genji

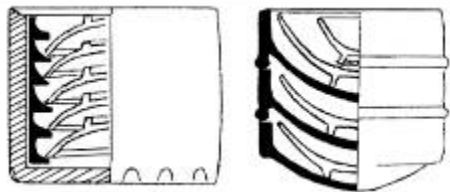

Fig. 7: SJY- saggars

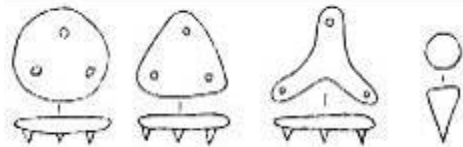

Fig. 8: SJY-supporting spurs



Pl. 47: SJY- saggar shards



Pl. 48: SJY- white porcelain shards



Pl. 49: SJY- white stoneware shards

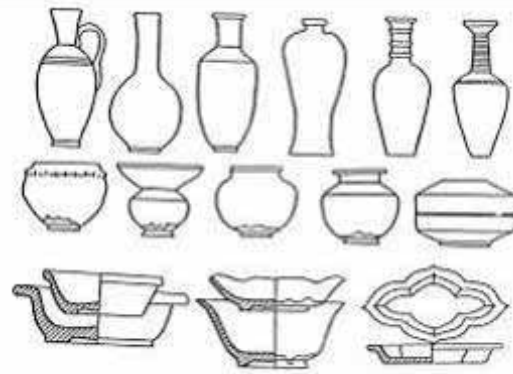

Fig. 9: SJY- vessel shapes



Pl. 50: SJY-white porcelain shard with incised designs



Pl. 51: SJY- black glazed stoneware



Pl. 52: SJY- black glazed big jar shard



Pl. 53: SJY tea-dust green glazed stoneware



Pl. 54: SJY- marbled ware



Pl. 55: BYGL-landscape



Pl. 56: BYGL-broken fire bricks with kiln sweat



Pl. 57: BYGL- cylinder shaped supporting instruments



Pl. 58: BYGL-shards spread around



Pl. 59: BYGL-bobbin shaped supporting instruments



Pl. 60: BYGL-shard of chicken-leg vase



Pl. 61: BYGL-black (tea-dust green) glazed stoneware



Pl. 62: BYGL-white stoneware



Pl. 63: HDYG-tea-dust green glazed camel



Pl. 64: GGT-landscape

: GGT-



Pl. 65: GGT- sticked bowls' stacks



Pl. 66: GGT-three spur-scars left on the dishes' bottoms



Pl. 67: GGT-unglazed circle and some with spur-scars left on the bowls' bottoms



Pl. 68: GGT- four spur-scars left on the bowls' bottoms



Pl. 69: GGT-supporting clay pads



Pl. 70: GGT- cylinder shaped support instruments



Pl. 71: GGT- mold instruments



Pl. 72: GGT-mold instrument



Pl. 73: GGT-mold instrument



Pl. 74: GGT- firing and loading instruments



Pl. 75: GGT- bobbin shaped spacers



Pl. 76: three-foot shaped spacers



Pl. 77: GGT- strip shaped instruments



Pl. 78: GGT-triangular spacer



Pl. 79: GGT-cone shaped instruments



Pl. 80: GGT- white glazed bowl



Pl. 81: GGT- white glazed bowl



Pl. 82: GGT- white glazed bowl



Pl. 83: GGT- white glazed bowl



Pl. 84: GGT- white glazed bowl



Pl. 85: GGT- white glazed bowl



Pl. 86: GGT- white glazed bowl



Pl. 87: GGT- white glazed bowl



Pl. 88: GGT- white glazed bowl



Pl. 89: GGT- white glazed bowl



Pl. 90: GGT- white glazed dish



Pl. 91: GGT- white glazed dish



Pl. 92: GGT- white glazed dish



Pl. 93: GGT- white glazed ewer



Pl. 94: GGT- white glazed ewer



Pl. 95: GGT- white glazed incense burner



Pl. 96: GGT- white glazed incense burner



Pl. 97: GGT- white glazed jar



Pl. 98: GGT- white glazed jar



Pl. 99: GGT- white glazed jar



Pl. 100: GGT- white glazed jar



Pl. 101: GGT- white glazed jar



Pl. 102: GGT- white glazed vase



Pl. 103: GGT- white glazed vase



Pl. 104: GGT- white glazed vase



Pl. 105: GGT- white glazed basin



Pl. 106: GGT- white glazed basin



Pl. 107: GGT- white glazed covers



Pl. 108: GGT- white glazed covers



Pl. 109: GGT- white glazed figures



Pl. 110: GGT- white glazed figures



Pl. 111: GGT- white and black glazed animal toys



Pl. 112: GGT- white glazed animal toys



Pl. 113: GGT- white glazed taming-lion toys



Pl. 114: GGT- white glazed toy



Pl. 115: GGT- white glazed inkstone



Pl. 116: GGT- white glazed mini vases



Pl. 117: GGT- black glazed bowl



Pl. 118: GGT- black glazed bowl



Pl. 119: GGT- black glazed bowl



Pl. 120: GGT- black glazed bowl



Pl. 121: GGT- black glazed bowl



Pl. 122: GGT- black glazed bowl



Pl. 123: GGT- black glazed bowl



Pl. 124: GGT- black glazed bowl



Pl. 125: GGT- black glazed bowl



Pl. 126: GGT- black glazed dish



Pl. 127: GGT- black glazed step-bowl



Pl. 128: GGT- black glazed mini vase



Pl. 129: GGT- black glazed vases



Pl. 130: GGT- black glazed vase



Pl. 131: GGT- black glazed vase



Pl. 132: GGT- black glazed vase



Pl. 133: GGT- black glazed vase



Pl. 134: GGT- black glazed vase



Pl. 135: GGT- black glazed vase



Pl. 136: GGT- black glazed chicken-leg vase



Pl. 137: GGT- black glazed vase



Pl. 138: GGT- black glazed ewer



Pl. 139: GGT- black glazed ewer



Pl. 140: GGT- black glazed ewer



Pl. 141: GGT- black glazed ewer



Pl. 142: GGT- black glazed ewer



Pl. 143: GGT- black glazed jar



Pl. 144: GGT- black glazed jar



Pl. 145: GGT- black glazed jar



Pl. 146: GGT- tea-dust green glazed jar



Pl. 147: GGT- black glazed jar



Pl. 148: GGT- black glazed saucer



Pl. 149: GGT- inner black glazed jar



Pl. 150: GGT- black glazed jar



Pl. 151: GGT- black glazed basin



Pl. 152: GGT- black glazed ewer



Pl. 153: GGT- black glazed covers



Pl. 154: GGT- black glazed cover



Pl. 155: GGT- black glazed lamp



Pl. 156: GGT- black glazed lamp



Pl. 157: GGT- black glazed lamp



Pl. 158: GGT- black glazed lamp



Pl. 159: GGT- black glazed lamp



Pl. 160: GGT- black glazed lamp



Pl. 161: GGT- black glazed dog-shape toy



Pl. 162: GGT- black glazed horse-shape toy



Pl. 163: GGT- black glazed toys



Pl. 164: GGT- black glazed monkey-shape toy



Pl. 165: GGT- black glazed animal-head shaped ocarinas



Pl. 166: GGT- black glazed animal-head shaped ocarinas



Pl. 167: GGT- black glazed animal-head shaped ocarinas



Pl. 168: GGT- black glazed animal-head shaped ocarina



Pl. 169: GGT- black glazed shard of ewer with inner tube



Pl. 170: GGT- black glazed animal mask



Pl. 171: GGT- unglazed chessmen



Pl. 172: LQW-landscape (Beijingshi wenwu yanjiusuo 2002, pl.1)

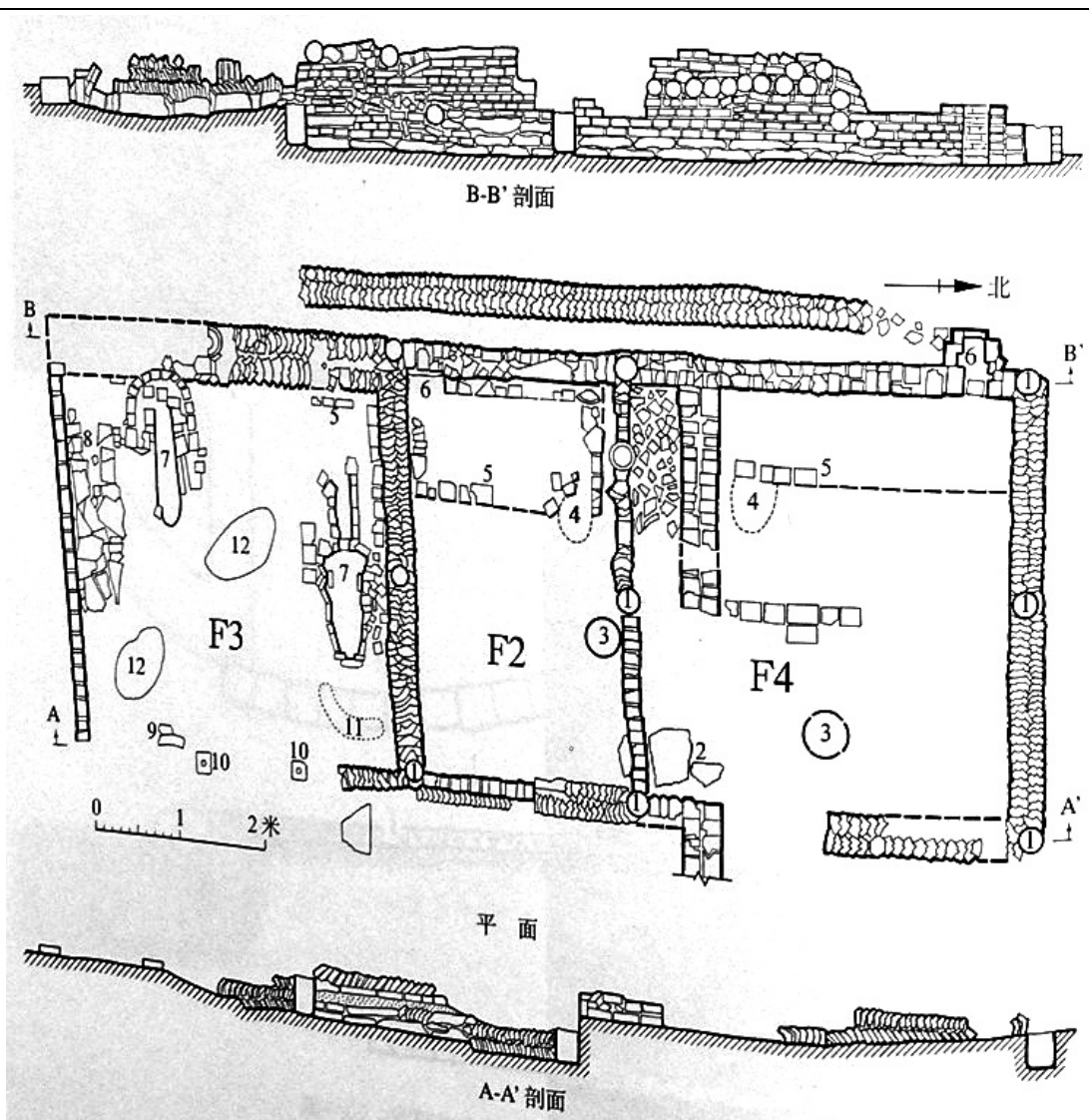

Fig. 10: LQW- workshop 2-4 (Beijingshi wenwu yanjiusuo 2002, 54, fig. 11)

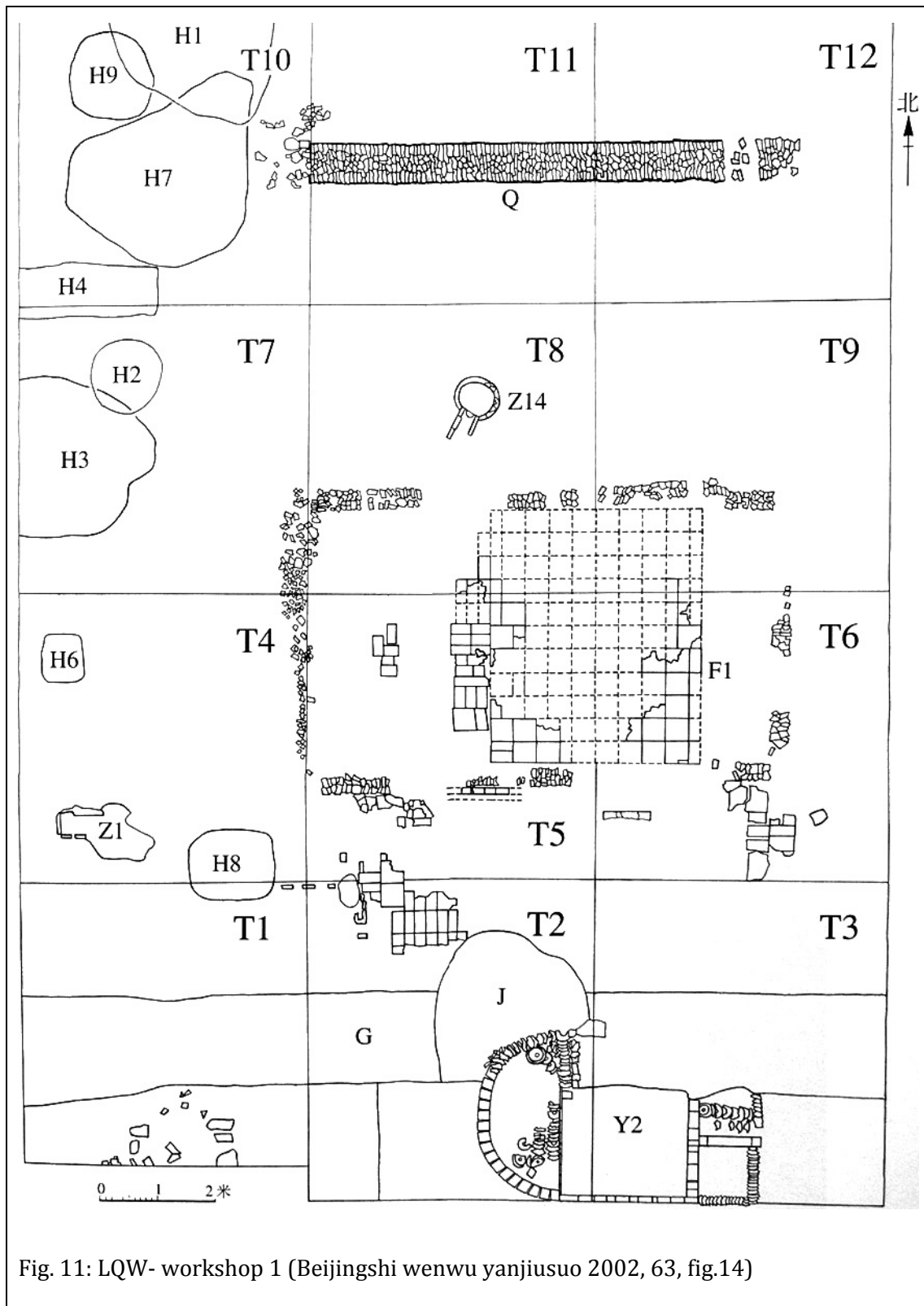

Fig. 11: LQW- workshop 1 (Beijingshi wenwu yanjiusuo 2002, 63, fig.14)

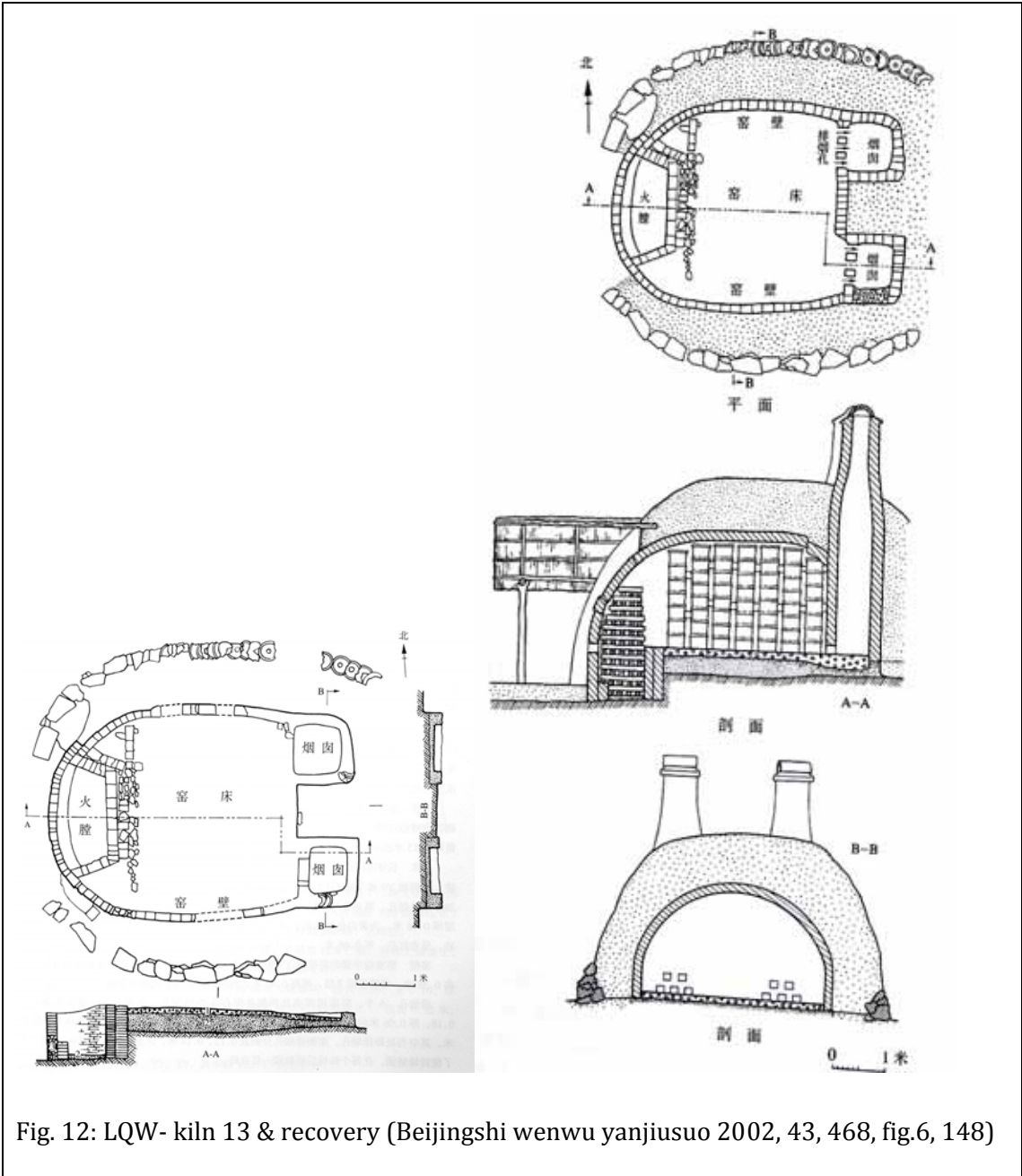

Fig. 12: LQW- kiln 13 & recovery (Beijingshi wenwu yanjiusuo 2002, 43, 468, fig.6, 148)

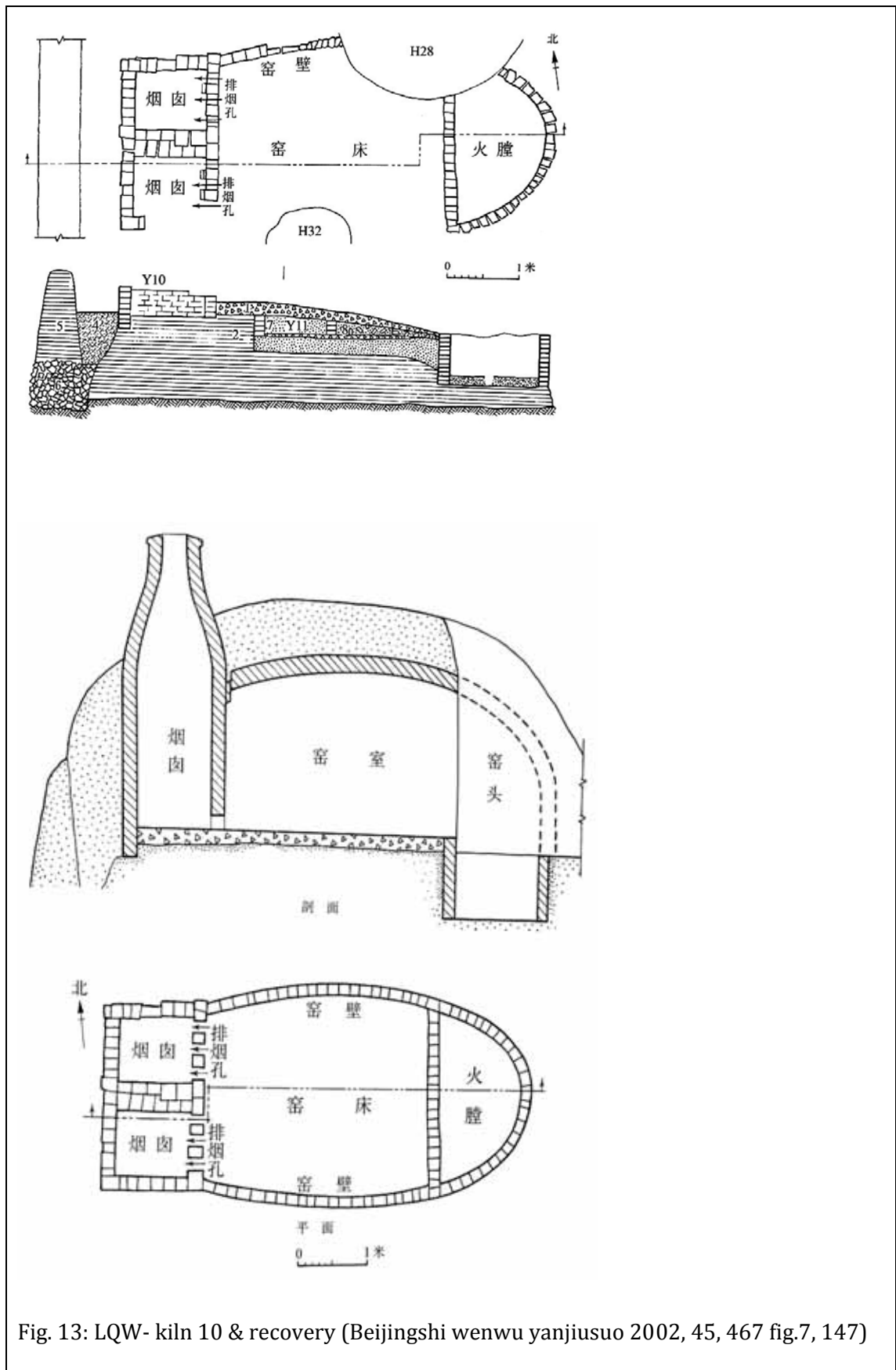

Fig. 13: LQW- kiln 10 & recovery (Beijingshi wenwu yanjiusuo 2002, 45, 467 fig.7, 147)

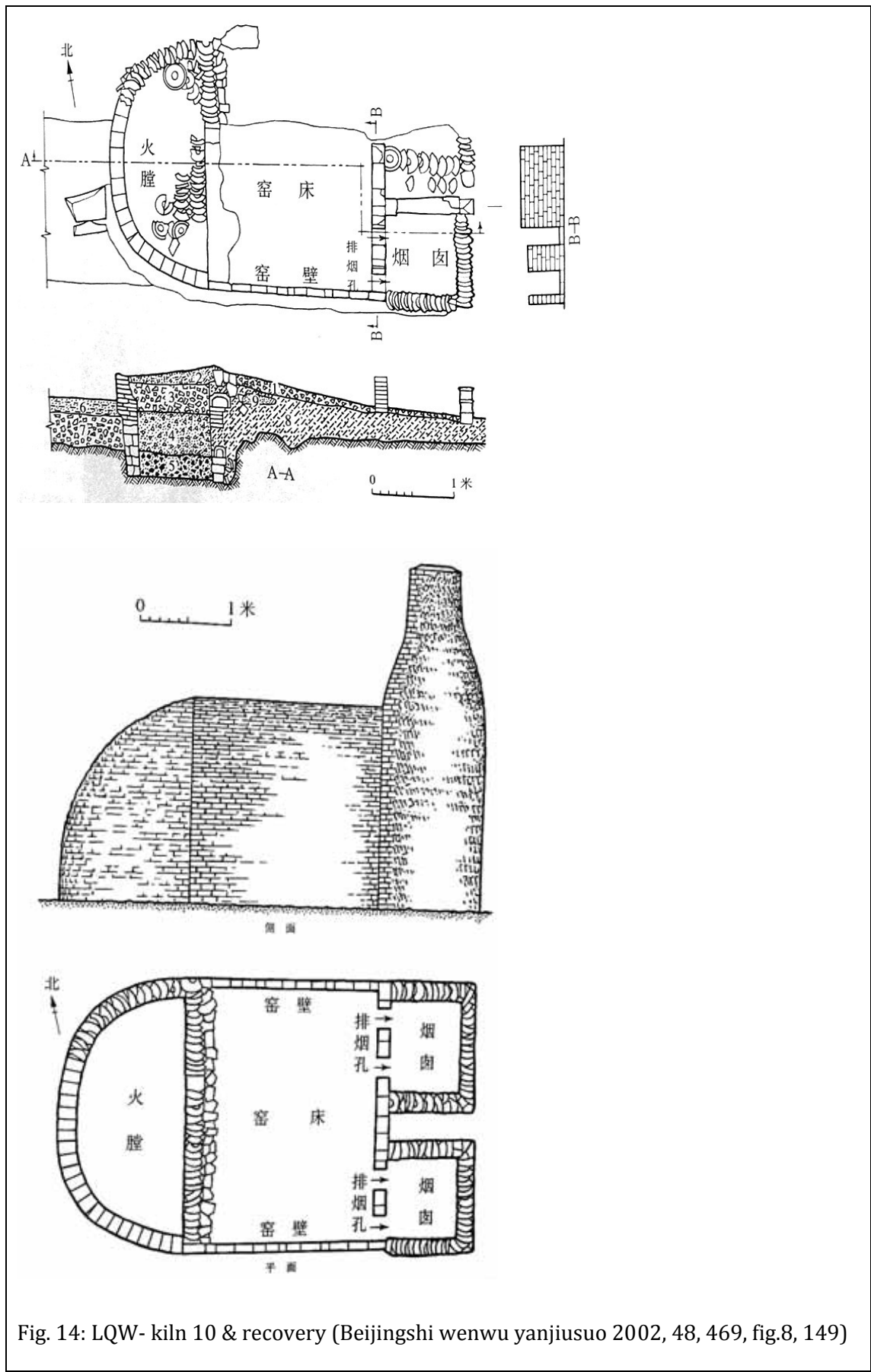

Fig. 14: LQW- kiln 10 & recovery (Beijingshi wenwu yanjiusuo 2002, 48, 469, fig.8, 149)

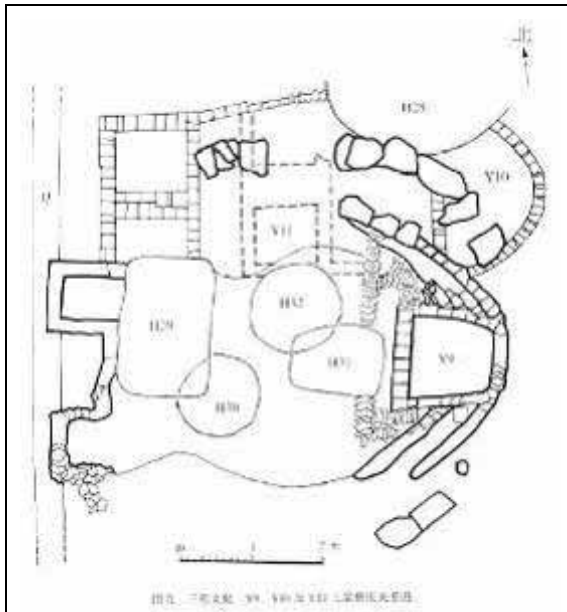

Fig. 15: LQW- kiln 9-11 (Beijingshi wenwu yanjiusuo 2002, 51, fig.9.)

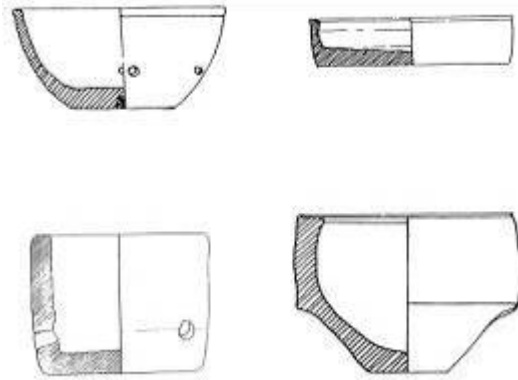

Fig. 16: LQW- saggars (Beijingshi wenwu yanjiusuo 2002, 112, 115, fig.33, fig.34, changed)

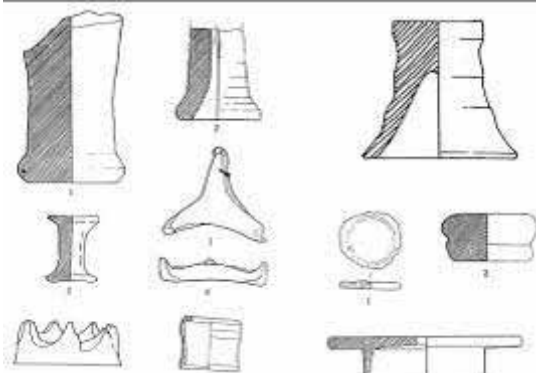

Fig. 17: LQW- firing instruments (Beijingshi wenwu yanjiusuo 2002, 117, fig.35, changed)

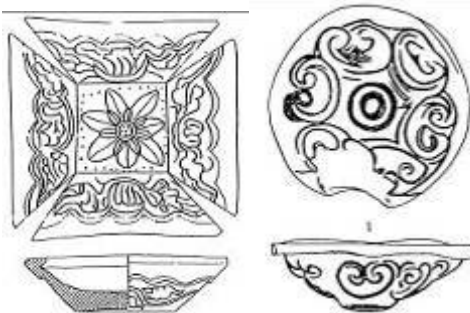

Fig. 18: LQW-inner molds of square dish and round dish (Beijingshi wenwu yanjiusuo 2002, 182, fig.59:1)

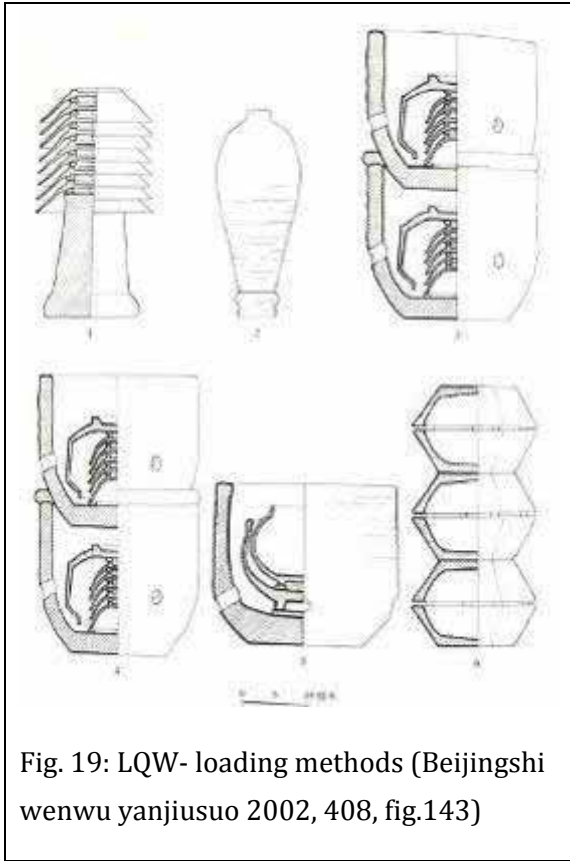

Fig. 19: LQW- loading methods (Beijingshi wenwu yanjiusuo 2002, 408, fig.143)

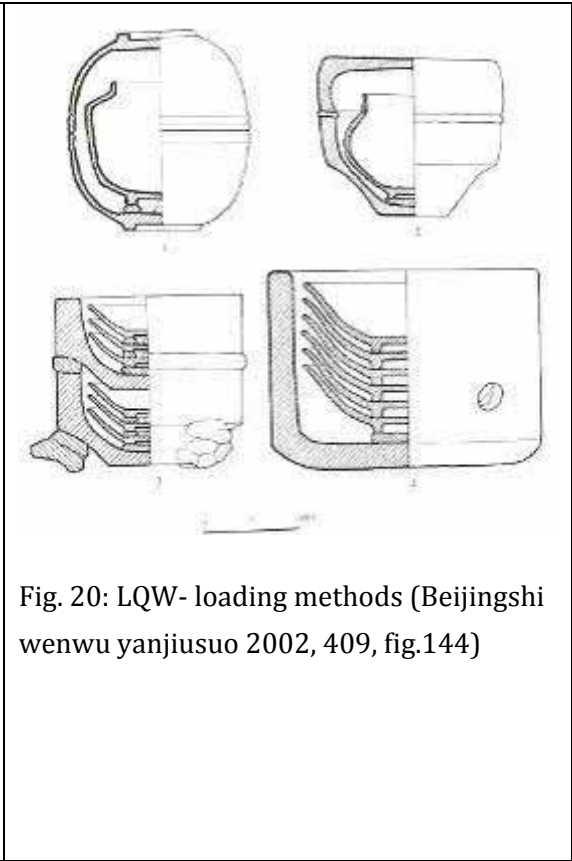

Fig. 20: LQW- loading methods (Beijingshi wenwu yanjiusuo 2002, 409, fig.144)

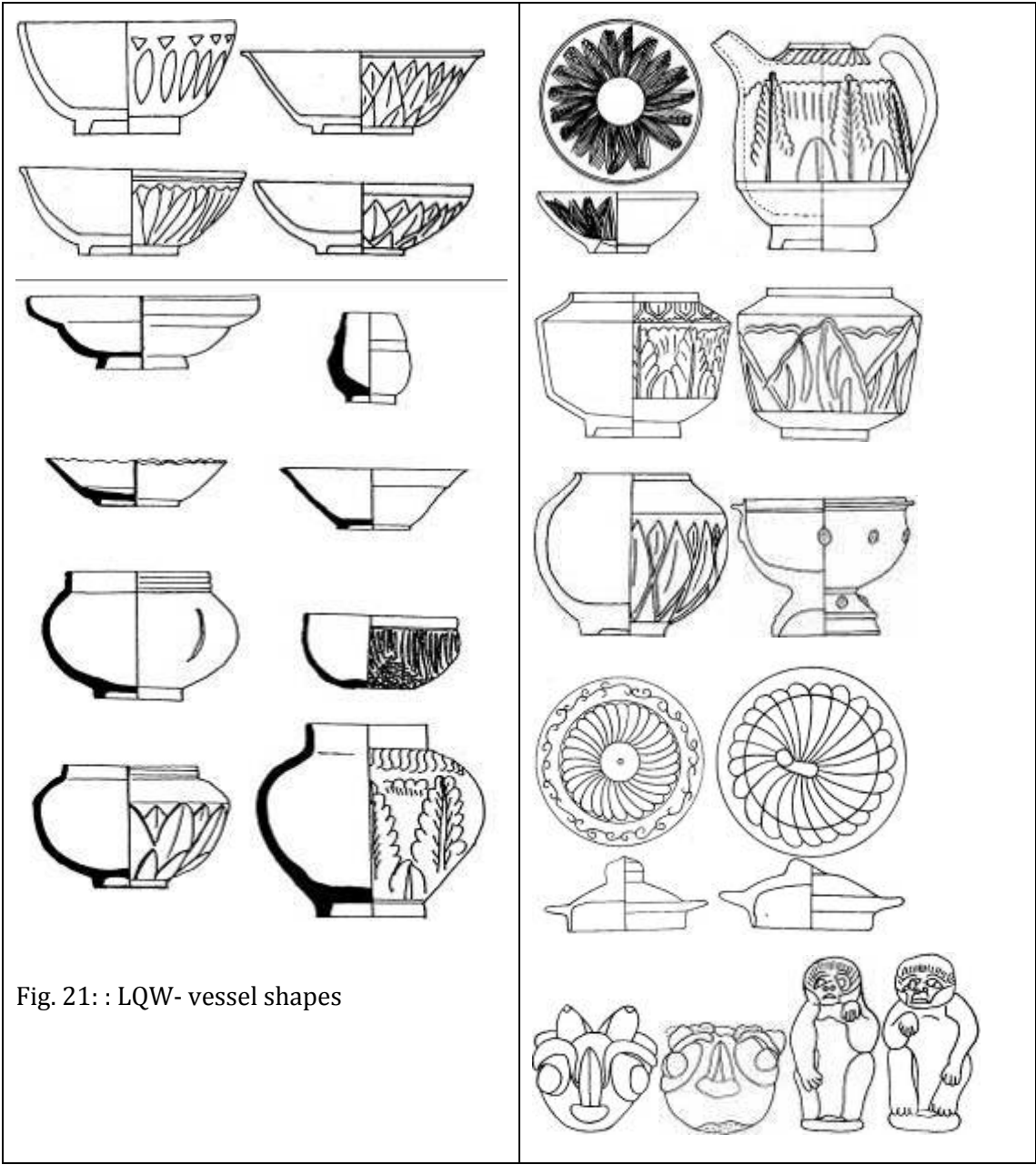

Fig. 21: : LQW- vessel shapes



Pl. 173: LQW- white stoneware shards



Pl. 174: LQW- white stonewares
(Beijingshi wenwu yanjiusuo 2002, pl.5)



Pl. 175: LQW- white porcelain shards



Pl. 176: LQW- white porcelain bowl



Pl. 177: LQW- white porcelain dish



Pl. 178: LQW- green and yellow glazed earthenwares (Beijingshi wenwu yanjiusuo 2002, pl.3)



Pl. 179: LQW- three color glazed earthenware buddha and unglazed buddha biscuit (Beijingshi wenwu yanjiusuo 2002, pl.6,7)



Pl. 180: LQW- three-color glazed tile with Shouchangwu inscription (Beijingshi wenwu yanjiusuo 2002, pl.8:1,2)



Pl. 181: XSY-firing instruments (Zhao guanglin 1984a, 410, fig.3)



Pl. 182: CJW-firing instruments (Zhao Guanglin 1984a, 412, fig.6)



Pl. 183: JZY- landscape

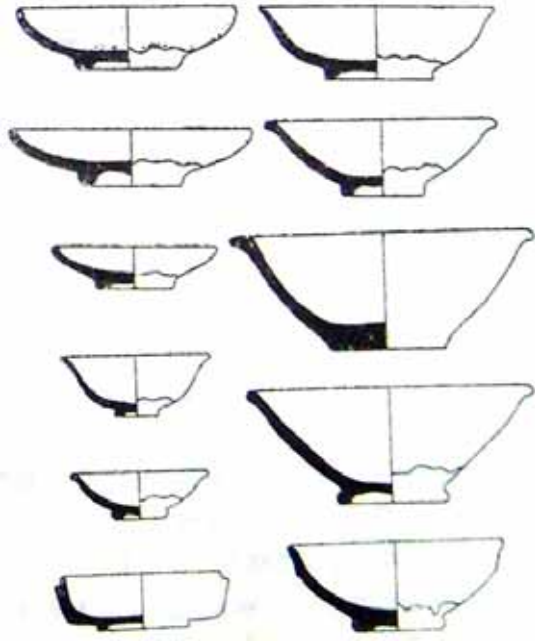

Fig. 22: JZY- vessel shapes (Feng Xianming 1984, 417, fig.3)



Pl. 184: JZY- white porcelain square dish



Pl. 185: JZY- white stoneware shards



Pl. 186: JZY- white porcelain spittoon



Pl. 187: JZY-brown glazed jar shard



Pl. 188: JZY- white stoneware bowl shard



Pl. 189: JZY- white stoneware jar



Pl. 190: JZY- brown glazed jar



Pl. 191: JZY- white glazed stoneware shard with carved design



Pl. 192: JZY- White stoneware shards



Pl. 193: JZY- white and black glazed shards

Pl. 194: JZY- white shards



Pl. 195: JZY- white porcelain shard with impressed floral design



Pl. 196: JZY- black and tea-dust green glazed chicken-leg vase shards



Pl. 197: JZY- green and black glazed shards



Pl. 198: JZY- black glazed stoneware bowl shard



Pl. 199: JZY- black glazed stoneware shard



Pl. 200: JZY- black glazed shards with carved floral designs



Pl. 201: JZY- black stoneware shard with impressed design



Pl. 203: JZY- black glazed stoneware shards



Pl. 202: JZY- brown glazed stoneware shard



Pl. 204: JZY- black galzed stoneware shard





Pl. 205: JZY- white bowl with incised designs



Pl. 206: JZY- white vase



Pl. 207: JZY- white ewer



Pl. 208: JZY- white jar



Pl. 209: JZY- white porcelain bowl with cover



Pl. 210: JZY- black glazed bowl



Pl. 211: JZY- black galzed jar with carved designs



Pl. 212: JZY- bobbin shaped supporting instrument



Pl. 213: JZY- saggar fragments



Pl. 214: XYY (Dadong kiln site)- white stoneware shards



Pl. 215: XYY (Dadong kiln site)- white stoneware shards



Pl. 216: XYY (Dadong kiln site)- white stoneware shards



Pl. 217: XYY (Dadong kiln site)- outer black and inner white stoneware shards



Pl. 218: XYY (Dadong kiln site)- white porcelain shard



Pl. 219: XYY (Dadong kiln site)- tea-dust green glazed shard



Pl. 220: XYY (Dadong kiln site)- black and brown glazed shards



Pl. 221: XYY (Dadong kiln site)- firing instruments



Pl. 222: EMK (Zhangwagou kiln site)-
tea-dust green glazed bowl shard



Pl. 223: EMK (Zhangwagou kiln site)-
brown and tea-dust green glazed
stoneware shards



Pl. 224: EMK (Zhangwagou kiln site)- black and brown glazed stoneware shards



Pl. 225: EMK (Zhangwagou kiln site)- tea-dust green glazed bowl shard



Pl. 226: EMK (Zhangwagou kiln site)-
tea-dust green glazed bowl shard



Pl. 227: EMK (Zhangwagou kiln site)- black
and tea-dust green glazed stoneware
shards with incised designs



Pl. 228: EMK (Zhangwagou kiln site)- outer
black and inner white glazed shard



Pl. 229: EMK (Zhangwagou kiln site)- black
glazed stoneware shards



Pl. 230: EMK (Zhangwagou kiln site)- black glazed stoneware



Pl. 231: EMK (Zhangwagou kiln site)- outer black and inner white glazed shard



Pl. 232: EMK (Zhangwagou kiln site)- black glazed bowl shard



Pl. 233: EMK (Zhangwagou kiln site)- tea-dust green glazed vase shard



Pl. 234: EMK (Zhangwagou kiln site)- tea-dust green glazed chicken-leg vase bottom



Pl. 235: EMK (Zhangwagou kiln site)- black glazed lamp shard



Pl. 236: EMK (Zhangwagou kiln site)- black glazed chicken-leg vase bottom



Pl. 237: EMK (Zhangwagou kiln site)- black glazed shard with incised design



Pl. 238: EMK (Zhangwagou kiln site)- black glazed shards



Pl. 239: EMK (Zhangwagou kiln site)- black glazed stoneware shard with incised design



Pl. 240: EMK (Zhangwagou kiln site)- white bowl with incised design



Pl. 241: EMK (Zhangwagou kiln site)- white stoneware bowl



Pl. 242: EMK (Zhangwagou kiln site)-
bobbin shaped supporting instrument



Pl. 243: EMK (Zhangwagou kiln site)-
round supporting pad



Pl. 244: EMK (Zhangwagou kiln site)- mold
instrument



Pl. 245: EMK (Zhangwagou kiln site)-
bobbin shaped supporting instrument



Pl. 246: EMK (Zhangwagou kiln site)-
supporting spurs



Pl. 247: EMK (Zhangwagou kiln site)-
cylinder shaped supporting instrument



Fig. 23: Peony spray on oblong lobed dish
(detail from Cat. 1177)



Fig. 24: Peony spray on oblong lobed dish
(detail from Cat. 1181)



Fig. 25: Peony spray on oblong lobed dish (detail from Cat. 1182)



Fig. 26: Peony spray on silver ewer and bowl from a store of silver found near Balin Right Banner, Inner Mongolia, c. 1100. (Ba Youwen & Cheng Shun 1980, 45-51)



Fig. 27: Peony spray on inkstone (detail from Cat. 1206)

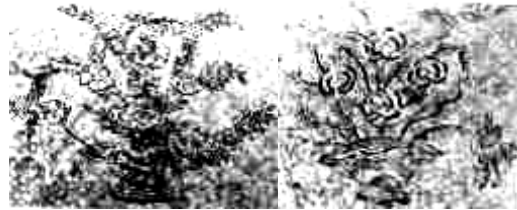

Pl. 248: Plant and flower pot painted on a stone coffin of a tomb at Erbadi, Keshiketeng Banner, Inner Mongolia (Xiang Chunsong 1984, pls. 10, 72)



Pl. 249: Peony spray-Mold for impressing decoration on the interior of lobed dishes. Excavated from GWYC kiln site. (Feng Yongqian 1984a, 386-392, fig.3)

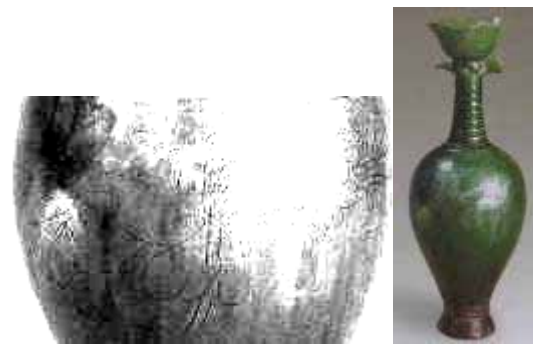

Pl. 250: Peony spray on phoenix-head vase (detail from Cat. 354)



Pl. 251: Peony spray on phoenix-head vase
(detail from Cat. 356)



Pl. 252: Peony spray on carinate shoulder
bottle (detail from Cat. 291)



Pl. 253: Peony spray on long-neck vase
(detail from Cat. 342)



Pl. 254: Peony spray on long-neck vase
(detail from Cat. 314)



Pl. 255: Peony spray on long-neck vase
(detail from Cat. 332)



Pl. 256: Peony spray on basin (detail from
Cat. 711)

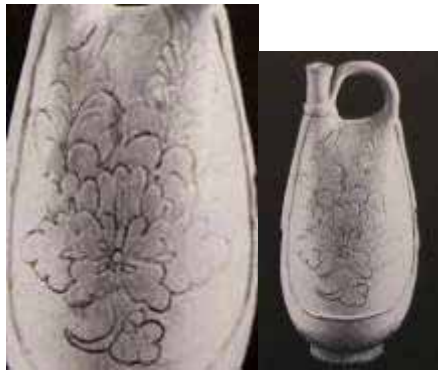

Pl. 257: Peony spray on bag-shaped pilgrim flask (detail from Cat. 163)



Pl. 258: Peony spray on bag-shaped pilgrim flask (detail from Cat. 164)



Pl. 259: Peony spray on bag-shaped pilgrim flask (detail from Cat. 162)



Pl. 260: Peony spray on bag-shaped pilgrim flask (detail from Cat. 216)

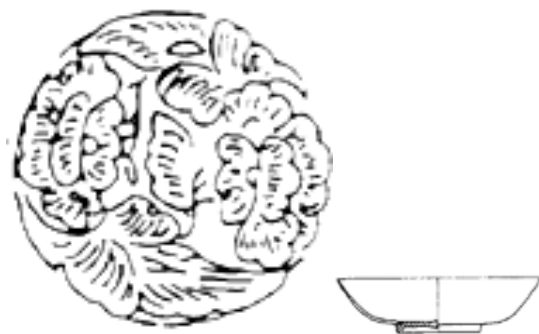

Fig. 28: Peony spray on the interior of dish (detail from Cat. 1029)



Fig. 29: Peony spray on the interior of dish (detail from Cat. 1072)



Fig. 30: Peony spray on the interior of dish (Zhu Zifang & Xu Ji 1983 168-95, fig. 20:2)



Fig. 31: Peony spray with two leaves extending horizontally outwards on round dish (detail from Cat. 1037)



Pl. 261: Peony spray with two leaves extending horizontally outwards on round dish (detail from Cat. 1055)

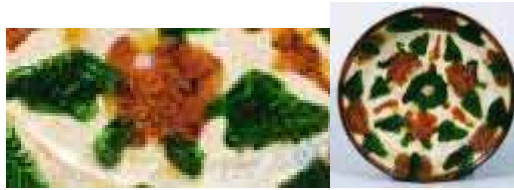

Pl. 262: Peony spray with two leaves extending horizontally outwards on round dish (detail from Cat. 1057)



Fig. 32: Peony spray with two leaves extending horizontally outwards on inkstone (detail from Cat. 1206)

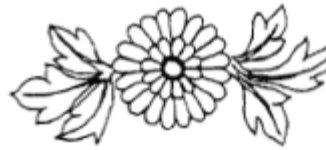

Fig. 33: Flower spray with two leaves extending horizontally outwards on inkstone (detail from Cat. 1206)



Fig. 34: Flower spray with four leaves pointing outwards on square dish (detail from Cat. 1148)



Fig. 35 Flower spray with two leaves extending horizontally outwards on brush-washer (detail from Cat. 1203)



Pl. 263: Peony spray on the shoulder of jar (detail from Cat. 614)



Pl. 264: Peony spray on jar (detail from Cat. 664)

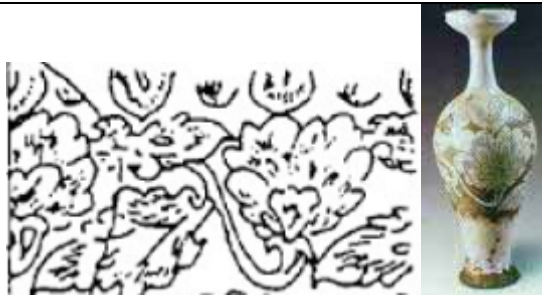

Fig. 36: Peony scroll on long-neck vase (detail from Cat. 301)



Pl. 265: Peony scroll on long-neck vase (detail from Cat. 304)



Pl. 266: Peony scroll on long-neck vase
(detail from Cat. 303)



Pl. 267: Peony scroll on big jar (detail from
Cat. 614)



Pl. 268: Peony scroll on big jar (detail from
Cat. 615)



Pl. 269: Peony scroll on big jar (detail from
Cat. 611)



Pl. 270: Peony scroll on big jar (detail from
Cat. 673)



Pl. 271: Peony scroll on big jar (detail from
Cat. 676)



Pl. 272: Peony scroll on big jar (detail from
Cat. 677)



Pl. 273: Peony scroll on big jar (detail from
Cat. 679)

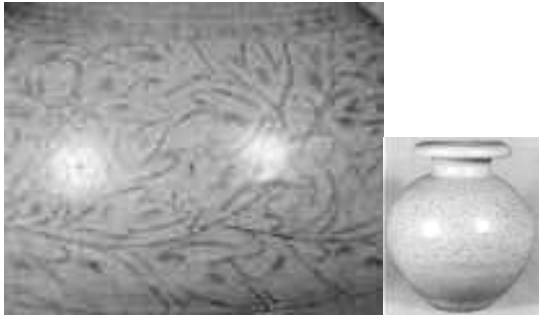

Pl. 274: Peony scroll on big jar (detail from Cat. 621)



Pl. 275: Peony scroll on vase (detail from Cat. 570)



Pl. 276: Peony scroll on vase (detail from Cat. 571)



Pl. 277: Peony scroll on vase (detail from Cat. 572)



Pl. 278: Peony scroll on vase (detail from Cat. 369)

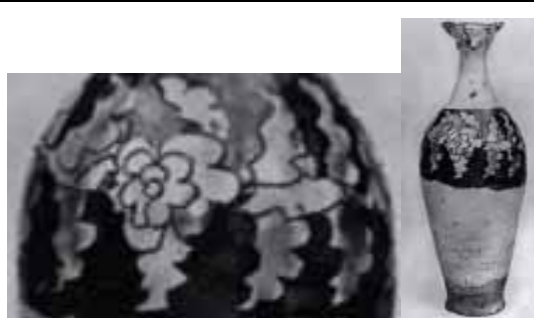

Pl. 279: Peony scroll on vase (detail from Cat. 370)



Pl. 280: Peony scroll on ewer (detail from Cat. 491)



Fig. 37: Detail from an epitaph of ZKY tomb (Deng Baoxue 1983, 30-38, fig. 15)



Fig. 38: Detail from a wood coffin of JFYZ tomb (Xiang Chunsong 1984, pl.76)



Pl. 281: Peony scroll on inkstone (detail from Cat. 1204)

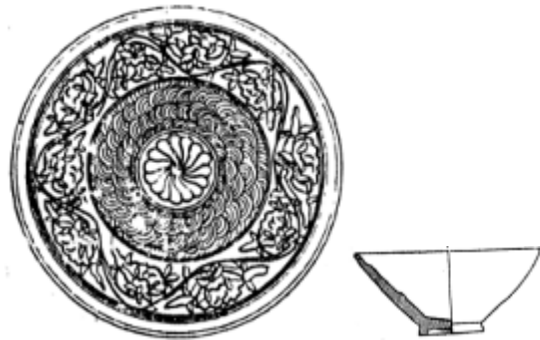

Fig. 39: Peony scroll on the interior wall of bowl (detail from Cat. 892)



Fig. 40: : Peony scroll on the interior wall of bowl (detail from Cat. 854)



Pl. 282: Herbaceous peony on basin (description see Cat. 742)



Pl. 283: Herbaceous peony on basin (description see Cat. 741)



Pl. 284: Herbaceous peony on long-neck vase (detail from Cat. 312)



Pl. 285: Herbaceous peony on basin vase (description see Cat. 313)



Fig. 41: Overlapping Lotus petals on jar (description see Cat. 653)

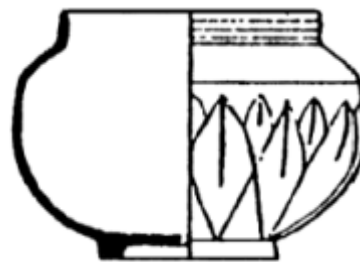

Fig. 42: Overlapping Lotus petals on jar (description see Cat. 654)

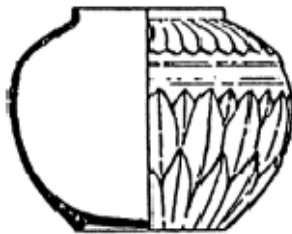

Fig. 43: Overlapping Lotus petals on jar (description see Cat. 655)

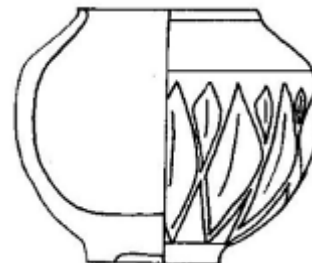

Fig. 44: Overlapping Lotus petals on jar (description see Cat. 661)

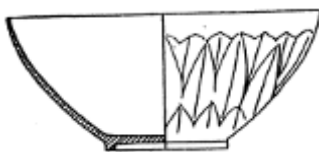

Fig. 45: Overlapping Lotus petals on bowl (description see Cat. 842)



Fig. 46: Overlapping Lotus petals on bowl (description see Cat. 952)

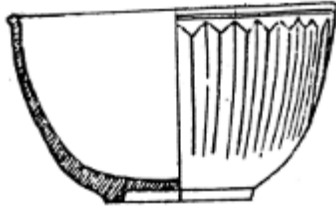

Fig. 47: Overlapping Lotus petals on bowl
(description see Cat. 957)



Pl. 286: Overlapping Lotus petals on bowl
(description see Cat. 953)



Pl. 287: Overlapping Lotus petals on bowl
(description see Cat. 955)

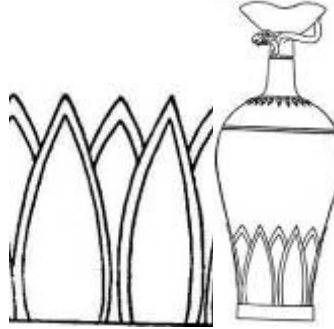

Fig. 48: Overlapping Lotus petals on
phoenix-head vase (description see Cat.
351)



Fig. 49: Overlapping Lotus petals on
long-neck vase (detail from Cat. 298)

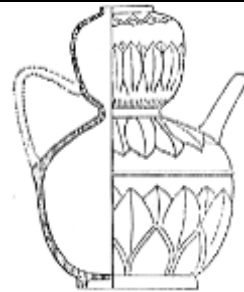

Fig. 50: Overlapping Lotus petals on ewer
(description see Cat. 452)

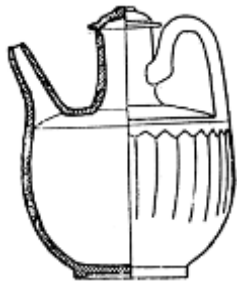

Fig. 51: Overlapping Lotus petals on ewer
(description see Cat. 393)

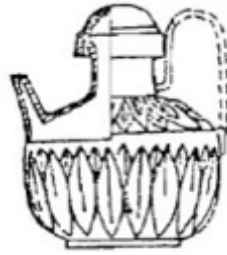

Fig. 52: Overlapping Lotus petals on ewer
(description see Cat. 396)

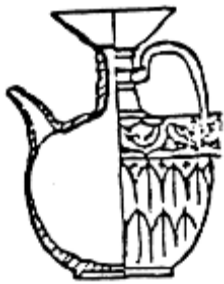

Fig. 53: Overlapping Lotus petals on ewer
(description see Cat. 430)



Fig. 54: Overlapping Lotus petals on ewer
(description see Cat. 442)



Pl. 288: Overlapping Lotus petals on ewer
(description see Cat. 395)



Fig. 55: Overlapping Lotus petals on ewer
(description see Cat. 405)



Pl. 289: Overlapping Lotus petals on vase
(detail from Cat. 570)



Pl. 290: Overlapping Lotus petals on vase
(detail from Cat. 571)



Fig. 56 : Lotus rosette-detail from a silver cup with handle. Tang dynasty.
(Gyllensvard 1957, fig. 87:e)



Fig. 57: Lotus rosette-detail from a three-colored tray. Tang dynasty.
(Gyllensvard 1957, fig. 87:i)



Fig. 58: Lotus rosette-detail from a stone stele of a Liao tomb at Xigushan, Liaoning
(Yan Wanzhang 1957, 69-82. fig.1)



Fig. 59: Lotus rosette-detail from a wall painting of a Liao tomb at Xuanhua, Hebei.
(Hebeisheng wenwu guanlichu et al. 1935, 31-39, pl.1)



Fig. 60: Lotus rosette on Liao ceramic basin (detail from Cat. 176)

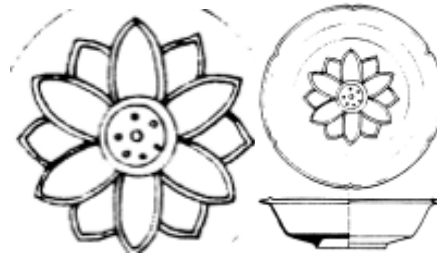

Fig. 61: Lotus rosette on Liao ceramic basin (detail from Cat. 715)



Pl. 291: Lotus rosette on Liao ceramic basin (detail from Cat. 716)



Fig. 62: Lotus rosettes on oblong lobed dish (detail from Cat. 1191)



Fig. 63: Lotus rosettes on oblong lobed dish (detail from Cat. 1200)



Fig. 64: Lotus rosettes on oblong lobed dish (detail from Cat. 1184)

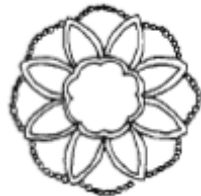

Fig. 65: Metallic origin of lotus rosettes ornament on Tang gold or silver wares (Qi Dongfang 1999)

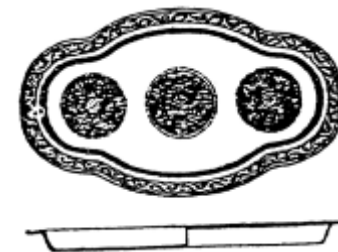

Fig. 66: Lotus rosettes on silver oblong lobed dish (detail from Cat. 1172)

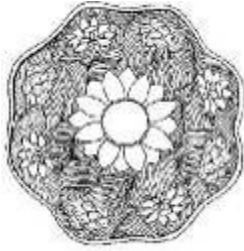

Fig. 67: Lotus rosettes on flat-base dish
(detail from Cat. 1113)

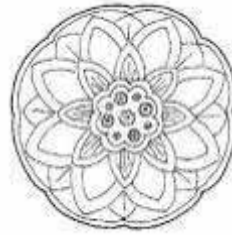

Fig. 68: Lotus rosette on flat-base dish
(detail from Cat. 1112)



Fig. 69: Lotus rosette on flat-base dish
(detail from Cat. 1114)



Fig. 70: S-curved petals on ring-foot dish
(detail from Cat. 1050)



Fig. 71: Detail from the cover of a
three-colored box (Wirgin 1960, 25-46,
fig.8:g)



Fig. 72: Lotus rosette on ring-foot dish
(detail from Cat. 1053)

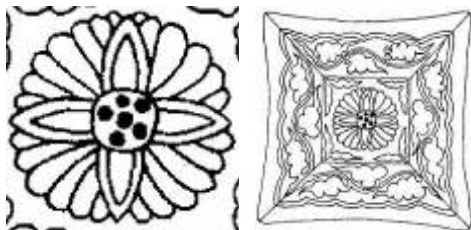

Fig. 73: Lotus rosette detail from a square
dish mold discovered in LQW kiln site
(Beijingshi wenwu yanjiusuo 2002.)



Fig. 74: Lotus rosette detail from a square
dish mold discovered in LQW kiln site
(Beijingshi wenwu yanjiusuo 2002.)



Pl. 292: S-curved petals on the shoulder of long-neck vase (detail from Cat. 304)



Pl. 293: S-curved petals on the shoulder of phoenix-head vase (detail from Cat. 356)

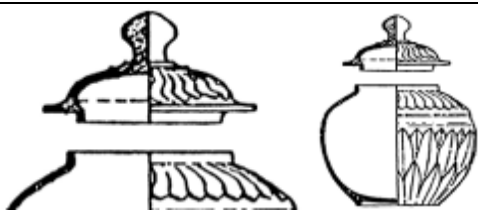

Fig. 75: S-curved petals on the jar and cover (detail from Cat. 655)

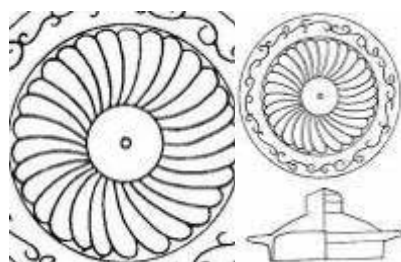

Fig. 76: S-curved petals on cover from LQW kiln site (Beijingshi wenwu yanjiusuo 2002)



Fig. 77: Scrolling vines on bag-shaped pilgrim flask (detail from Cat. 82)



Fig. 78: Scrolling vines on bag-shaped pilgrim flask (detail from Cat. 89)



Fig. 79: Scrolling vines on bag-shaped pilgrim flask (detail from Cat. 90)



Fig. 80: Scrolling vines on bag-shaped pilgrim flask (detail from Cat. 92)

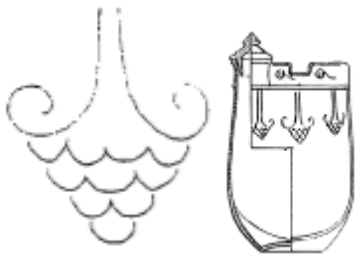

Fig. 81: Scrolling vines on bag-shaped pilgrim flask (detail from Cat. 62)



Fig. 82: Scrolling vines on bag-shaped pilgrim flask (detail from Cat. 70)



Pl. 294: Scrolling vines on bag-shaped pilgrim flask (detail from Cat. 72)



Pl. 295: Leaf design on Type B of Group2 bag-shaped pilgrim flask (detail from Cat. 219)



Fig. 83 : Leaf scroll on the mouth rim of oblong lobed dish (detail from Cat. 1177)



Fig. 84 : Leaf scroll on the mouth rim of oblong lobed dish (detail from Cat. 1181)



Fig. 85 : Leaf scroll on the mouth rim of oblong lobed dish (detail from Cat. 1185)



Fig. 86 : Leaf scroll on the mouth rim of oblong lobed dish (detail from Cat. 1198)

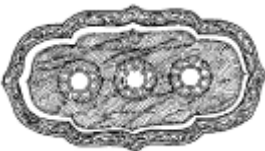

Fig. 87 : Leaf scroll on the mouth rim of oblong lobed dish (detail from Cat. 1186)

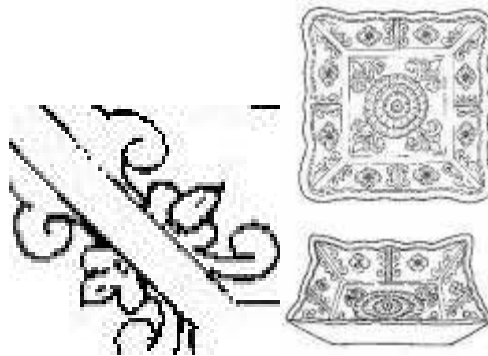

Fig. 88 : Leaf scroll on square dish (detail from Cat. 1146)



Fig. 89 : Leaf scroll on the mouth rim of square dish mold from LQW kiln site(Beijingshi wenwu yanjiusuo 2002)

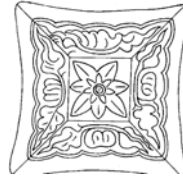

Fig. 90 : Leaf scroll on the mouth rim of square dish mold from LQW kiln site (detail from Cat. 1143)

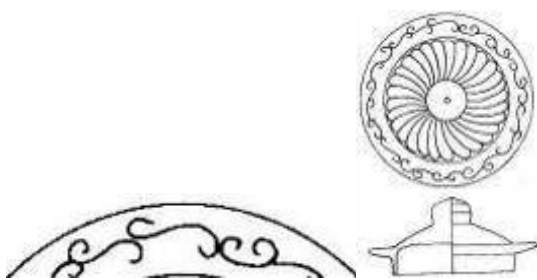

Fig. 91 : Leaf scroll on cover from LQW kiln site(Beijingshi wenwu yanjiusuo 2002)



Fig. 92: Scroll cloud on inkstone (detail from Cat. 1206)



Fig. 93: Leaf scroll on shoulder of ewer (detail from Cat. 422)



Pl. 296: Leaf scroll on handle of ewer (detail from Cat. 465)



Fig. 94: Scroll cloud-detail from a stone stele of a tomb at xigushan, Jinxi, Liaoning. (Yan Wanzhang 1957, 69-82, fig.1)



Fig. 95: Plantain leaves on ewer and bowl (detail from cat. 960, Cat. 418)

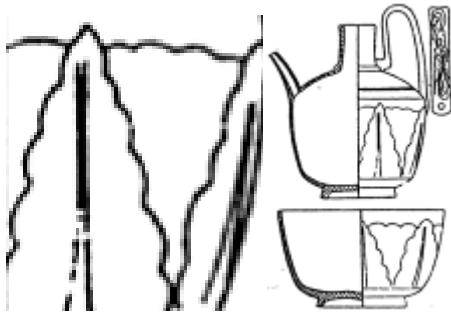

Fig. 96: Plantain leaves on ewer and bowl (detail from Cat. 416)

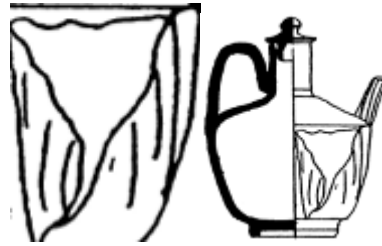

Fig. 97: Plantain leaves on ewer (detail from Cat. 419)

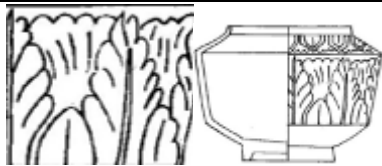

Fig. 98: Plantain leaves on jar (detail from Cat. 663)



Fig. 99: Plantain leaves on jar (detail from Cat. 662)

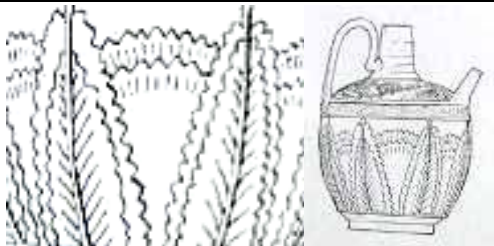

Fig. 100: Plantain leaves on ewer (detail from Cat. 422)

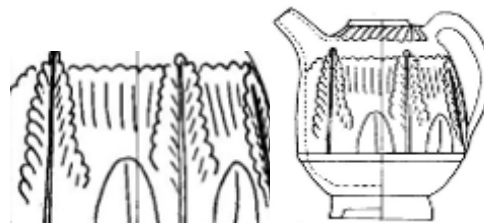

Fig. 101: Plantain leaves on ewer

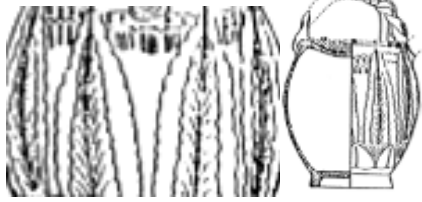

Fig. 102: Plantain leaves on ewer (detail from Cat. 492)

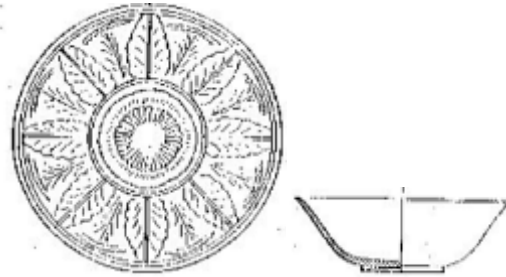

Fig. 103: Plantain leaves on bowl (detail from Cat. 921)

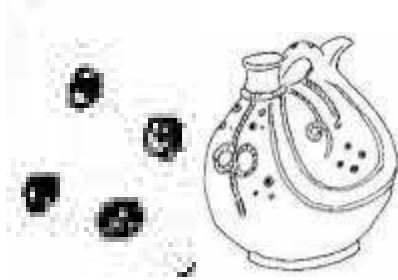

Fig. 104: Stippling plum blossom on bag-shaped pilgrim flask (detail from Cat. 220)

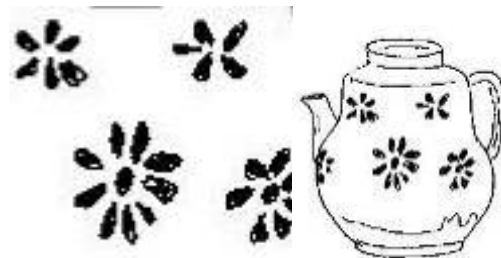

Fig. 105: Stippling plum blossom on ewer (detail from Cat. 472)



Pl. 297: Stippling plum blossom on jar (detail from Cat. 610)



Pl. 298: Stippling plum blossom on jar (detail from Cat. 672)



Pl. 299: Stippling plum blossom on bowl (detail from Cat. 997)



Fig. 106: Butterfly on triangular dish, Five Dynasties. (detail from Cat. 1158)

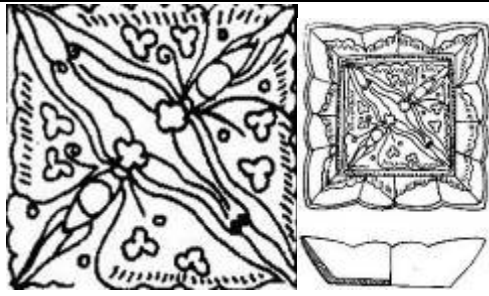

Fig. 107: Butterfly on square dish (detail from Cat. 1134)

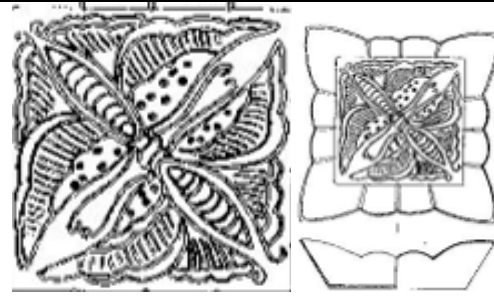

Fig. 108: Butterfly on square dish (detail from Cat. 1135)



Pl. 300: : Butterfly on Tang silver box , Tang dynasty. (detail from Cat. 1160)

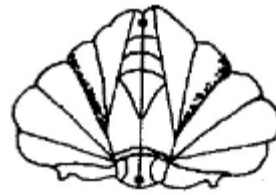

Fig. 109: Butterfly on Liao amber box (detail from Cat. 1161)



Fig. 110: Detail from a Yue ware dish (Feng Xianming, 1973, 20-29, fig.2)



Fig. 111: Detail from a Ding ware dish (Feng Xianming, 1973, 20-29, fig.1)

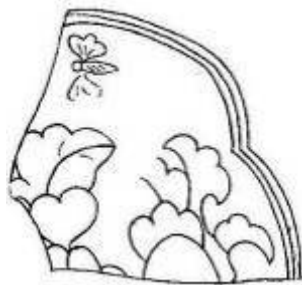

Fig. 112: Butterfly (or bee) on a bowl shard from GWYC kiln site (Lu Jing 2003, 323, pl. 4-370)



Fig. 113: Butterfly (or bee) on a bowl shard from GWYC kiln site (Lu Jing 2003, 323, pl. 4-369)

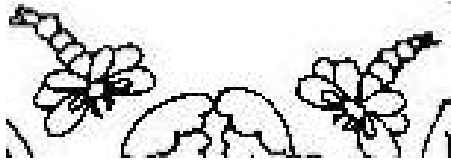

Fig. 114: Butterfly (or bee) on oblong lobed dish (detail from Cat. 1181)



Fig. 115: Butterfly (or bee) on oblong lobed dish (detail from Cat. 1182)



Fig. 116: Butterfly (or bee) on oblong lobed dish (detail from Cat. 1177)



Pl. 301: Butterfly on ewer (detail from Cat. 491)



Pl. 302: Butterfly on ewer (detail from Cat. 489)



Pl. 303: Butterfly on ewer (detail from Cat. 425)

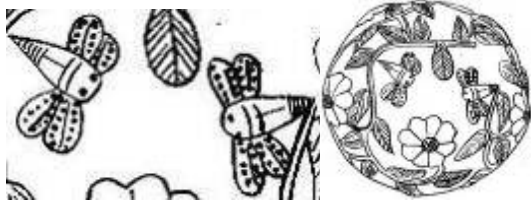

Fig. 117: Butterflies on ocarina (detail from Cat. 1225)

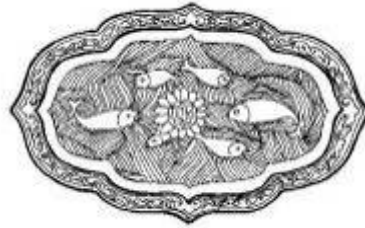

Fig. 118: Fish on oblong lobed dish (description see Cat. 1184, Cat. 1185)



Pl. 304 : Fish on oblong lobed dish, Tang dynasty. (description see Cat. 1167)



Pl. 305: Fish on basin (description see Cat. 732)

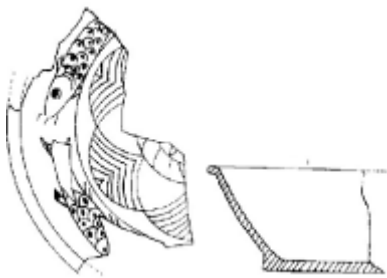

Fig. 119: Fish on basin (description see Cat. 731)



Pl. 306: Fish on basin (description see Cat. 735)

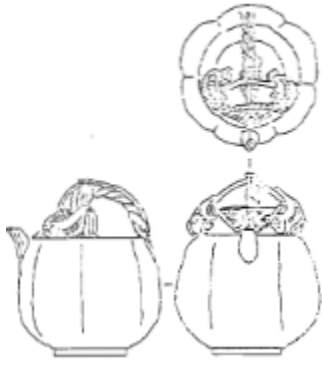

Fig. 120: Fish on the handle of ewer
(description see Cat. 489)



Fig. 121: Dragon-fish (makara) on stone
carving at Amaravati, India. Circa 200-205
B.C. (after Cen Rui 1983, 78-80, fig.2)



Fig. 122: Dragon-fish (makara) on coffin of
the tomb of Li He at Shangshengcun,
Sanyuanxian, Shaanxi, Sui Dynasty. (after
Cen Rui 1983, 78-80, 85 fig.1: left)



Fig. 123: Dragon-fish (makara) on coffin of
the tomb of Li He at Shangshengcun,
Sanyuanxian, Shaanxi, Sui Dynasty. (after
Zeng Yu 1984, 33-36, fig.2)



Fig. 124: Detail from a silver plate
unearthed at Dingmaoqiao, Dantu, Jiangsu.
Tang dynasty. (Zeng Yu 1984, 33-36, fig.
6:A)

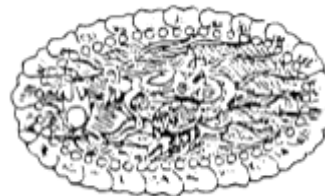

Fig. 125: Detail from a gold cup unearthed
at Xian, Shaanxi. Tang dynasty. (He Lin et
al. 1983, p.14)



Fig. 126: Detail from a silver plate unearthed at Kalaqin Banner, Inner Mongolia. Tang dynasty. (Cen Rui 1983, 78-80, fig.5)



Fig. 127: Gilt silver plaque decorated with two dragon-fish chasing pearls. Unearthed from SQ1 tomb, Beipiao, Liaoning. Liao product. 10th century. L: 18cm, W: 10.5cm. (Xu Yulin 1971, 44-51, fig.5)



Pl. 307: dragon-fish formed Greeware ewer unearthed from SQ1 tomb, Beipiao, Liaoning. Made at a Northern Song kiln. 10th-early 11th Century. L:14cm (Xu Yulin 1971, 44-51)



Pl. 308: Dragon-fish formed ewer (description see Cat. 507)

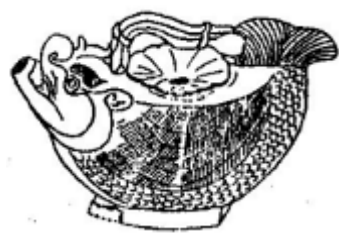

Fig. 128: : Dragon-fish formed ewer (description see Cat. 508)



Pl. 309: Dragon-fish formed ewer (description see Cat. 523)



Fig. 129: Dragon-fish formed ewer
(description see Cat. 506)



Pl. 310: Dragon-fish formed ewer
(description see Cat. 505)



Pl. 311: Dragon-fish formed ewer
(description see Cat. 504)



Pl. 312: Dragon-fish formed ewer
(description see Cat. 503)



Fig. 130: Phoenix on a shard from GWYC kiln. (Zhou Jie 1973, 241-243, fig:2)

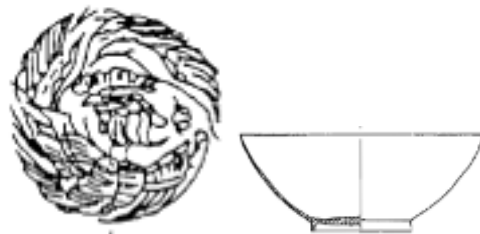

Fig. 131: Phoenix incised on a white glazed bowl unearthed from GYY tomb, dated to 1026. D: 21cm. (Zhu Zifang & Xu Ji 168-195, fig. 4:9)



Fig. 132: Phoenix incised on a guan marked white glazed dish unearthed from YMT7. Probably Ding ware. 10th century. D: 15.6 cm. (Feng Yongqian 1975, 40-48, fig. 1:1)



Pl. 313: Phoenix on ewer (detail from Cat. 425)



Pl. 314: Dragon on ewer (detail from Cat. 428)



Pl. 315: Dragon on ewer (detail from Cat. 429)



Fig. 133: Dragon on bag-shaped pilgrim flask (detail from Cat. 66)



Pl. 316: Dragon on bag-shaped pilgrim flask (detail from Cat. 86)



Pl. 317: Monkey on bag-shaped pilgrim flask (detail from Cat. 54)

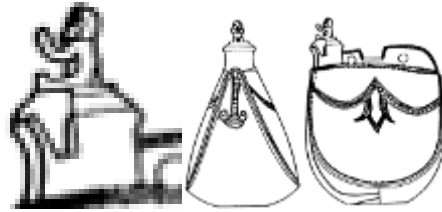

Fig. 134: Monkey on bag-shaped pilgrim flask (detail from Cat. 56)



Pl. 318: Monkey on bag-shaped pilgrim flask (detail from Cat. 59)



Pl. 319: Monkey on bag-shaped pilgrim flask (detail from Cat. 87)



Fig. 135: Monkey sculpture (detail from Cat. 1296)

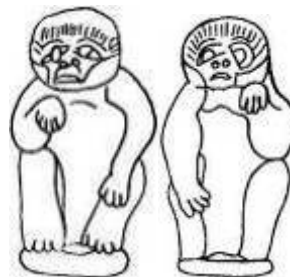

Fig. 136: : Monkey sculptures unearthed from LQW kiln (Beijingshi wenwu yanjiusuo 2002)



Fig. 137: Human motif on bag-shaped pilgrim flask (detail from Cat. 70)



Pl. 320: Human tamping lion motif on brush-washer (detail from Cat. 1213)



Pl. 321: Human motif on jar (detail from Cat. 687)



Pl. 322: Human figure (description see Cat. 1312)



Pl. 323: Human figure (description see Cat. 1313)



Pl. 324: Human figure (description see Cat. 1314)



Pl. 325: Human figure (description see Cat. 1315)



Pl. 326: Human figure (description see Cat. 1316)



Pl. 327: Human figure (description see Cat. 1317)



Pl. 328: Human figure (description see Cat. 1318)



Pl. 329: Human figure (description see Cat. 1320)



Pl. 330: Human figure (description see Cat. 1321)



Pl. 331: Human figure (description see Cat. 1322)



Fig. 138: Firing-ball motif on bag-shaped pilgrim flask (detail from Cat. 57)



Fig. 139: Firing-ball motif on bag-shaped pilgrim flask (detail from Cat. 60)



Pl. 332: Firing-ball motif on three-colored tile from LQW kiln (Beijingshi wenwu yanjiusuo 2002)

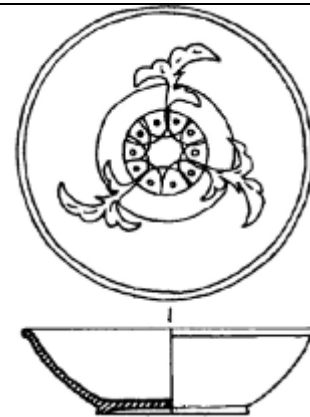

Fig. 140: Whirling floral design on basin (description see Cat. 748)

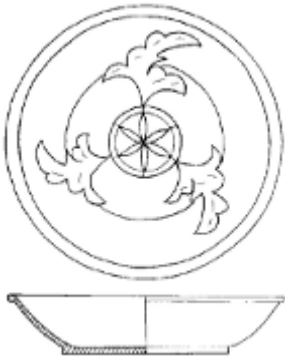

Fig. 141: Whirling floral design on basin
(description see Cat. 749)

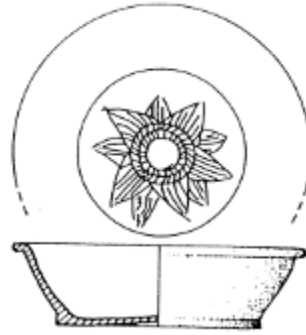

Fig. 142: Sun floral design on basin
(description see Cat. 727)



Fig. 143: Whirling floral design on basin
(description see Cat. 729)

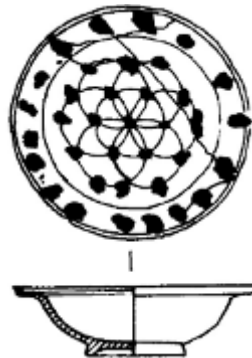

Fig. 144: Net floral design on basin
(description see Cat. 714)

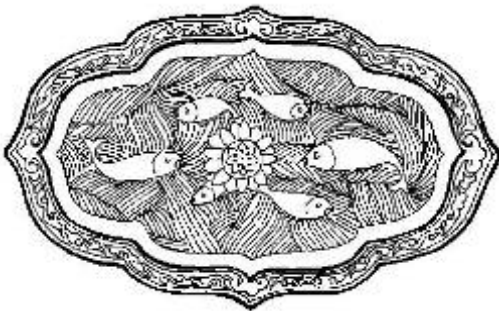

Fig. 145: Layout of the designs on
three-colored oblong lobed dish-Type A
(detail from Cat. 1185)



Fig. 146: Layout of the designs on
three-colored oblong lobed dish-Type B
(detail from Cat. 1181)

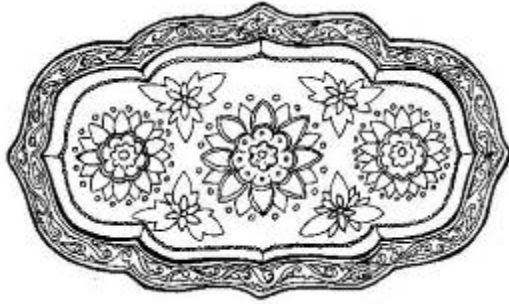

Fig. 147: Layout of the designs on three-colored oblong lobed dish-Type C (detail from Cat. 1201)

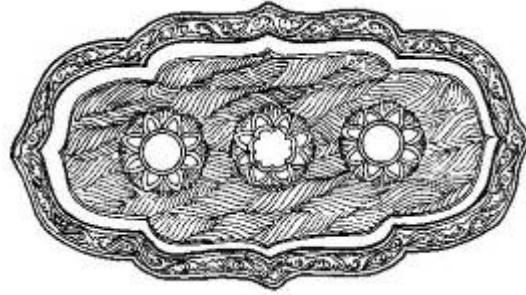

Fig. 148: Layout of the designs on three-colored oblong lobed dish-Type D (detail from Cat. 1186)



Fig. 149: Layout of the designs on three-colored eight lobed dish-Type A (detail from Cat. 1111)

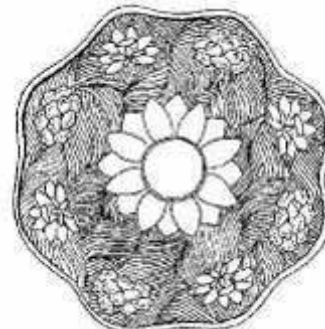

Fig. 150: Layout of the designs on three-colored eight lobed dish-Type B (detail from Cat. 1110)



Fig. 151: Layout of the designs on three-colored eight lobed dish-Type C (detail from Cat. 1114)

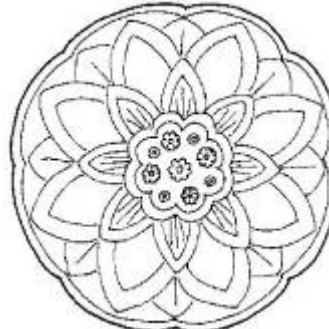

Fig. 152: Layout of the designs on three-colored eight lobed dish-Type D (detail from Cat. 1112)



Fig. 153: Layout of the designs on three-colored square dish (detail from Cat. 1148)

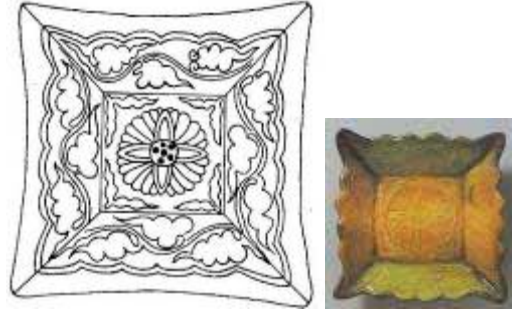

Fig. 154: Layout of the designs on three-colored square dish (detail from Cat. 1144)



Fig. 155: Layout of the designs on three-colored round dish- Type A (detail from Cat. 1037)



Fig. 156: Layout of the designs on three-colored round dish- Type B (Lu Jing 2003, 331, pl. 4-422)



Fig. 157: Layout of the designs on three-colored round dish- Type C (Lu Jing 2003, 332, pl. 4-424)

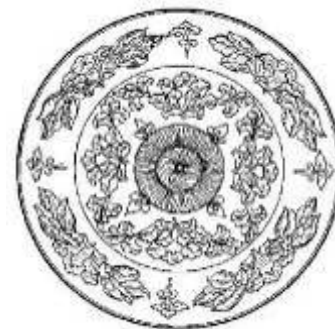

Fig. 158: Layout of the designs on three-colored round dish- Type D (detail from Cat. 1050)

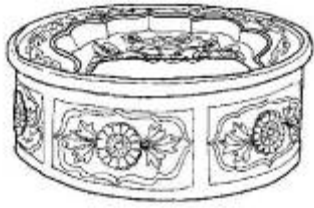

Fig. 159: Layout of the designs on outer wall of three-colored inkstone (description see Cat. 1206)



Pl. 333: Layout of the designs on outer wall of three-colored inkstone (description see Cat. 1204)



Pl. 334: Layout of the designs on outer wall of three-colored inkstone (description see Cat. 1210)



Pl. 335: Layout of the designs on outer wall of three-colored inkstone (description see Cat. 1214)



Fig. 160: Layout of the designs on outer wall of three-colored inkstone (description see Cat. 1213)



Fig. 161: Layout of the designs on over surface of three-colored inkstone (description see Cat. 1206)



Pl. 336: Layout of the designs on over surface of three-colored inkstone (description see Cat. 1210)



Pl. 337: Layout of the designs on over surface of three-colored inkstone (description see Cat. 1214)

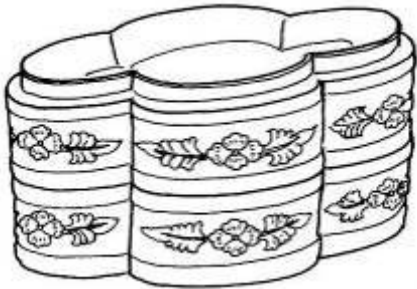

Fig. 162: Layout of the designs on outer wall of three-colored box (description see Cat. 1276)



Pl. 338: Layout of the designs on outer wall of three-colored box (description see Cat. 1274)



Pl. 339: Layout of the designs on outer wall of yellow glazed box (description see Cat. 1273)



Pl. 340: Layout of the designs on outer wall of three-colored box (description see Cat. 1277)



Pl. 341: Layout of the designs on outer wall of three-colored box (description see Cat. 1278)



Pl. 342: Inscription by ink on jar bottom (detail from Cat. 681)



Pl. 343: Inscription incised on shoulder of chicken-leg vase (Lu Jing 2003, 335, pl. 4-448)



Pl. 344: Inscription incised on shoulder of chicken-leg vase (detail from Cat. 551)



Pl. 345: Inscription incised on shoulder of chicken-leg vase (detail from Cat. 554)



Pl. 346: Inscription incised on shoulder of chicken-leg vase (detail from Cat. 568)



Pl. 347: Inscription incised on shoulder of chicken-leg vase (Lu Jing 2003, 335, pl. 4-445)



Pl. 348: Inscription incised on shoulder of chicken-leg vase (Lu Jing 2003, 335, pl. 4-446)



Pl. 349: Inscription incised on three-colored tile (Beijingshi wenwu yanjiusuo 2002)



Fig. 163: Inscription incised on shoulder of vase (Lu Jing 2003, 335, pl. 4-443)



Pl. 350: Inscription incised on base of basin (Lu Jing 2003, 336, pl. 4-459)



Pl. 351: Inscription incised on base of vase (detail from Cat. 582)

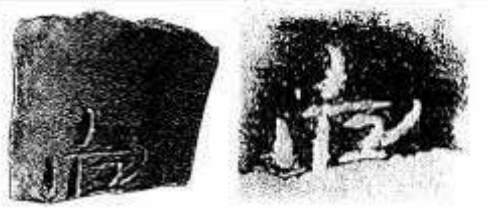

Pl. 352: Guan mark on firing instrument from GWYC kiln

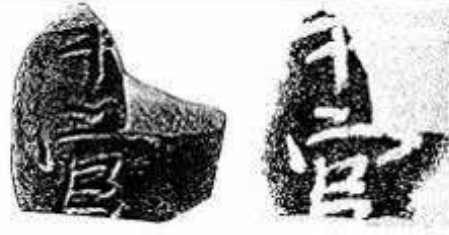

Pl. 353: Xinguan mark on firing instrument from GWYC kiln



Fig. 164: Guan mark on bottle (detail from Cat. 286)

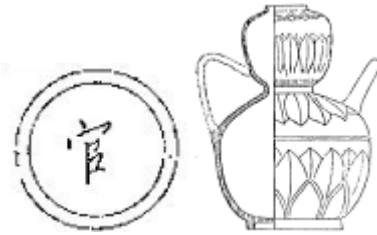

Fig. 165: Guan mark on ewer (detail from Cat. 452)

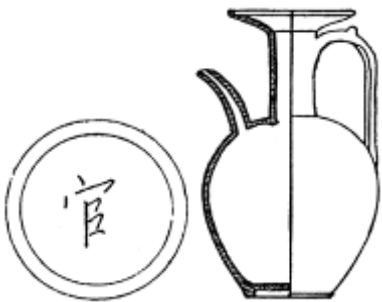

Fig. 166: Guan mark on ewer (detail from Cat. 433)

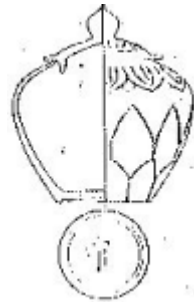

Fig. 167: Guan mark on jar (detail from Cat. 657)



Pl. 354: Guan mark on bowl (detail from Cat. 884)



Pl. 355: Guan mark on bowl (detail from Cat. 972)



Pl. 356: Guan mark on lugged vase (detail from Cat. 245)



Pl. 357: Guan mark on long neck vase (detail from Cat. 293)



Pl. 358: Guan mark on bowl (detail from Cat. 407)



Pl. 359: Guan mark on bowl (detail from Cat. 896)



Fig. 168: Mural painting of GYY tomb at Guyingzi, Chaoyang, Liaoning Province, dated to 1026. (after Zhu Zifang & Xu Ji 1983, 168-95, fig.13)

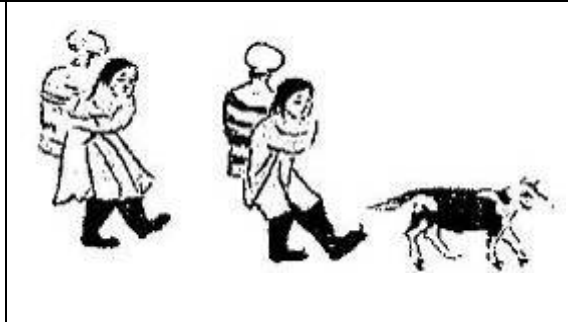

Fig. 169: : Mural painting of EBD tomb at Keshiketeng Banner, Inner Mongolia. (after Xiang Chunsong 1984, 89-90)



Fig. 170: Mural painting of a Liao tomb at Kangyingzi, Aohan Banner, Inner Mongolia. (after Xiang Chunsong 1979, 22-32, fig. 11:5)



Fig. 171: : Mural painting of a Liao tomb at Kangyingzi, Aohan Banner, Inner Mongolia. (after Xiang Chunsong 1979, 22-32, fig. 11:2)



Fig. 172: : Mural painting of Southeast wall of ZGY tomb, Xuanhua, Hebei Province. (after Hebeisheng wenwu yanjiusuo 2001)

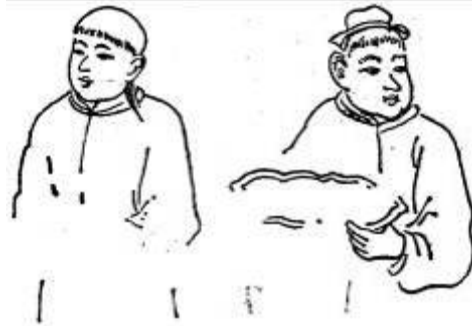

Fig. 173: : Mural painting of GYY tomb at Guyingzi, Chaoyang, Liaoning Province, dated to 1026. (after Zhu Zifang & Xu Ji 1983, 168-95, fig.13)



Pl. 360: Mural painting of east wall of the rear chamber of Tomb M10, Xuanhua, Hebei Province. (after Hebeisheng wenwu yanjiusuo 2001, pl. 18.)



Pl. 361: Stone panel with relief decoration, from the tomb of Mme Xiao and her husband, Yelu Woli, at Yangjiayingzi in Balin Left Banner (after Shen Hsueh-man 2006, 213, cat. 50b)













Pl. 362: Mural painting of south wall of the rear chamber of ZSQ tomb, at Xuanhua, Hebei Province. (after Hebeisheng wenwu yanjiusuo 2001)



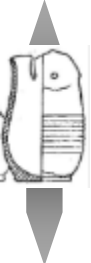







Pl. 363: Gilded silver boxes, from the relic deposit (dated 974) underneath Famen Pagoda in Fufeng, Shaanxi Province (after Shen Hsueh-man 2006, 348, Fig. 118)







CHRONOLOGICAL SEQUENCES OF LIAO CERAMICS

Period	Type	Bag-shaped pilgrim flask (Group 1)									
		Aa					Ab		B		
	AD										
Early	900s										
	910s										
	920s										
	930s										
	940s										
	950s										
	960s										
Middle	970s										
	980s										
	990s										
	1000s										
	1010s										
	1020s										
	1030s										
1040s											
1050s											
Late	1060s										
	1070s										
	1080s										
	1090s										
	1100s										
	1110s										
	1120s										

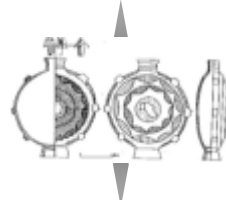
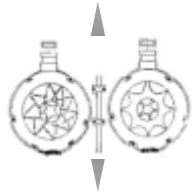











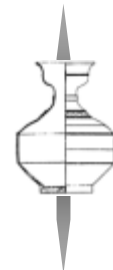

Timeline Table 1: Bag-shaped pilgrim flask (Group 1)

Period	Type	Bag-shaped pilgrim flask (Group 2)											
		Aa					Ab				B		
	AD												
Early	900s												
	910s												
	920s												
	930s												
	940s												
	950s												
	960s												
Middle	970s												
	980s												
	990s												
	1000s												
	1010s												
	1020s												
	1030s												
Late	1040s												
	1050s												
	1060s												
	1070s												
	1080s												
	1090s												
	1100s												
1110s													
1120s													









Timeline Table 2: Bag-shaped pilgrim flask (Group 2)

Period	Type	Lugged pilgrim flask			Lugged vase				
					A		B		
	AD								
Early	900s								
	910s								
	920s								
	930s								
	940s								
	950s								
	960s								
Middle	970s								
	980s								
	990s								
	1000s								
	1010s								
	1020s								
	1030s								
Late	1040s								
	1050s								
	1060s								
	1070s								
	1080s								
	1090s								
	1100s								
	1110s								
	1120s								





Timeline Table 3: Lugged pilgrim flask & Lugged vase

Period	Type	Bowl-mouth bottle						Carinate shoulder bottle						
		A		B			C	A			B			
	AD													
Early	900s													
	910s													
	920s													
	930s													
	940s													
	950s													
	960s													
Middle	970s													
	980s													
	990s													
	1000s													
	1010s													
	1020s													
	1030s													
Late	1040s													
	1050s													
	1060s													
	1070s													
	1080s													
	1090s													
	1100s													
1110s														
1120s														







Timeline Table 4: Bowl-mouth bottle & Carinate shoulder bottle

Period	Type	Long-neck vase							
		A						B	
	AD								
Early	900s								
	910s								
	920s								
	930s								
	940s								
	950s								
	960s								
Middle	970s								
	980s								
	990s								
	1000s								
	1010s								
	1020s								
	1030s								
Late	1040s								
	1050s								
	1060s								
	1070s								
	1080s								
	1090s								
	1100s								
1110s									
1120s									







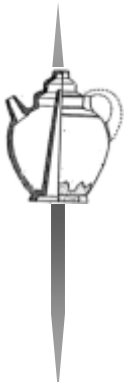
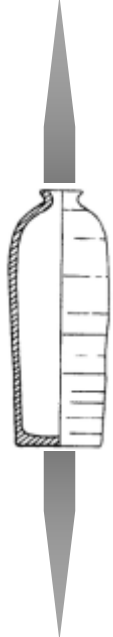

Timeline Table 5: Long-neck vase

Period	Type	Spouted ewer									
		Ca				Cb		Cc	Cd	Ce	Cf
	AD										
Early	900s										
	910s										
	920s										
	930s										
	940s										
	950s										
	960s										
Middle	970s										
	980s										
	990s										
	1000s										
	1010s										
	1020s										
	1030s										
Late	1040s										
	1050s										
	1060s										
	1070s										
	1080s										
	1090s										
	1100s										
1110s											
1120s											

Timeline Table 7: Spouted ewer2

Period	Type	Spouted ewer											
		Da	Db	Dc	Dd	De	Df	Dg	Dh	Di	Dj	Dk	DI
Early	AD												
	900s												
	910s												
	920s												
	930s												
	940s												
	950s												
	960s												
Middle	970s												
	980s												
	990s												
	1000s												
	1010s												
	1020s												
	1030s												
	1040s												
Late	1050s												
	1060s												
	1070s												
	1080s												
	1090s												
	1100s												
	1110s												
	1120s												











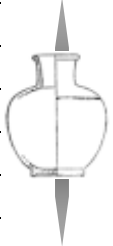
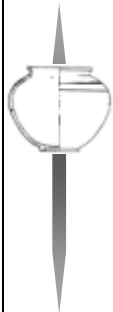

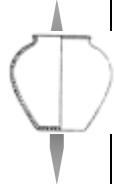

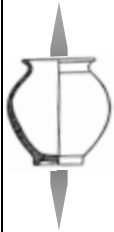

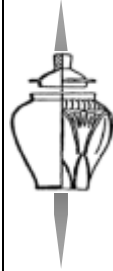

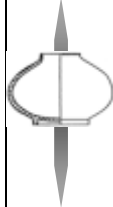
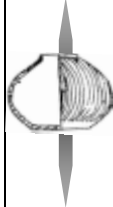
Timeline Table 8: Spouted ewer3

Period	Type	Spouted ewer					Chicken-leg vase						
		Ea	Eb	Ec	Ed	Ee	A		B				
	AD												
Early	900s												
	910s												
	920s												
	930s												
	940s												
	950s												
	960s												
Middle	970s												
	980s												
	990s												
	1000s												
	1010s												
	1020s												
Late	1030s												
	1040s												
	1050s												
	1060s												
	1070s												
	1080s												
	1090s												
	1100s												
	1110s												
	1120s												

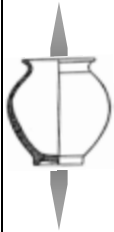

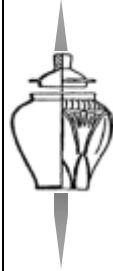

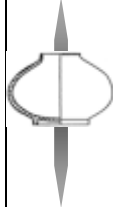
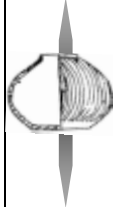

Timeline Table 9: Spouted ewer3 & Chicken-leg vase

Period	Type	Chinese-Style vase				Jar								
		A		B		C	D	Aa			Ab			
	AD													
Early	900s													
	910s													
	920s													
	930s													
	940s													
	950s													
	960s													
Middle	970s													
	980s													
	990s													
	1000s													
	1010s													
	1020s													
	1030s													
Late	1040s													
	1050s													
	1060s													
	1070s													
	1080s													
	1090s													
	1100s													
1110s														
1120s														

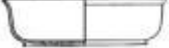



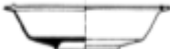





Timeline Table 10: Chinese-style vase & Jar1

Period	Type	Jar												
		Ba		Bb		Bc		Bd		Ca		Cb	Da	Db
	AD													
Early	900s													
	910s													
	920s													
	930s													
	940s													
	950s													
	960s													
Middle	970s													
	980s													
	990s													
	1000s													
	1010s													
	1020s													
	1030s													
Late	1040s													
	1050s													
	1060s													
	1070s													
	1080s													
	1090s													
	1100s													
1110s														
1120s														





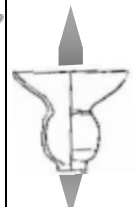

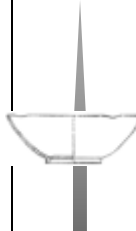

Timeline Table 11: Jar2

Period	Type	Basin							
		A				B			
	AD								
Early	900s								
	910s								
	920s								
	930s								
	940s								
	950s								
	960s								
Middle	970s								
	980s								
	990s								
	1000s								
	1010s								
	1020s								
	1030s								
Late	1040s								
	1050s								
	1060s								
	1070s								
	1080s								
	1090s								
	1100s								
1110s									
1120s									

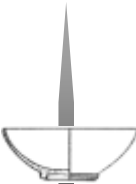
Timeline Table 12: Basin

Period	Type	Spittoon												
		A						B		C			D	
	AD													
Early	900s													
	910s													
	920s													
	930s													
	940s													
	950s													
	960s													
Middle	970s													
	980s													
	990s													
	1000s													
	1010s													
	1020s													
	1030s													
Late	1040s													
	1050s													
	1060s													
	1070s													
	1080s													
	1090s													
	1100s													
1110s														
1120s														

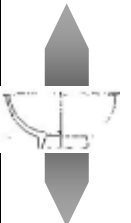

Timeline Table 13: Spittoon

Period	Type	Ring-foot bowl										
		Aa			Ab				Ba			
	AD											
Early	900s											
	910s											
	920s											
	930s											
	940s											
	950s											
	960s											
Middle	970s											
	980s											
	990s											
	1000s											
	1010s											
	1020s											
	1030s											
Late	1040s											
	1050s											
	1060s											
	1070s											
	1080s											
	1090s											
	1100s											
1110s												
1120s												

Timeline Table 15: Ring-foot bowl1

Period	Type	Ring-foot bowl													
		Bb			Ca				Cb		D		E		
	AD														
Early	900s														
	910s														
	920s														
	930s														
	940s														
	950s														
	960s														
Middle	970s														
	980s														
	990s														
	1000s														
	1010s														
	1020s														
	1030s														
	1040s														
	1050s														
Late	1060s														
	1070s														
	1080s														
	1090s														
	1100s														
	1110s														
	1120s														













Timeline Table 16: Ring-foot bowl2

Period	Type	Dragon-handled bowl	Flat-base bowl		Step-foot bowl			Flat-base dish			
			A	B				A	B	C	D
Early	AD										
	900s										
	910s										
	920s										
	930s										
	940s										
	950s										
960s											
Middle	970s										
	980s										
	990s										
	1000s										
	1010s										
	1020s										
Late	1030s										
	1040s										
	1050s										
	1060s										
	1070s										
1080s											
1090s											
1100s											
1110s											
1120s											
											









Timeline Table 17: Dragon-handled bowl , Flat-base bowl , Step-foot bowl , Flat-base dish1

Period	Type	Ring-foot dish											
		Aa			Ab			Ba			Bb		
	AD												
Early	900s												
	910s												
	920s												
	930s												
	940s												
	950s												
	960s												
Middle	970s												
	980s												
	990s												
	1000s												
	1010s												
	1020s												
	1030s												
Late	1040s												
	1050s												
	1060s												
	1070s												
	1080s												
	1090s												
	1100s												
1110s													
1120s													

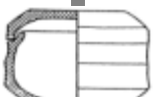
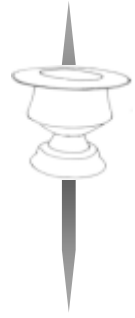
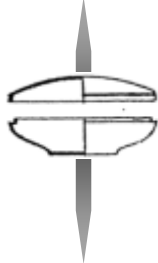
Timeline Table 18: Ring-foot dish

Period	Type	Oblong-lo bed dish	Inkstone and brush-washer			Ocarina			Pillow			
			A	B	C	A	B	C	A	B	C	D
	AD											
Early	900s											
	910s											
	920s											
	930s											
	940s											
	950s											
	960s											
Middle	970s											
	980s											
	990s											
	1000s											
	1010s											
	1020s											
	1030s											
Late	1040s											
	1050s											
	1060s											
	1070s											
	1080s											
	1090s											
	1100s											
1110s												
1120s												

Timeline Table 19: Oblong-lobed dish, Inkstone and brush-washer, Ocarina, Pillow

Period	Type	Box				Lamp and Incense burner			
		A	Ba	Bb	Bc	A	Ba	Bb	C
	AD								
Early	900s								
	910s								
	920s								
	930s								
	940s								
	950s								
	960s								
Middle	970s								
	980s								
	990s								
	1000s								
	1010s								
	1020s								
	1030s								
Late	1040s								
	1050s								
	1060s								
	1070s								
	1080s								
	1090s								
	1100s								
1110s									
1120s									

Timeline Table 20: Box & Lamp and Incense burner

CHARTS

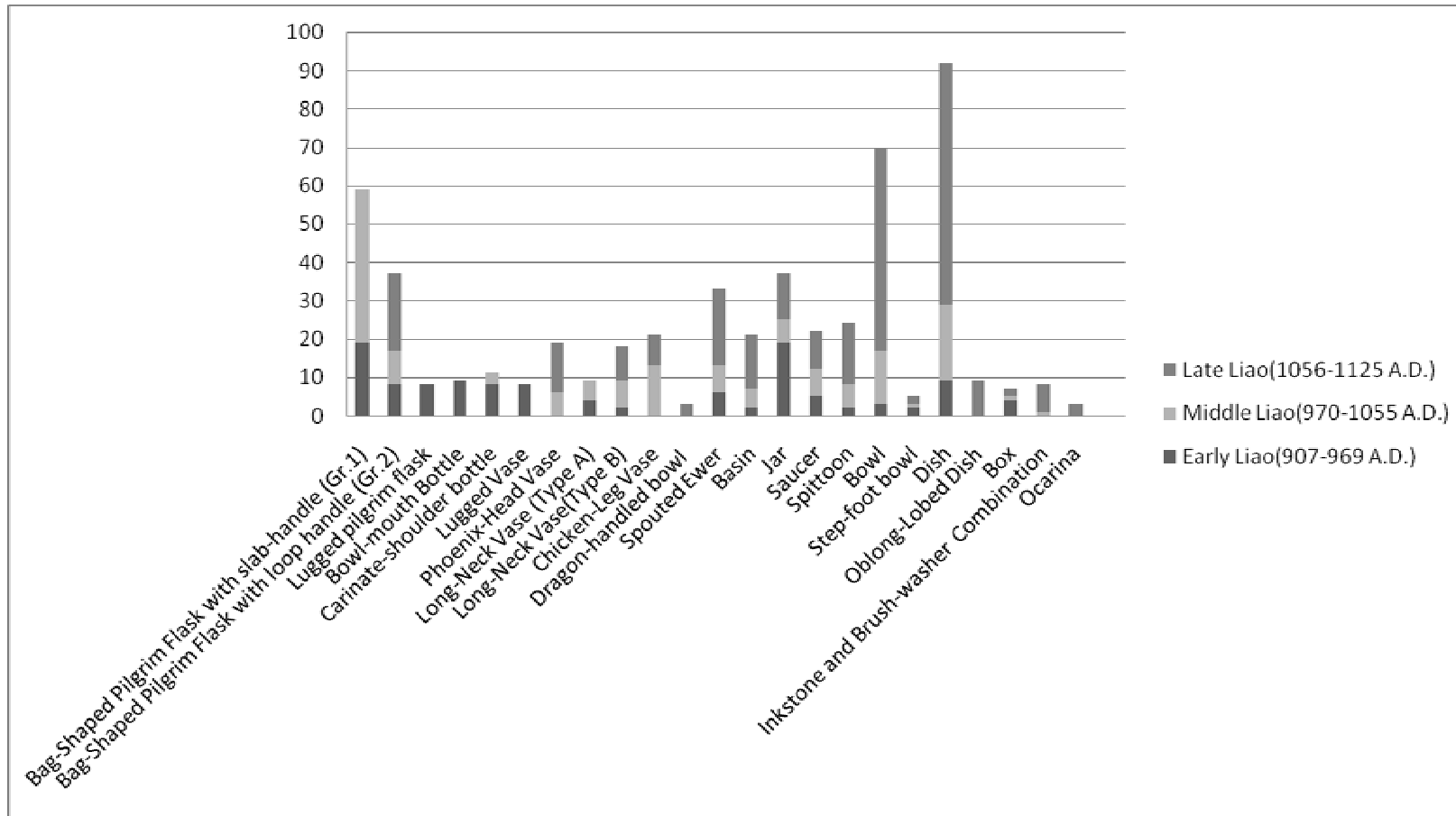

Chart 1: Quantity analysis of different ceramic shapes of Liao dynasty

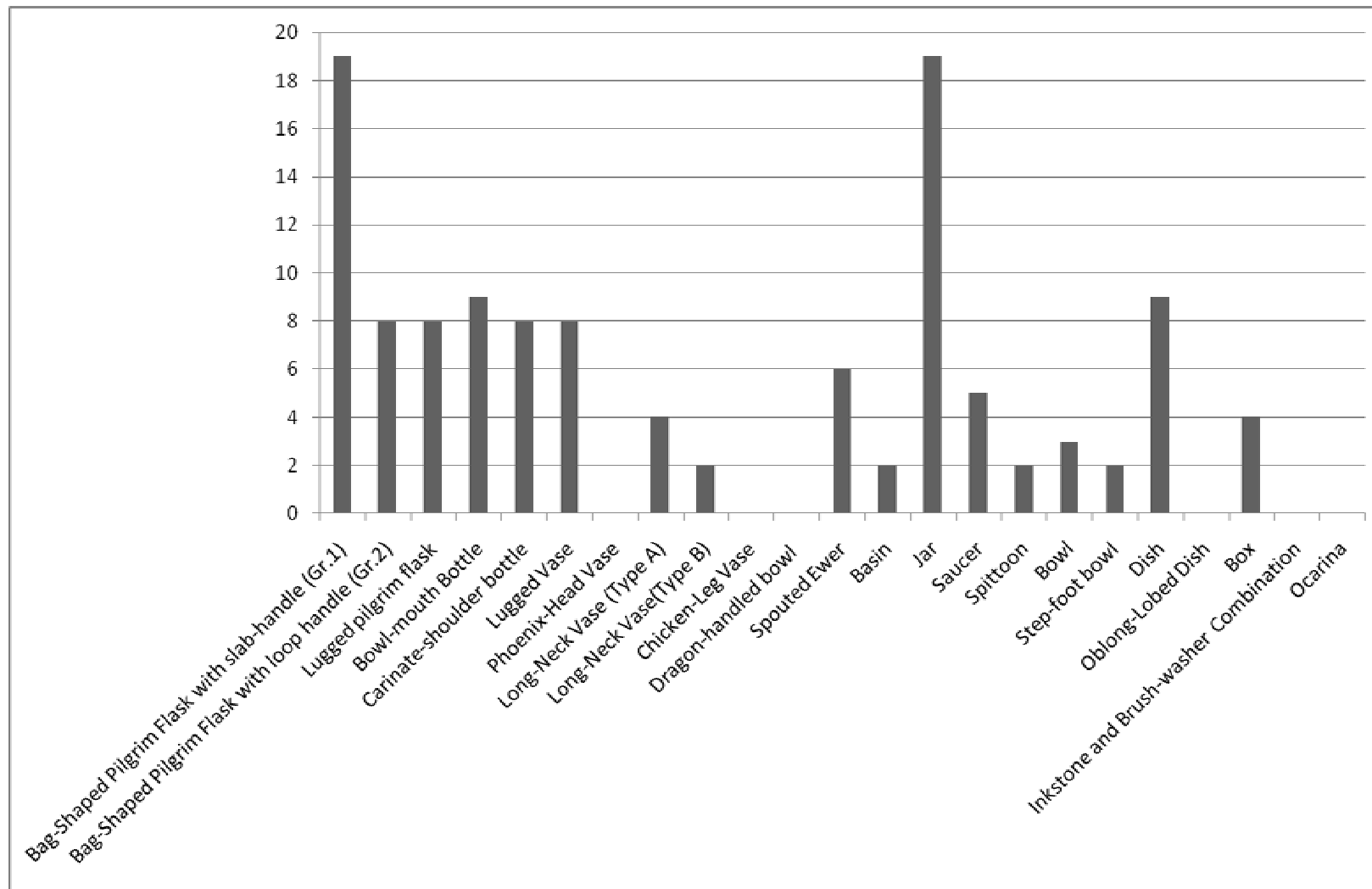

Chart 2: Quantity analysis of different ceramic shapes in Early Liao dynasty

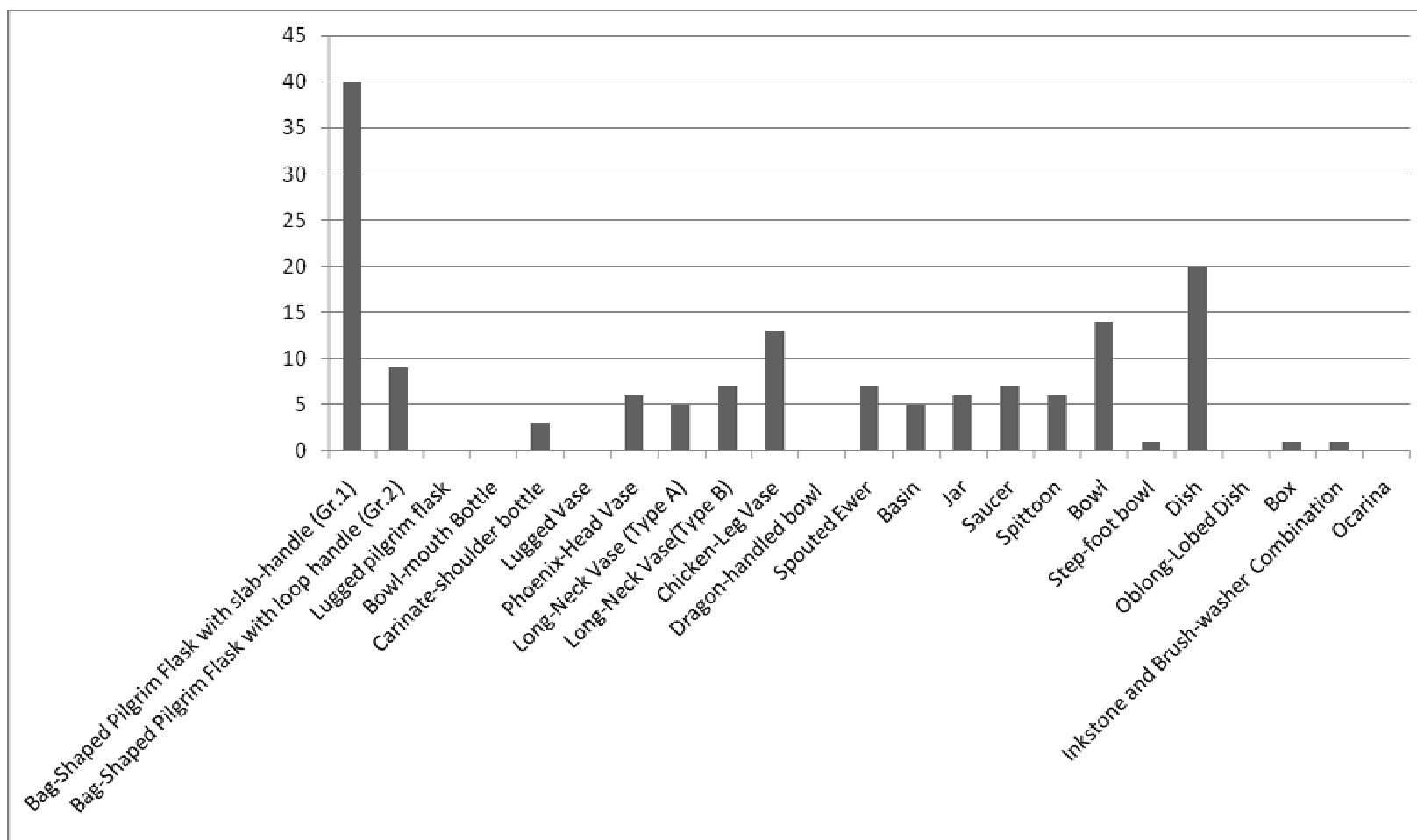

Chart 3: Quantity analysis of different ceramic shapes in Middle Liao dynasty

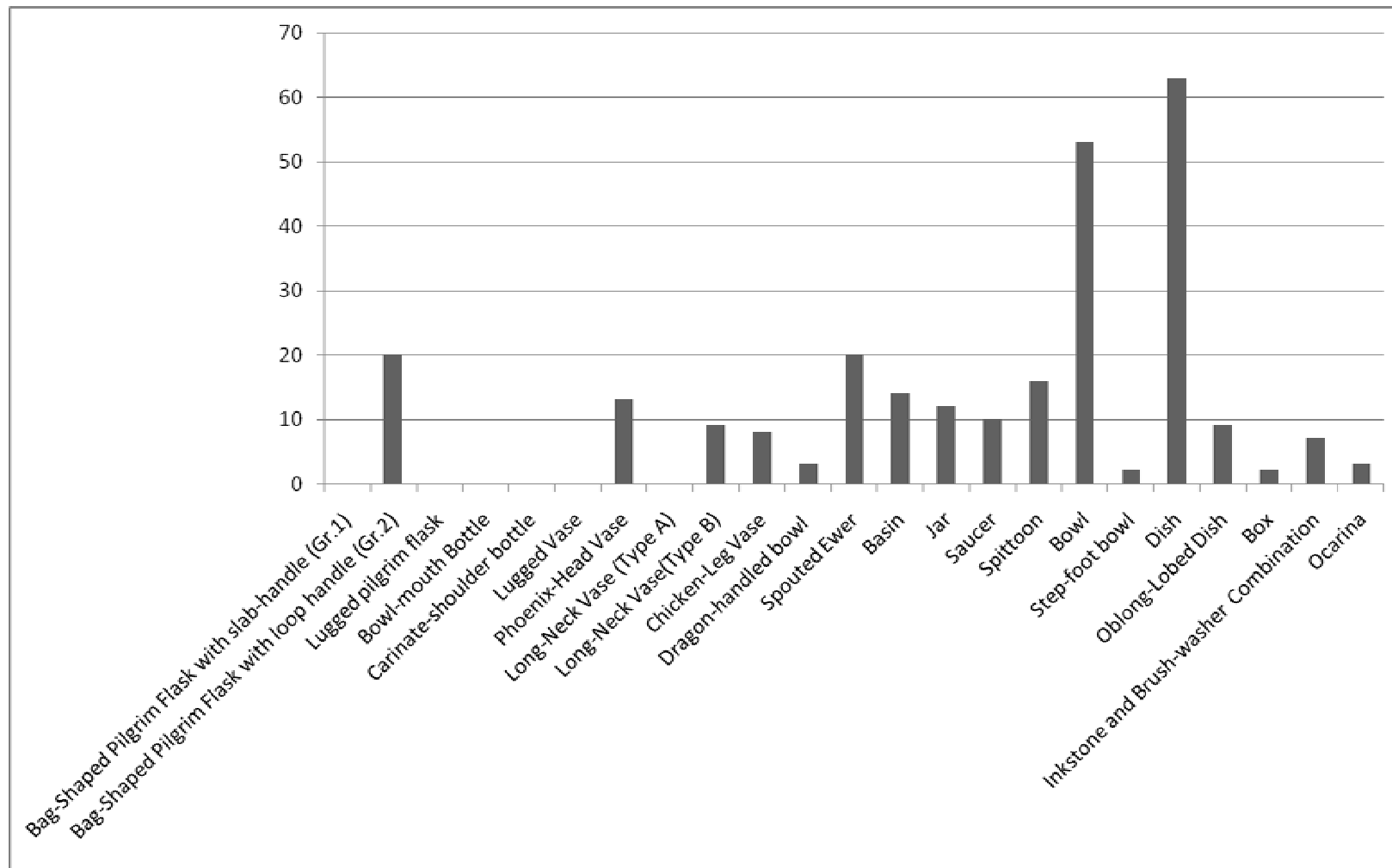

Chart 4: Quantity analysis of different ceramic shapes in Late Liao dynasty

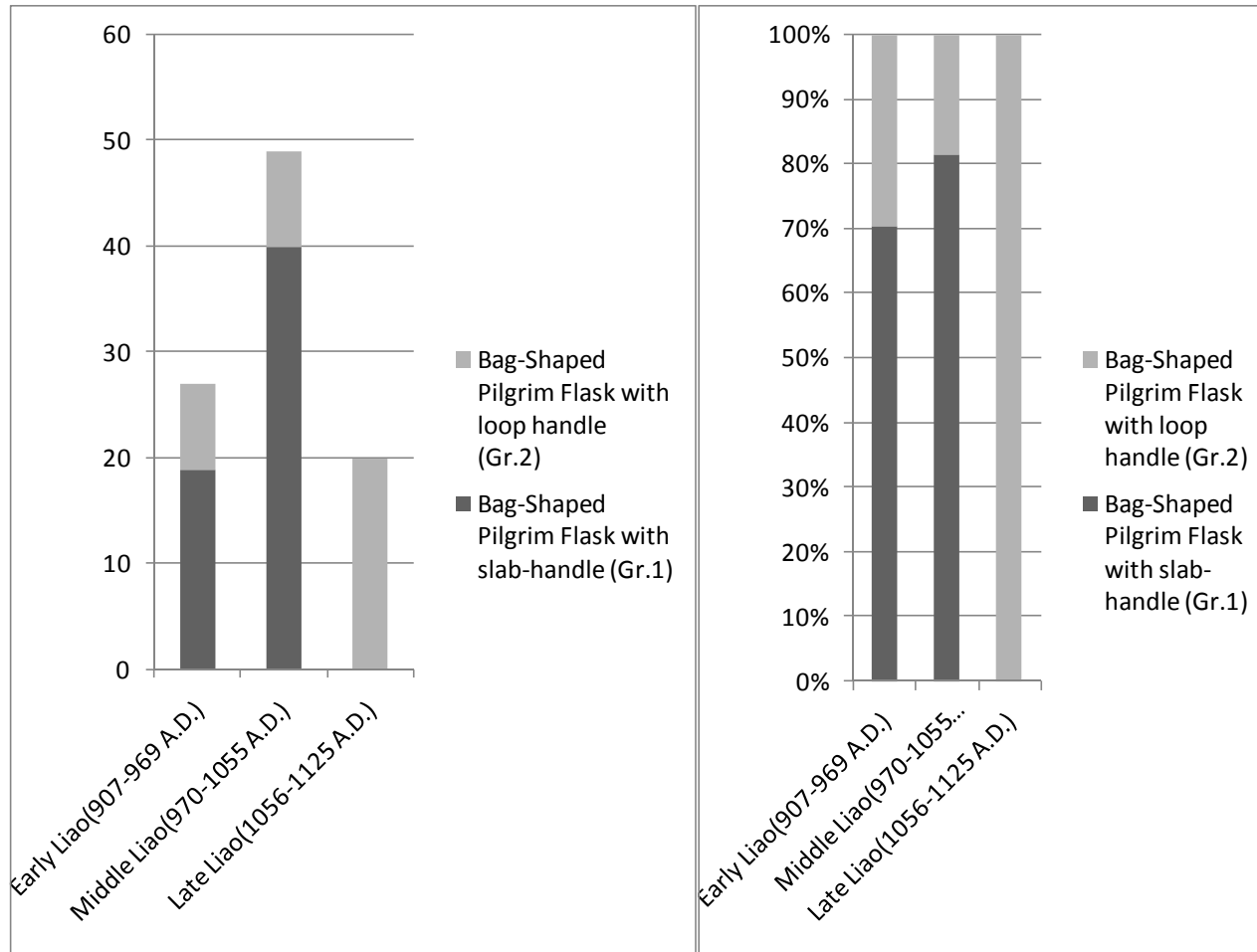

Chart 5: Case analysis on bag-shaped pilgrim flask

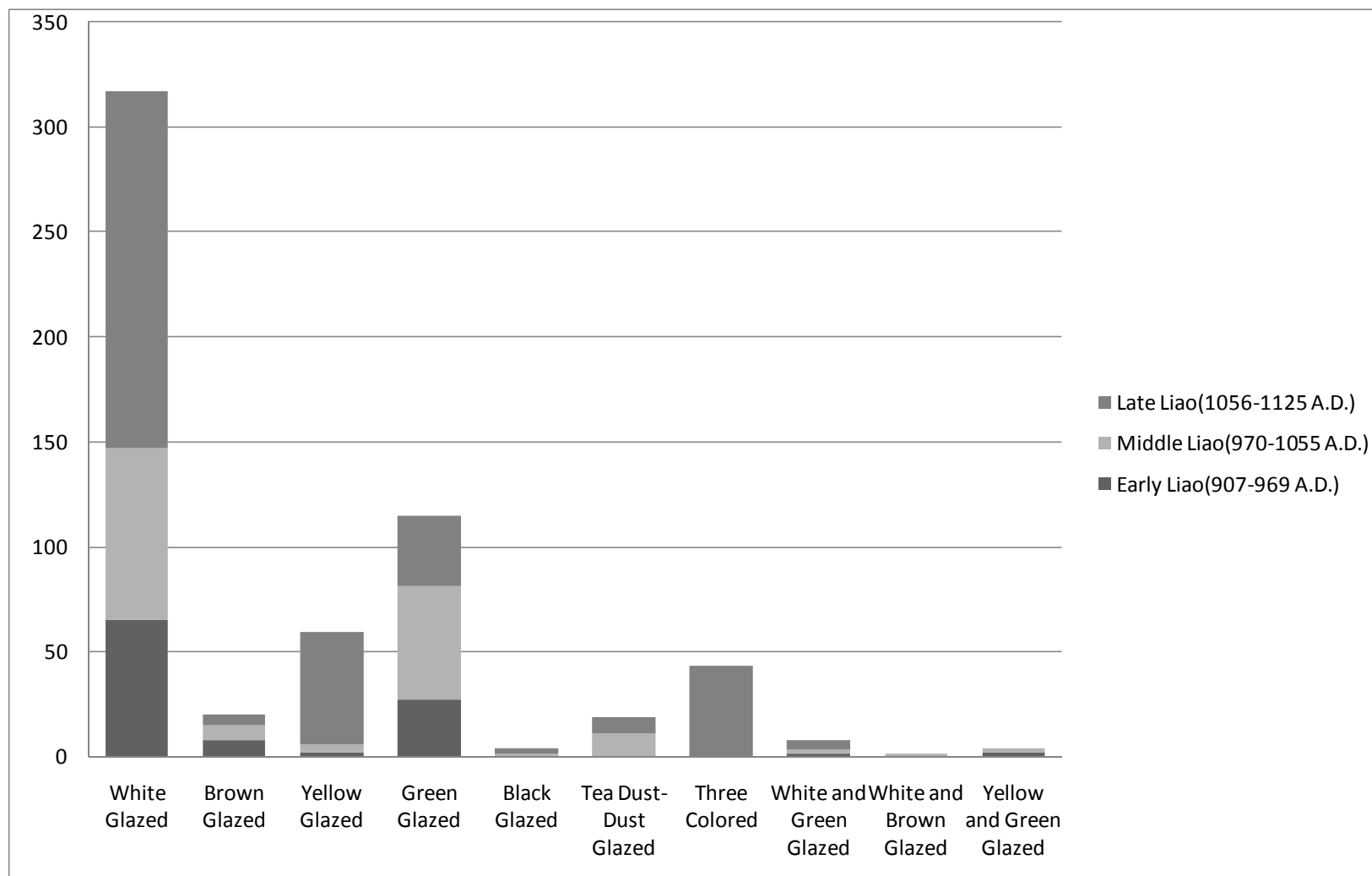

Chart 6: Quantity analysis of different glazes in Liao dynasty

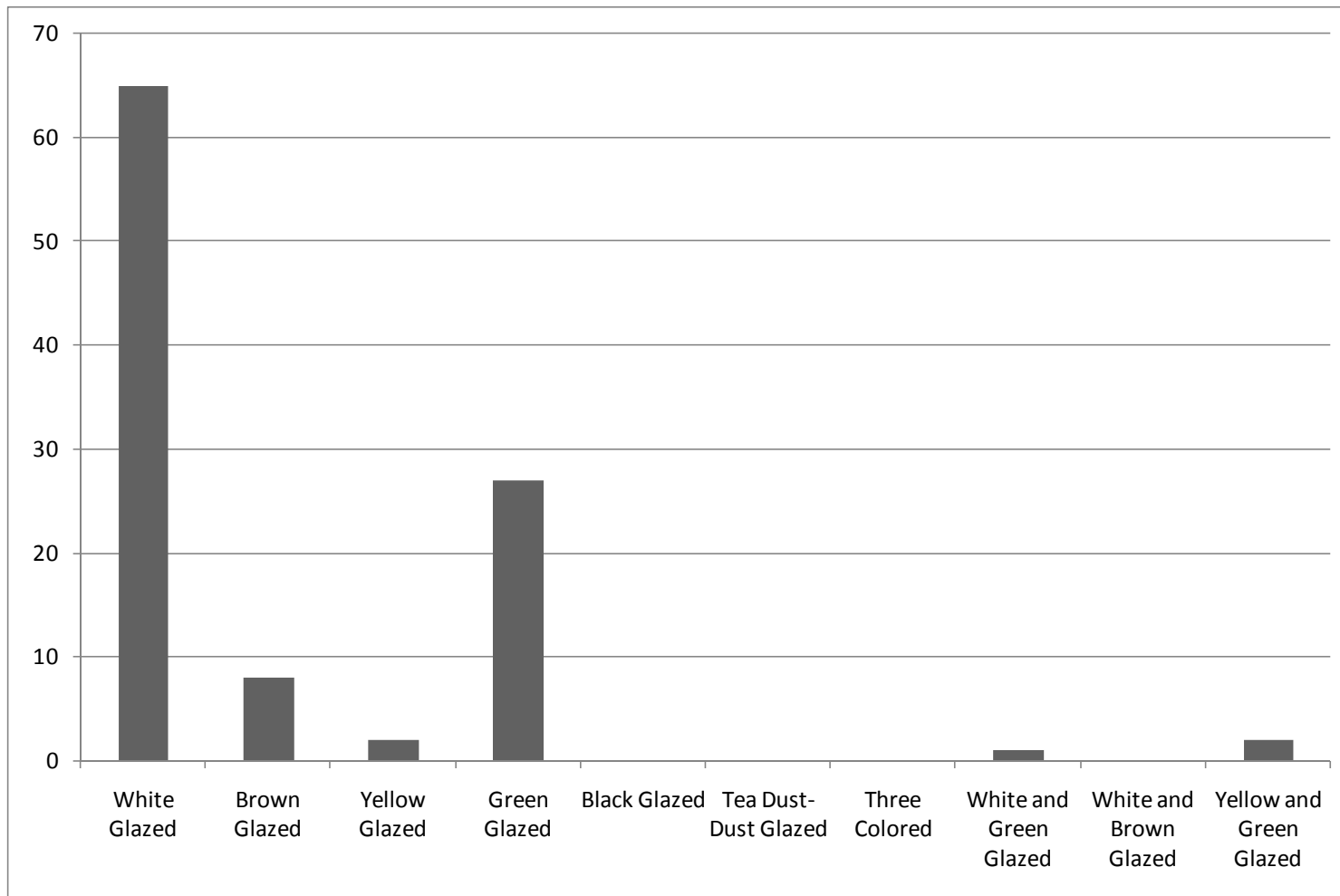

Chart 7: Quantity analysis of different glazes in Early Liao dynasty

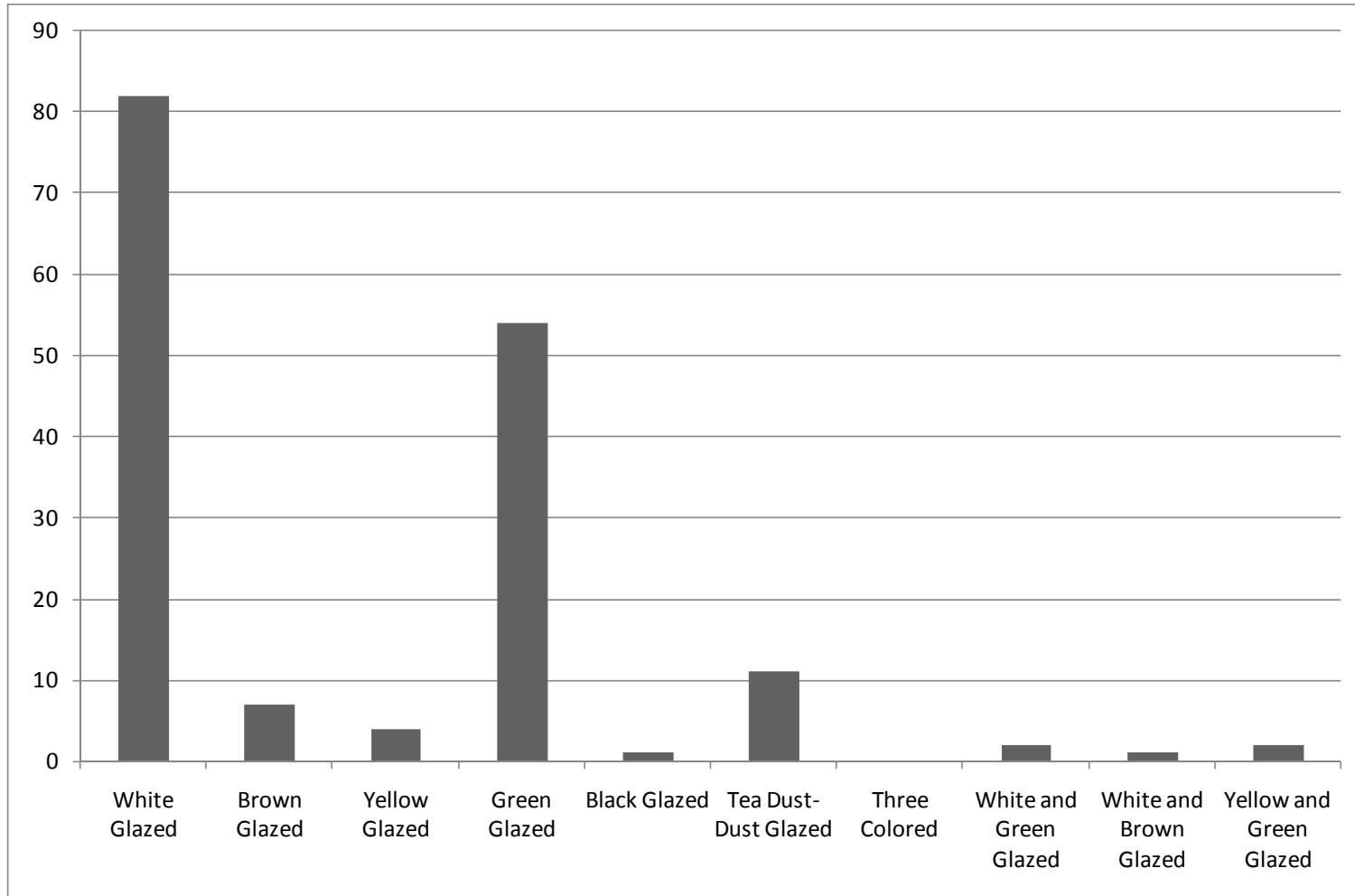

Chart 8: Quantity analysis of different glazes in Middle Liao dynasty

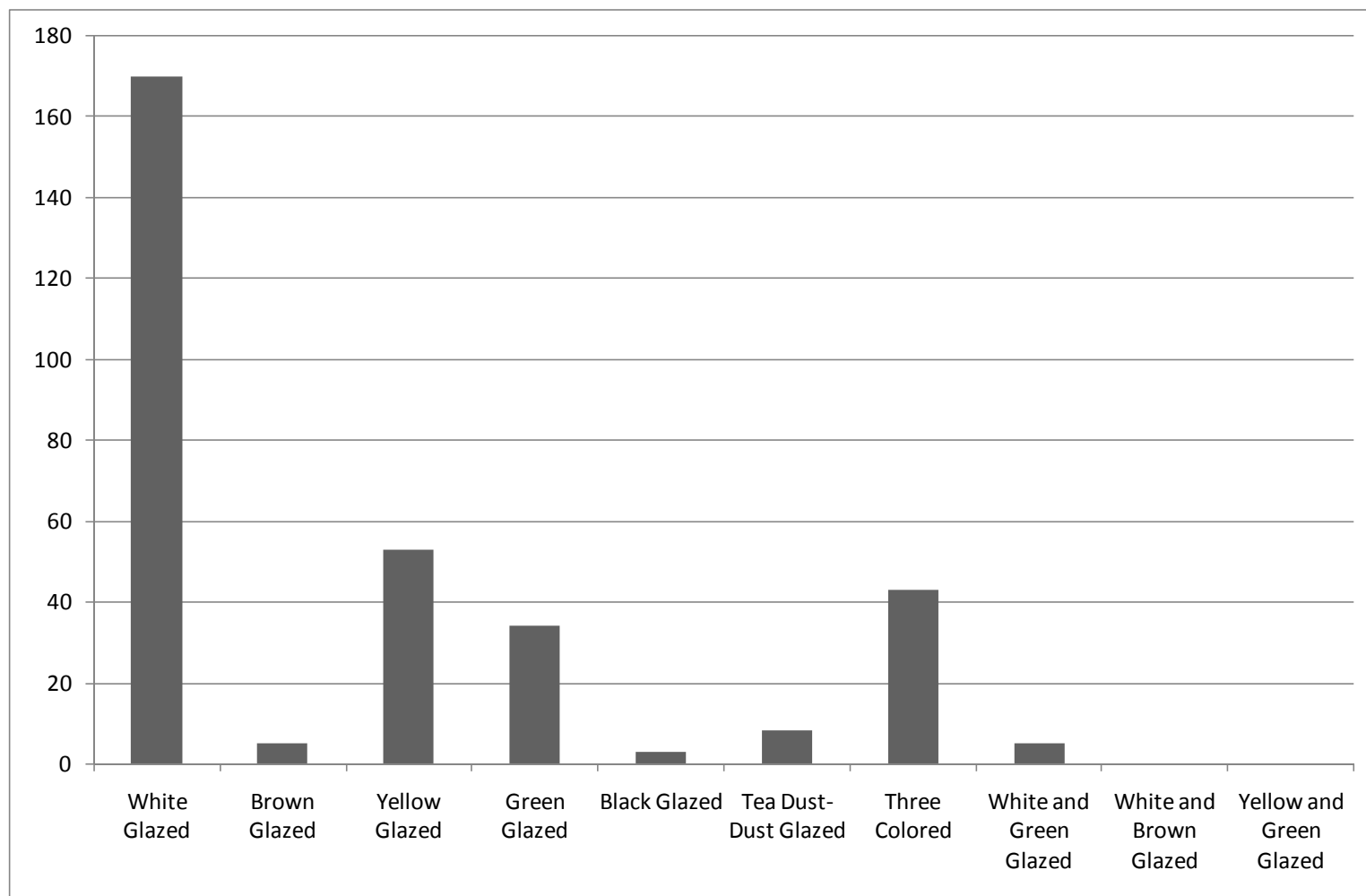

Chart 9: Quantity analysis of different glazes in late Liao dynasty

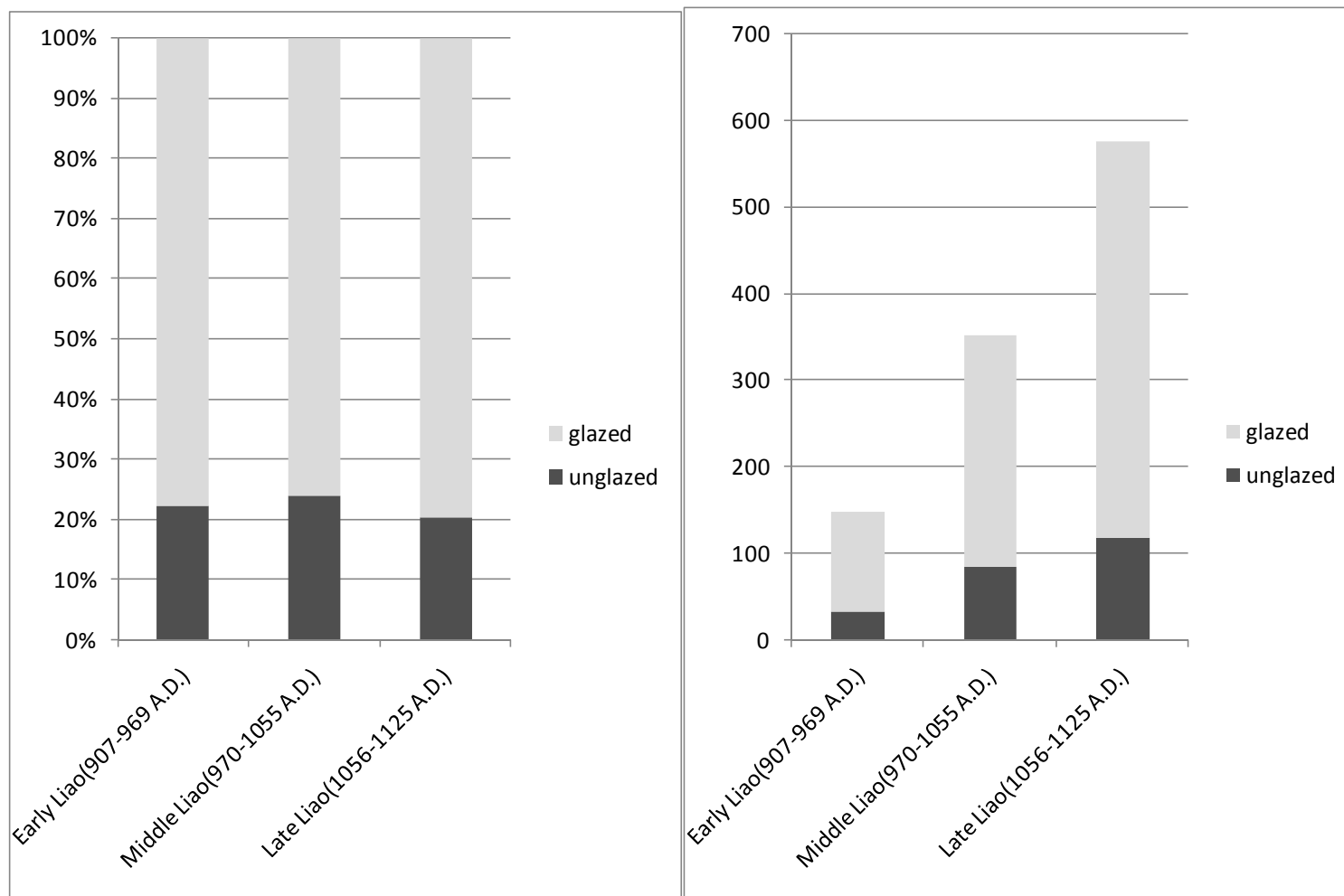

Chart 10: Quantity comparison of unglazed and glazed Liao ceramics

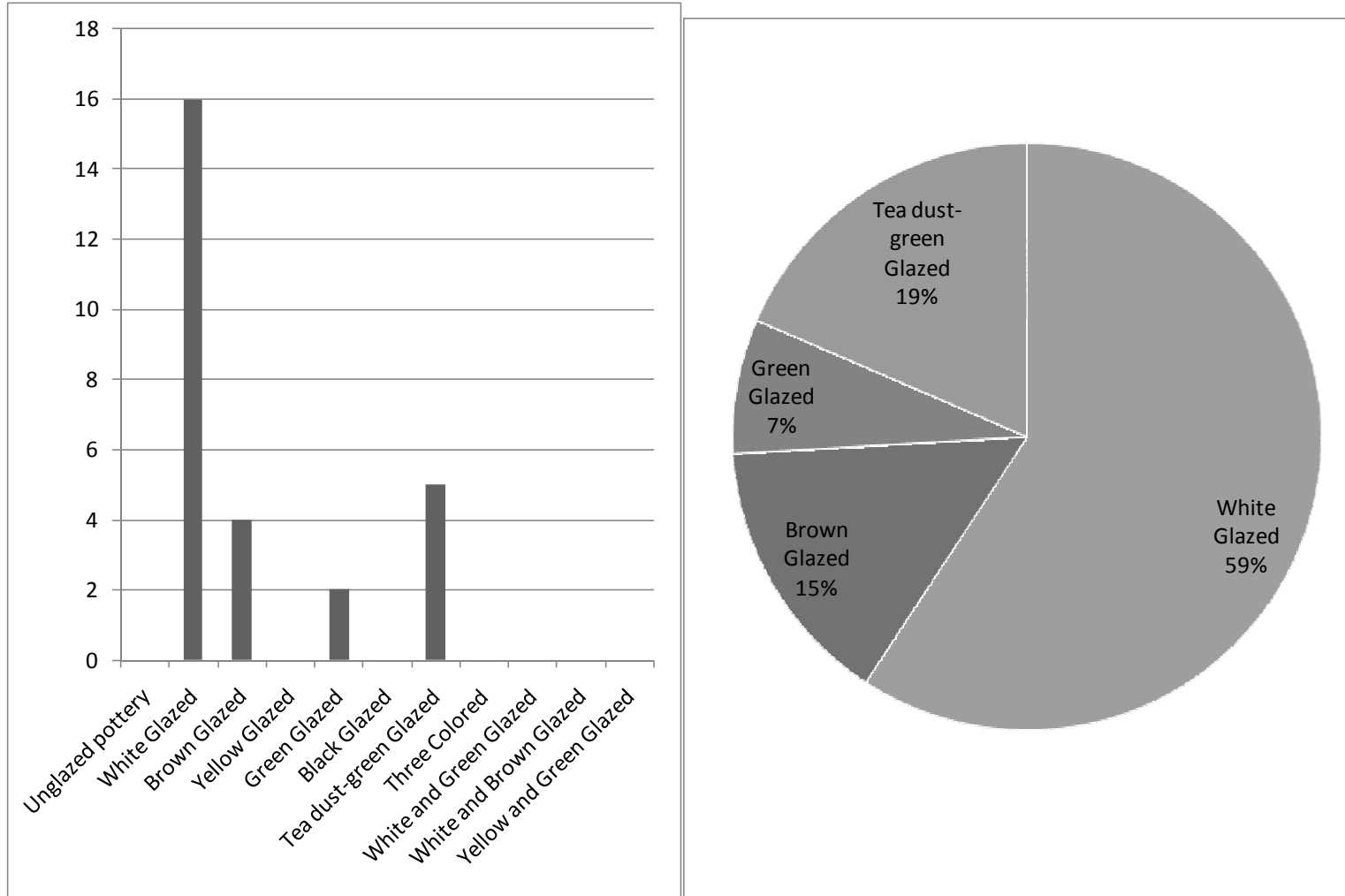

Chart 11: Quantity analysis of glaze varieties of Liao ceramics in the upper class of Khitan people

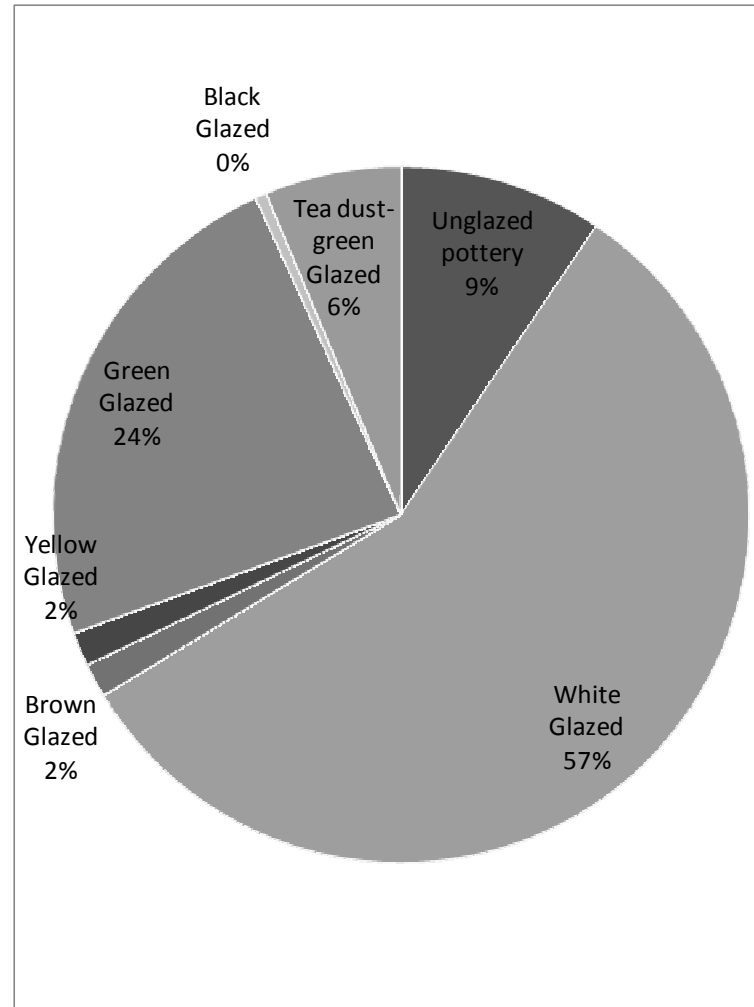
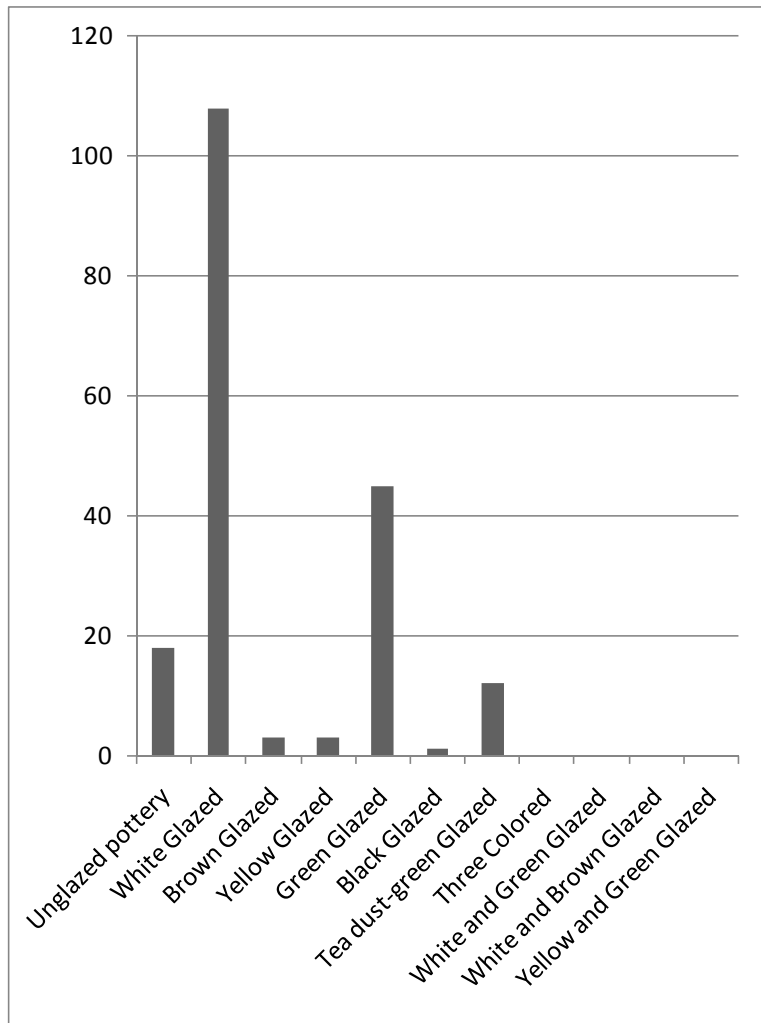

Chart 12: Quantity analysis of glaze varieties of Liao ceramics in the middle class of Khitan people

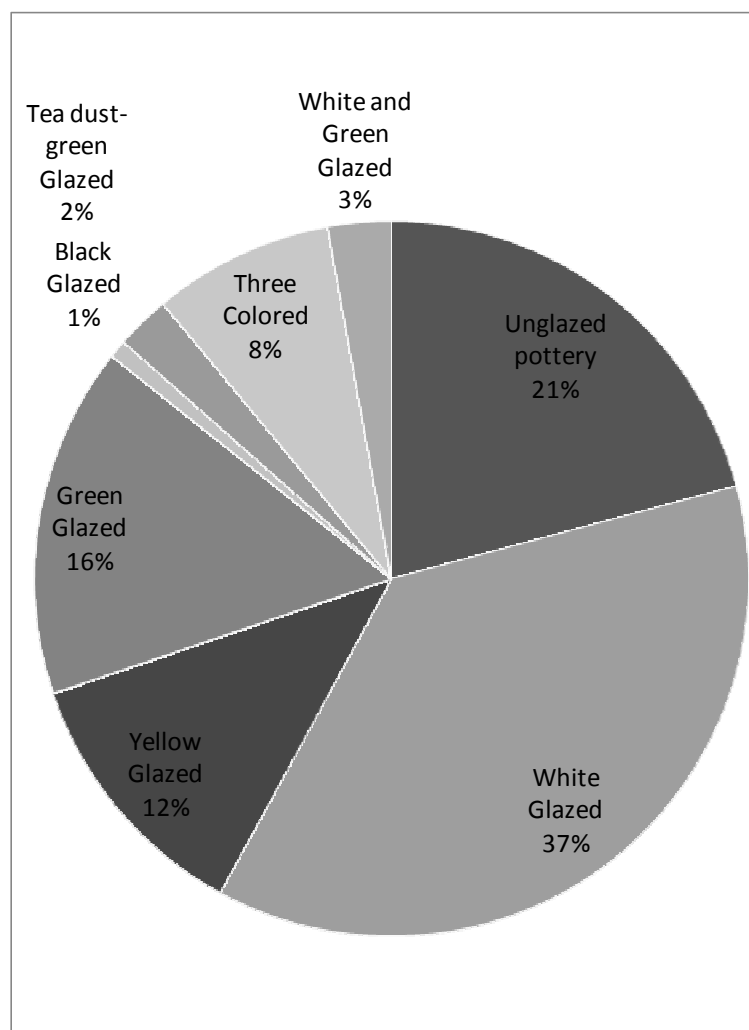
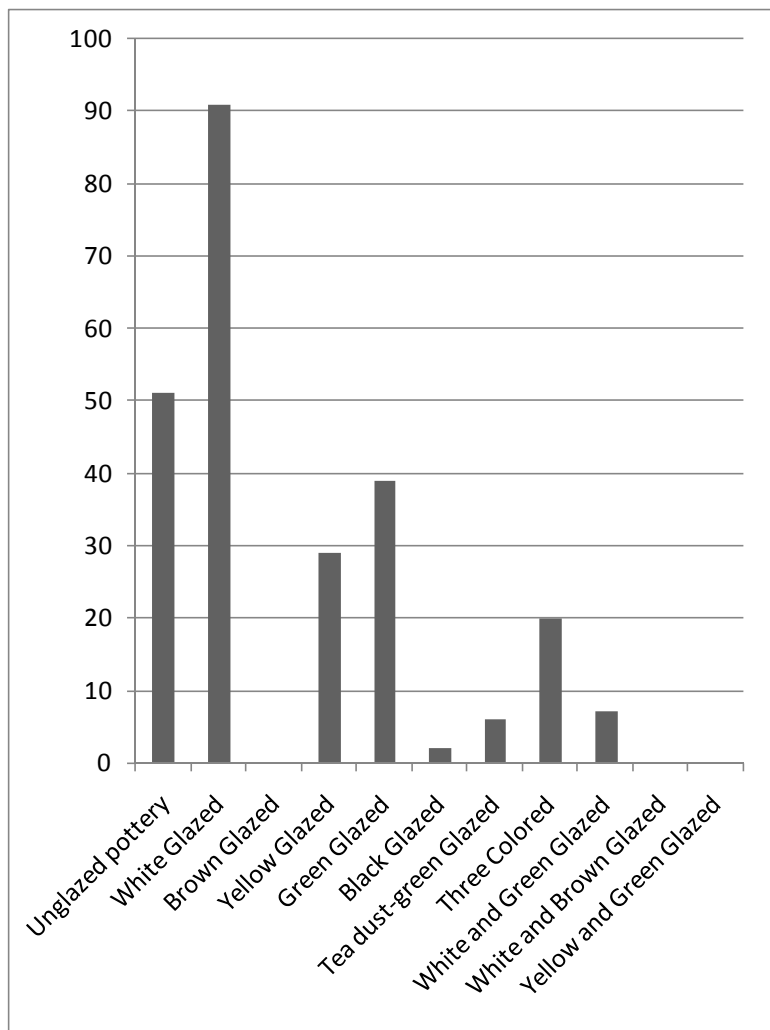

Chart 13: Quantity analysis of glaze varieties of Liao ceramics in the lower class of Khitan people

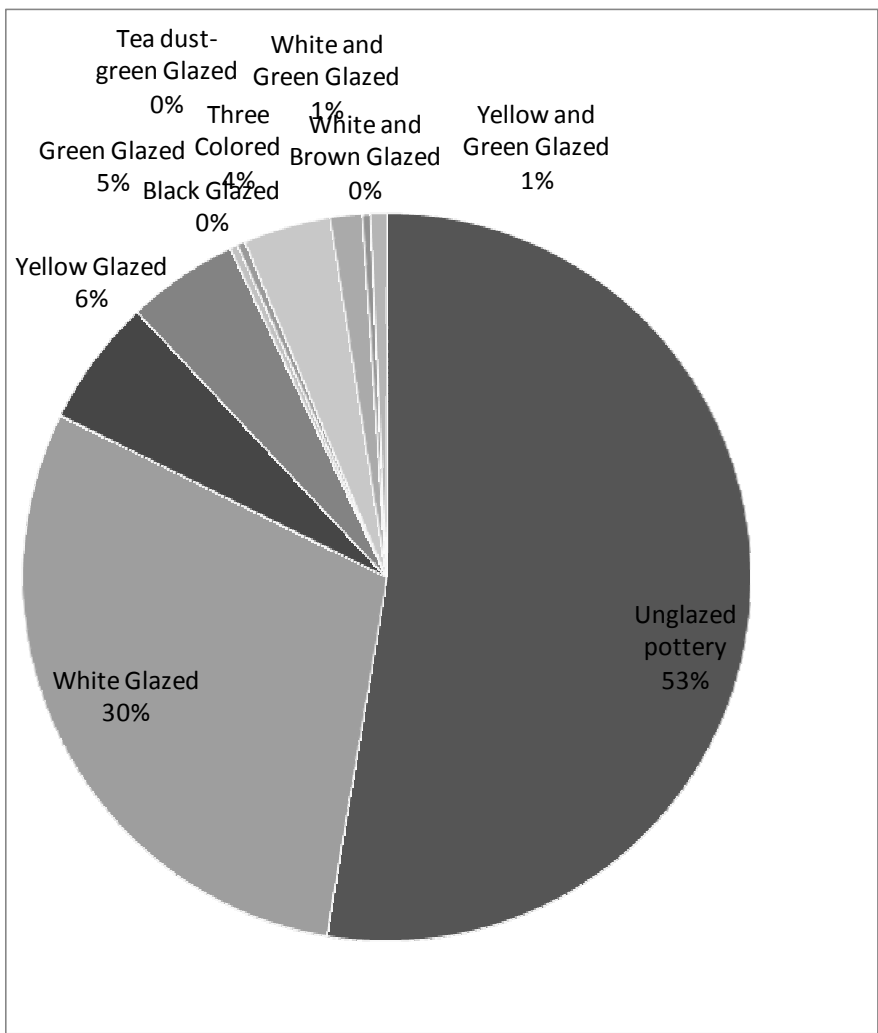
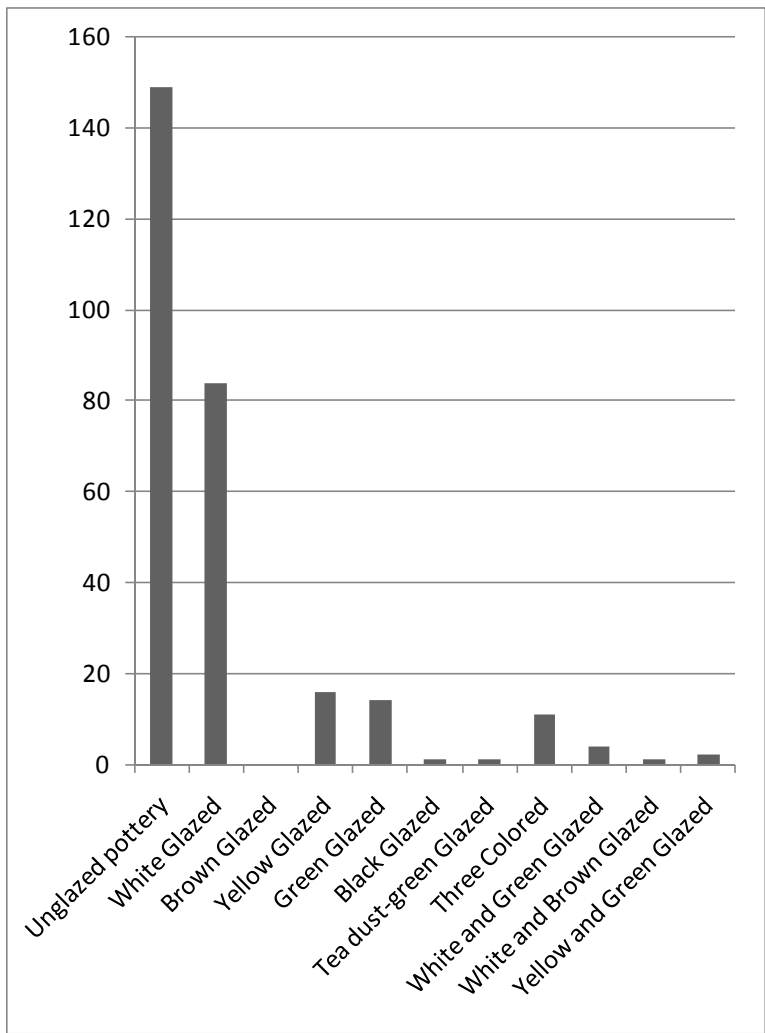

Chart 14: Quantity analysis of glaze varieties of Liao ceramics in Han people