

CLAVICHORDE
IN
SÜDDEUTSCHEN SAMMLUNGEN
Band II

Sabine Katharina Klaus

CLAVICHORDE
IN
SÜDDEUTSCHEN SAMMLUNGEN

Zweiter Band
(Bildteil)

Magisterarbeit
im Fach Musikwissenschaft
an der Fakultät für Kulturwissenschaften
der Eberhard-Karls-Universität Tübingen

vorgelegt von
Sabine Katharina Klaus
aus
Reutlingen

Sommersemester 1989

INHALT

	Blatt
Vorbemerkungen	II
Symbole der Resonanzraum-Skizzen	II
I. Zeichnungen	III
II. Grundriß-Skizzen	XXVI
III. Mensurkurven	XXXVII
IV. Fotografien	IL
Übersicht des Bildteils	LXXIV





VORBEMERKUNGEN

Die nachfolgenden Zeichnungen und Grundriß-Skizzen der Clavi-chorde sollen die Beschreibungen der Instrumente verdeutlichen und ergänzen, da trotz aller Bemühung um Verständlichkeit die verbale Beschreibung ohne Veranschaulichung teilweise nur schwer nachzuvollziehen ist, oder unverständlich bleibt. Es wird daher von der gleichzeitigen Benutzung von Katalogtext und Zeichnungen, Skizzen und Fotografien ausgegangen. Verweise im Katalogtext kennzeichnen jeweils die Existenz einer veranschaulichenden Abbildung.

Um den Vergleich gleichartiger Teile verschiedener Instrumente zu gewährleisten, besitzen sie stets denselben Maßstab. So wurden die Querschnitte der Stege und Waagebalken, sowie alle Zeichnungen der Tasten im Maßstab 1:1, die Skizzen des Resonanzraumes im Maßstab 1:5 wiedergegeben.

Für das Überlassen bzw. das Erstellen der nicht gekennzeichneten Fotografien der Instrumente des Deutschen Museums und des Musikinstrumentenmuseums im Münchner Stadtmuseum danke ich Herrn Fritz Thomas und Herrn Martin Kares.

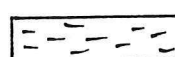
SYMBOLE DER RESONANZRAUM-SKIZZEN

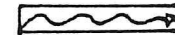
- | | |
|---|---|
|  | Seitenwände |
|  | Teile, die den Raum zwischen Resonanzboden und Unterboden ausfüllen. |
|  | Teile, die über den Resonanzboden hinausragen. |
|  | Am Unterboden befindliche Stabilisierungsleisten, die nicht bis zum Resonanzboden reichen. |
|  | Am Resonanzboden befindliche Rippen oder Resonanzbodenauflegeleisten, die nicht bis zum Unterboden reichen. |
|  | Stege |
|  | Stützstreben, die schräg vom Unterboden nach oben in Richtung Resonanzboden verlaufen. |

I. ZEICHNUNGEN

DEUTSCHES MUSEUM, MÜNCHEN

INV.NR.18165

Gebundenes Clavichord

deutsch, 2. Hälfte 17. Jahrhundert

1. Oberes Dammfenster:

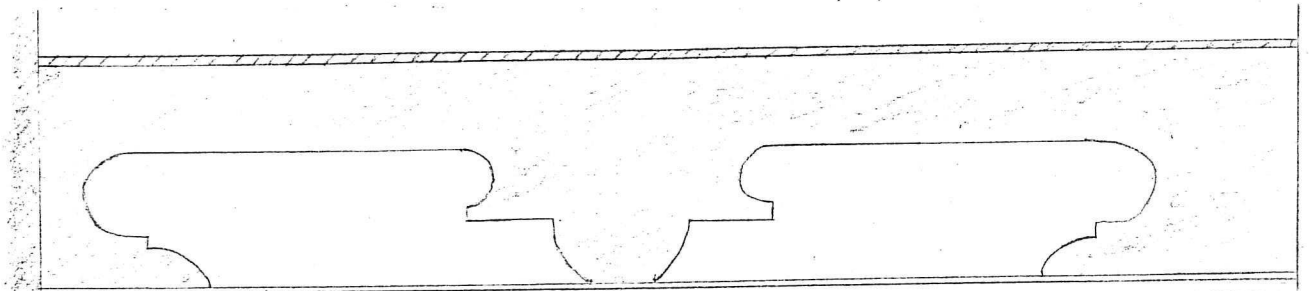

2. Resonanzraum: (Skizze nach dem im Museum befindlichen Plan)

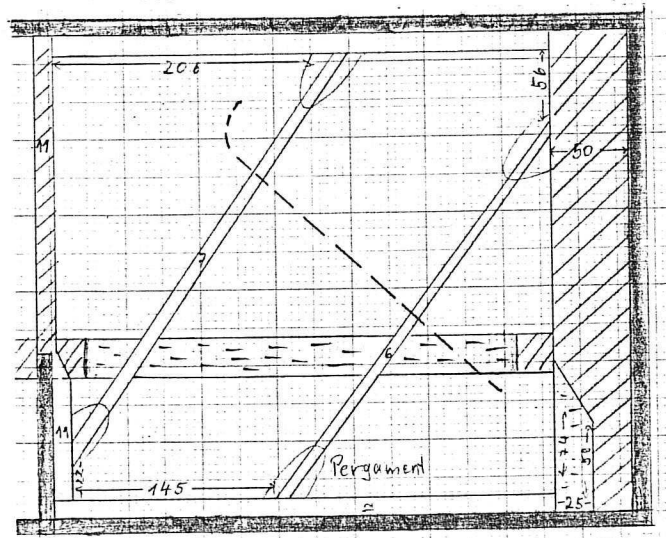

3. Untertastenbelag:

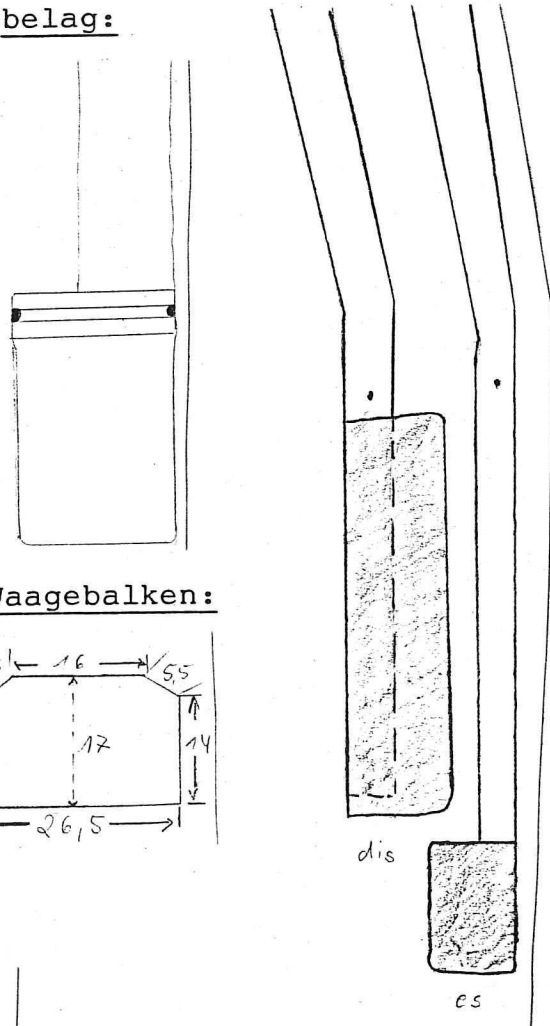

4. Steg:

Baß:

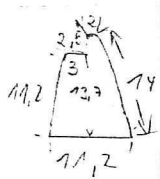

Diskant:

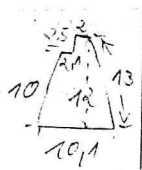

5. Waagebalken:

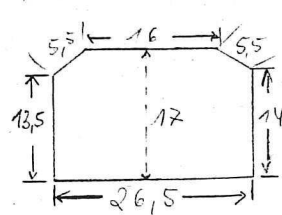

6. Untertaste:

(Seitenansicht)

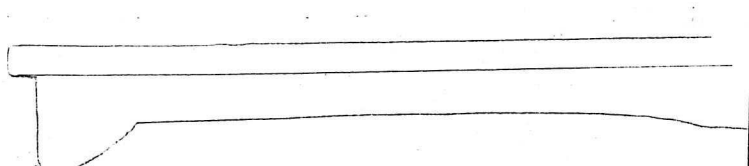

7. gebrochene Obertasten:

INV.NR.5392

Gebundenes Clavichord

Johann Weiss, Stuttgart 1702

1. Steg:

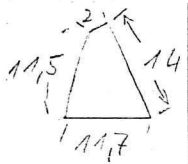

Stegende:

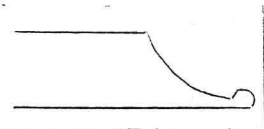

3. Waagebalken:

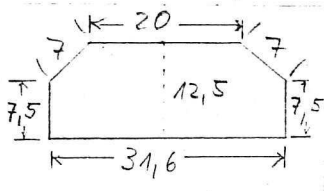

4. Stirnflächenbelag:

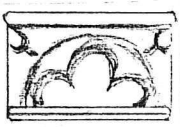

5. Untertaste:

(Seitenansicht)

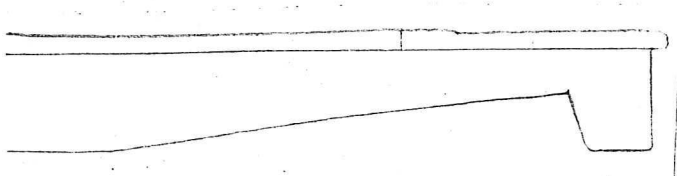

2. Tastenhebelhinterenden:

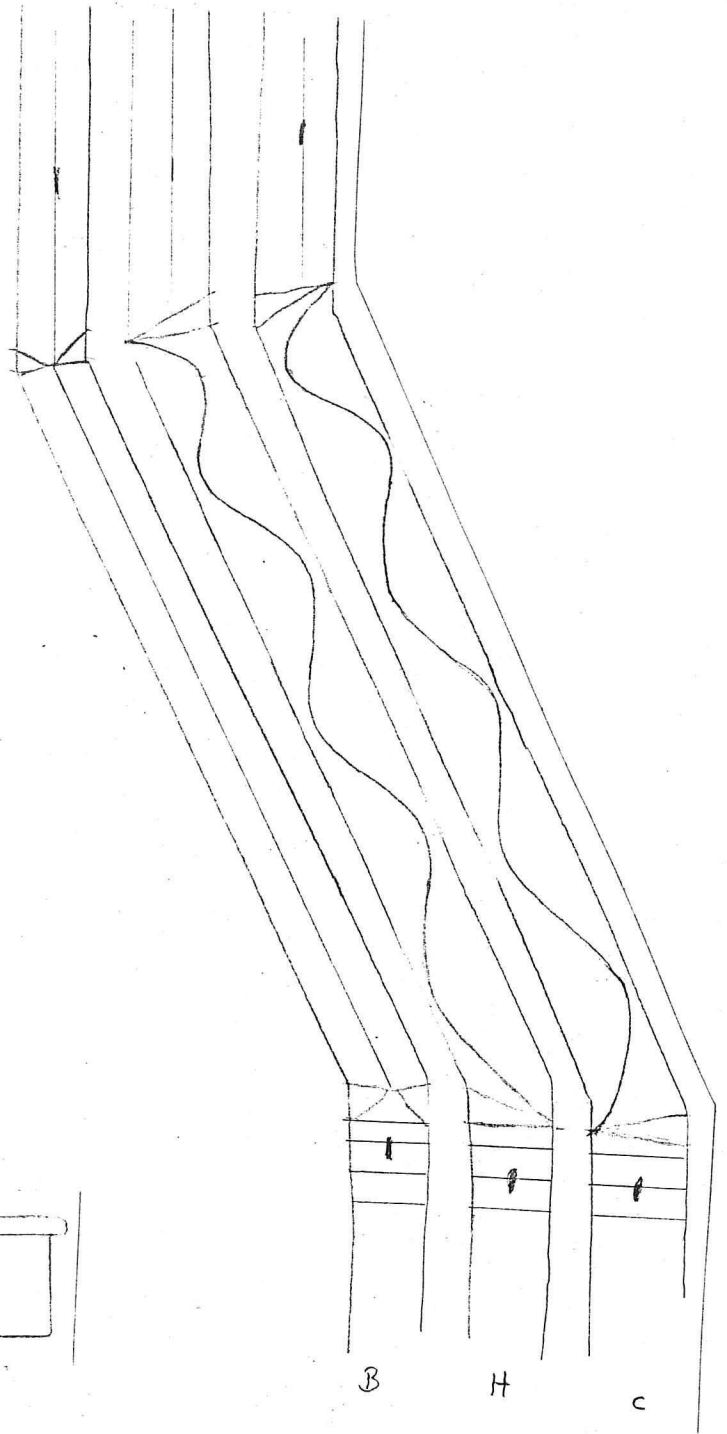

INV.NR.16816

Gebundenes Clavichord

Franciscus König, Ingolstadt 1739

1. Resonanzraum:

(Rippen nicht original)

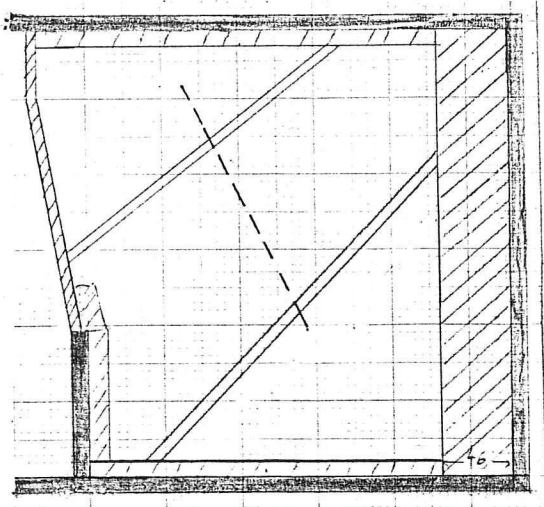

2. Anhängestock:

(Querschnitt)

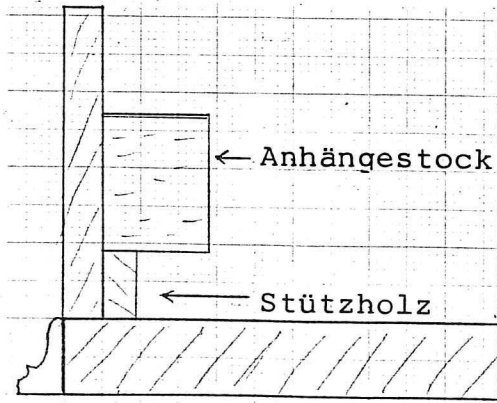

3. Untertaste:

(Seitenansicht)

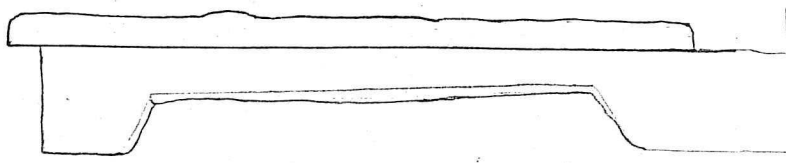

4. Steg:

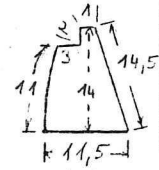

Stegende:

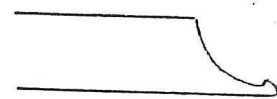

5. Waagebalken:

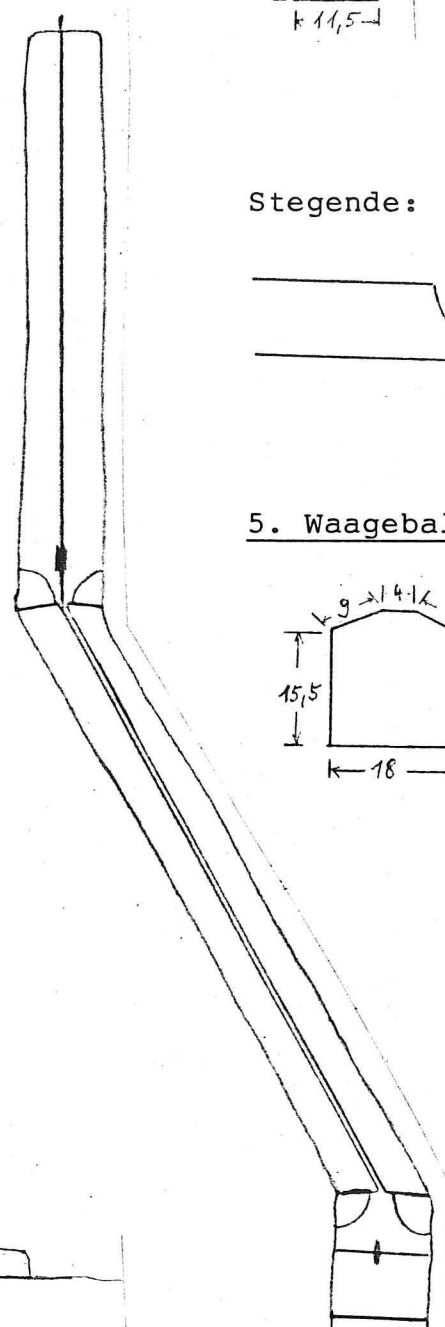
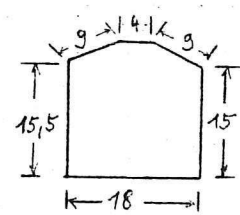

6. Tastenhebelhinterende:

INV.NR.20780

Gebundenes Clavichord

C.W.Lemme, Braunschweig 1766

1. Resonanzraum: (Skizze nach dem bei der Restaurierung angefertigten Foto)

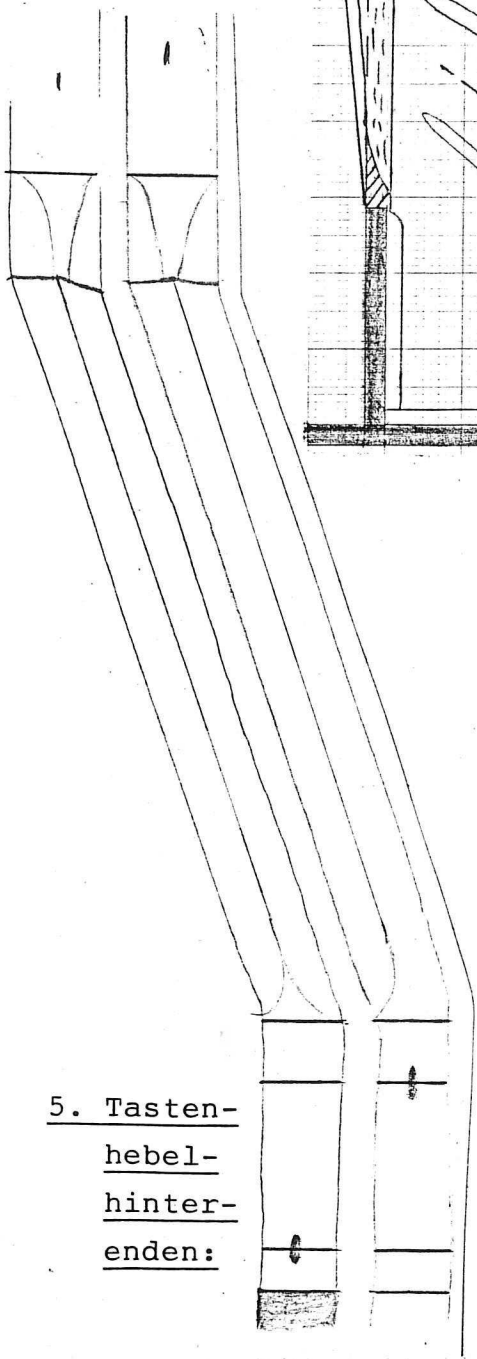
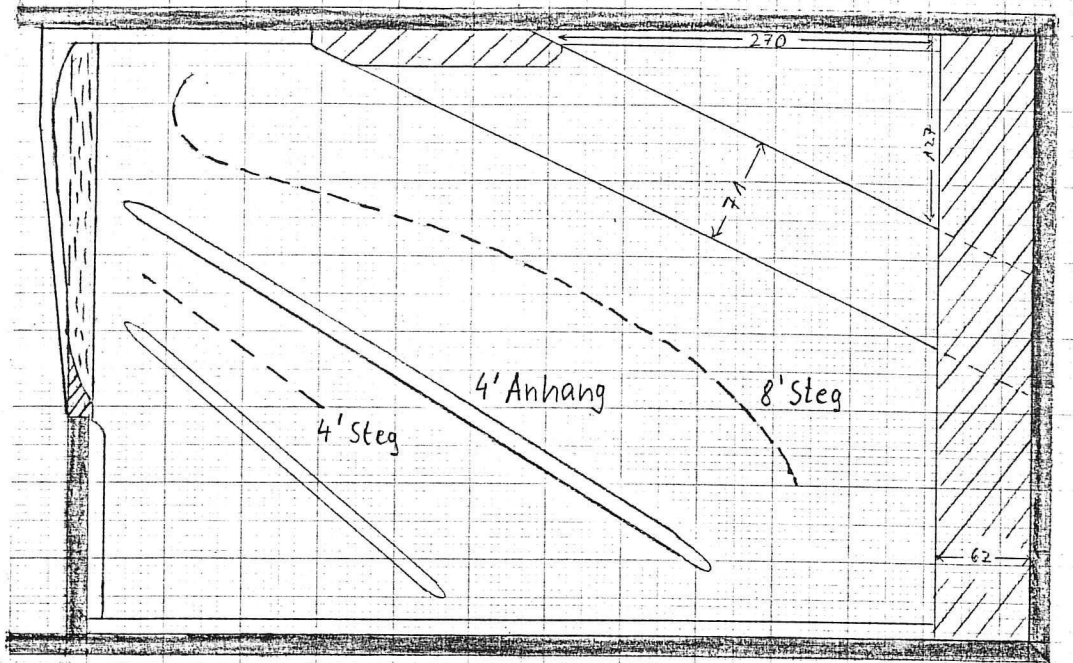

2. Stege:

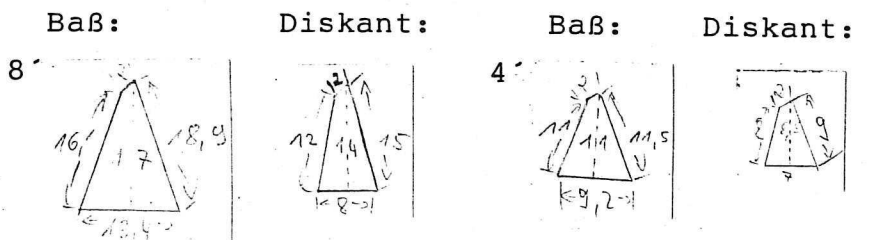

3. Untertaste: (Seitenansicht)

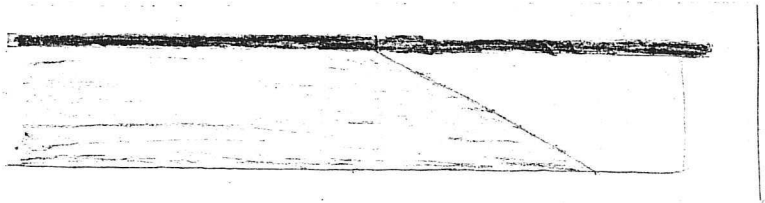

4. Obertaste: (Seitenansicht)

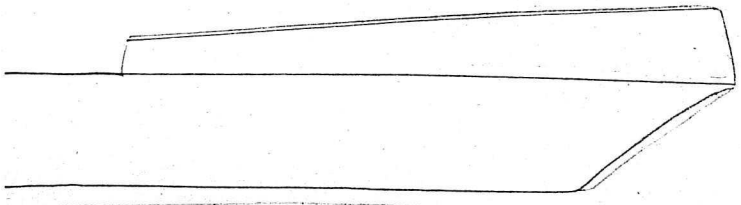

5. Tasten-
hebel-
hinter-
enden:

INV.NR.5385

Gebundenes Clavichord

Christian Gottlob Hubert, Ansbach 1782

1. Resonanzraum: (Skizze nach dem im Museum befindlichen Plan)

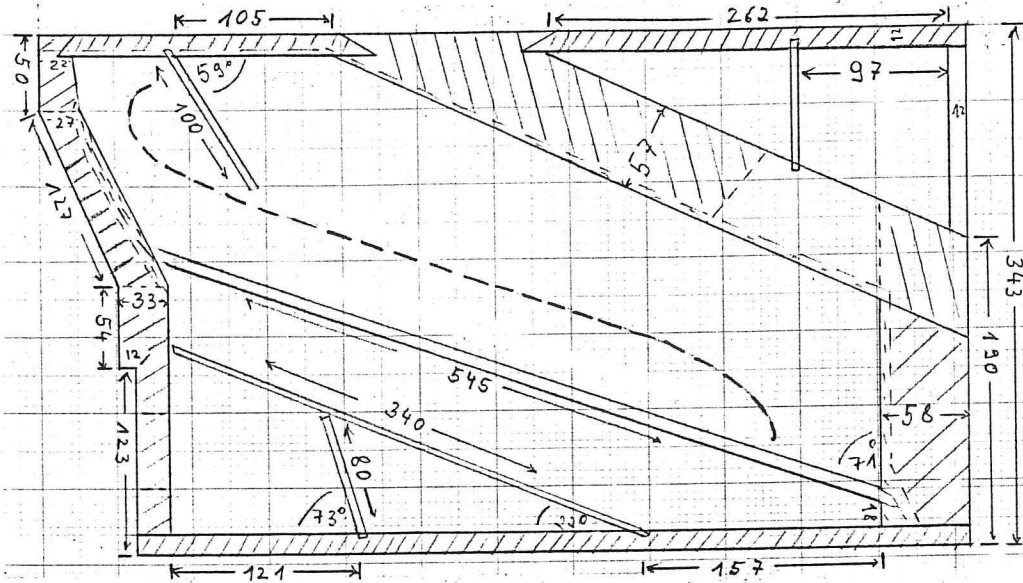

(ohne
Außen-
wände)

2. Untertaste: (Seitenansicht)

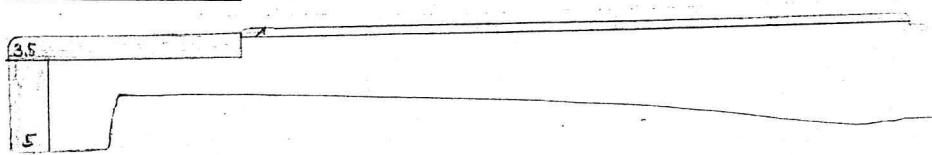

3. Obertaste: (Seitenansicht)

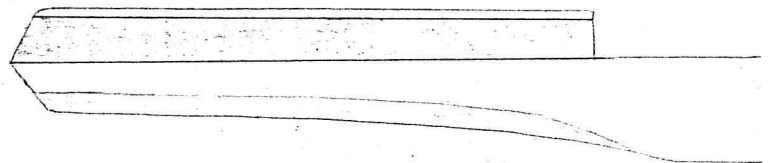

4. Tastenhebel-
hinterenden:

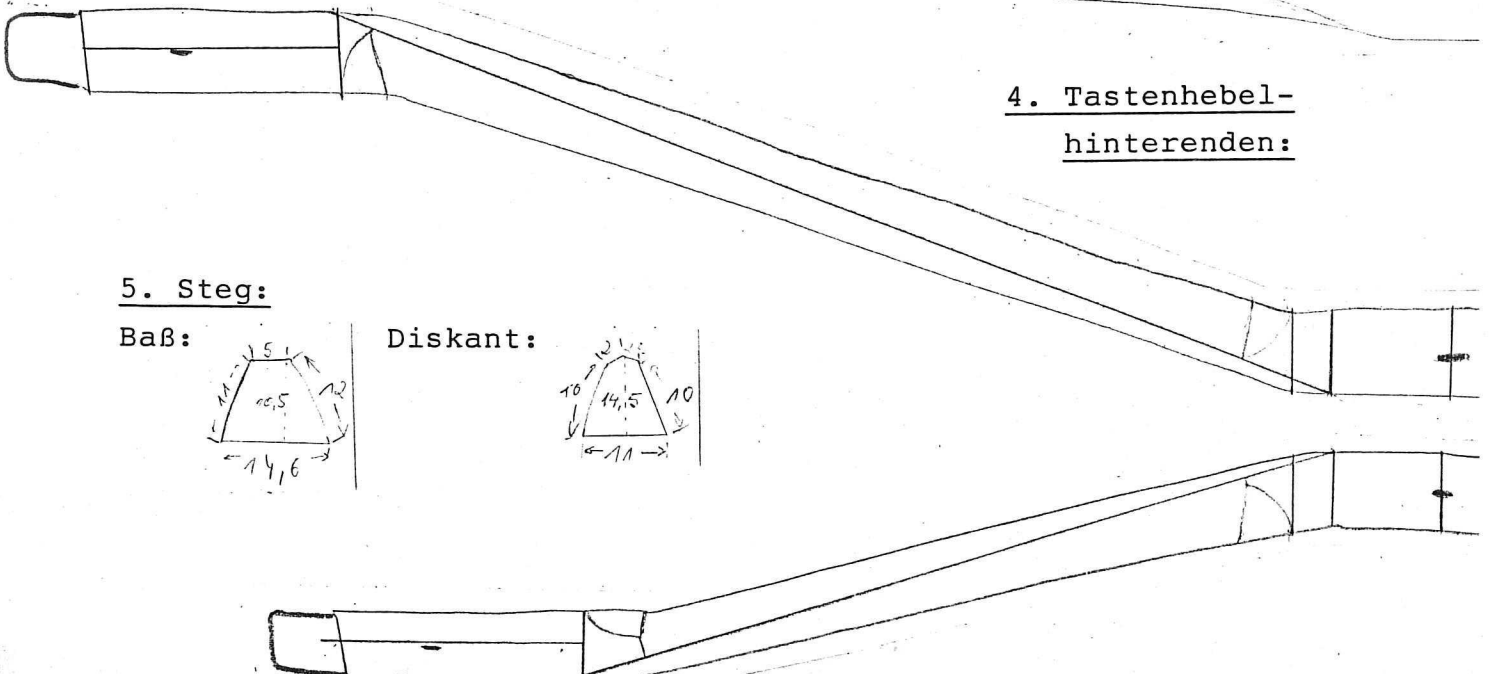

5. Steg:

Baß:

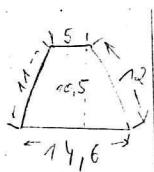

Diskant:



INV.NR. 46116

Gebundenes Clavichord

Vermutlich von Christoph Friedrich Schmahl, Regensburg 1790er Jahre

1. Resonanzraum:

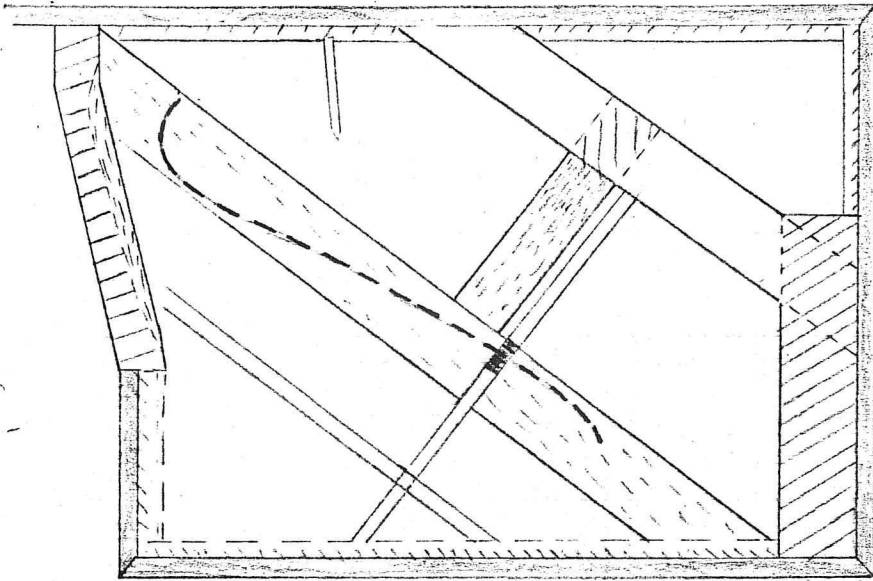

2. Steg:

Baß:

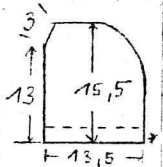

Diskant:

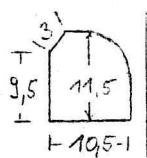

Stegende:

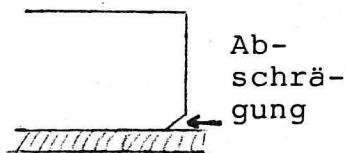

3. Tastenführungs-
rechen:

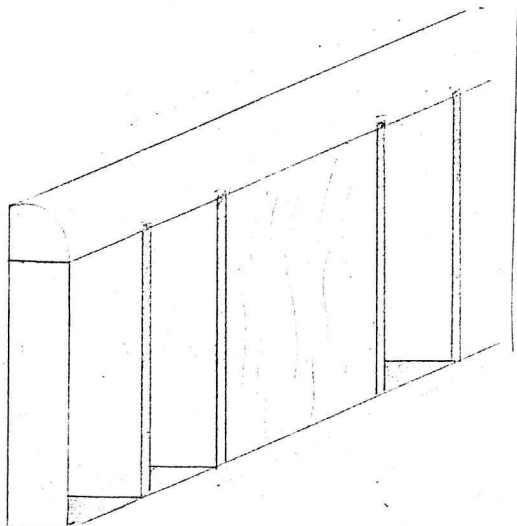

4. Untertaste:
(von unten)

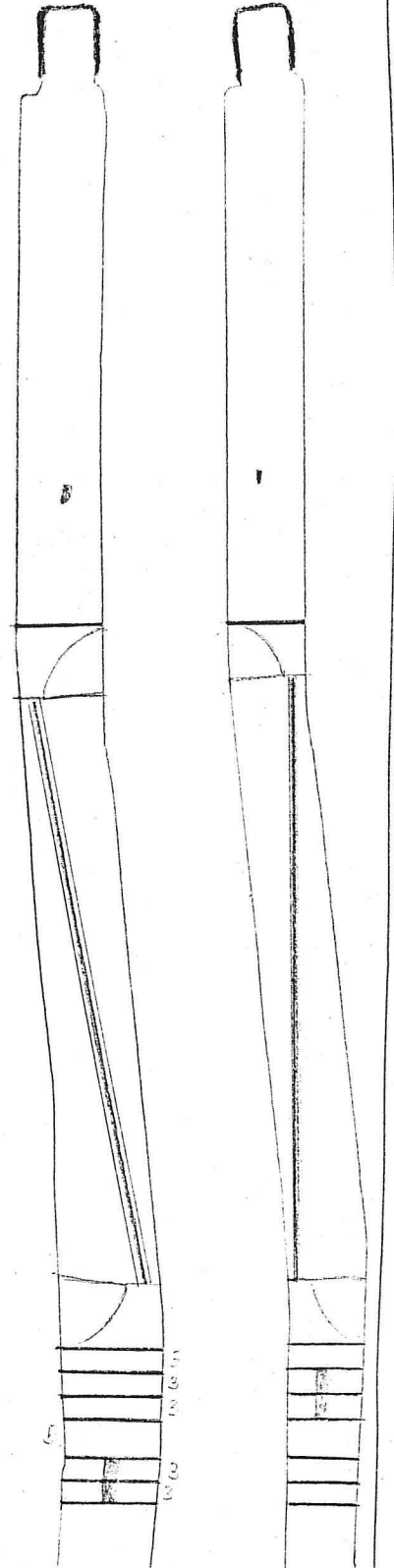
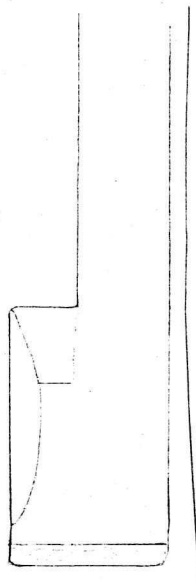

5. Tastenhebelhinterende:

INV.NR.5393**Bundfreies Clavichord**

Gottfried Joseph Horn, Nickern bei Dresden 1796

1. Steg:

Baß:

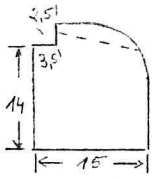

Diskant:

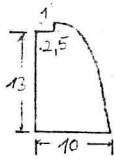
2. Rippe:

(nicht original)

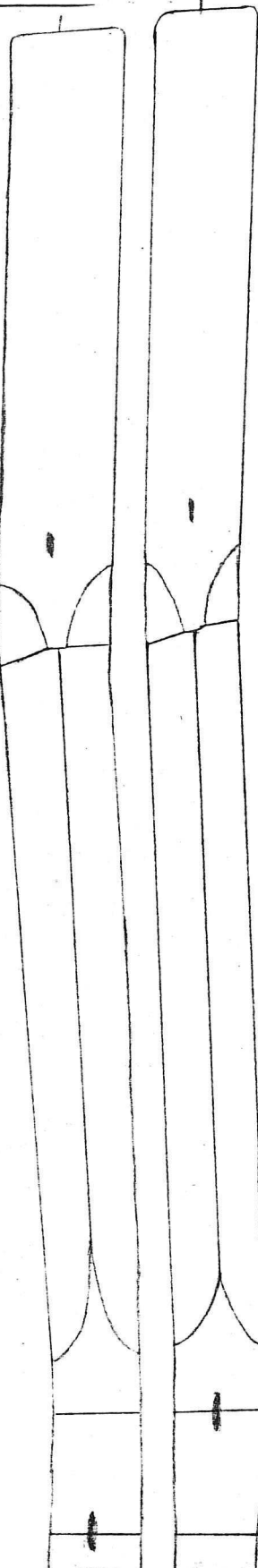
3. Tastenhebelhinterenden:

INV.NR.17214

Bundfreies Clavichord

Jacob Friedrich und Christian Carl Schmahl, Regensburg 1812/15

1. Resonanzraum: (Skizze nach dem im Museum befindlichen Plan)

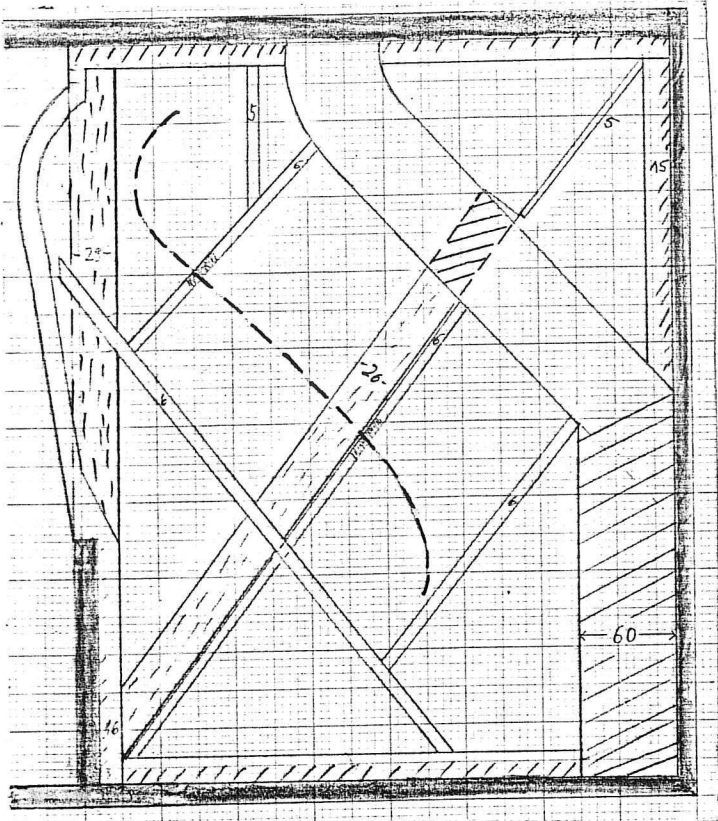

2. Steg:

Baß:

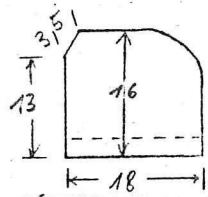

Diskant:

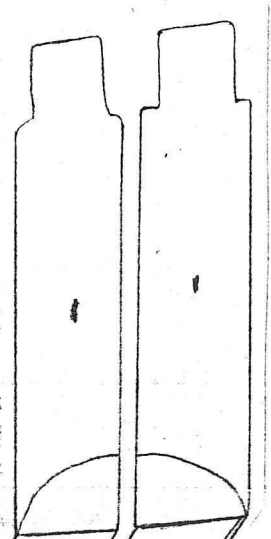
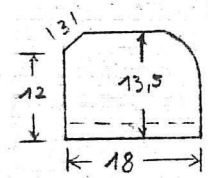

3. Tastenführungs-
rechen:

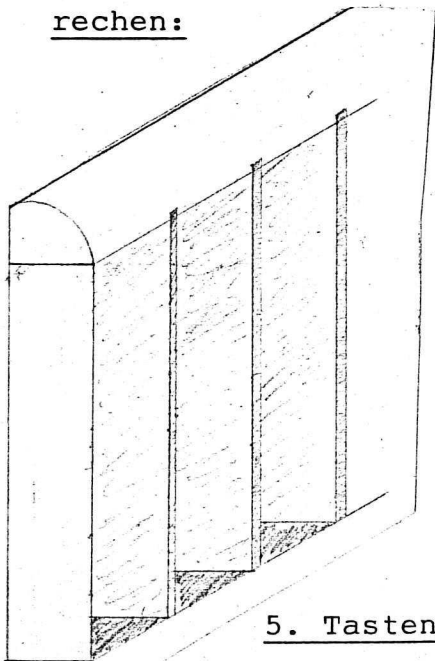

Stegende:

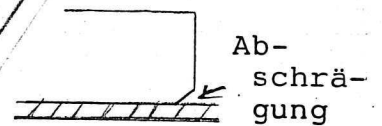

4. Untertaste:
(von unten)

Bohr-
loch

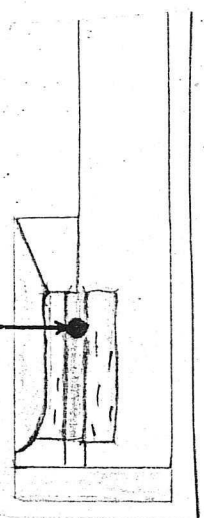

5. Tastenhebelhinterenden:

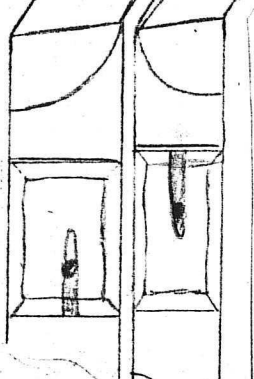

INV.NR.34072

Bundfreies Pedalclavichord

Möglicherweise von Carl Ludwig Glück, Friedberg/Hessen, 19.Jh.

1. Resonanzraum:

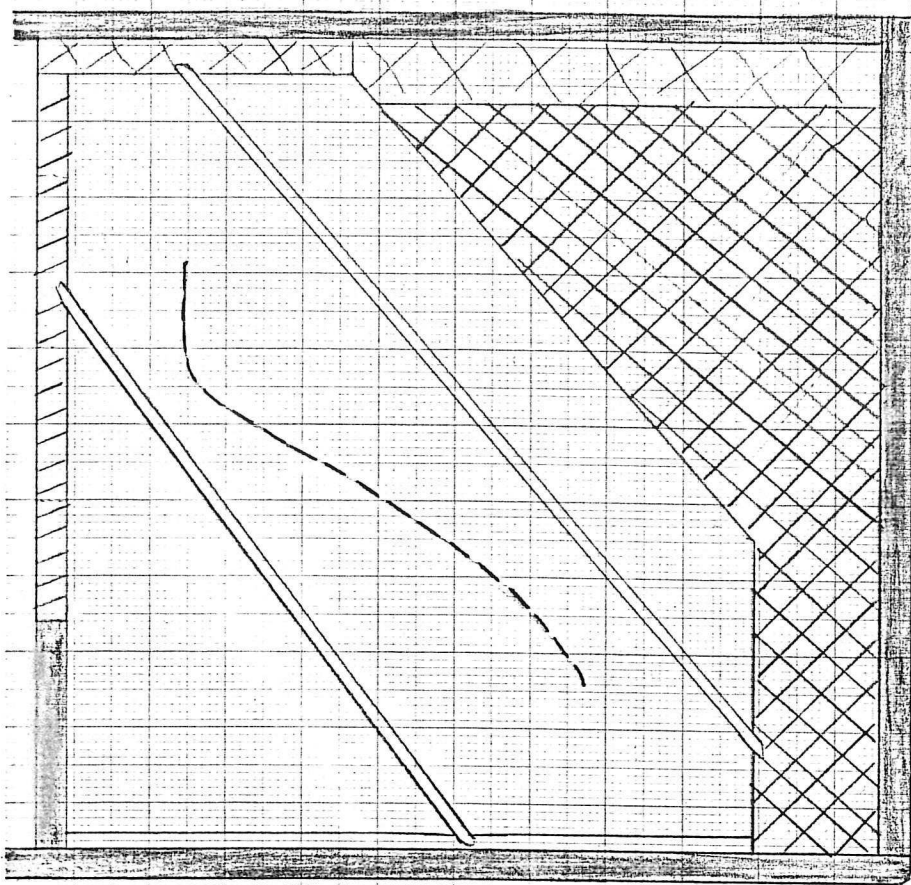

2. Steg:

Manualclavich.:

Baß:

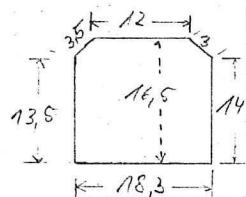

Diskant:

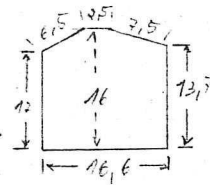

Pedalclavich.:

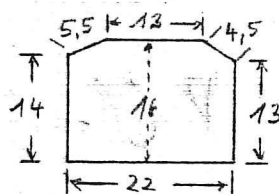

Stegende:

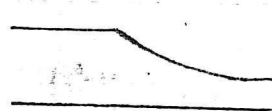

3. Damm:

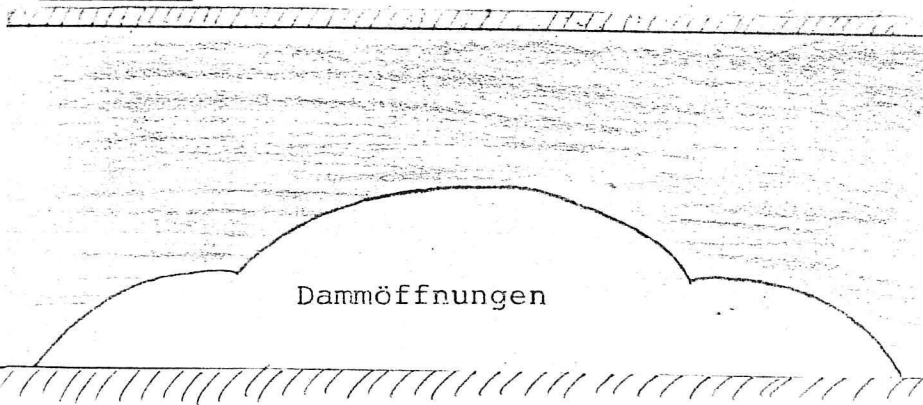

5. Untertaste:

Bohrloch

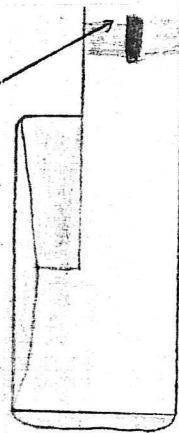

4. Tastenhebel: (Seitenansicht)

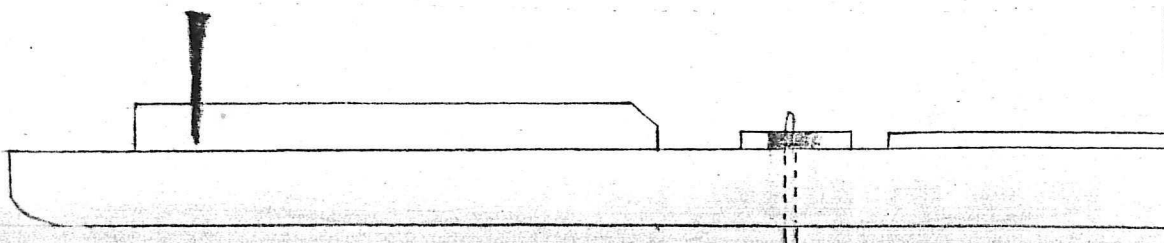

6. Waagebalken:

Manualclavichord:

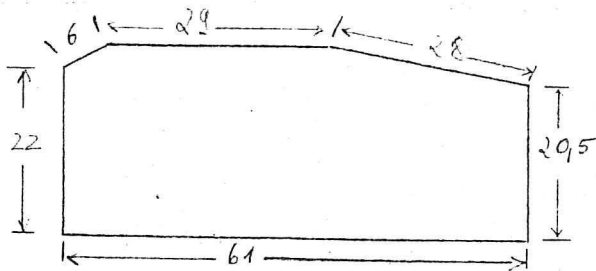

Pedalclavichord:

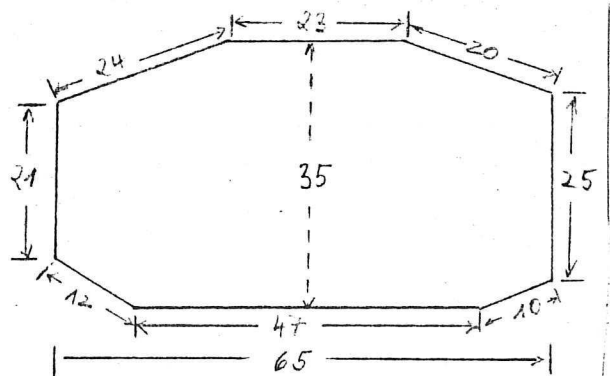

7. Resonanzraum: (Pedalcl.)

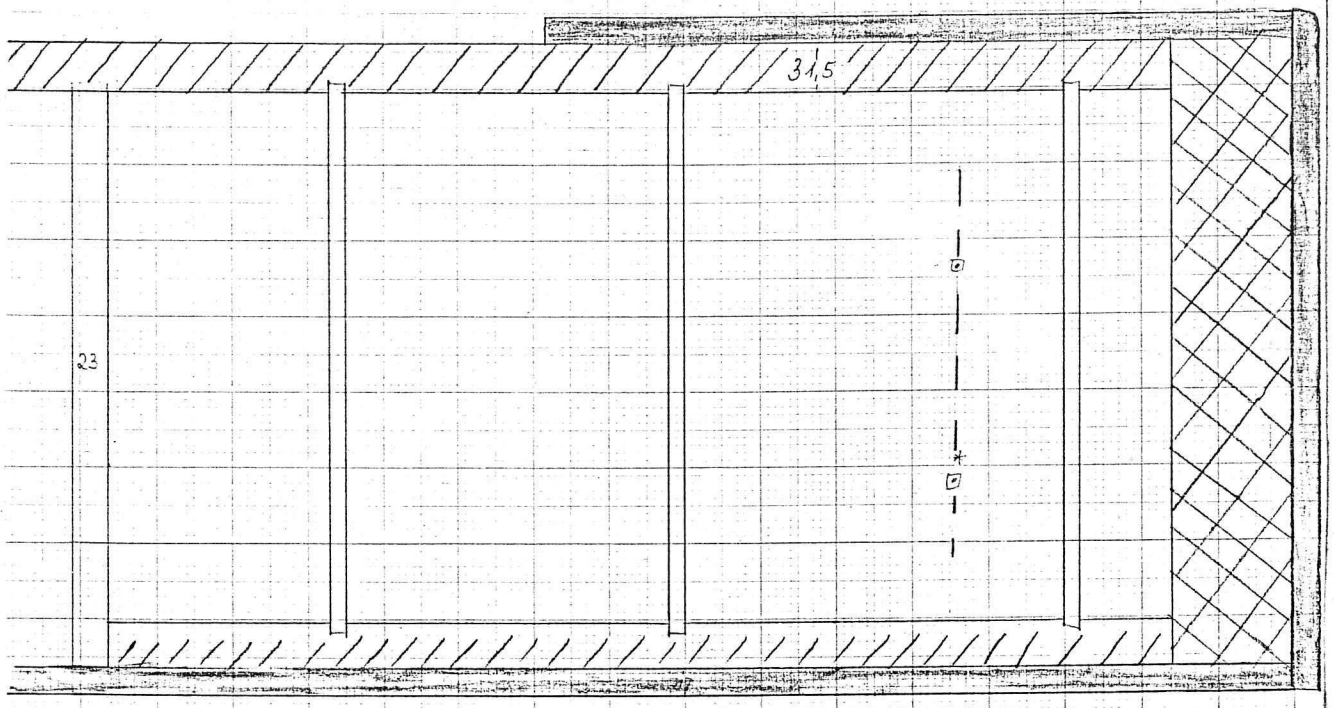

8. Tangentenhebelauflagerahmen:

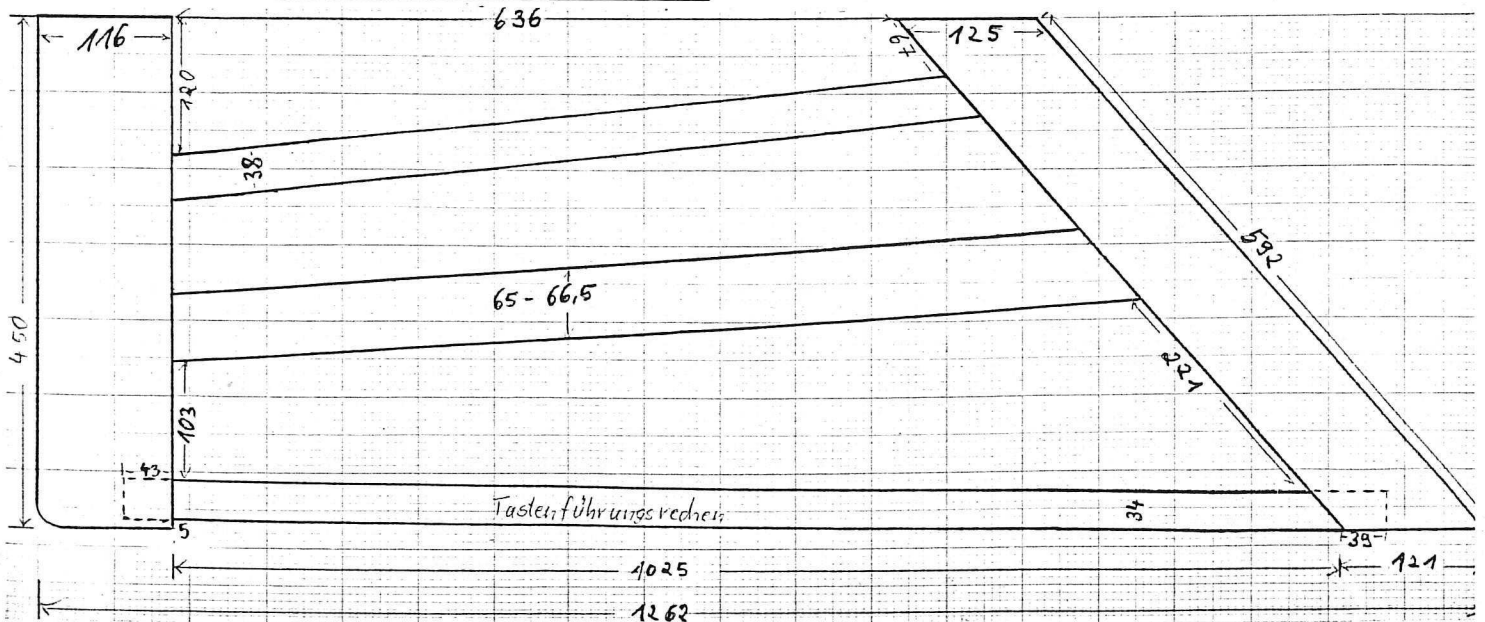

MUSIKINSTRUMENTENMUSEUM IM MÜNCHNER STADTMUSEUM

INV.NR. 70-103

Gebundenes Clavichord

deutsch um 1700

1. Steg:

Baß:

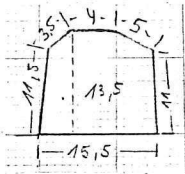

Diskant:

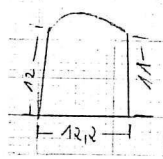

2. Waagebalken:

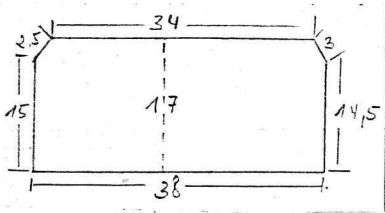

3. Stirnflächenverzierung:

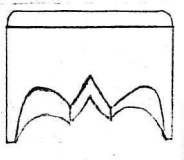

4. Tastenhebel:

(Seitenansicht)

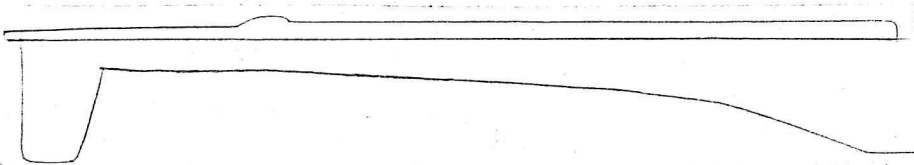

5. Tastenhebelhinterende:

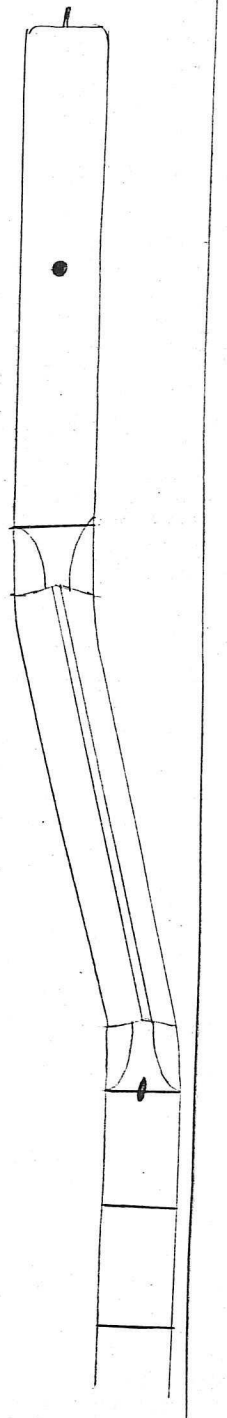

INV.Nr.82-2

Gebundenes Clavichord mit "Lautenzug"

deutsch, 1.Hälfte oder Mitte 18. Jahrhundert

1. Resonanzraum:

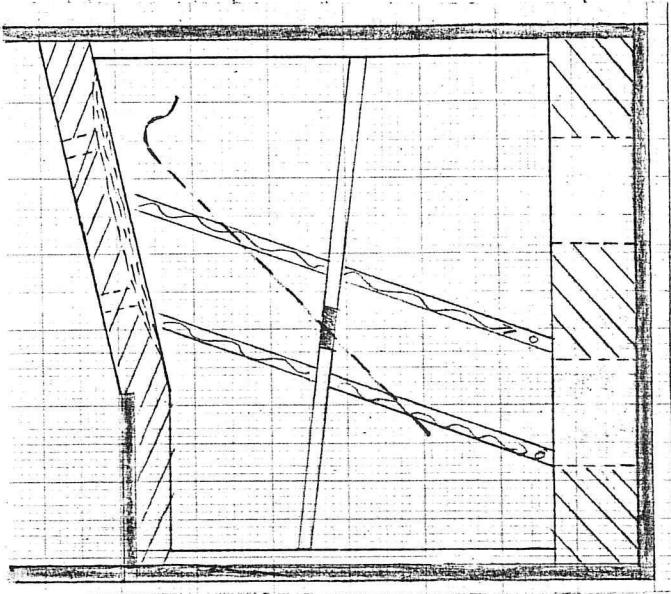

2. Stützstreben im Resonanzraum:

(vermutlich nicht original)

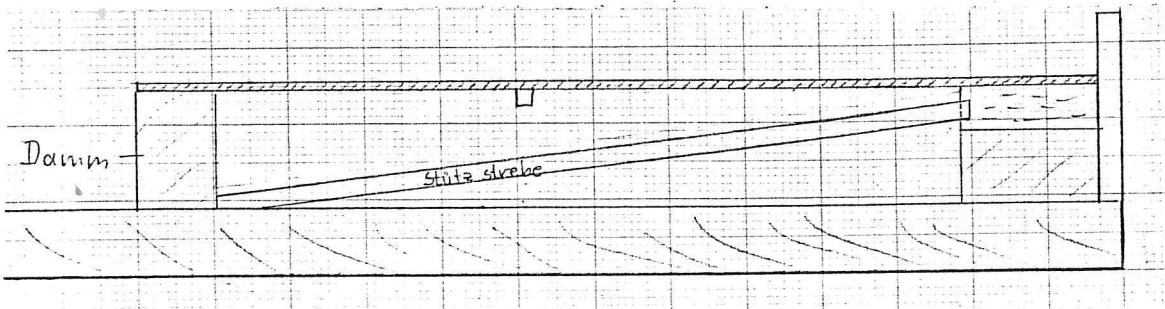

3. Steg:

Baß:

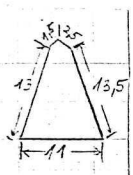

Diskant:

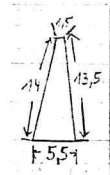

Stegende:

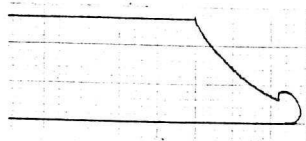

4. Untertaste:
(Seitenansicht)

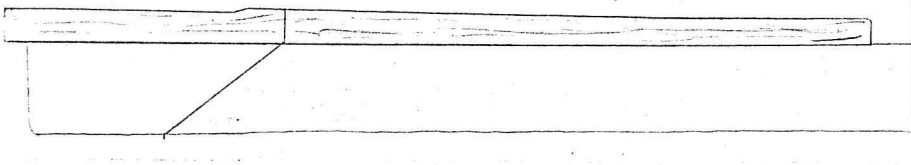

5. Obertaste:
(Seitenansicht)

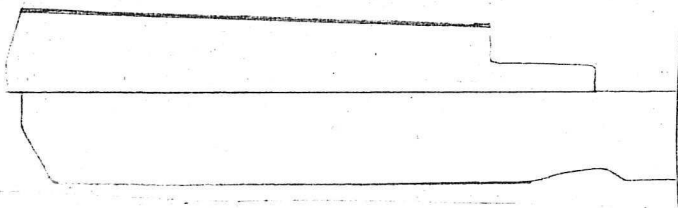

6. Stirnfläche der Untertaste:

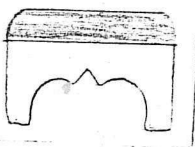

7. Klaviaturbacke:

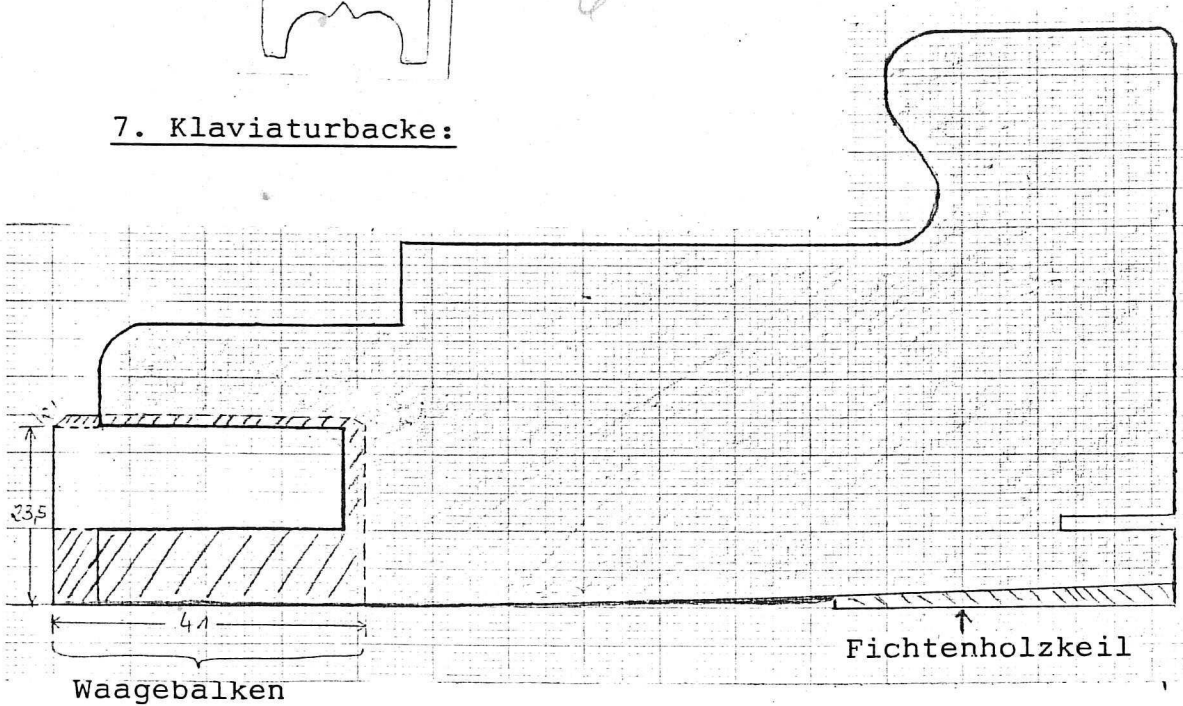

8. Tastenhebelhinterende:

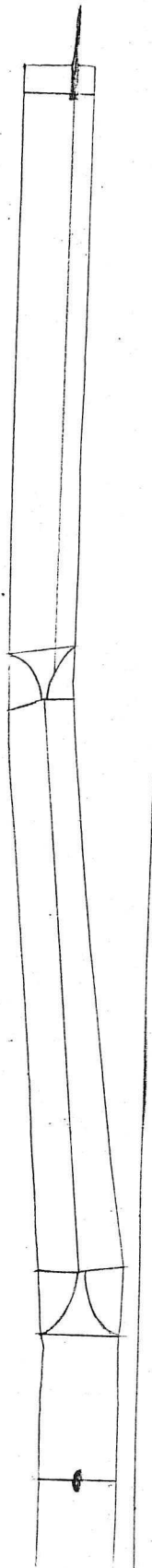

INV.NR.69-15

Gebundenes Clavichord

deutsch, 2.Hälfte 18. Jahrhundert

1. Resonanzraum:

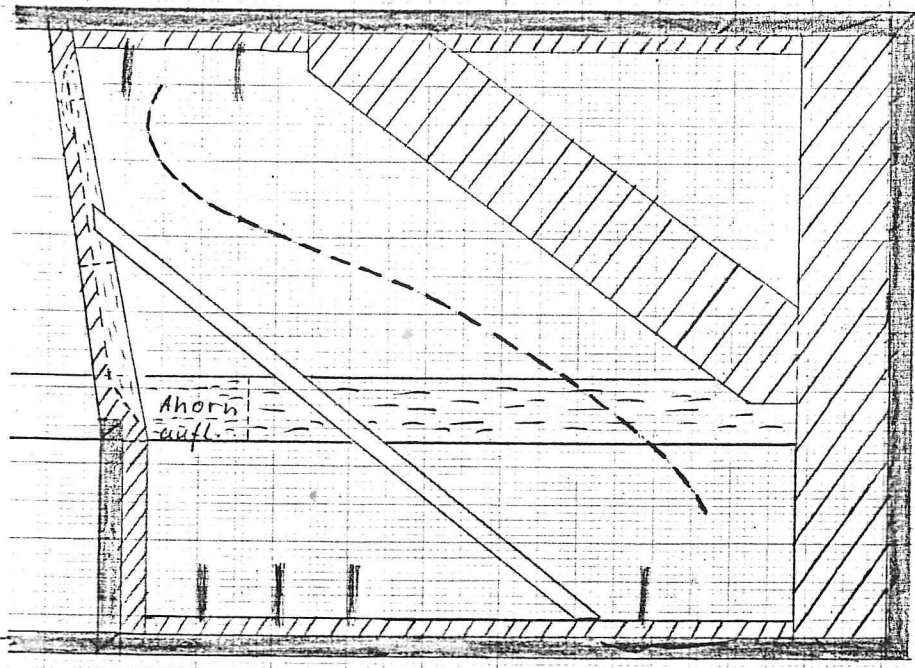

2. Tastenhebel-
hinterende:

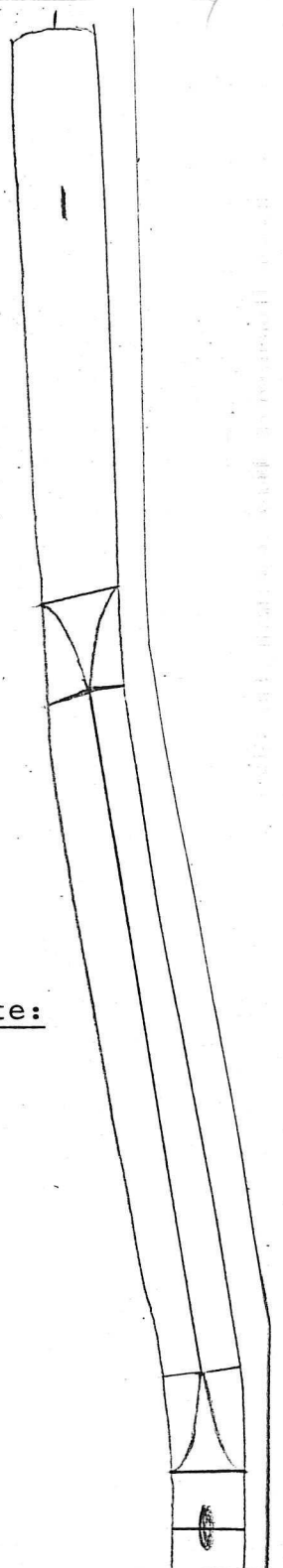

3. Waagebalken:

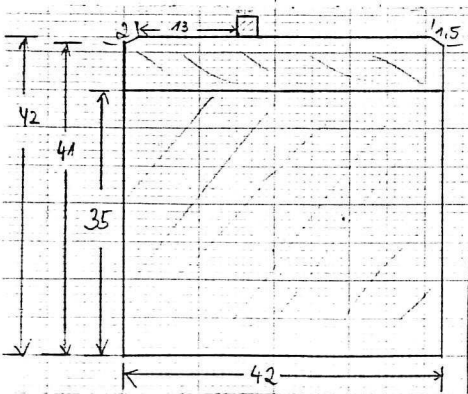

4. Fichtenrippe:

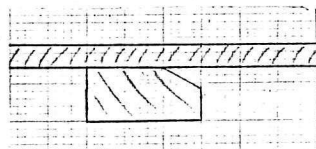

5. Stirnfläche:

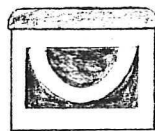

7. Untertaste:
(von unten)

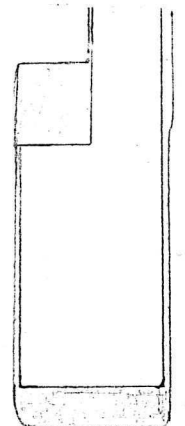

6. Steg:

Baß:

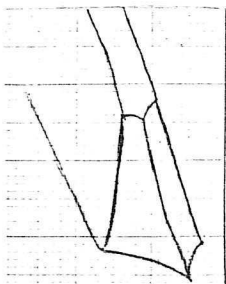
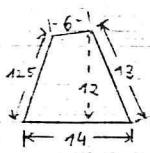

Diskant:

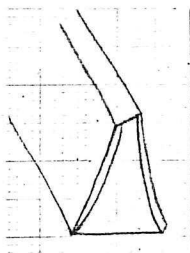
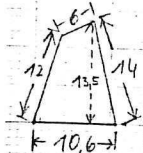

INV.NR.44-1

Gebundenes Clavichord

deutsch, 2.Hälfte 18. Jahrhundert

1. Resonanzraum:

(teilweise nicht original)

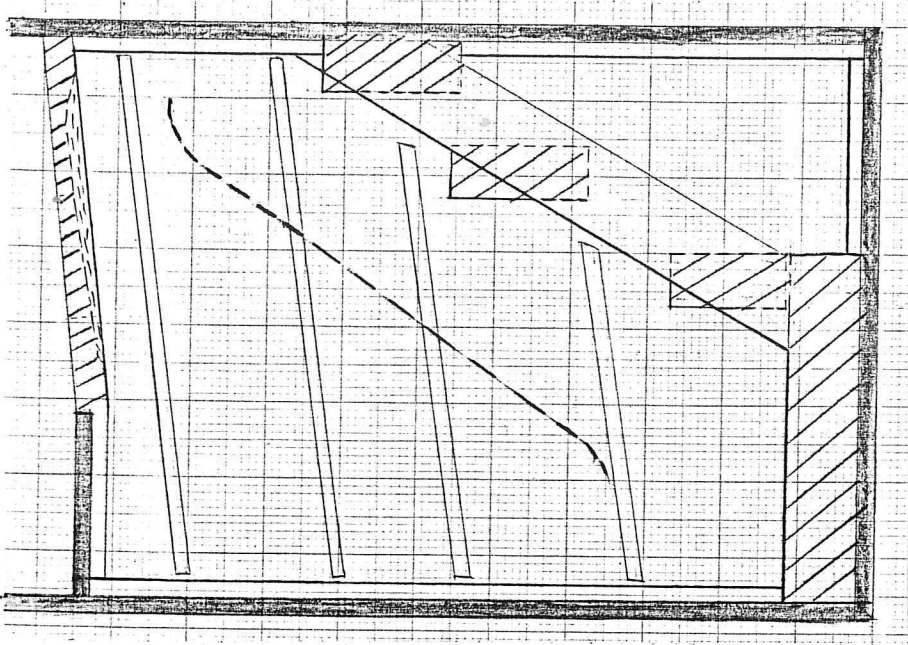

2. Steg:

Baß:

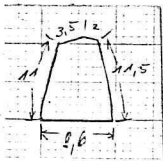

Diskant:

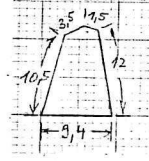

3. Untertaste:

(Seitenansicht)

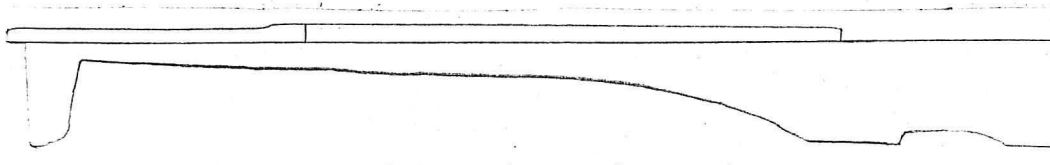

4. Tastenhebelhinterende:

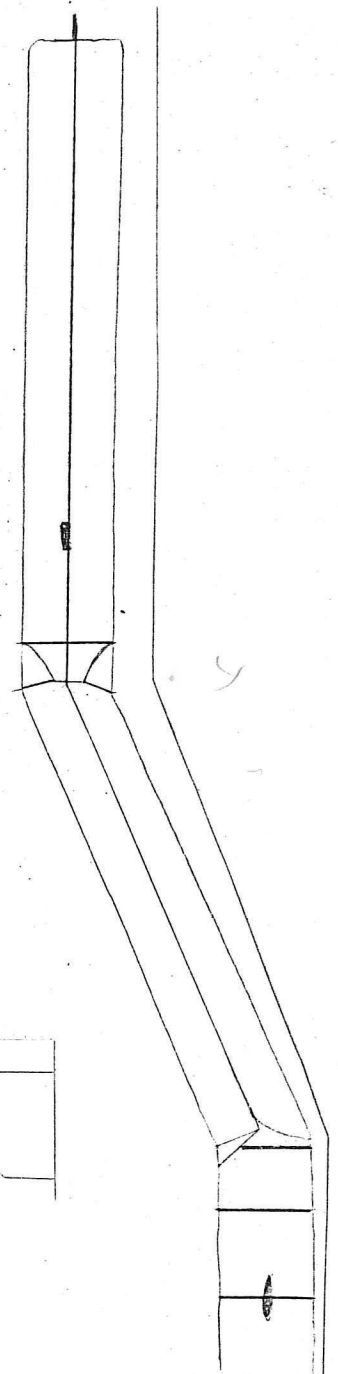

INV.NR. 44-2

Bundfreies Clavichord

Vermutlich von Gottfried Joseph, Nickern bei Dresden 1772/1797

1. Resonanzraum: (Skizze nach dem Foto der Restaurierung)

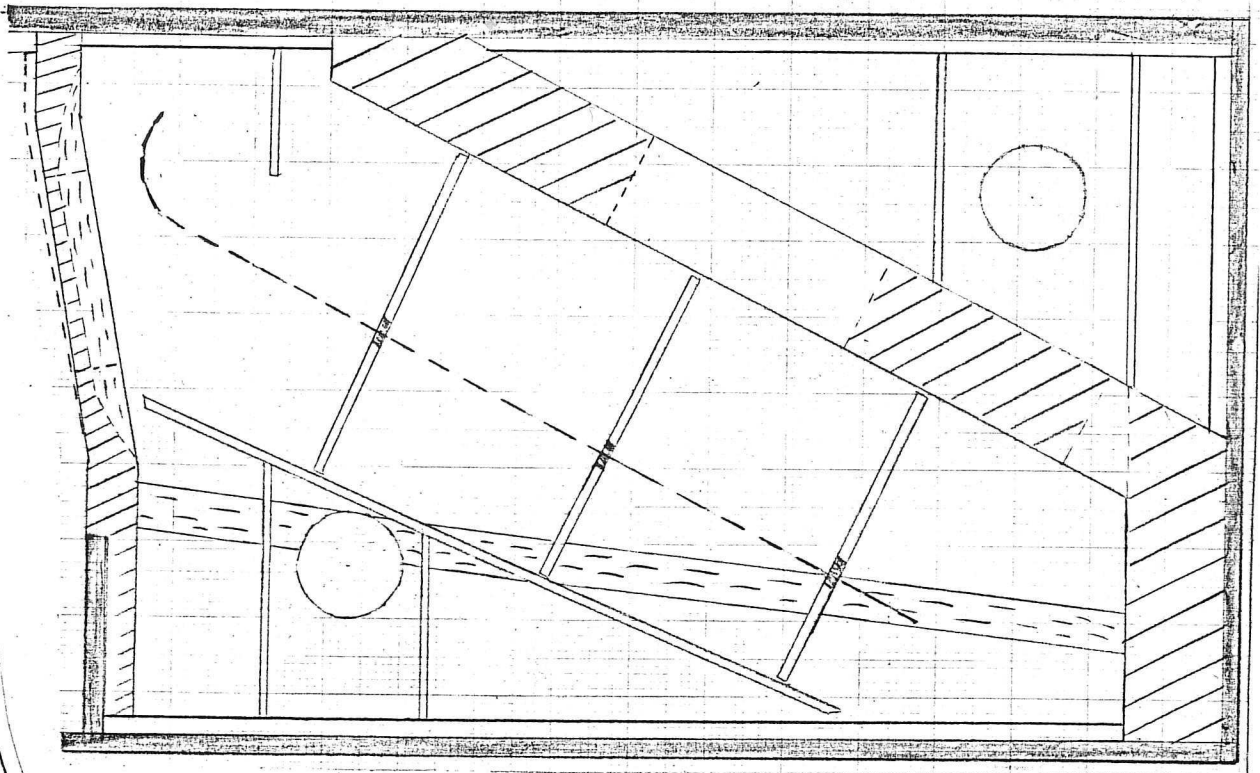

2. Steg:

Baß:

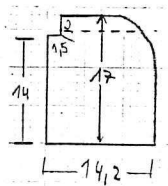

Diskant:

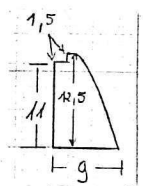

Stegende:

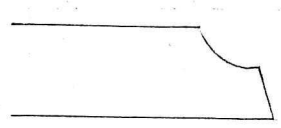

3. Tastenhebelhinterende:

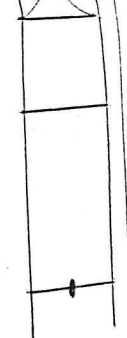

INV.NR.44-3

Bundfreies Clavichord

deutsch, letztes Drittel 18. Jahrhundert

1. Waagebalken:

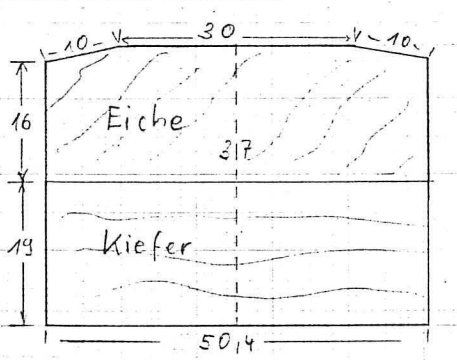

2. Untertaste:
(Seitenansicht)

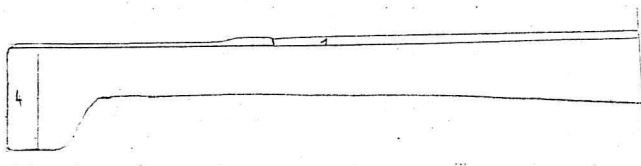

3. Furnier des Korpus:

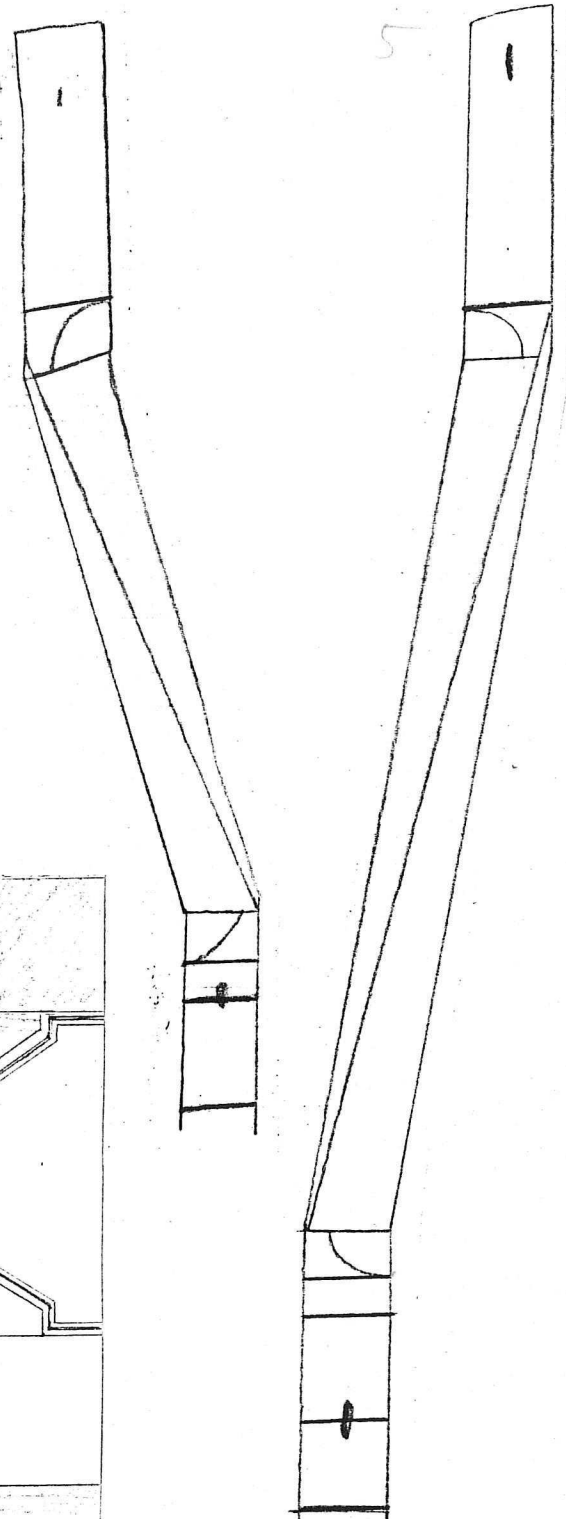
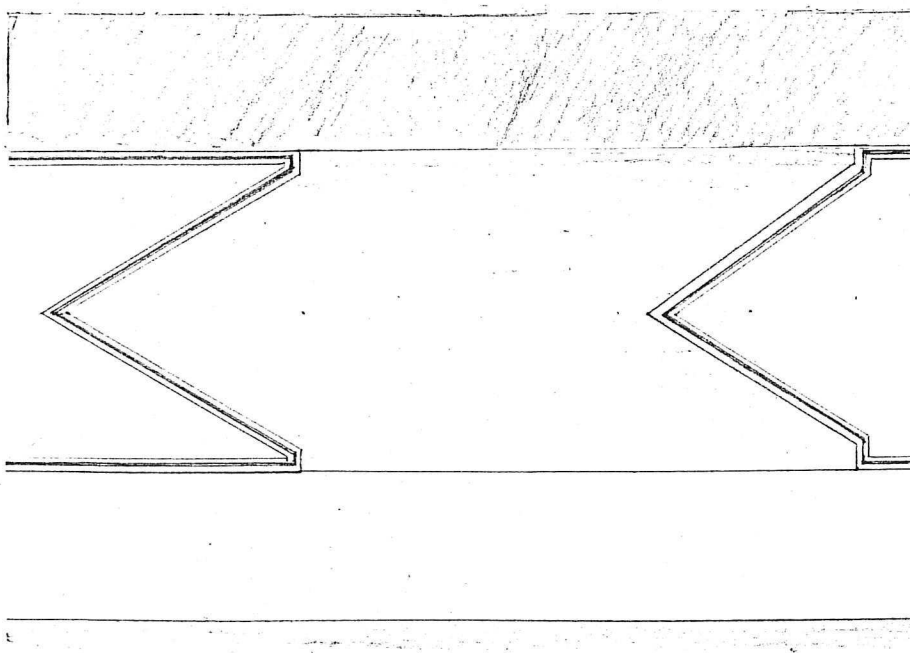

4. Tastenhebelhinterenden:

INV.NR. 44-4

Bundfreies Clavichord

deutsch oder schwedisch, zwischen 1810 und 1820

1. Resonanzraum:

x Damm muß dabei sein (vgl Text)

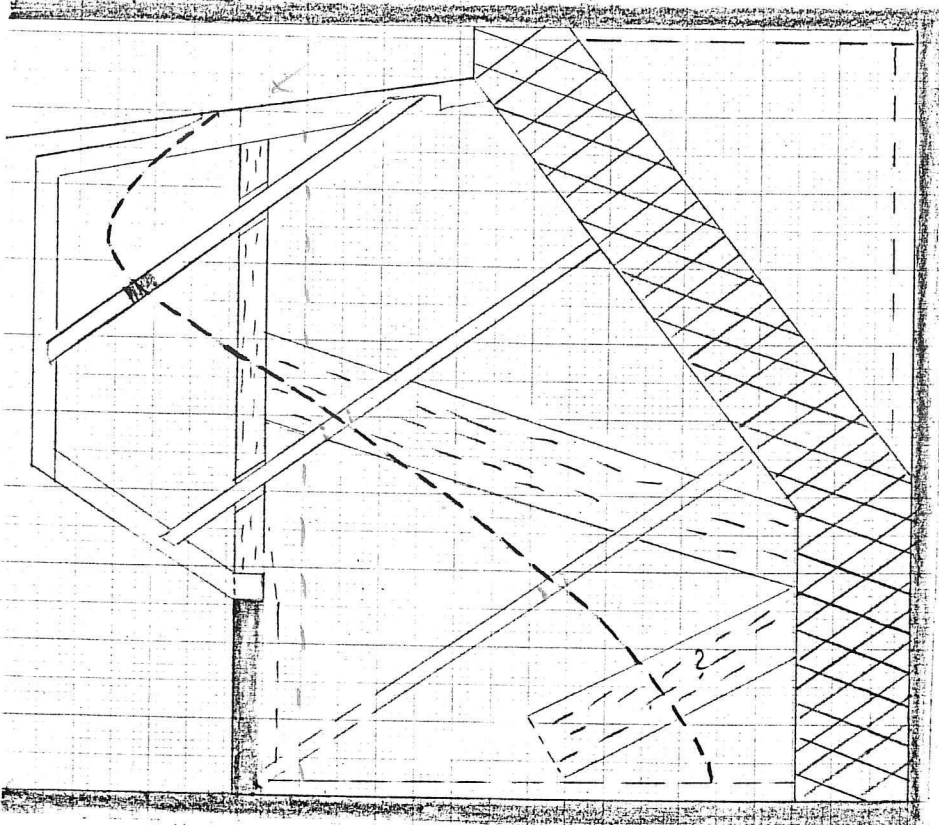

2. Tastenhebel:

(unten)

4
6

3. Damm:

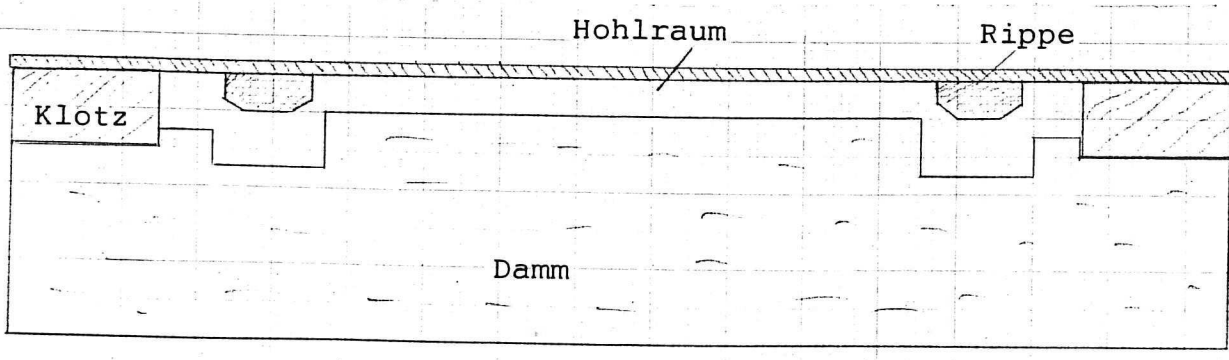

4. Steg:

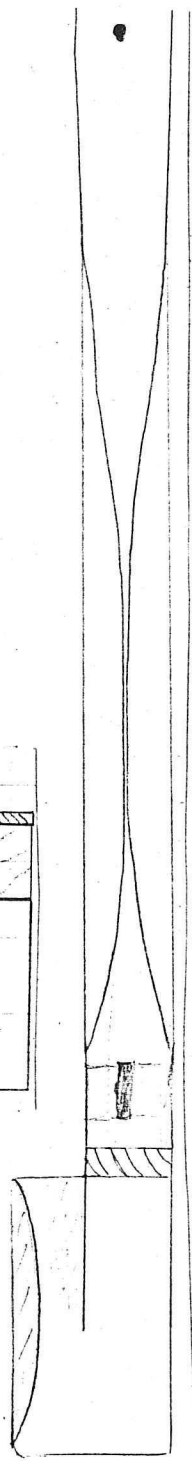
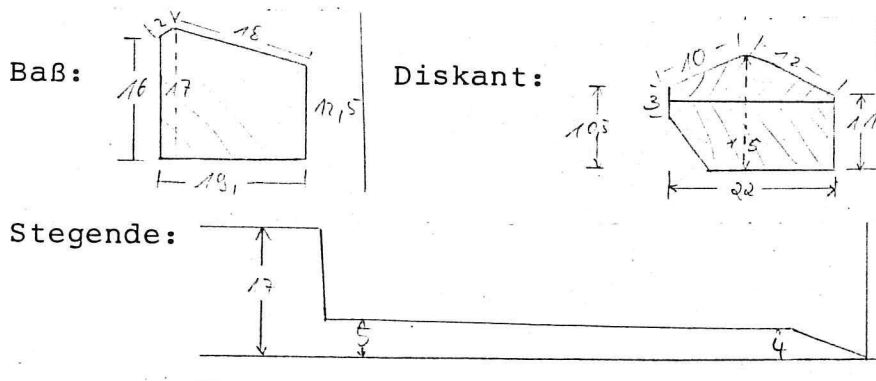

5. Untertaste: (Seitenansicht)

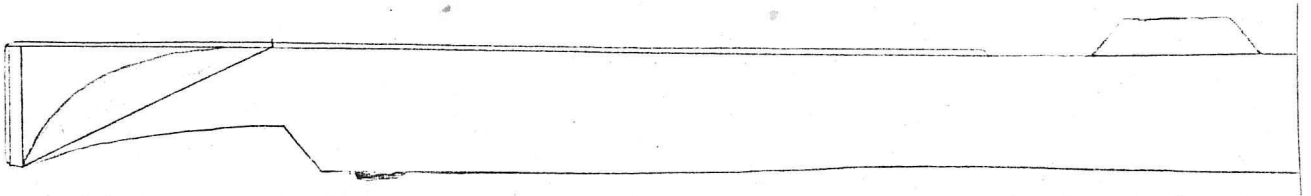

6. Klaviaturrahmen:

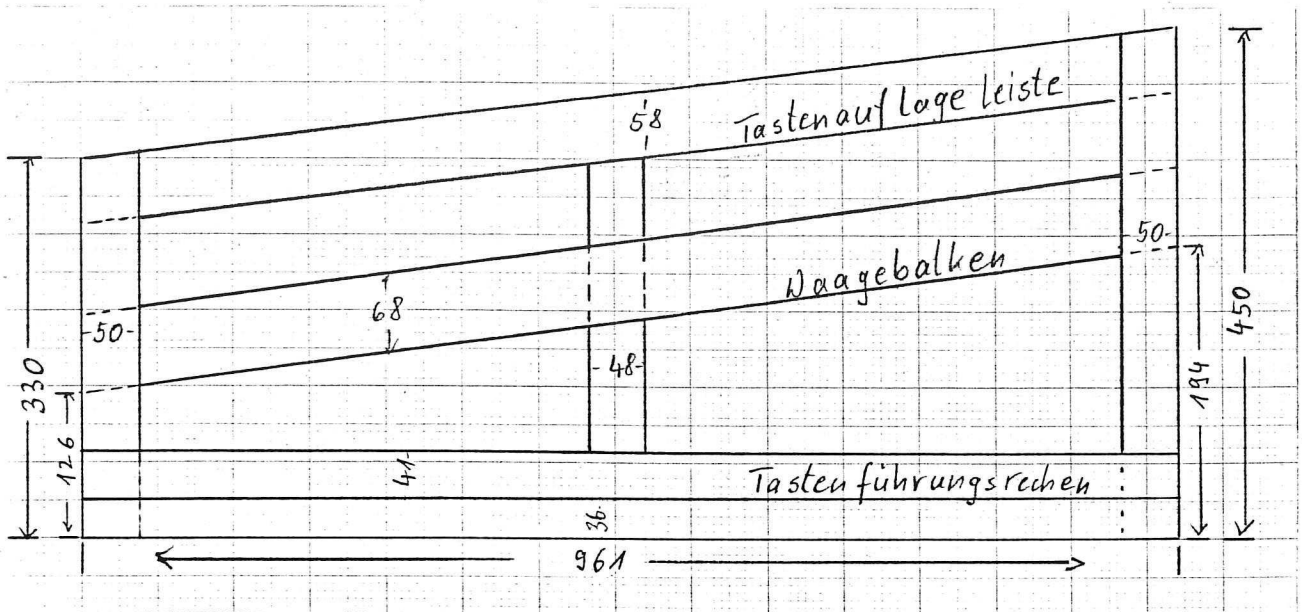

7. Klaviaturschlitten: (Auflagerahmen)

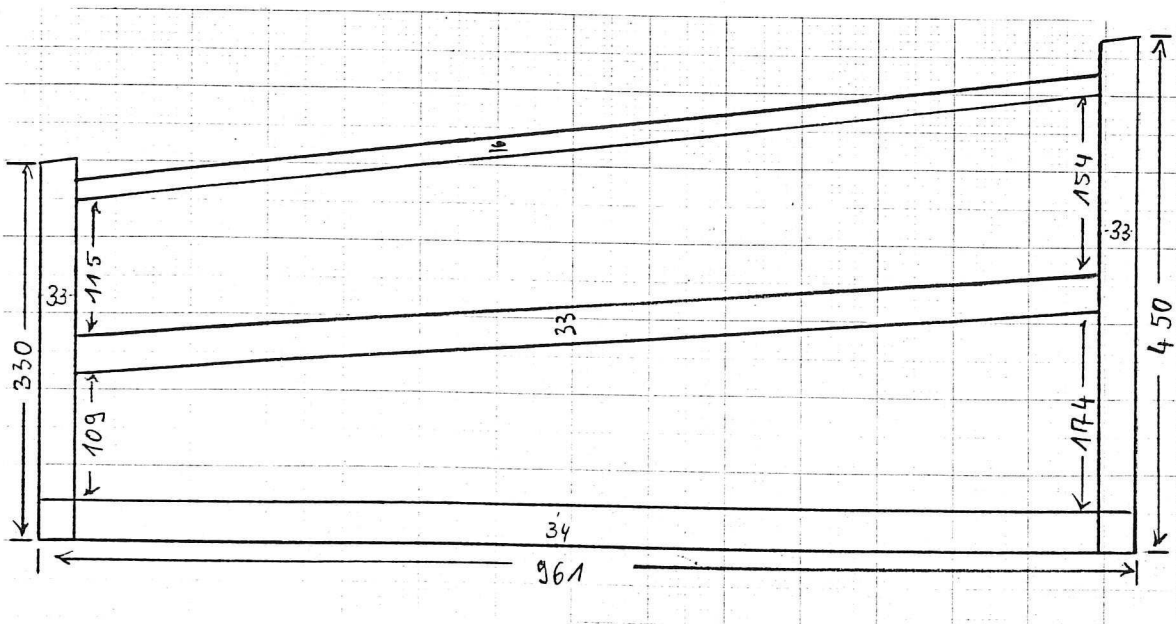

BAYERISCHES NATIONALMUSEUM, MÜNCHEN

INV.NR. 28/1818

Gebundenes Clavichord

deutsch, 2.Hälfte 18. Jahrhundert

Rosette fehlt!

1. Resonanzraum:

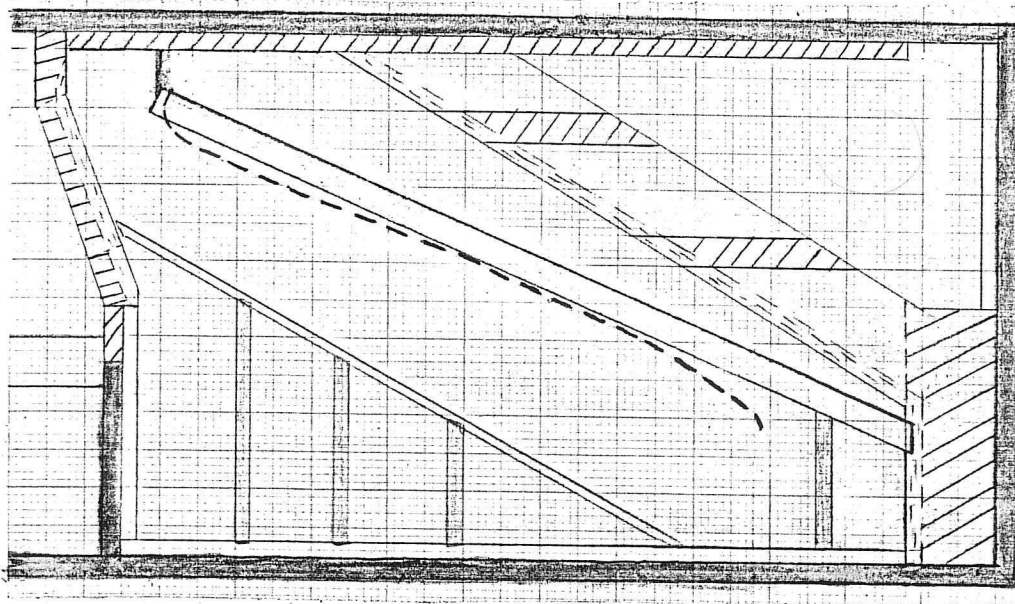

2. Steg:

Baß:

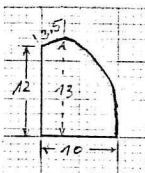

Diskant:



3. Untertaste: (Seitenansicht)

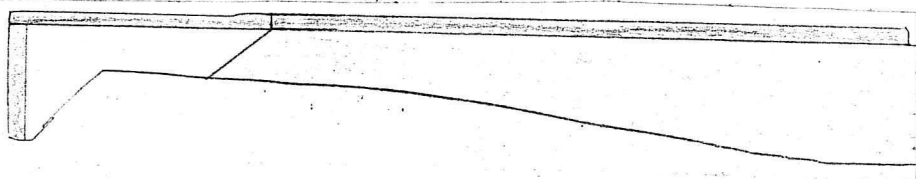

4. Obertaste: (Seitenansicht)

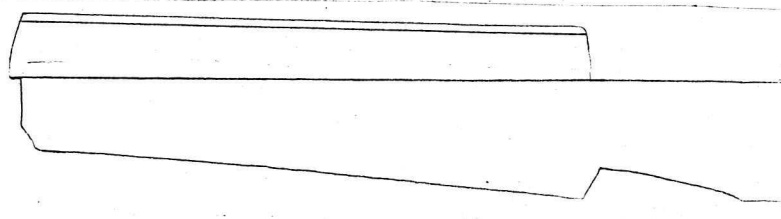

5. Tastenhebelhinterende:

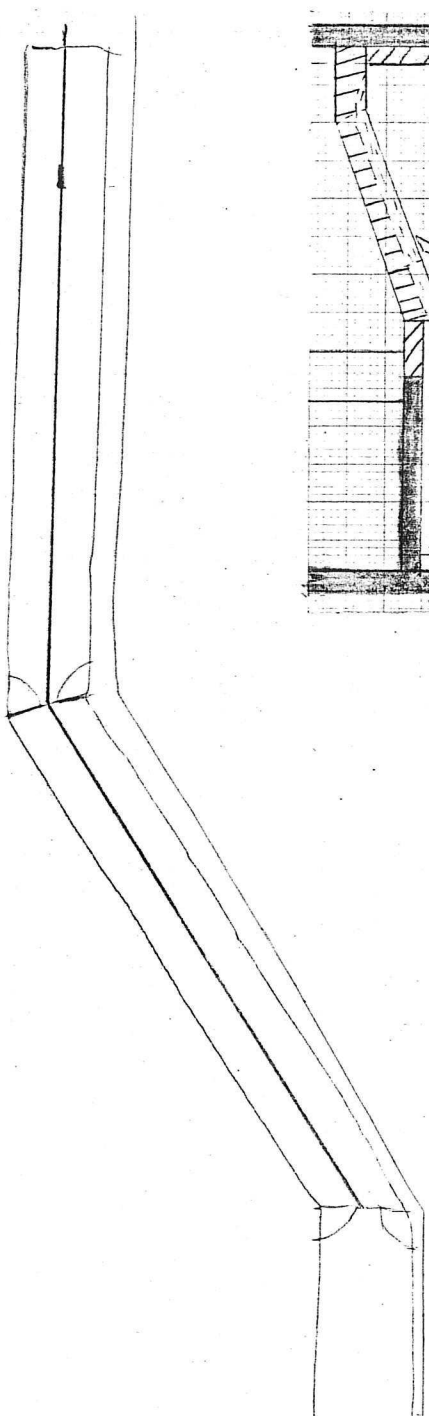

INV.NR.: MU 72

Gebundenes Clavichord

Christoph Friedrich Schmahl, Regensburg 1790 oder 96

1. Resonanzraum:

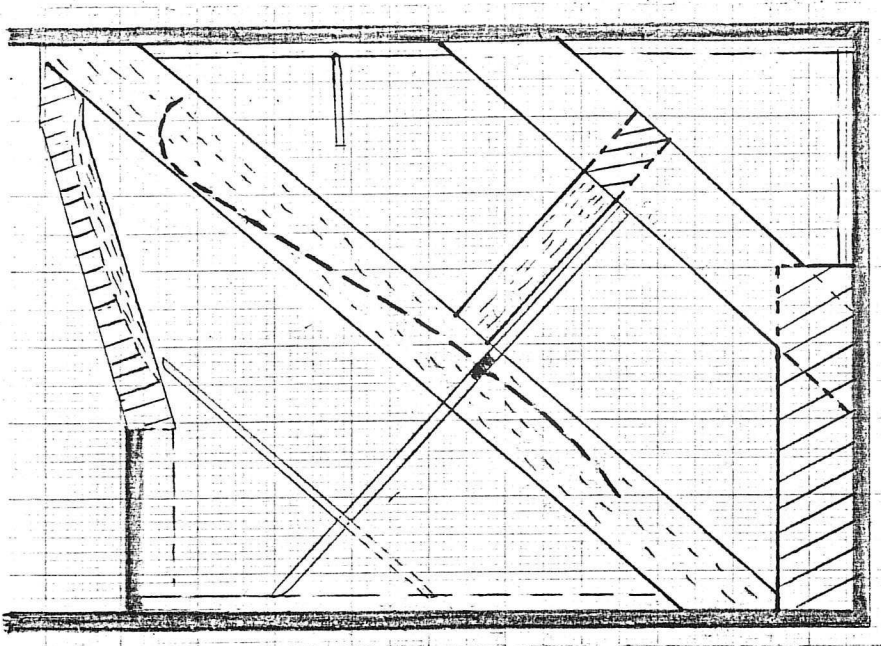

2. Steg:

Baß:

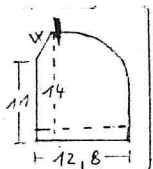

Diskant:

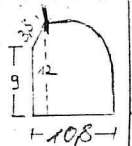

Stegende:

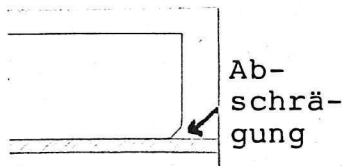

3. Tastenführungs-
rechen:

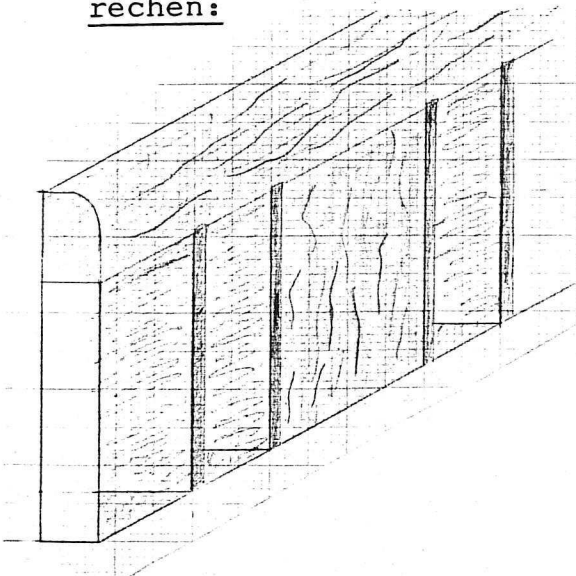

4. Untertaste:
(von unten)

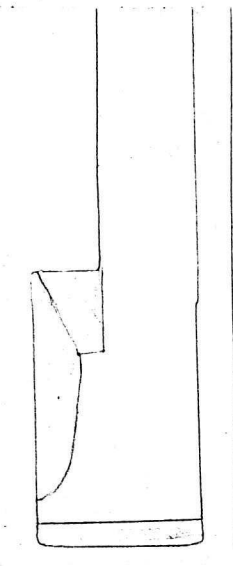

5. Tastenhebelhinter-
ende:

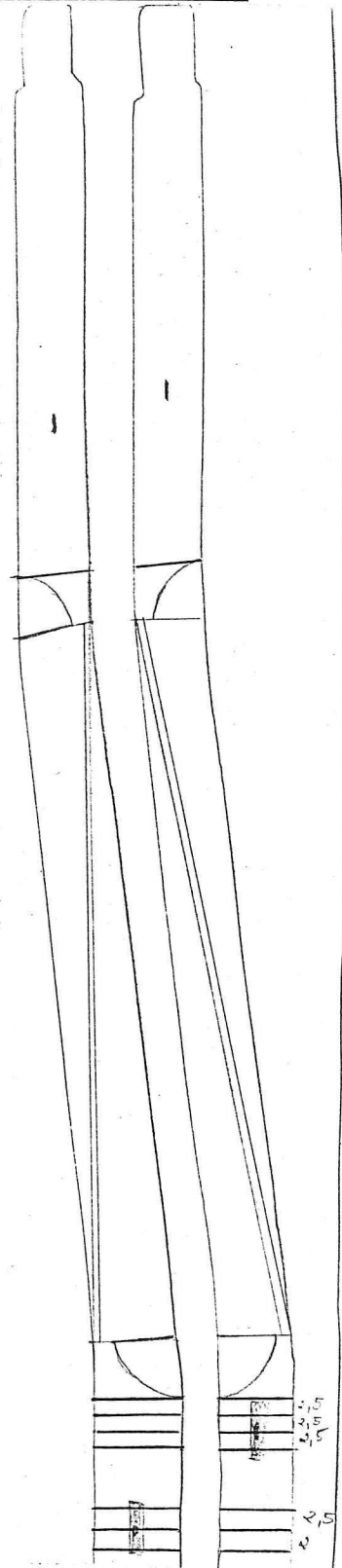

BAYERISCHE STAATSBIBLIOTHEK, MÜNCHEN

Bundfreies Reiseclavichord

deutsch, Ende 18. Jahrhundert

1. Resonanzraum: (Rippen nicht original)

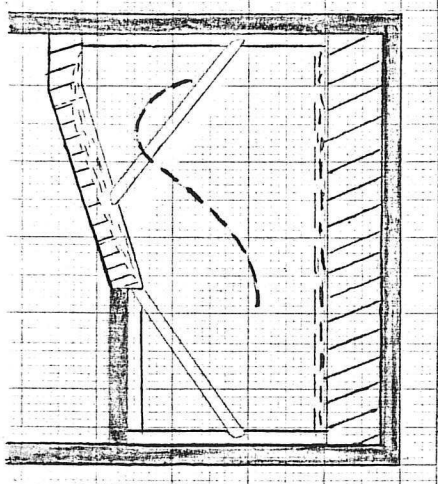

2. Steg:

Baß:

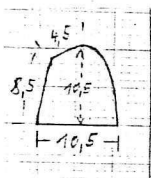

Diskant:

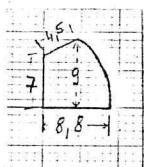

3. Untertaste:

(von unten)

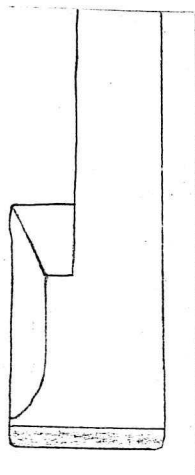

4. Tastenhebelhinterenden:

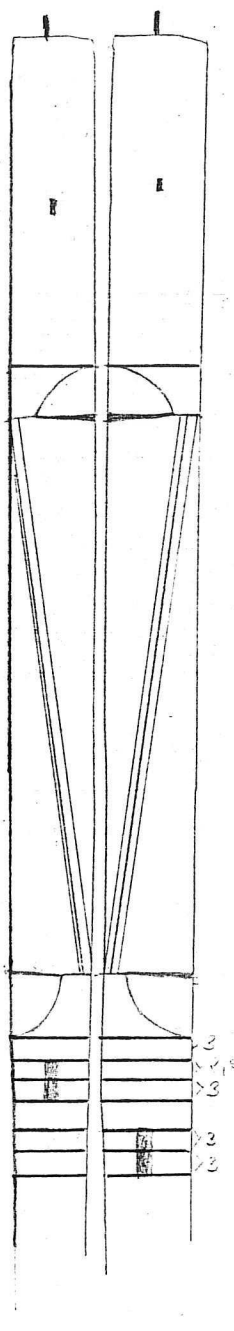

WÜRTTEMBERGISCHES LANDESMUSEUM STUTTGART

INV.NR.: G 4111

Bundfreies Clavichord

Johann Georg Christoph Schiedmayer, Neustadt a.d. Aisch, um 1780

1. Resonanzraum:

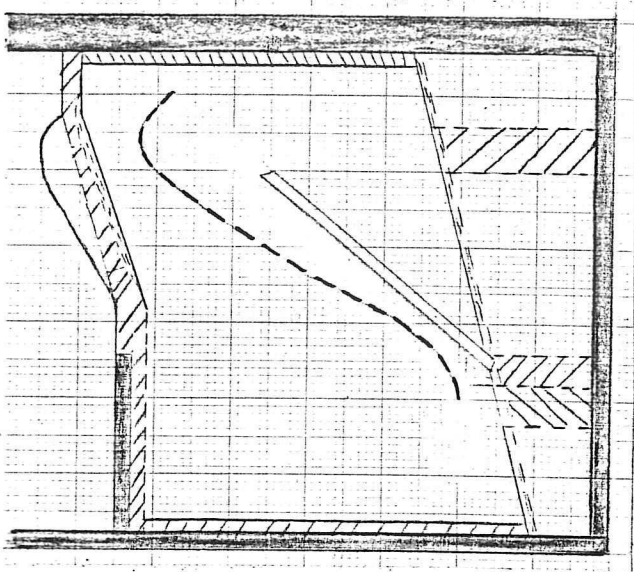

2. Tastenhebelhinterende:

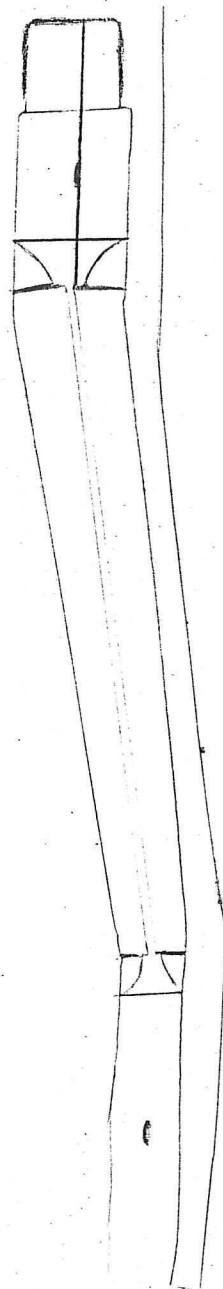

3. Steg:

Baß:

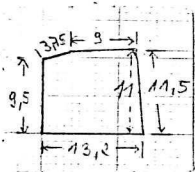

Diskant:

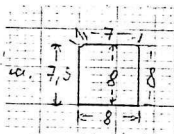

4. Untertaste:

(Seitenansicht)

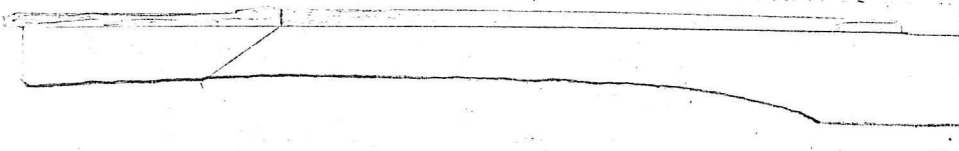

5. Obertaste:

(Seitenansicht)

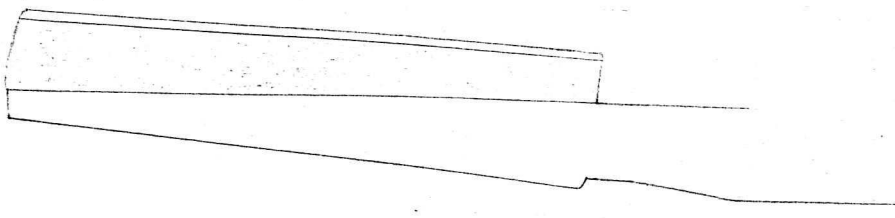

II. GRUNDRISS-SKIZZEN

DEUTSCHES MUSEUM, MÜNCHEN

Inv.Nr.18165

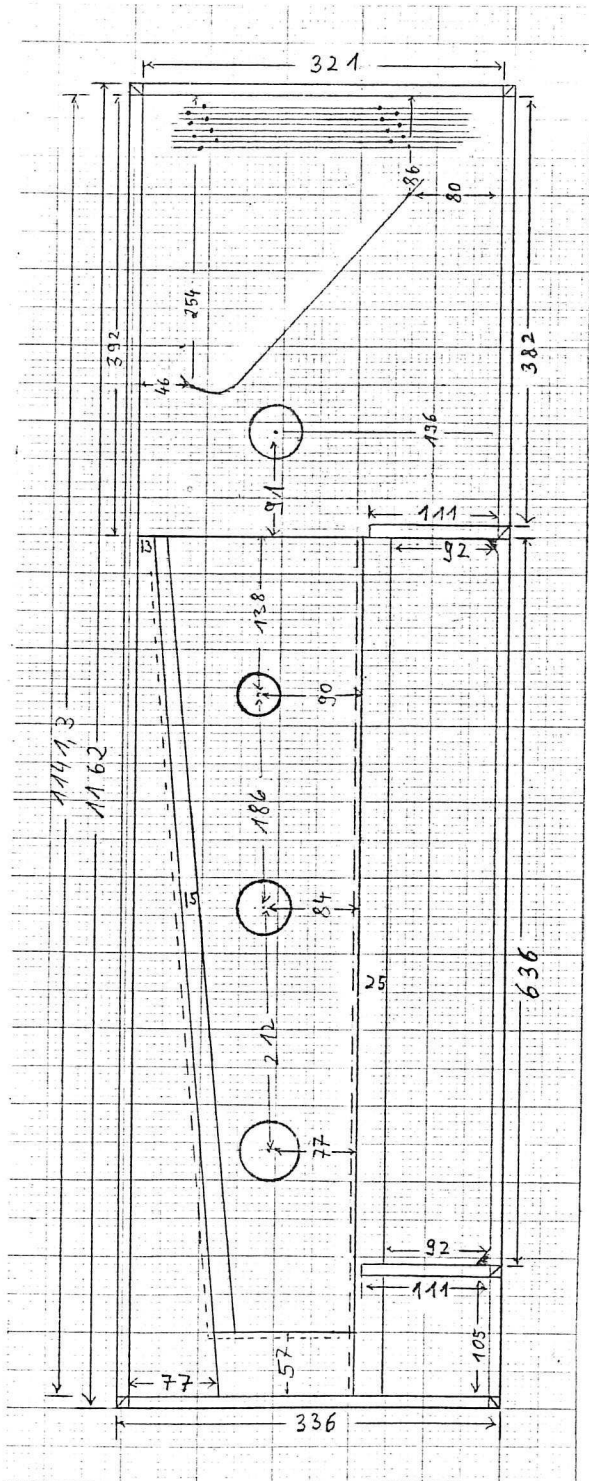

Inv.Nr.5392 (Weiss)

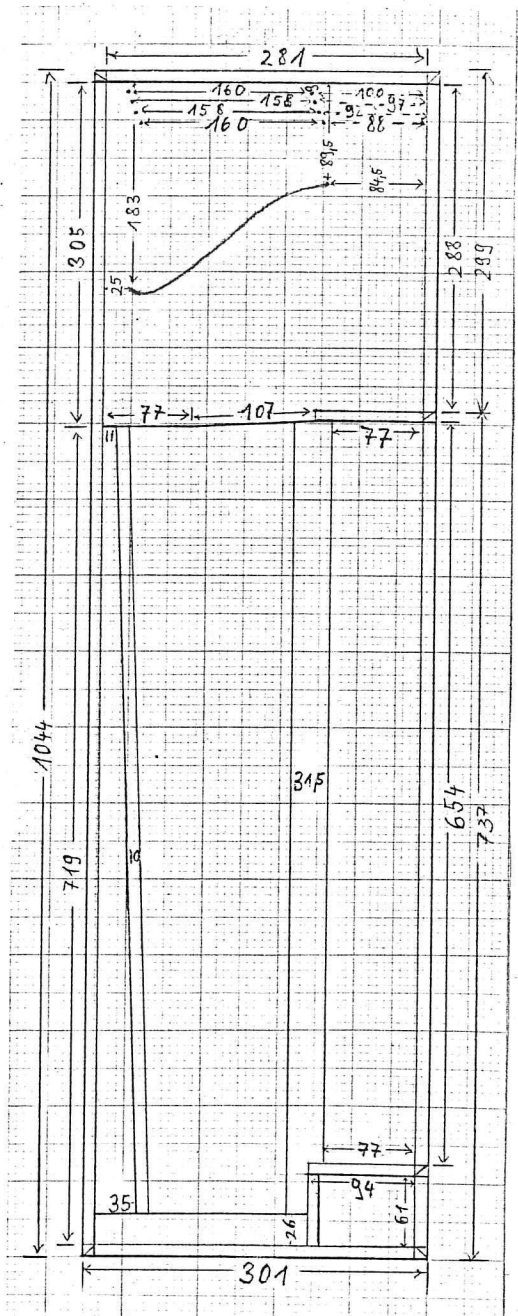

Inv.Nr.16816 (König)

Inv.Nr.20780 (Lemme)

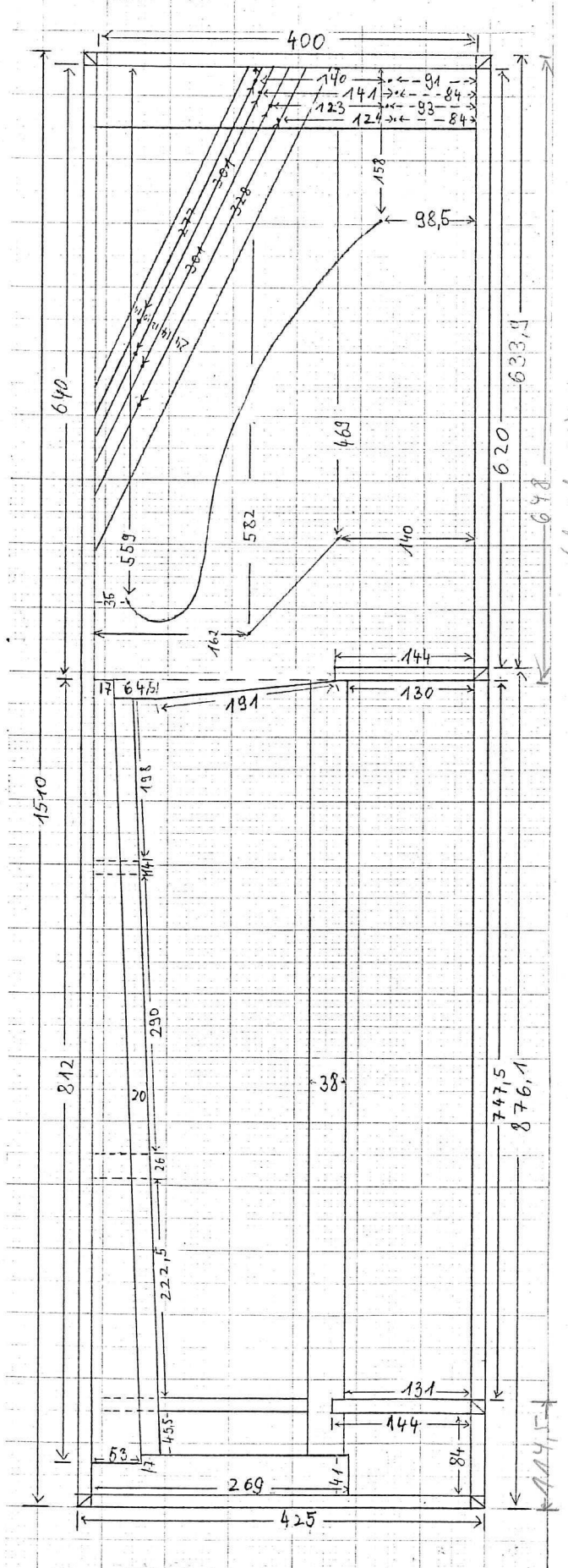
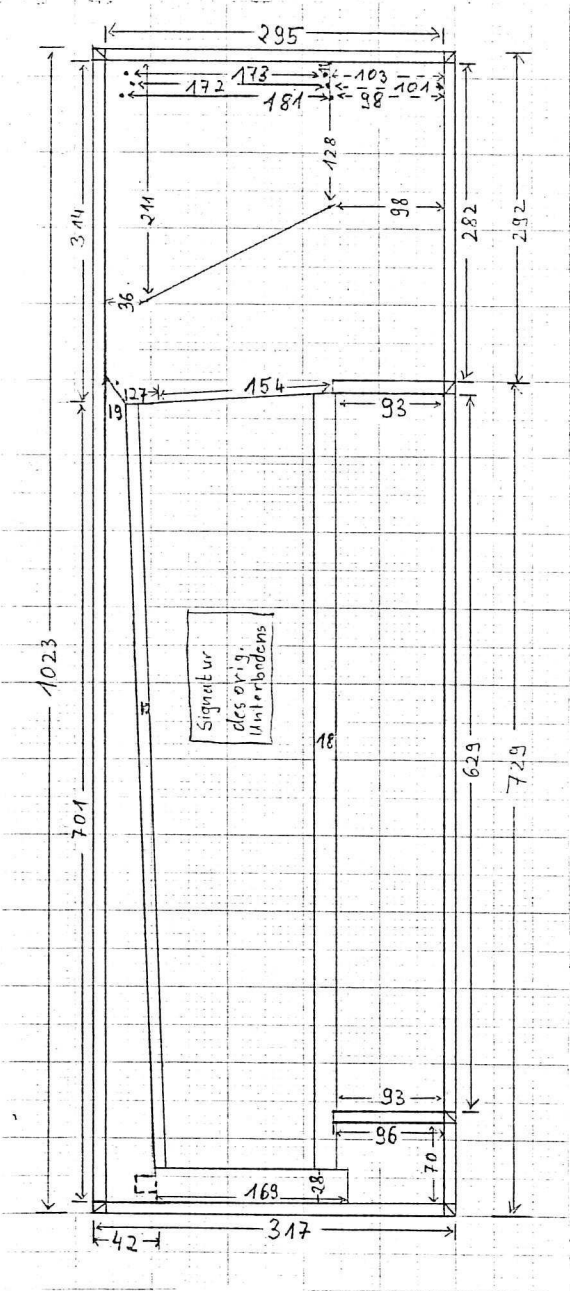

Die Wirbelreihen sind bei beiden Instrumenten jeweils 12 mm voneinander und von der Seitenwand entfernt.

Inv.Nr.5385 (Hubert)

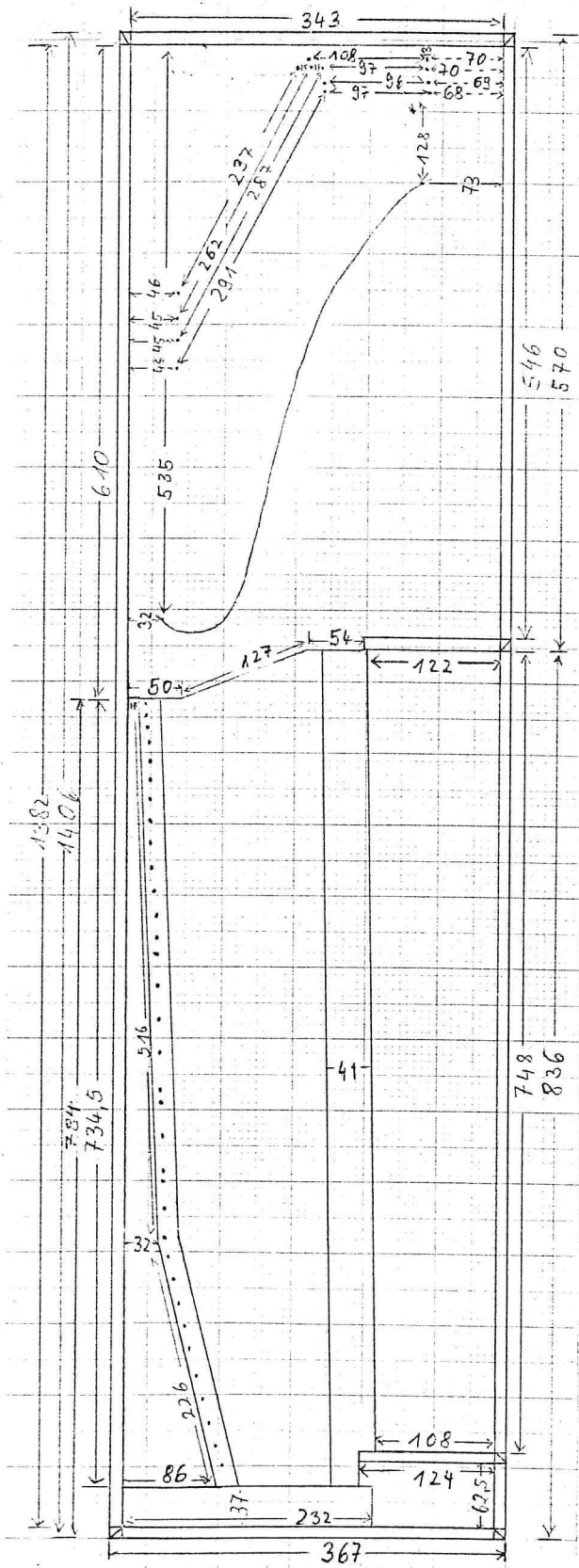

Inv.Nr.46116 (Schmahl?)

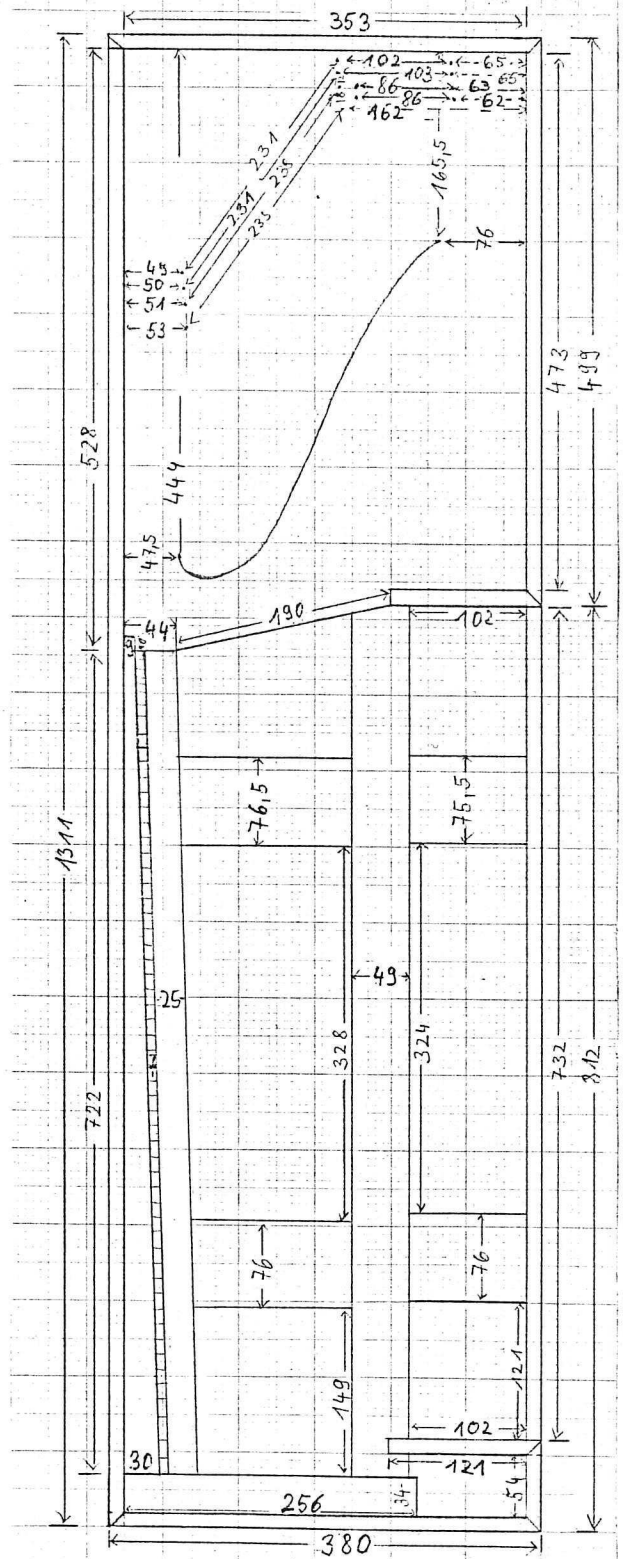

Die Wirbelreihen sind jeweils ca. 10 mm voneinander entfernt.

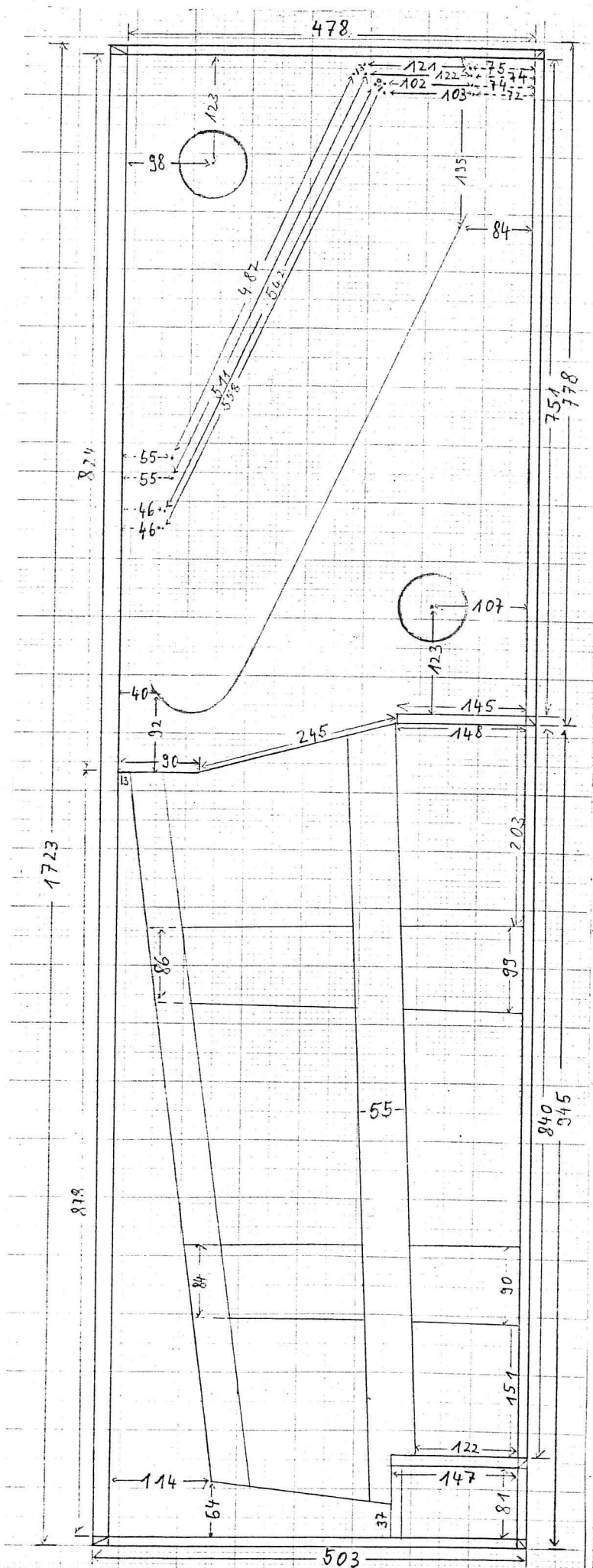

Inv.Nr.5393 (Horn)

(links)

Inv.Nr.17214 (Gebr.Schmahl)

(rechts)

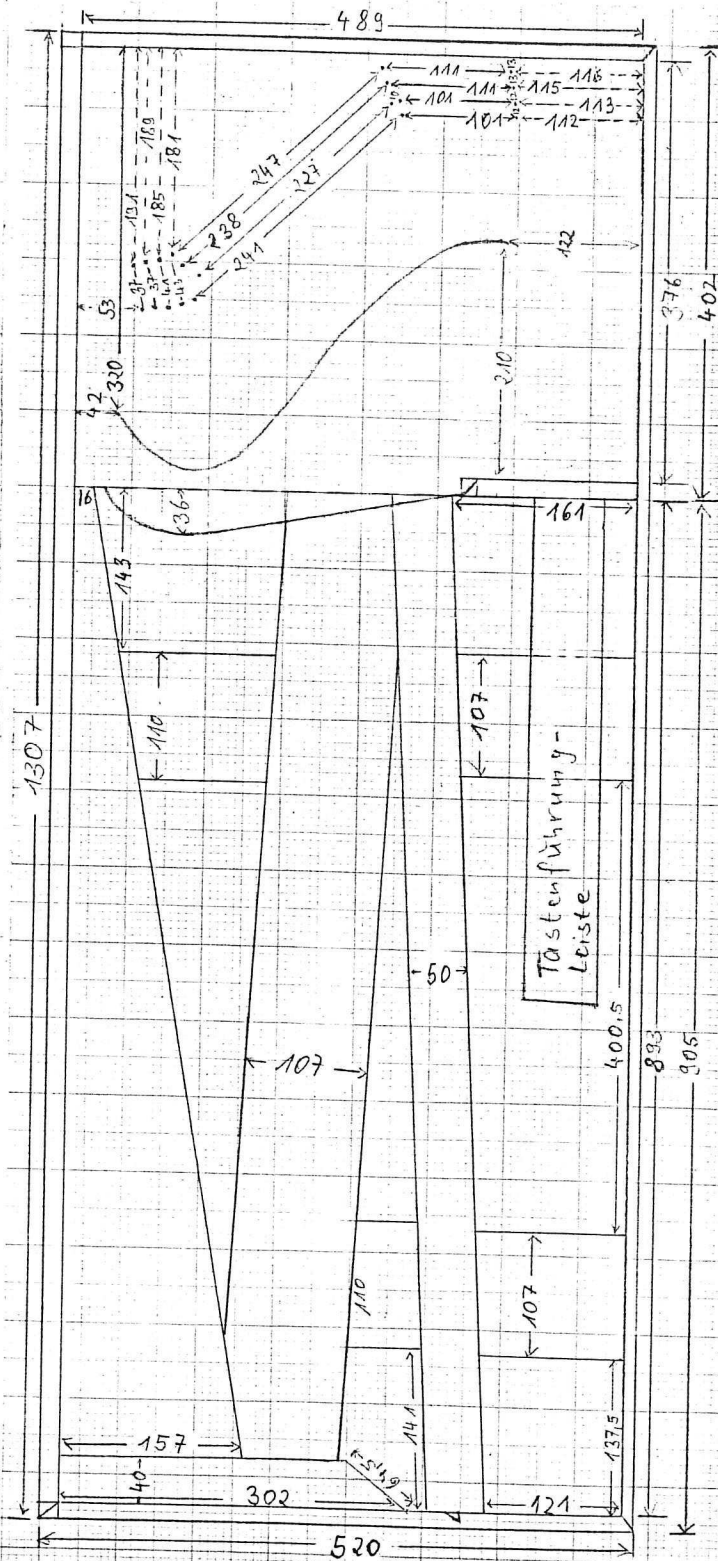

Inv.Nr.34072 (Glück?)

Pedalclavichord:

Manualclavichord:

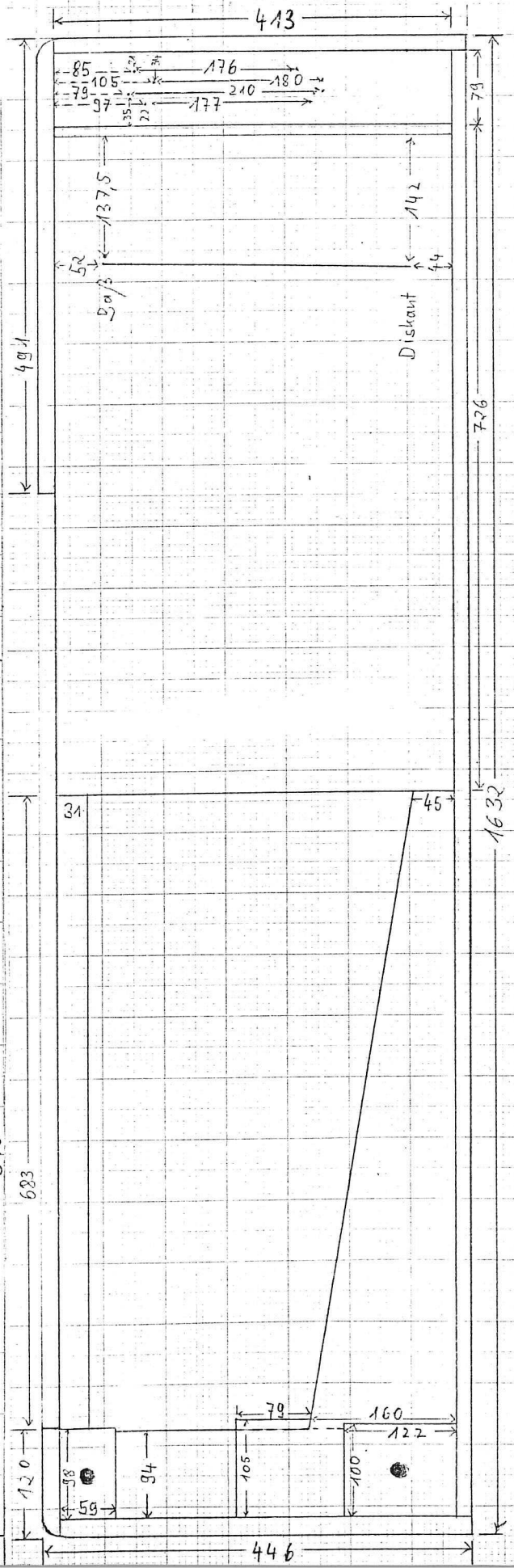
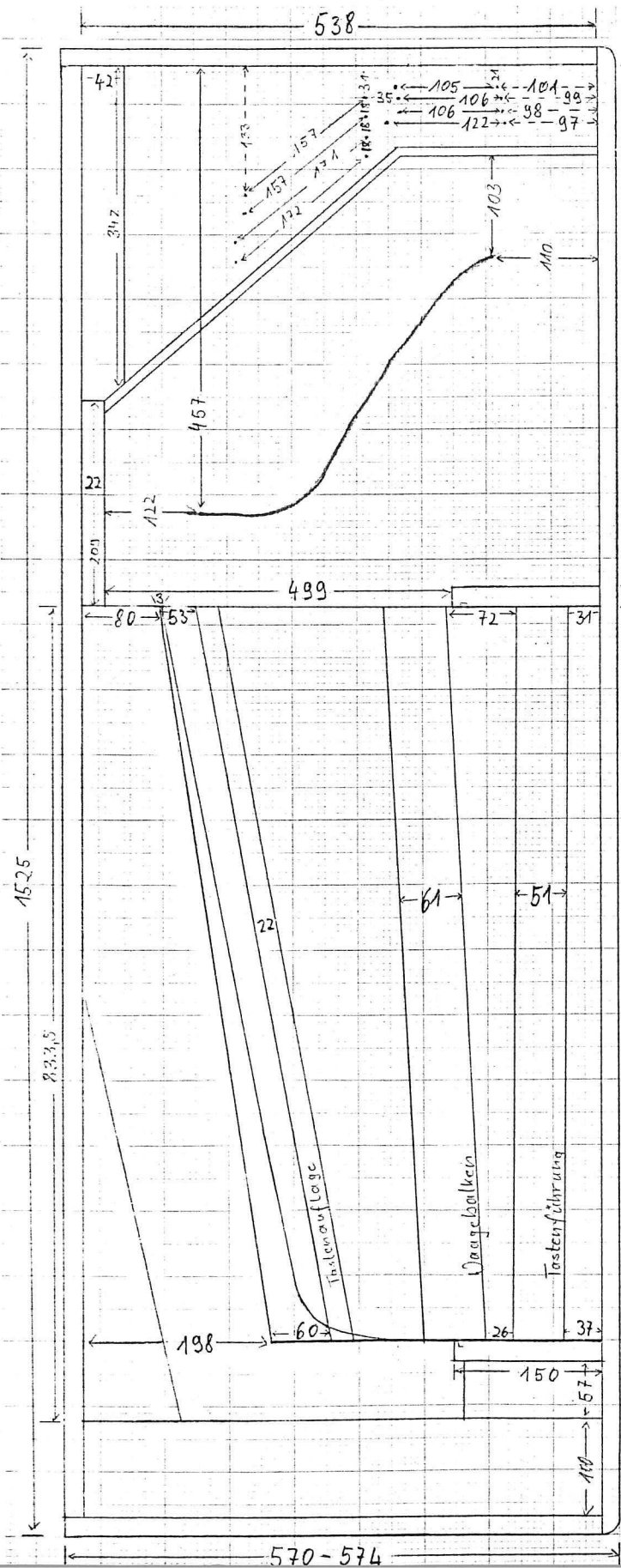

MUSIKINSTRUMENTENMUSEUM IM MÜNCHNER STADTMUSEUM

Inv.Nr. 70-103

Inv.Nr. 82-2

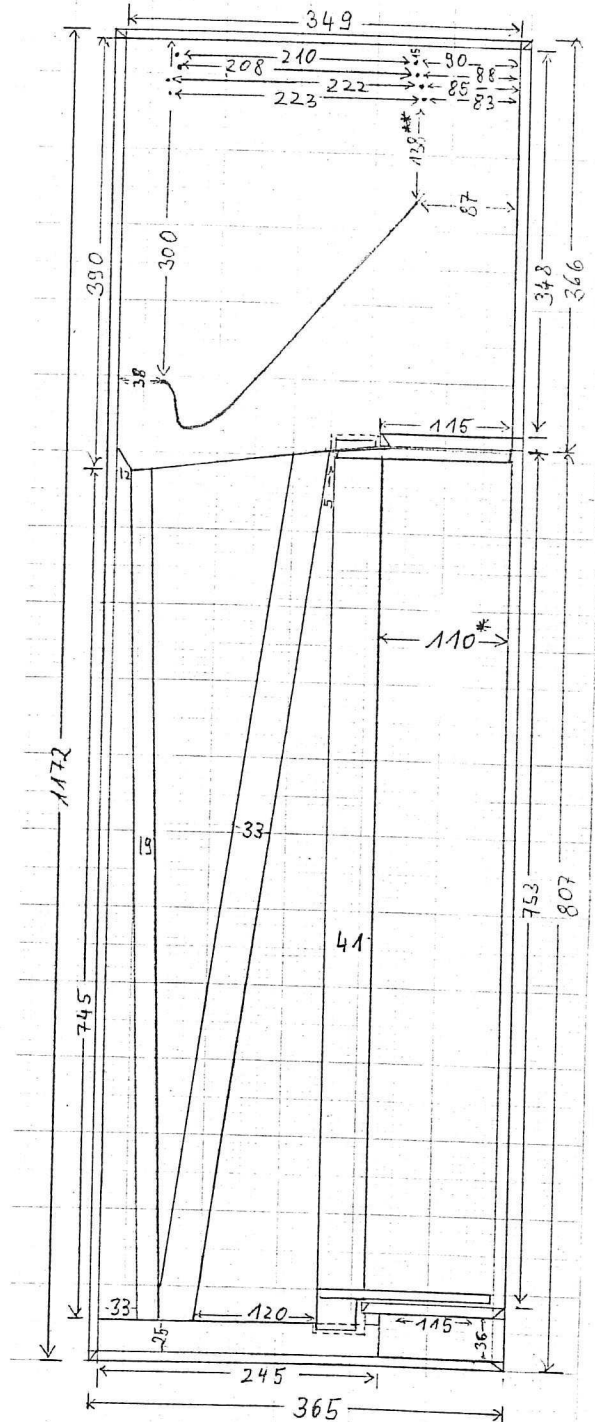
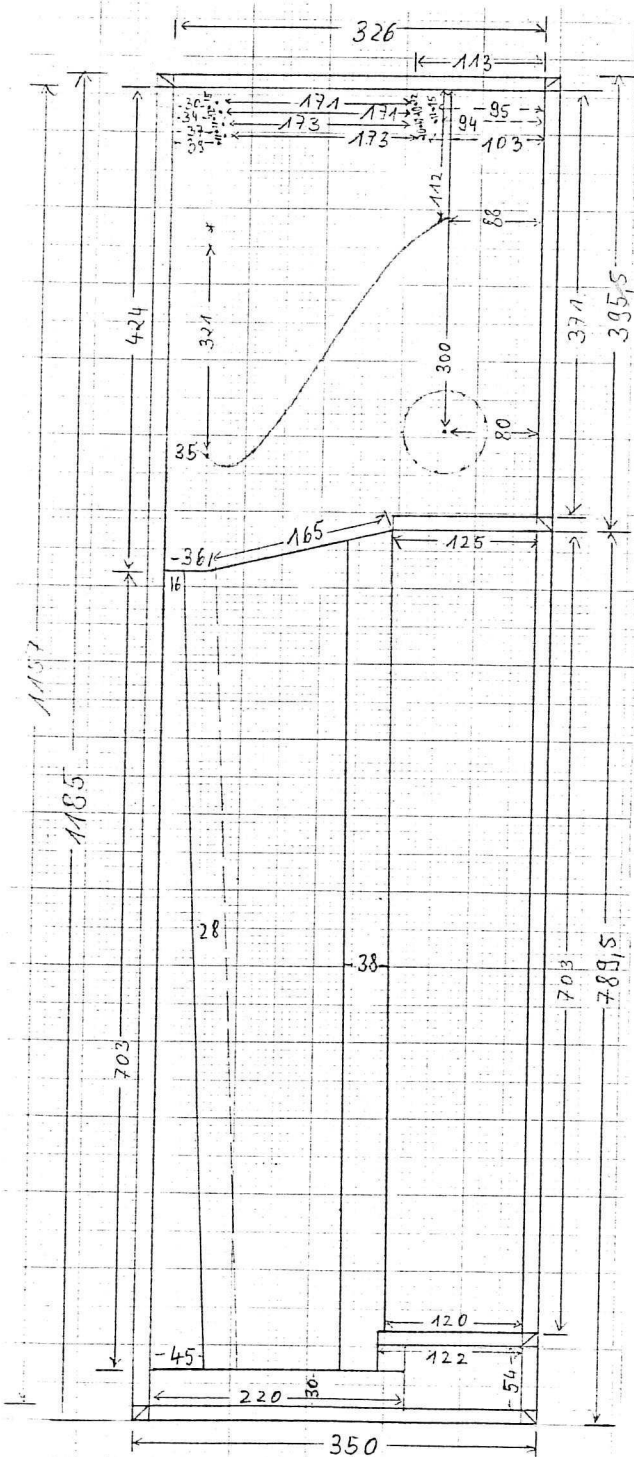

* hintere Waagebalkenposition, bei der die unbelederten Tangenteile die Saite berühren.

** bis zur rechten Seitenwand.

Die Wirbelreihen sind ca. 10 mm voneinander entfernt.

Inv.Nr. 69-15

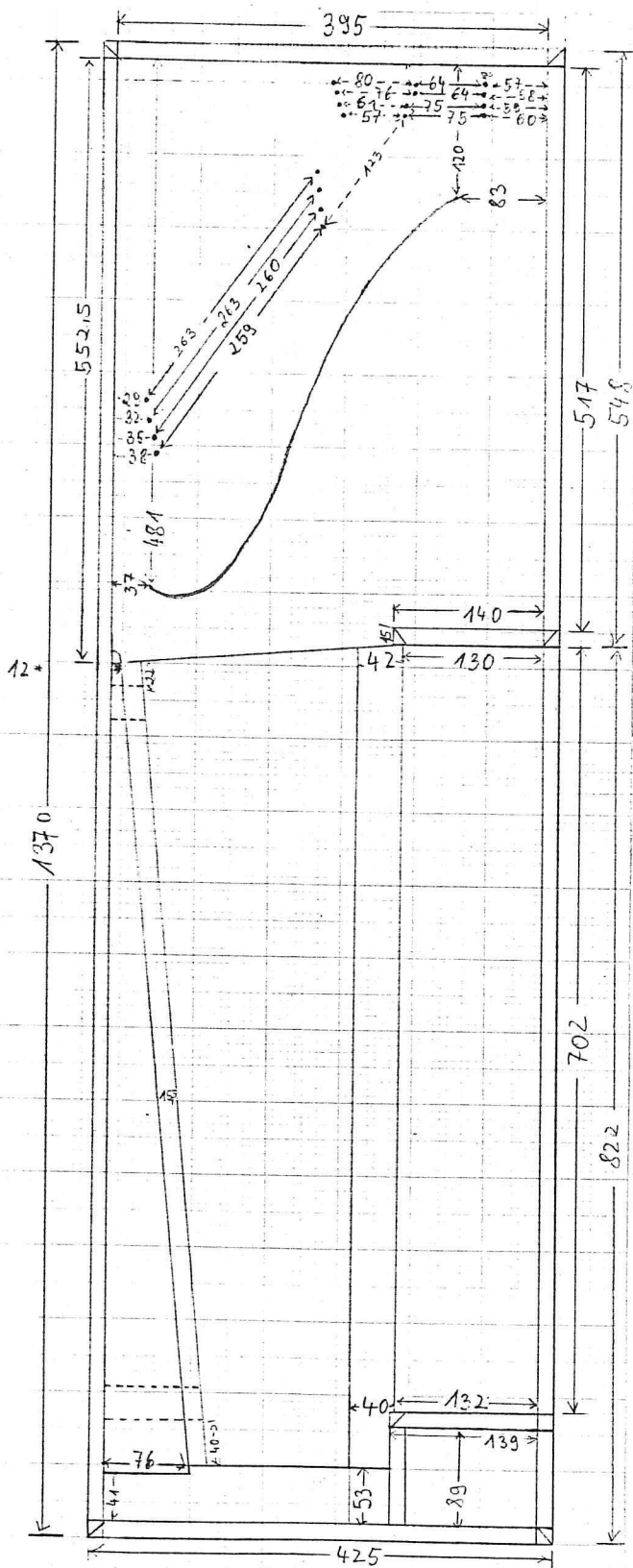

Die Wirbelreihen sind 12 mm voneinander entfernt.

Die Pfeile des schrägen Wirbelfelds zeigen die Markierungsrisse an. Sie sind ca. 13 mm voneinander entfernt.

Inv.Nr. 44-1

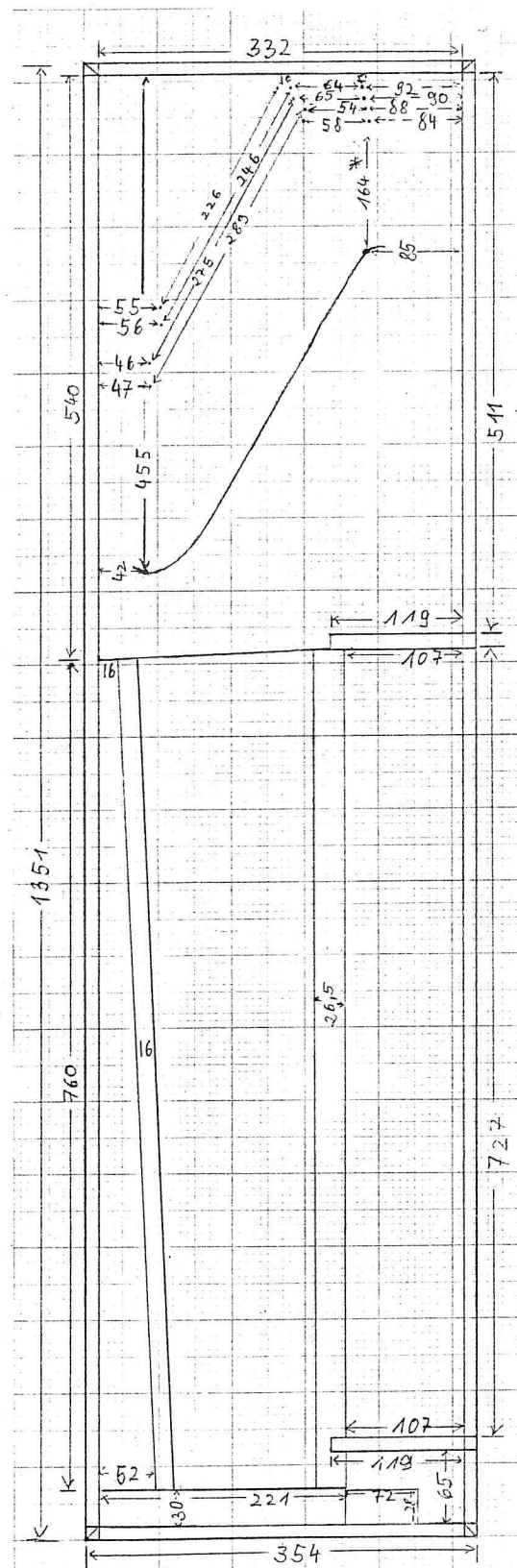

Die Wirbelreihen sind 10 mm voneinander entfernt.

* bis zur rechten Seitenwand.

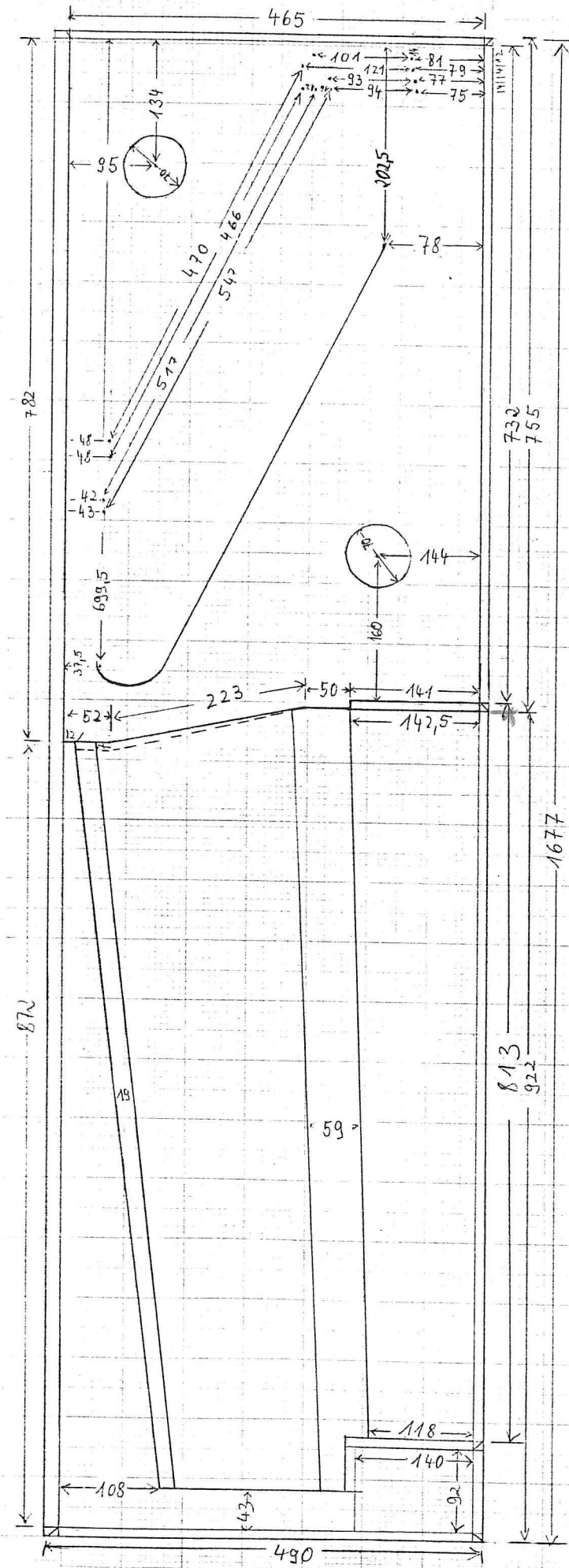

Inv.Nr.44-2 (Horn?) (links)

Inv.Nr.44-3 (rechts)

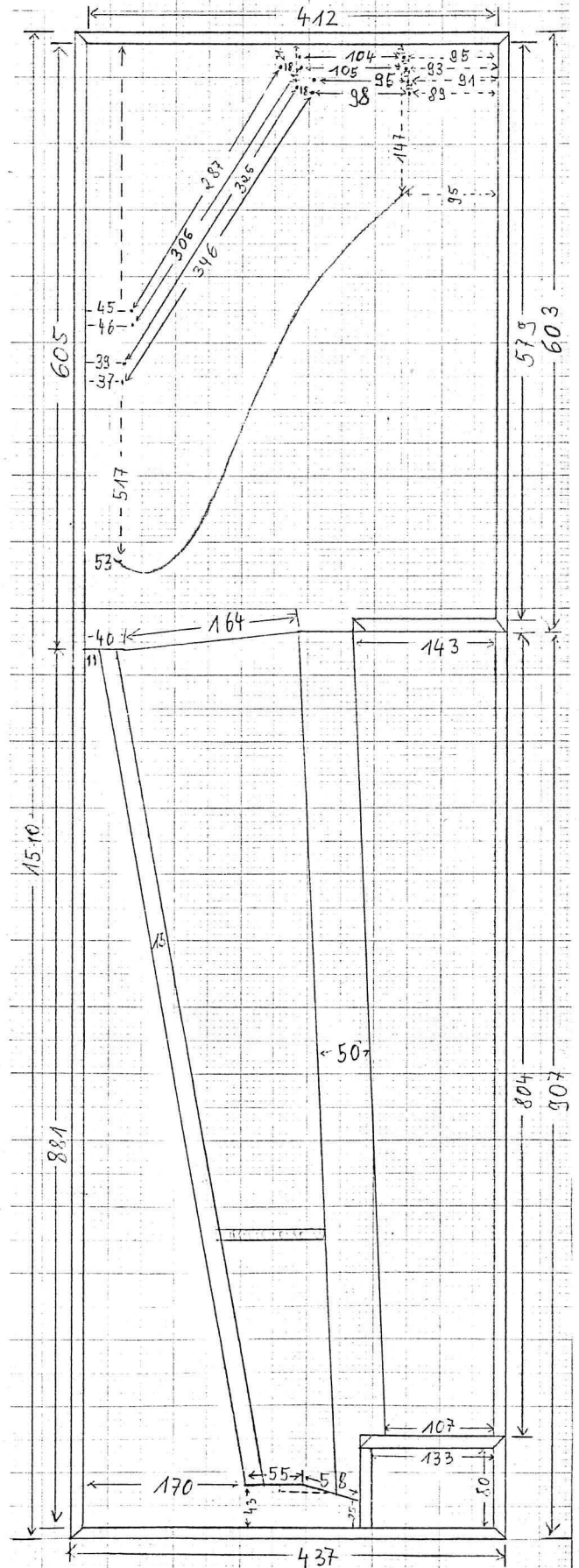

Inv.Nr.44-4

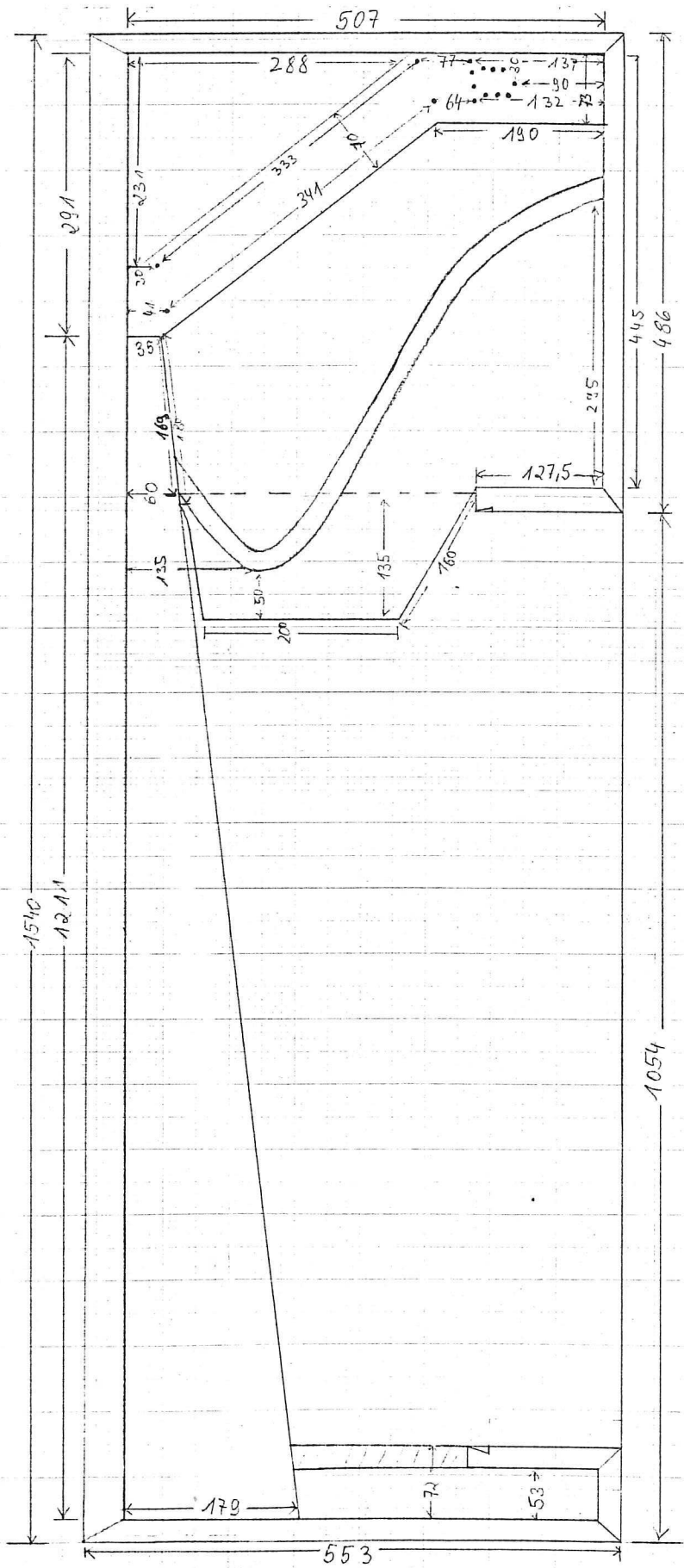

Reiseclavichord, Staatsbibliothek, München

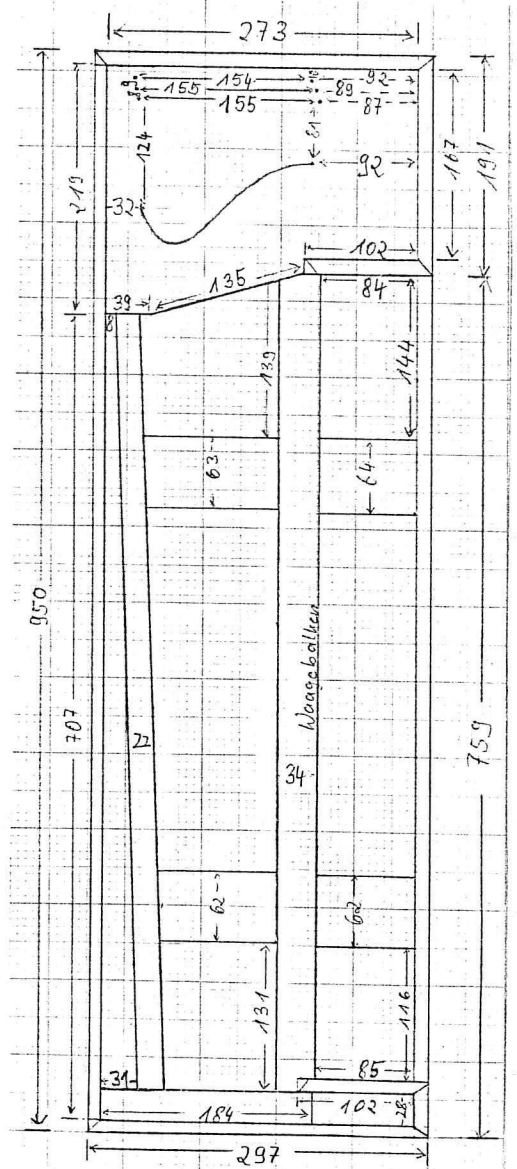

BAYERISCHES NATIONALMUSEUM, MÜNCHEN

Inv.Nr.28/1818

Inv.Nr.Mu 72 (Schmahl)

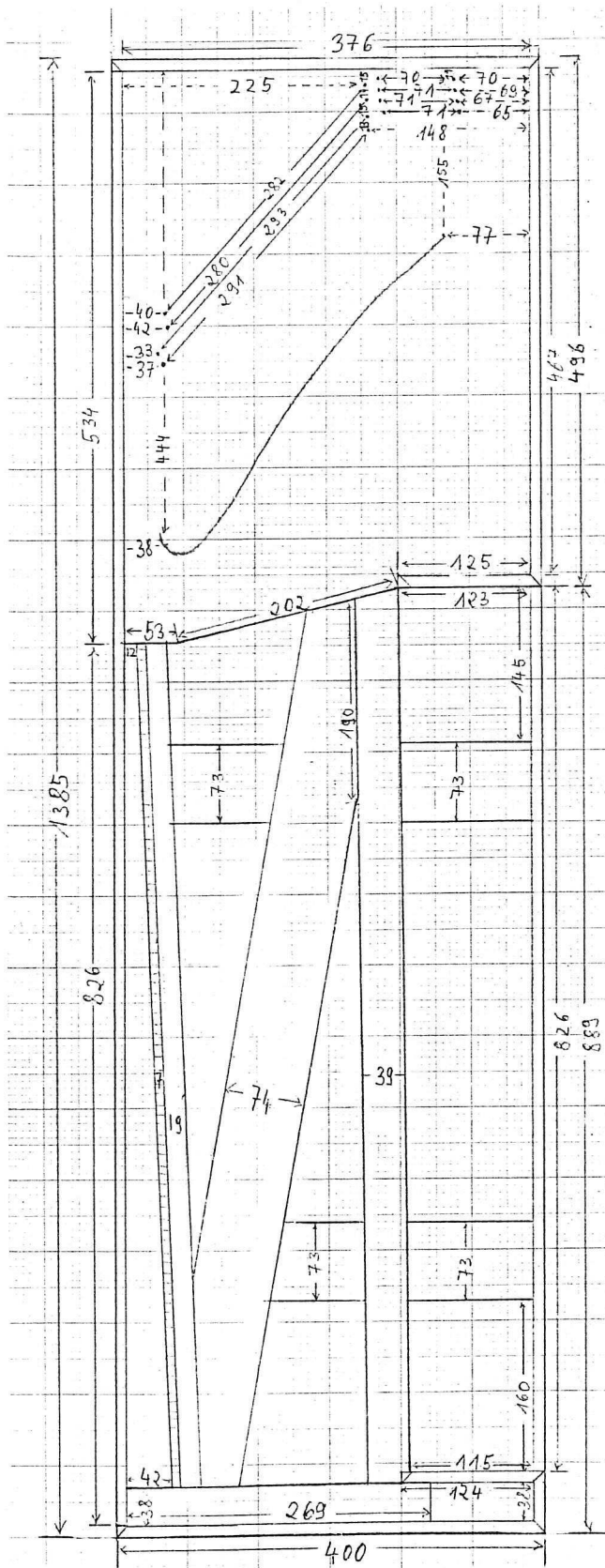
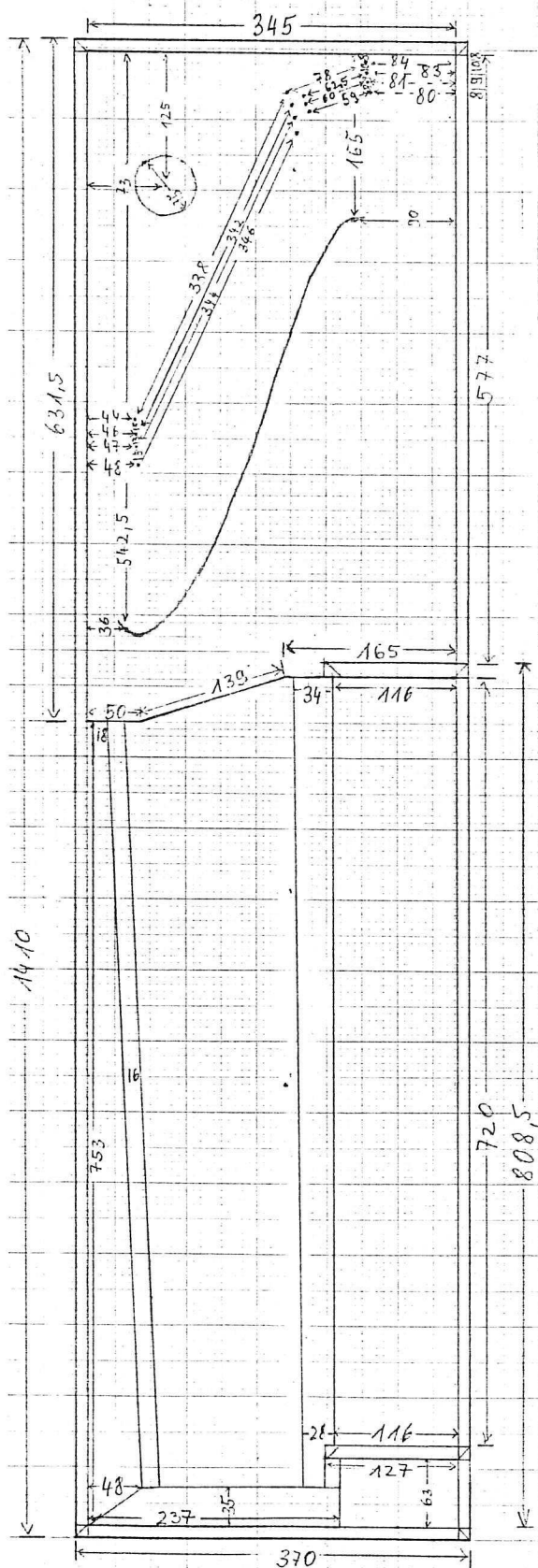

Die Wirbelreihen sind jeweils 11 mm voneinander entfernt.

WÜRTTEMBERGISCHES LANDESMUSEUM STUTTGART

Inv.Nr. G 4111 (Schiedmayer)

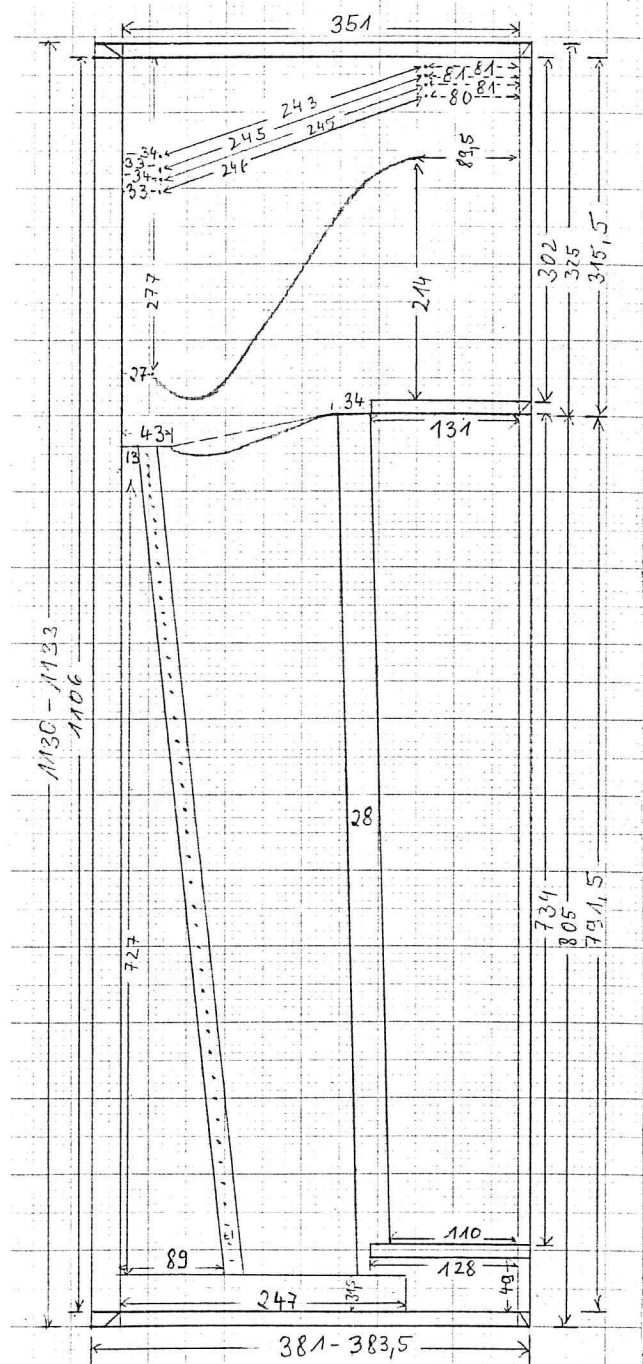

Die Wirbelreihen sind jeweils ca. 10 mm voneinander entfernt.

III. MENSURKURVEN

DEUTSCHES MUSEUM, MÜNCHEN

Inv.Nr.18165

Inv.Nr.5392 (Weiss)

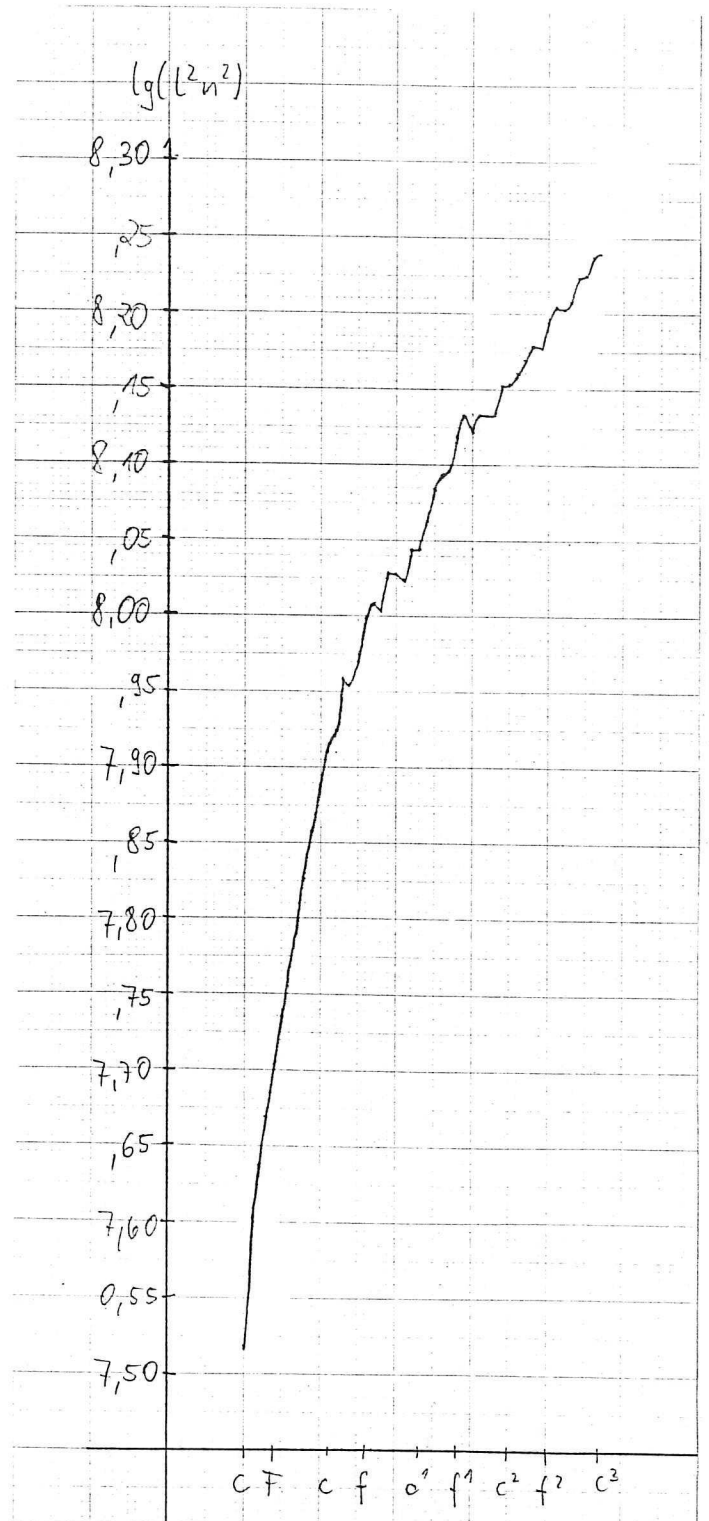
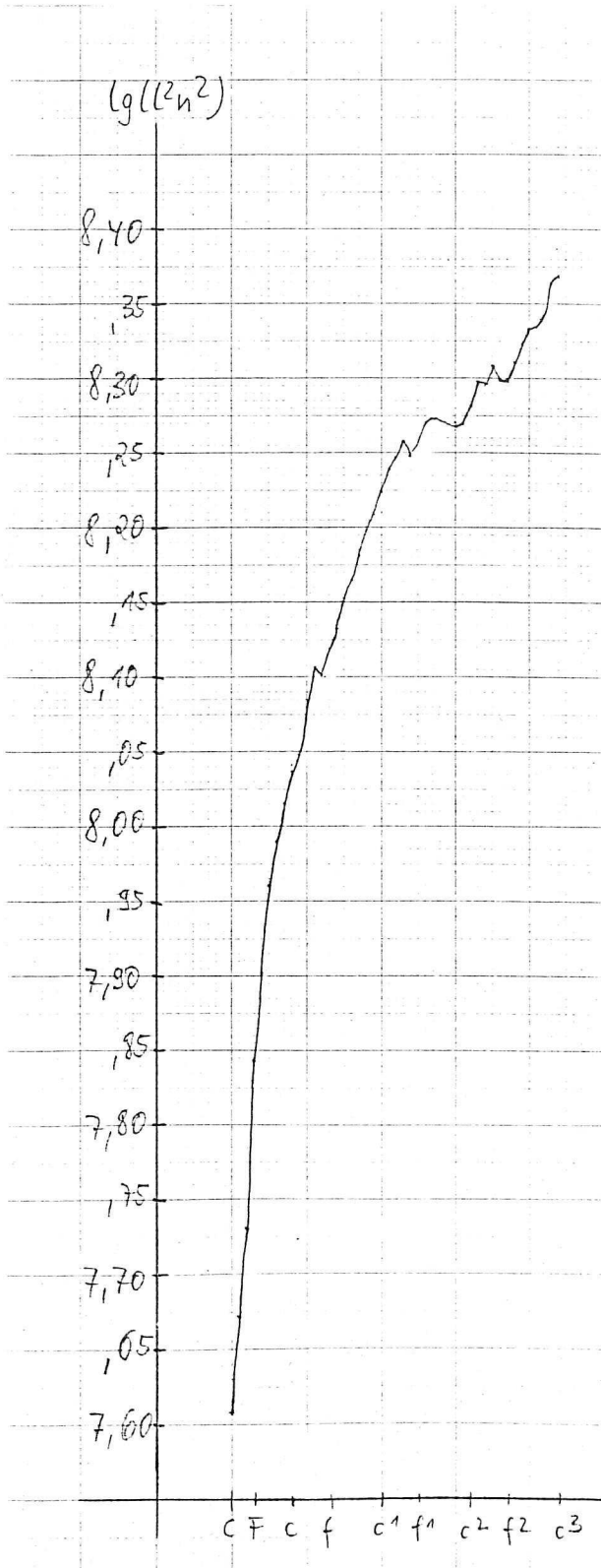

Inv.Nr.16816 (König)

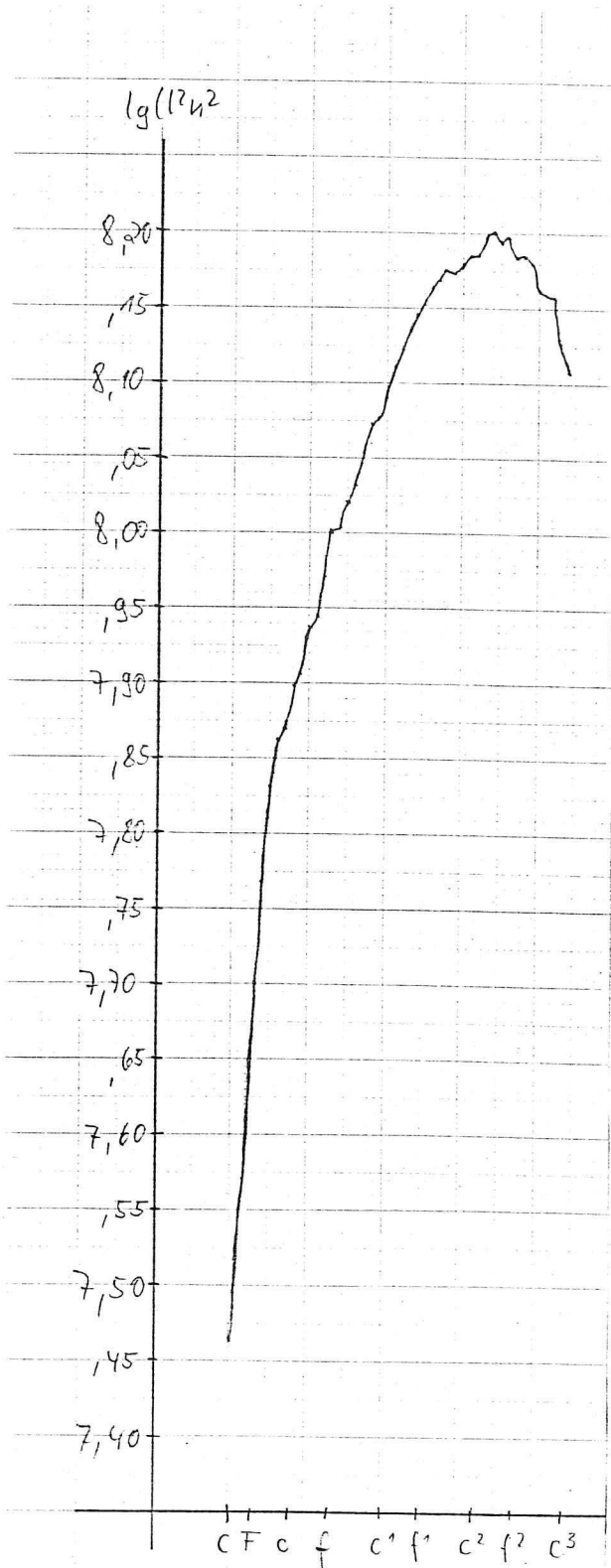

Inv.Nr.20780 (Lemme)

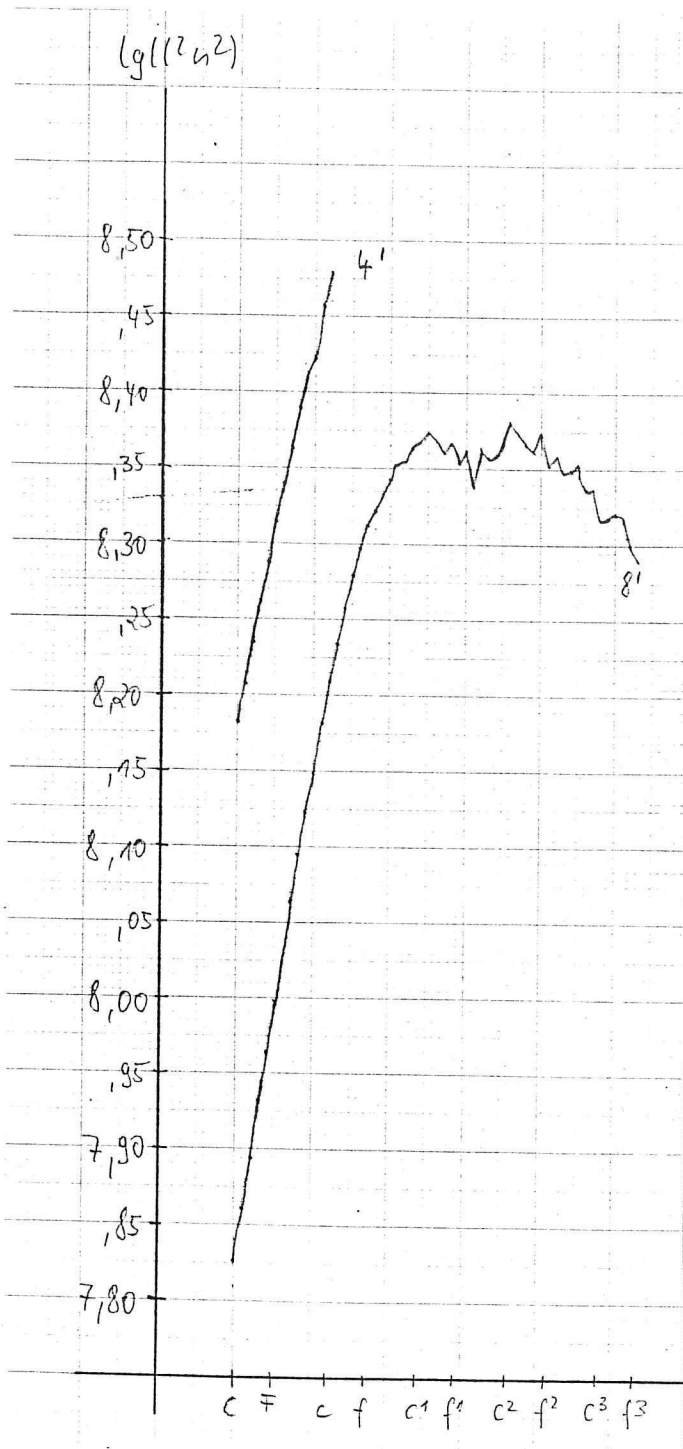

Inv.Nr.5385 (Hubert)

Inv.Nr.46116 (Schmahl?)

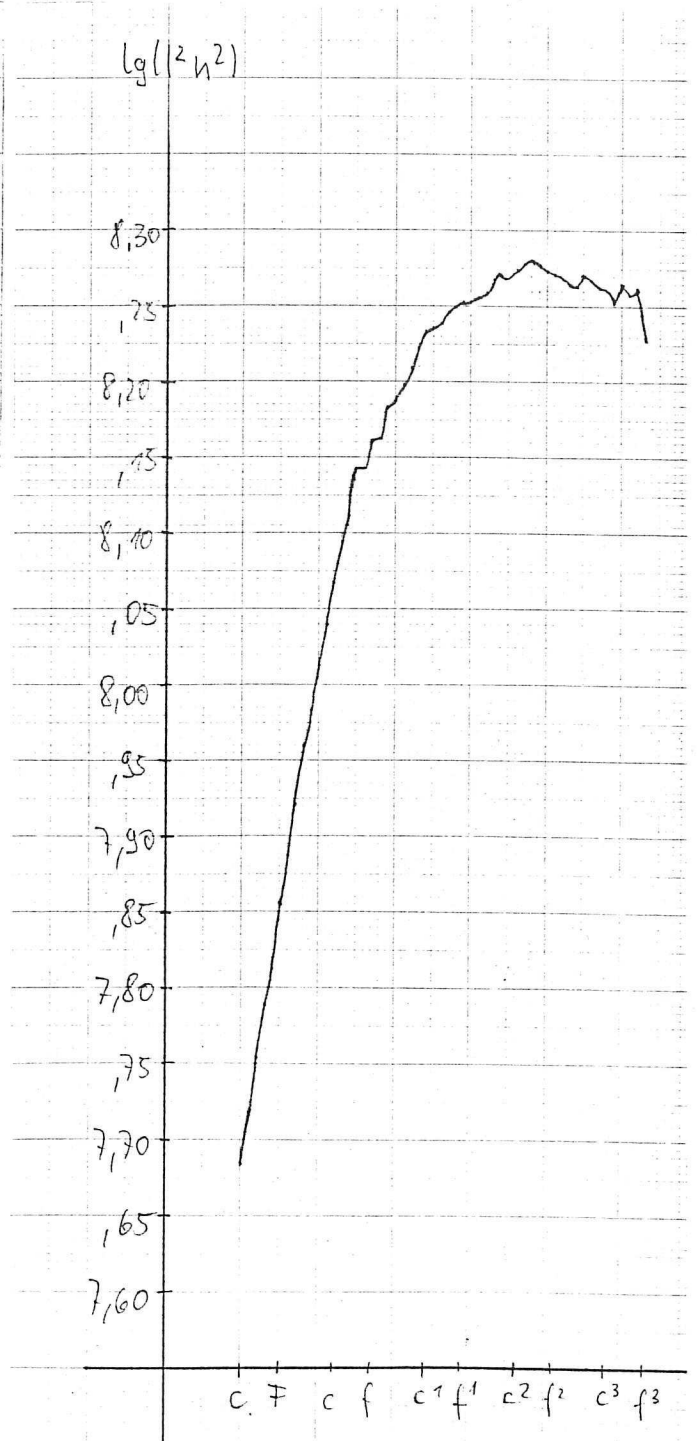
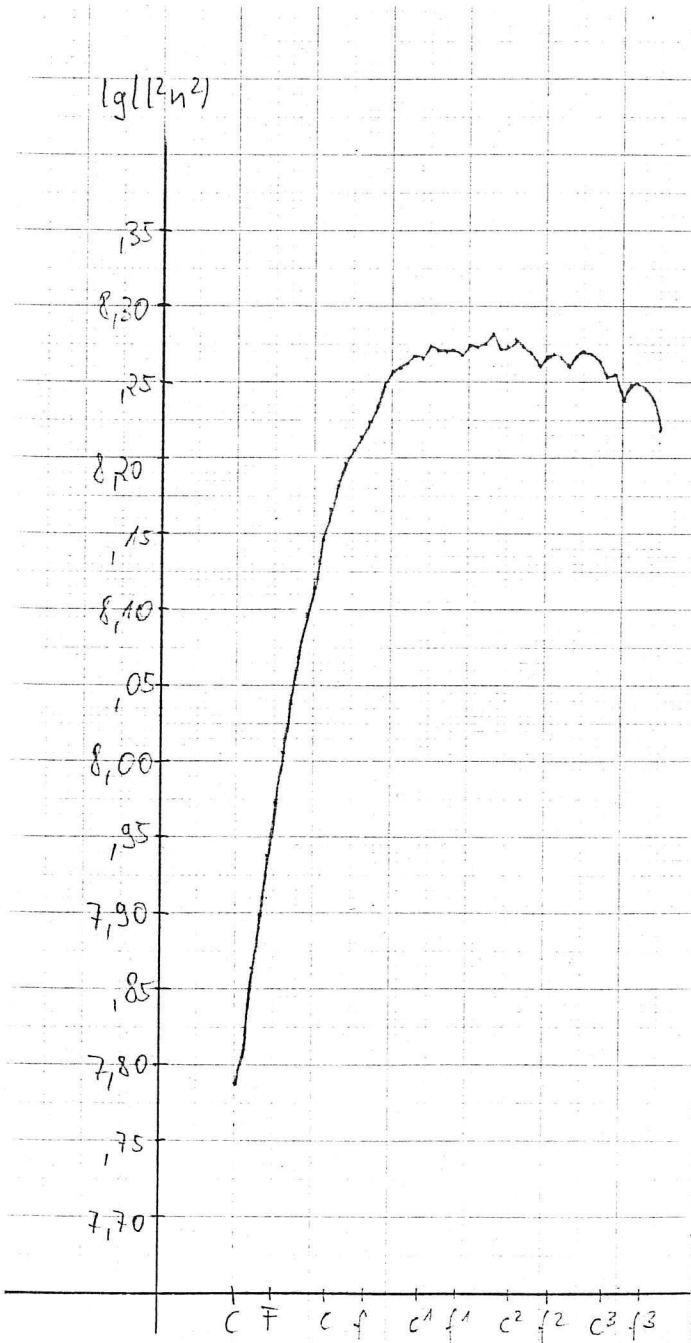

Inv.Nr.5393 (Horn)

Inv.Nr.17214 (Gebr.Schmahl)

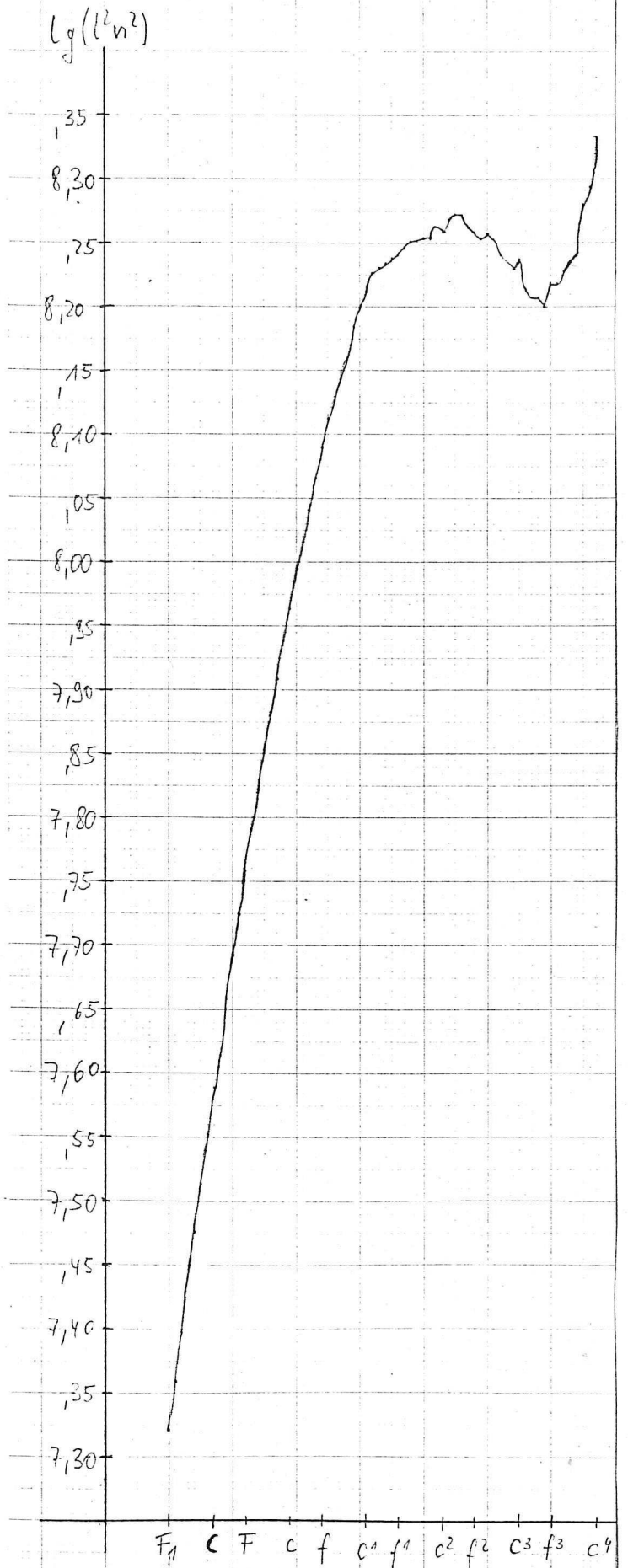
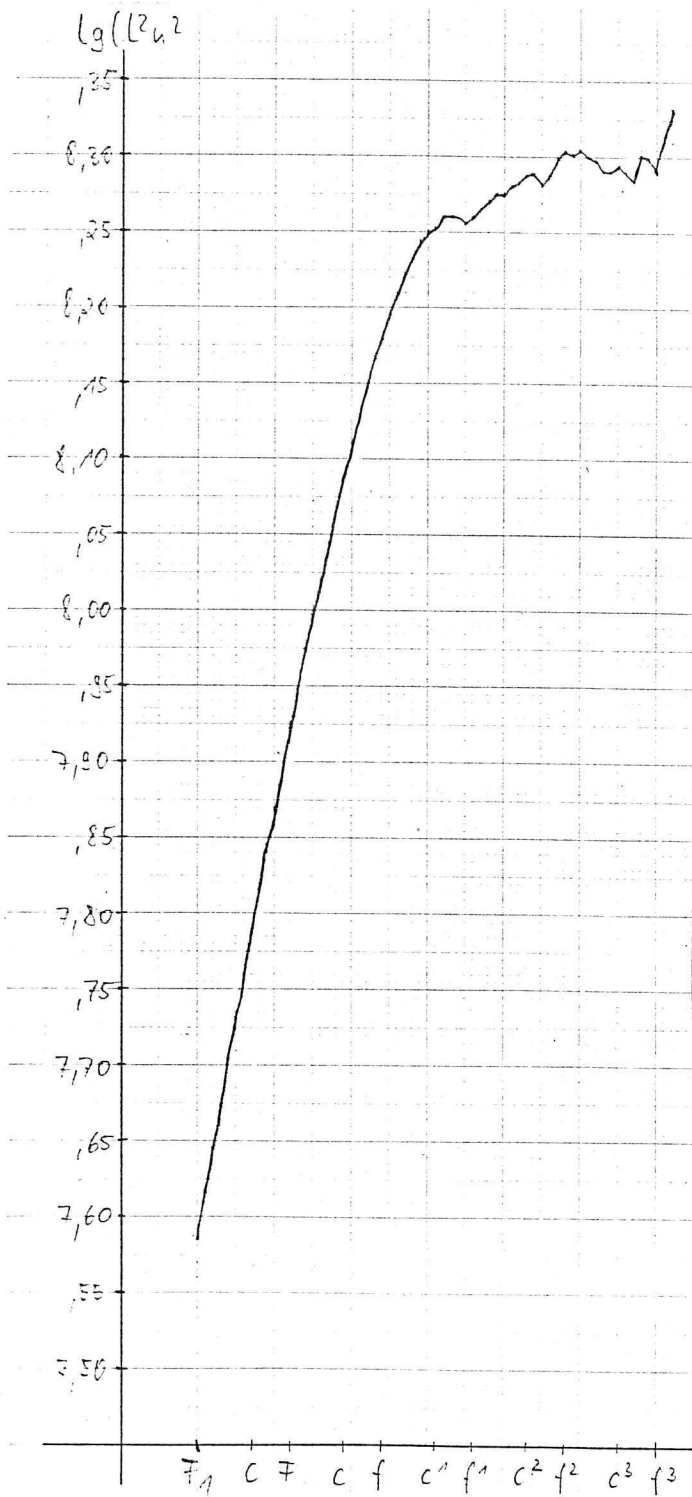

Inv.Nr.34072 (Glück?)

Manualclavichord:

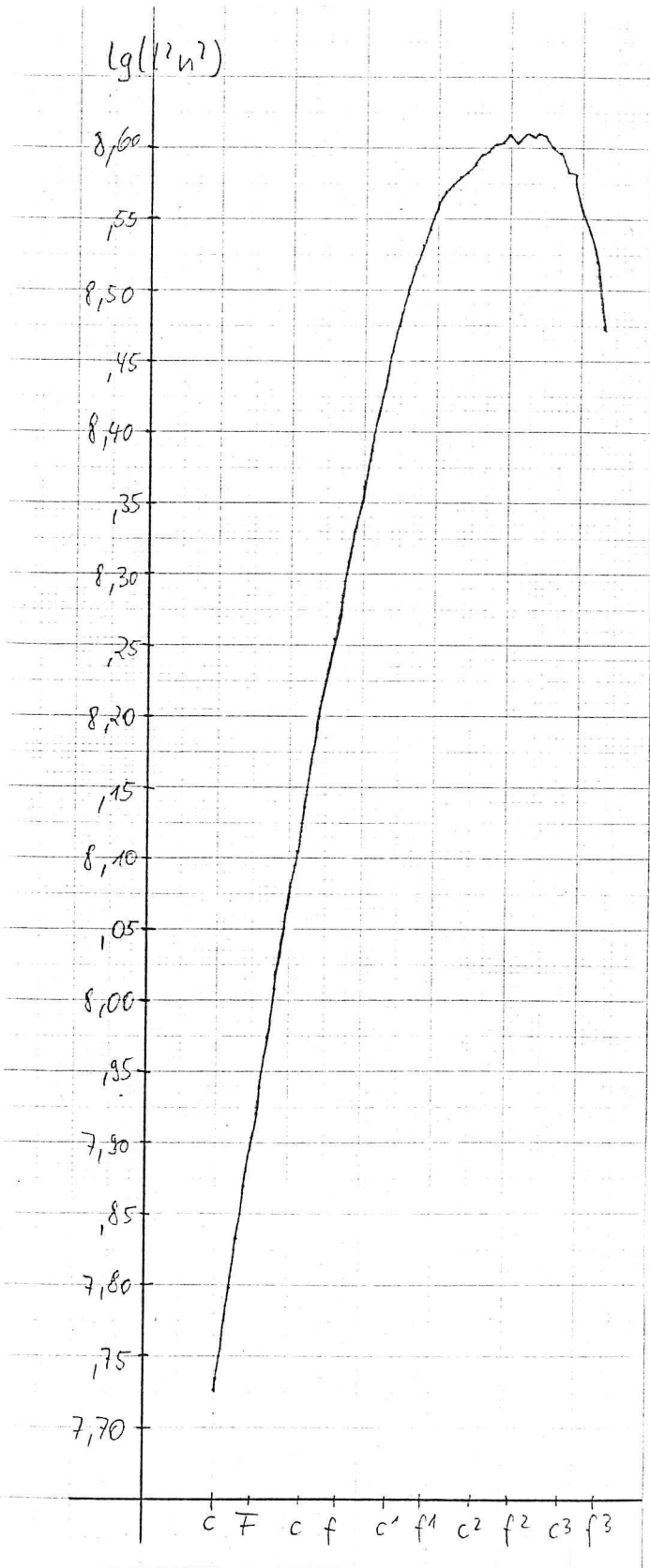

Pedalclavichord:

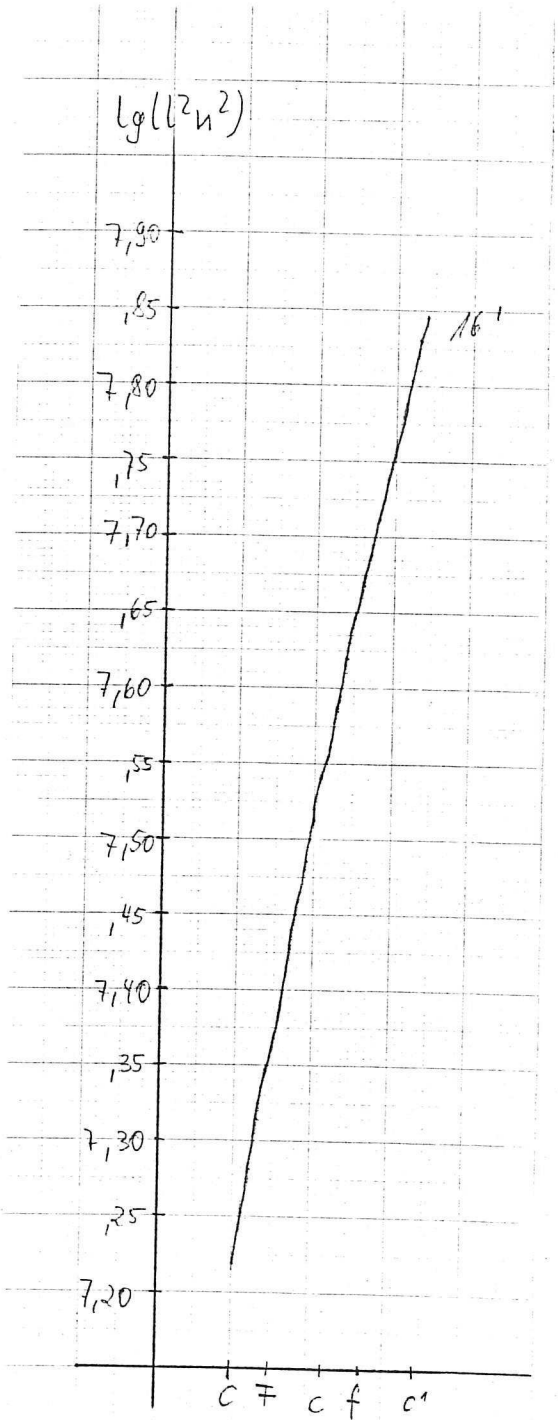

MUSIKINSTRUMENTENMUSEUM IM MÜNCHNER STADTMUSEUM

Inv.Nr.70-103

Inv.Nr.82-2

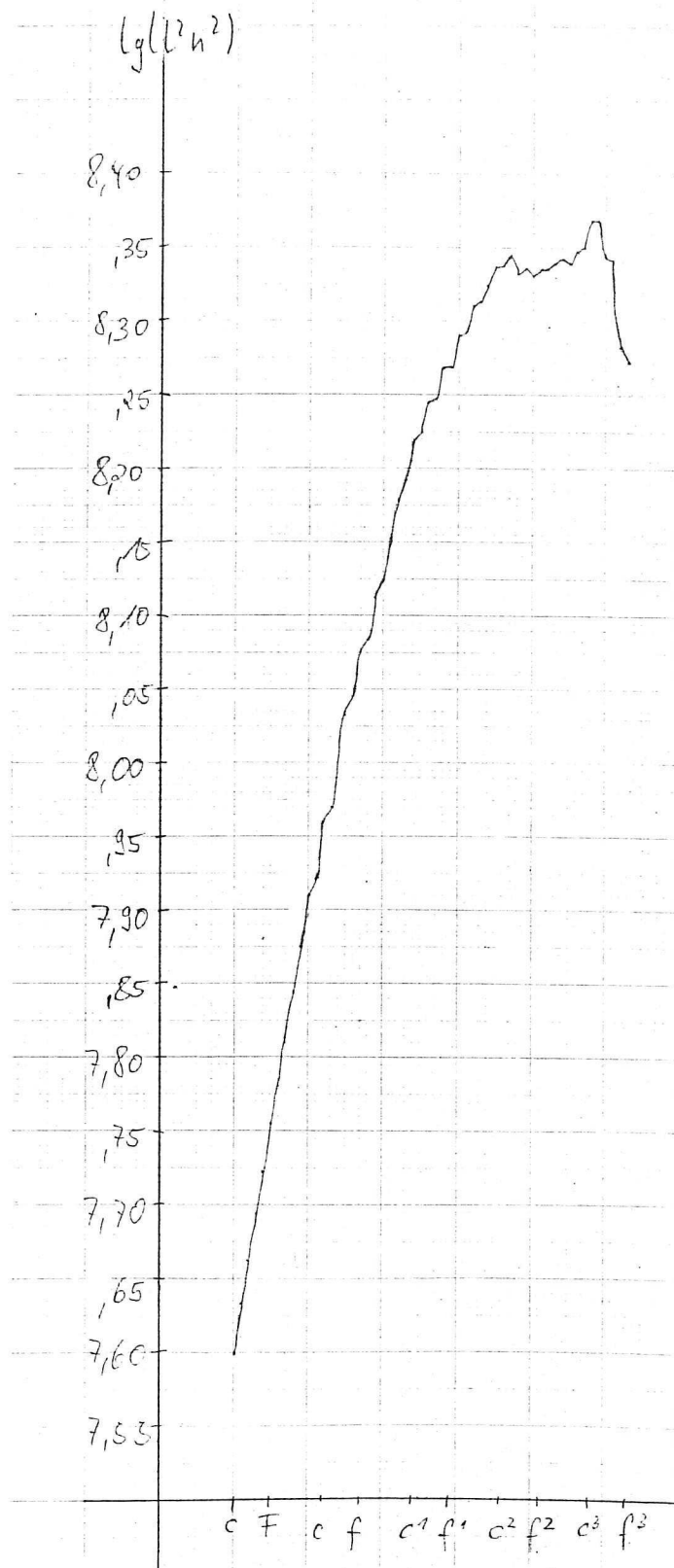
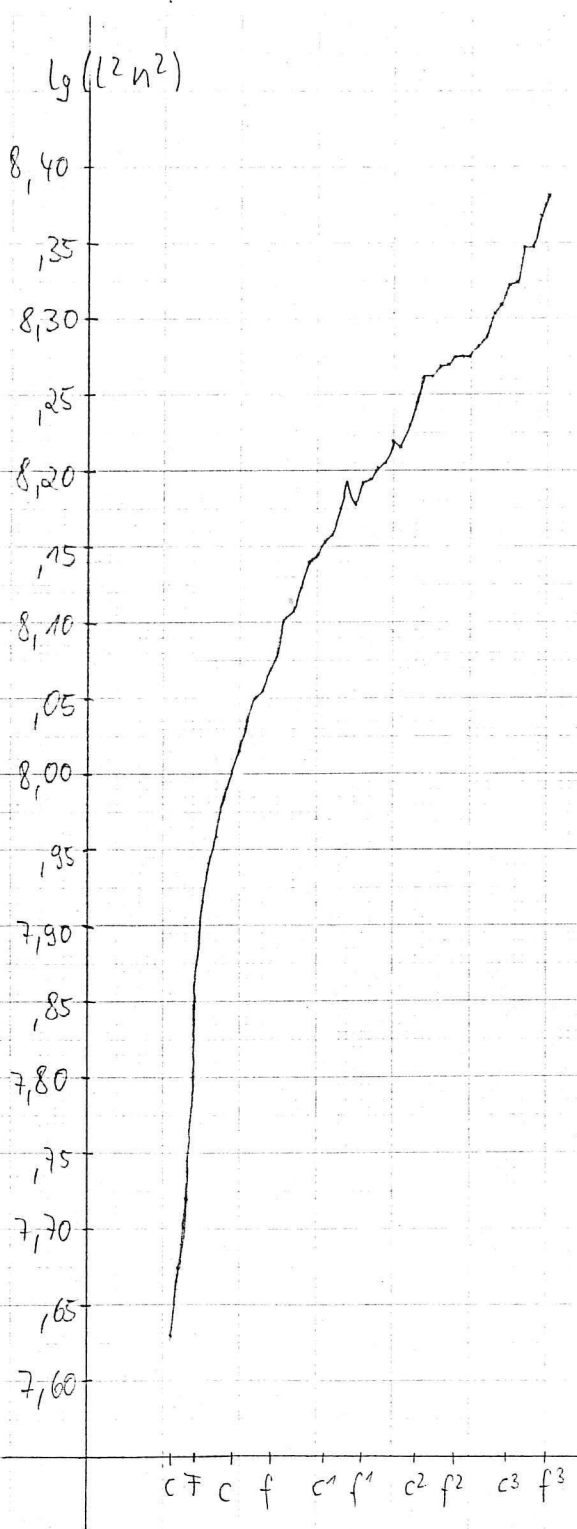

Inv.Nr.69-15

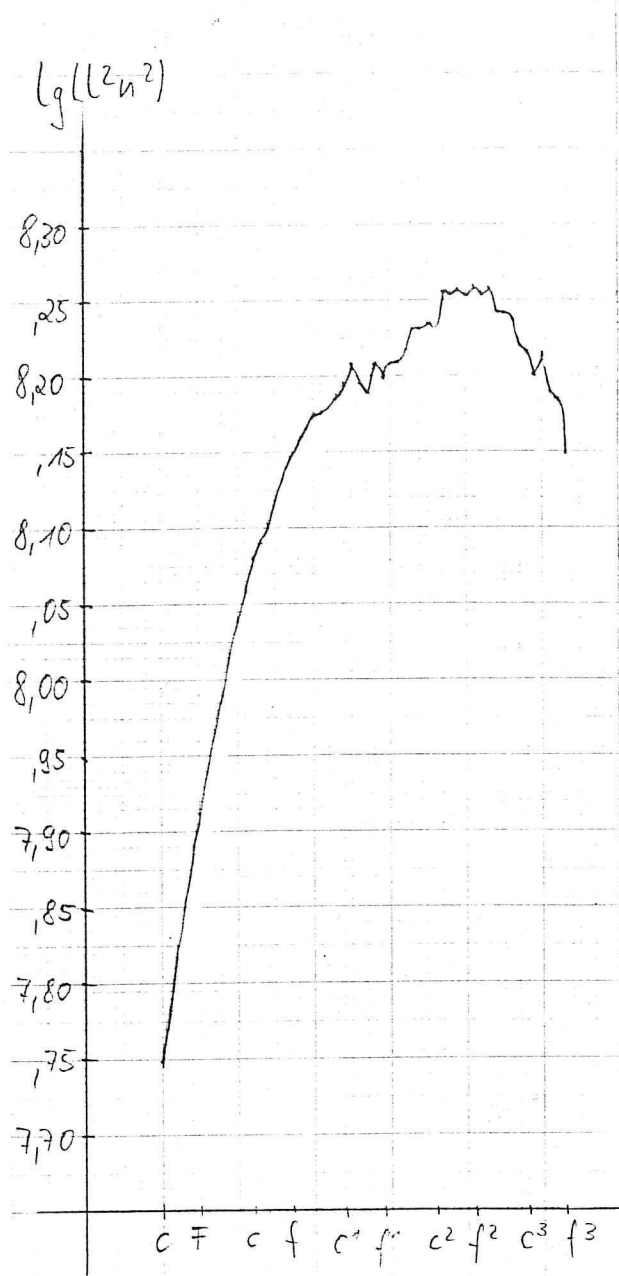

Inv.Nr.44-1

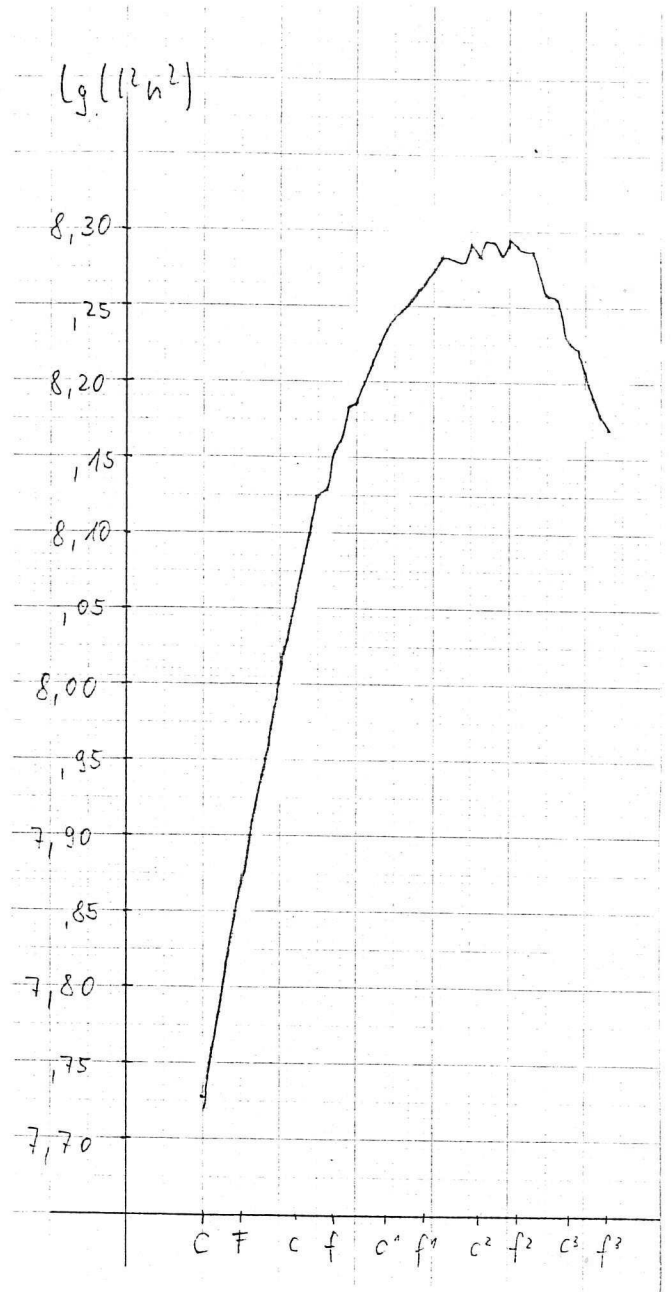

Inv.Nr.44-2 (Horn?)

Inv.Nr.44-3

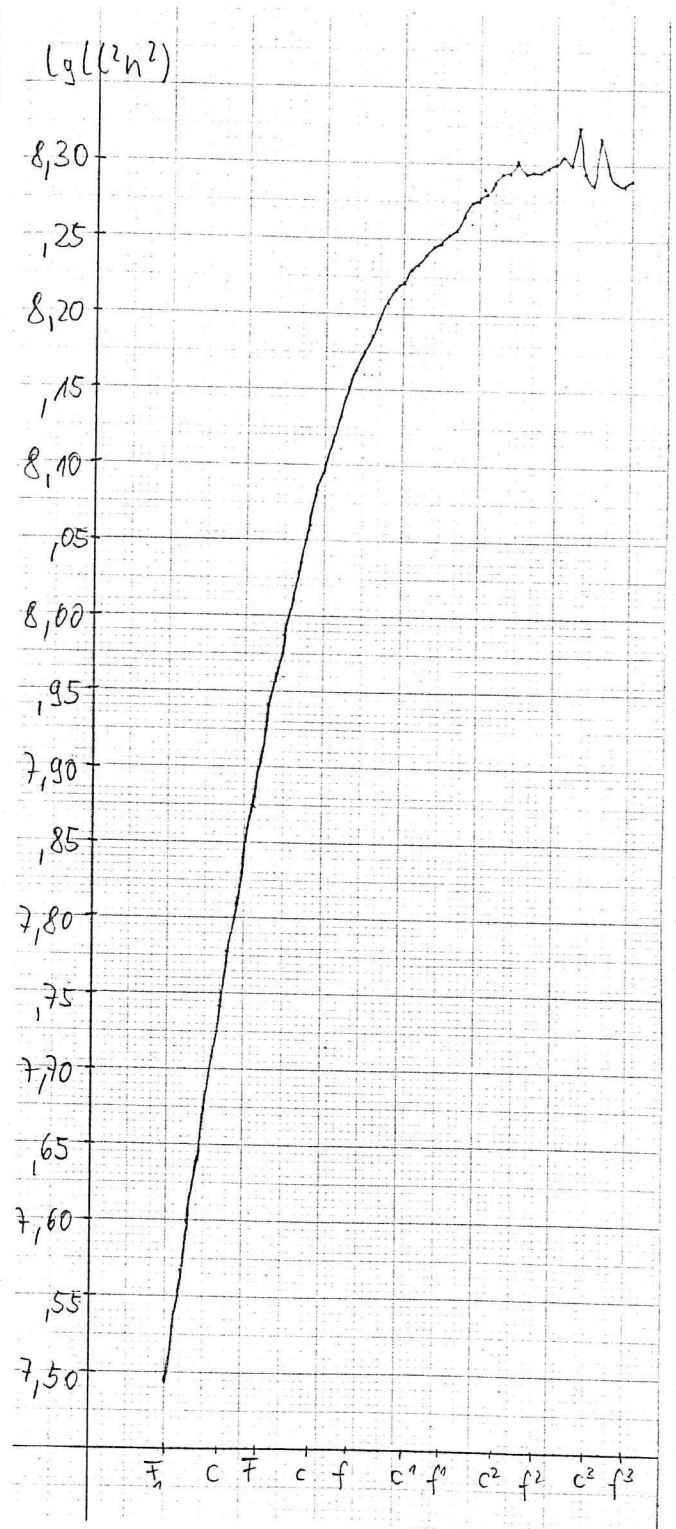
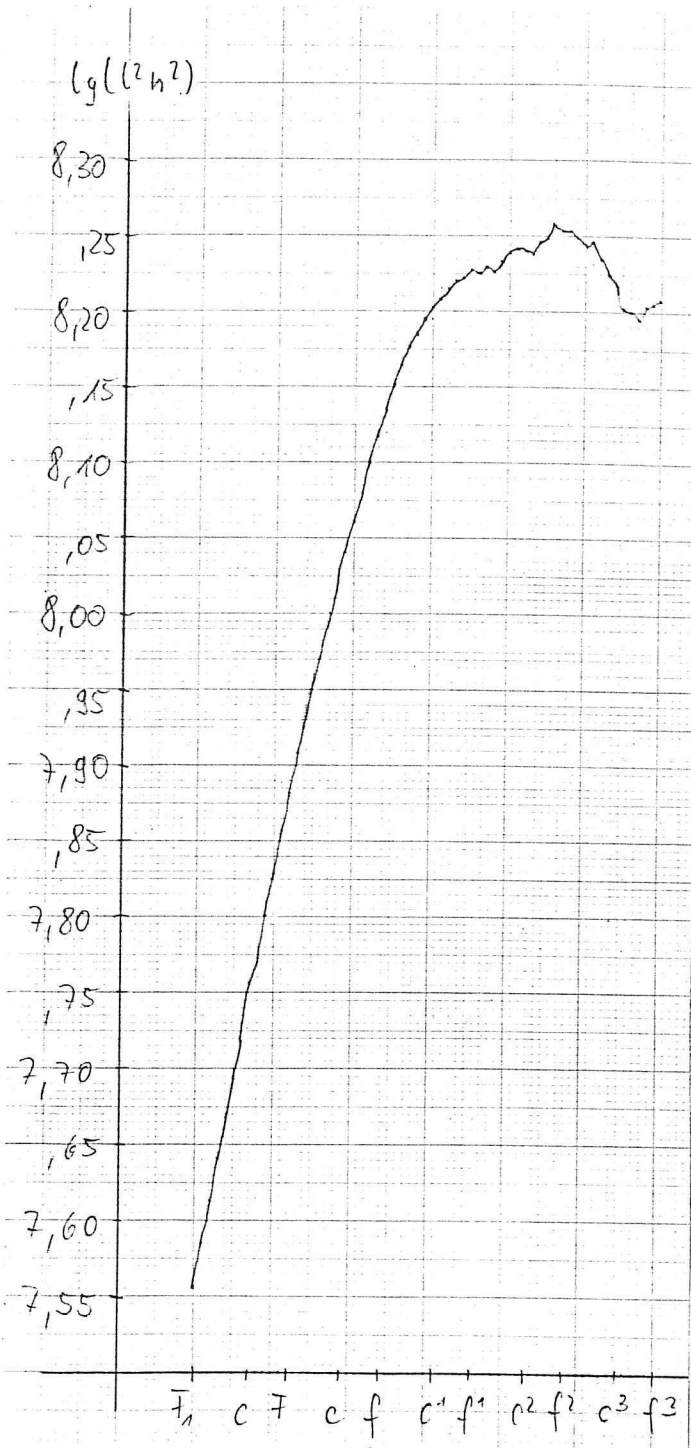

Inv.Nr.44-4

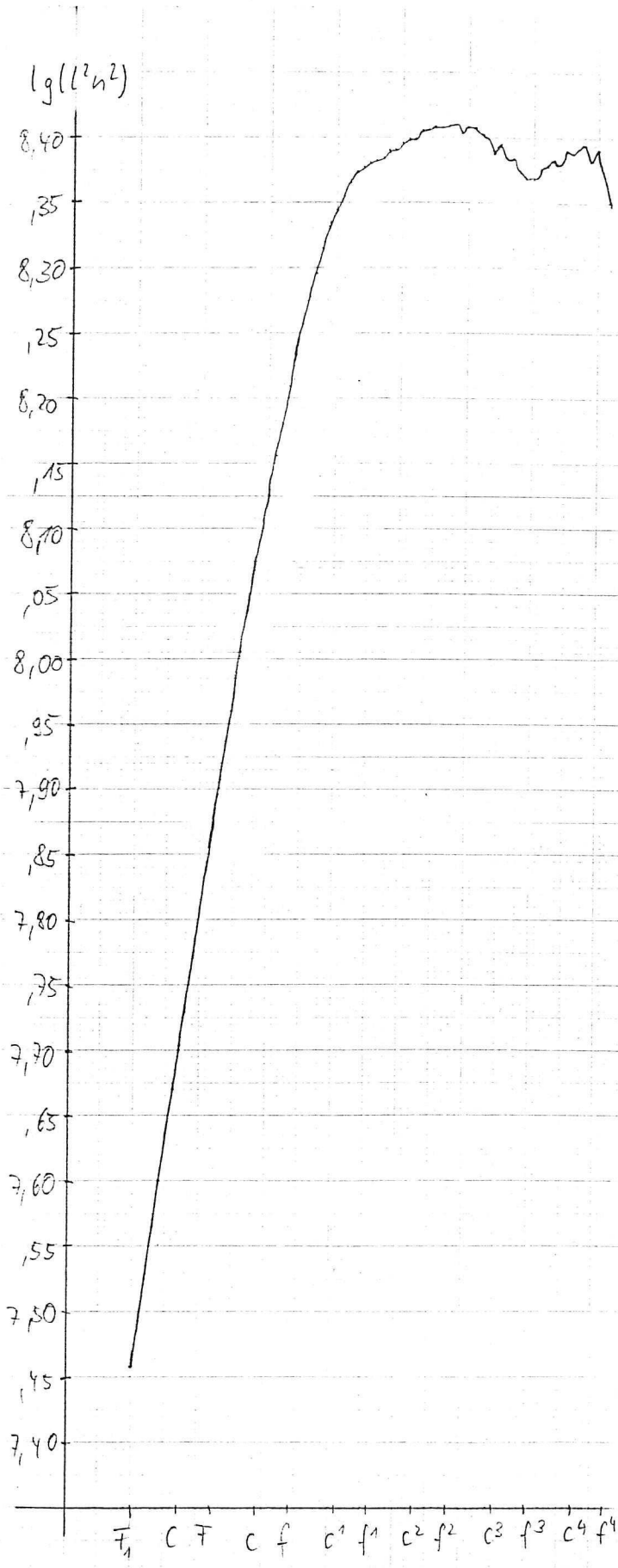

Reiseclavichord, Staats-
bibliothek, München

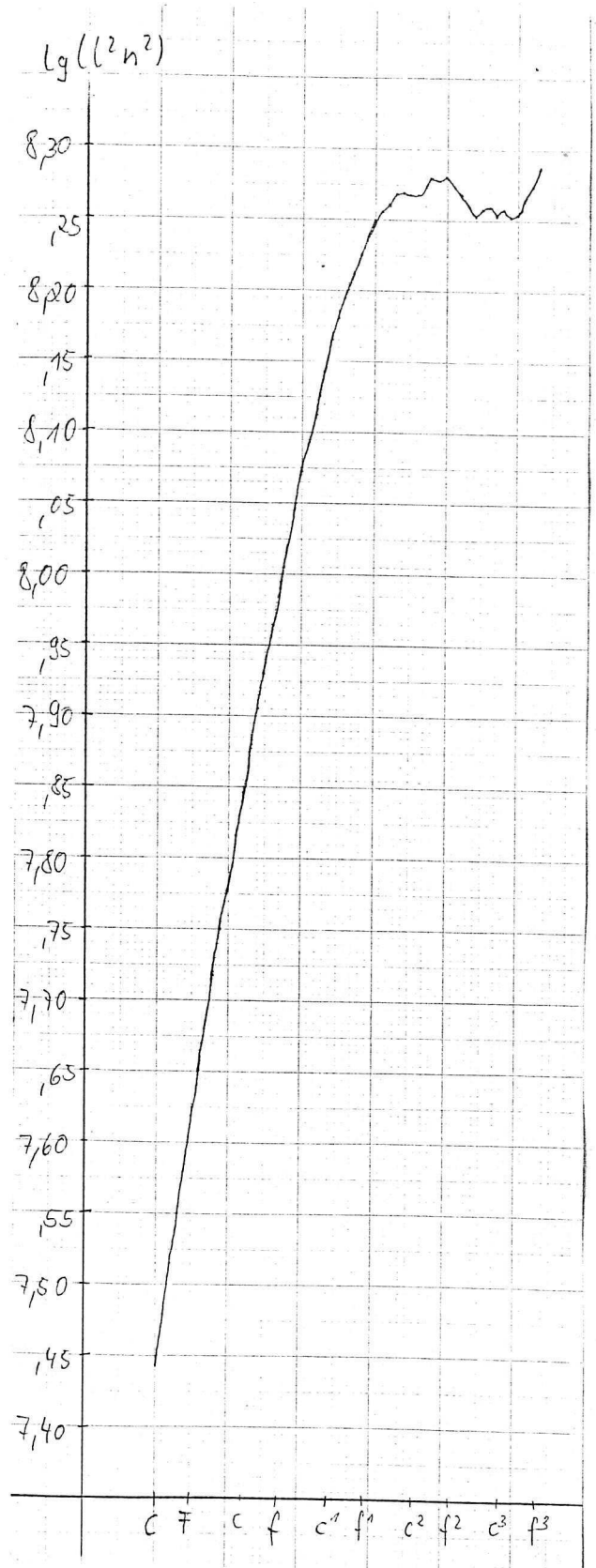

BAYERISCHES NATIONALMUSEUM, MÜNCHEN

Inv.Nr.28/1818

Inv.Nr.Mu 72 (Schmahl)

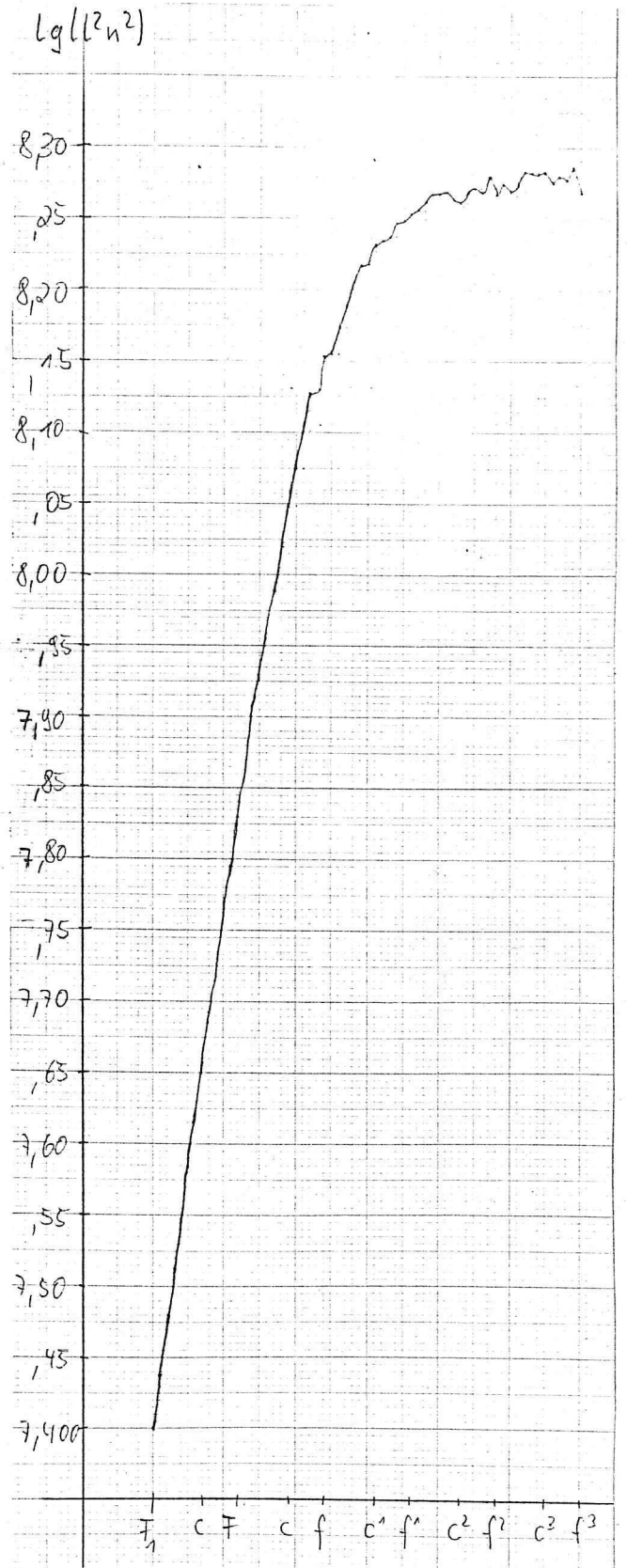
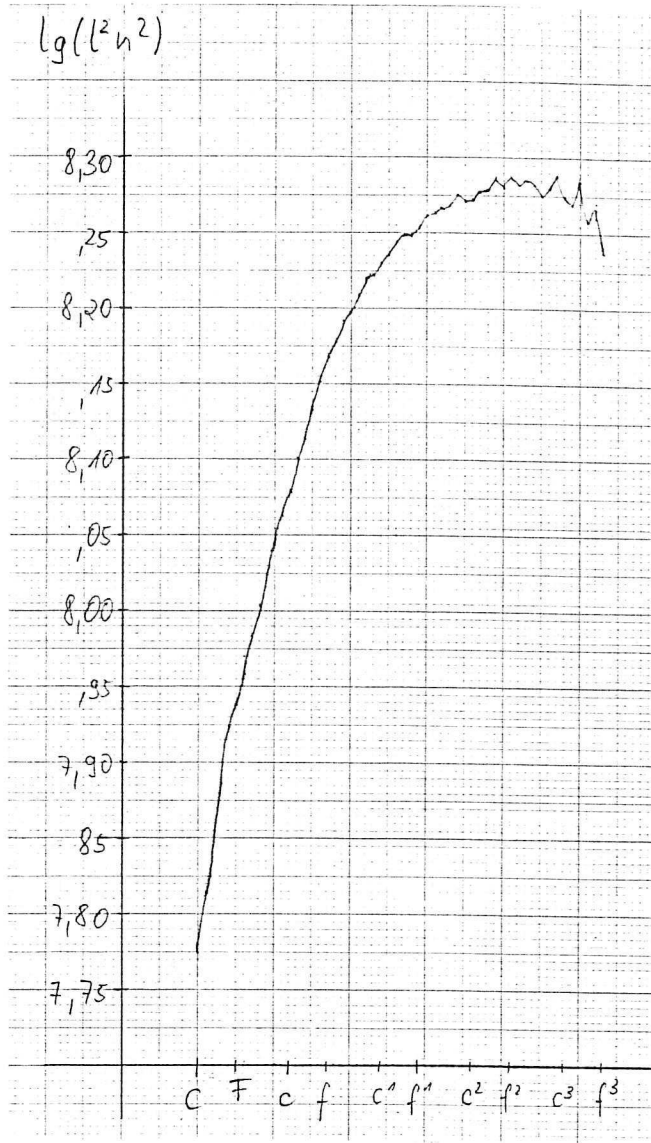

WÜRTTEMBERGISCHES LANDESMUSEUM STUTTGART

Inv.Nr. G 4111 (Schiedmayer)

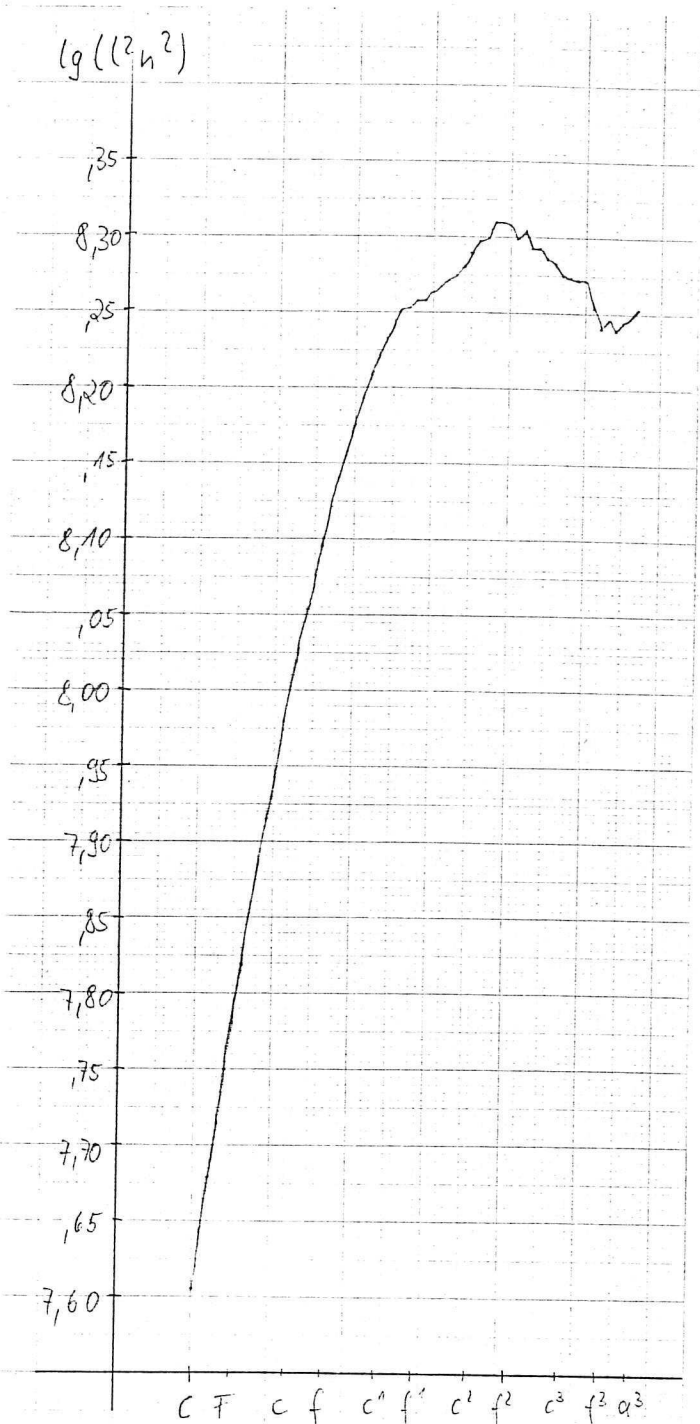

Stimmhammer:

Im Werkzeugkästchen des gebundenen Clavichords BNM 28/1818 befand sich ein Stimmhammer, von dem nachstehende Zeichnung angefertigt wurde. Er besteht aus zwei Teilen und erlaubt alle zum Aufzeihen und Stimmen der Saiten notwendigen Vorgänge.^{1.)}

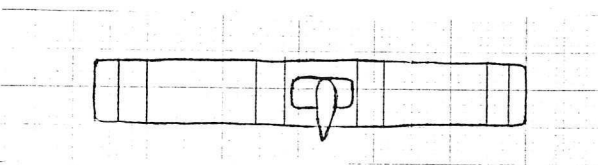
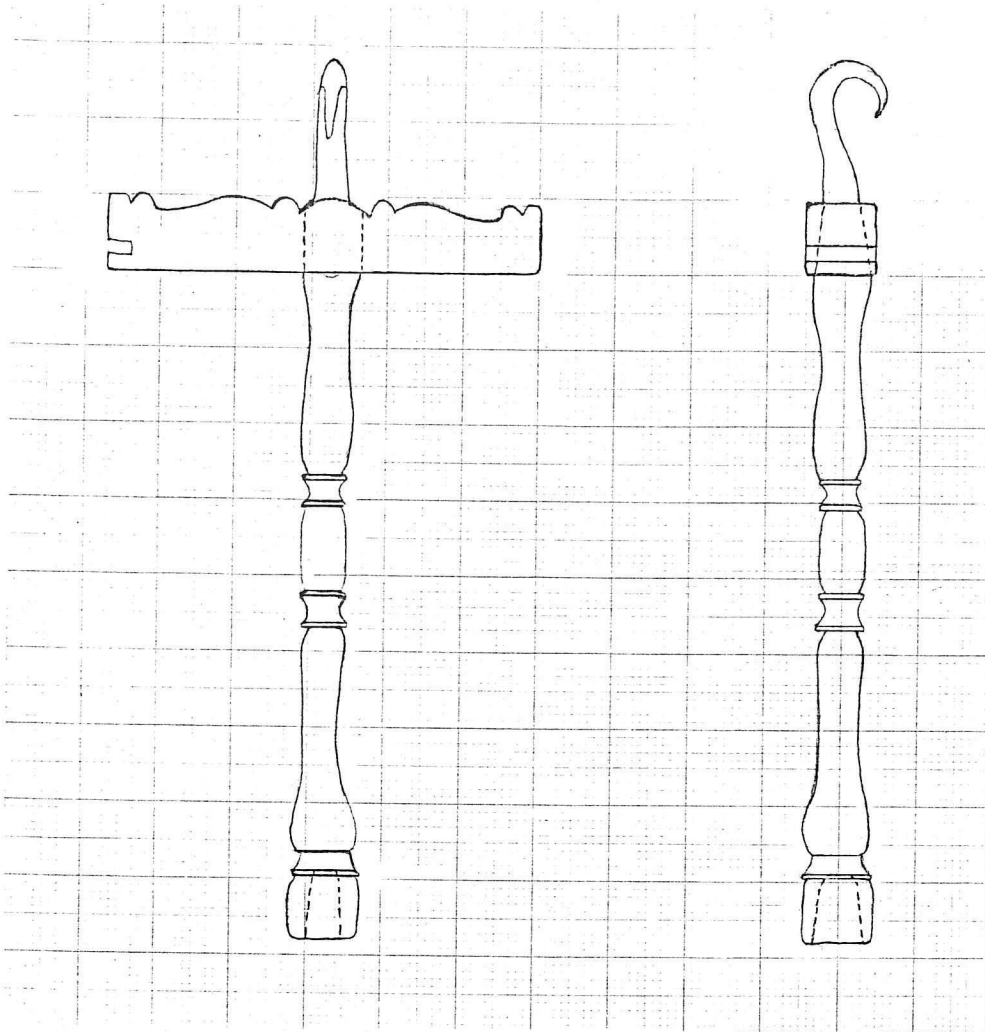

1:1

* * *

1.) Vgl. Kap. "Bautechniken", S. 45.

IV. FOTOGRAFIEN



Abb.1: DM 18165 (2.Hälfte 17. Jh.)

Foto: DM

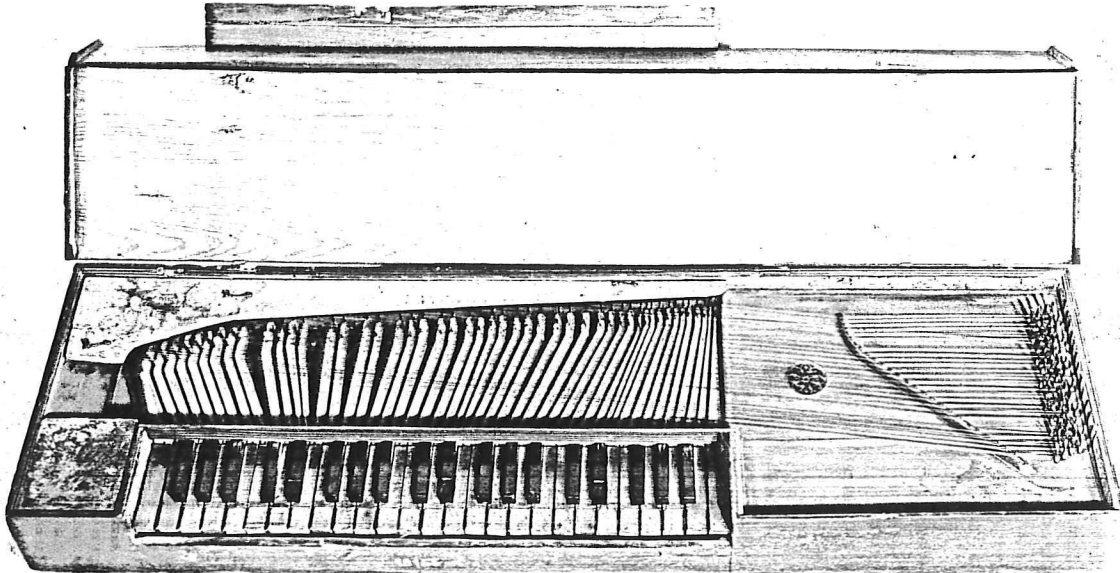

Abb.2: oben: DM 18165; unten: DM 5392 (Weiss, 1702)

Foto: DM



Abb.3: DM 5392 (Weiss, 1702). Mit originalem Resonanzboden.

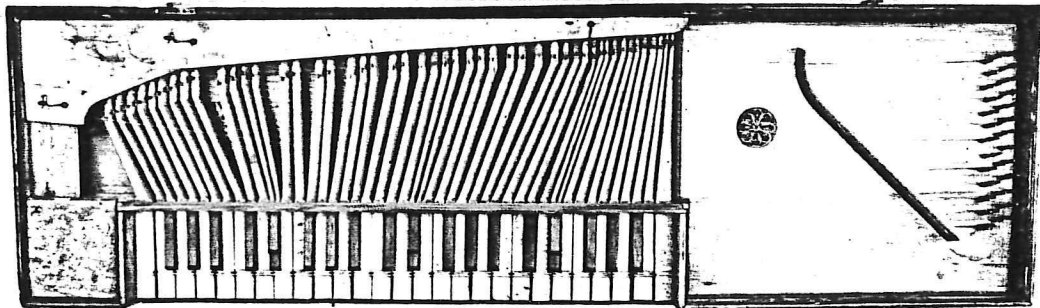

Abb.4: Signatur von DM 5392.

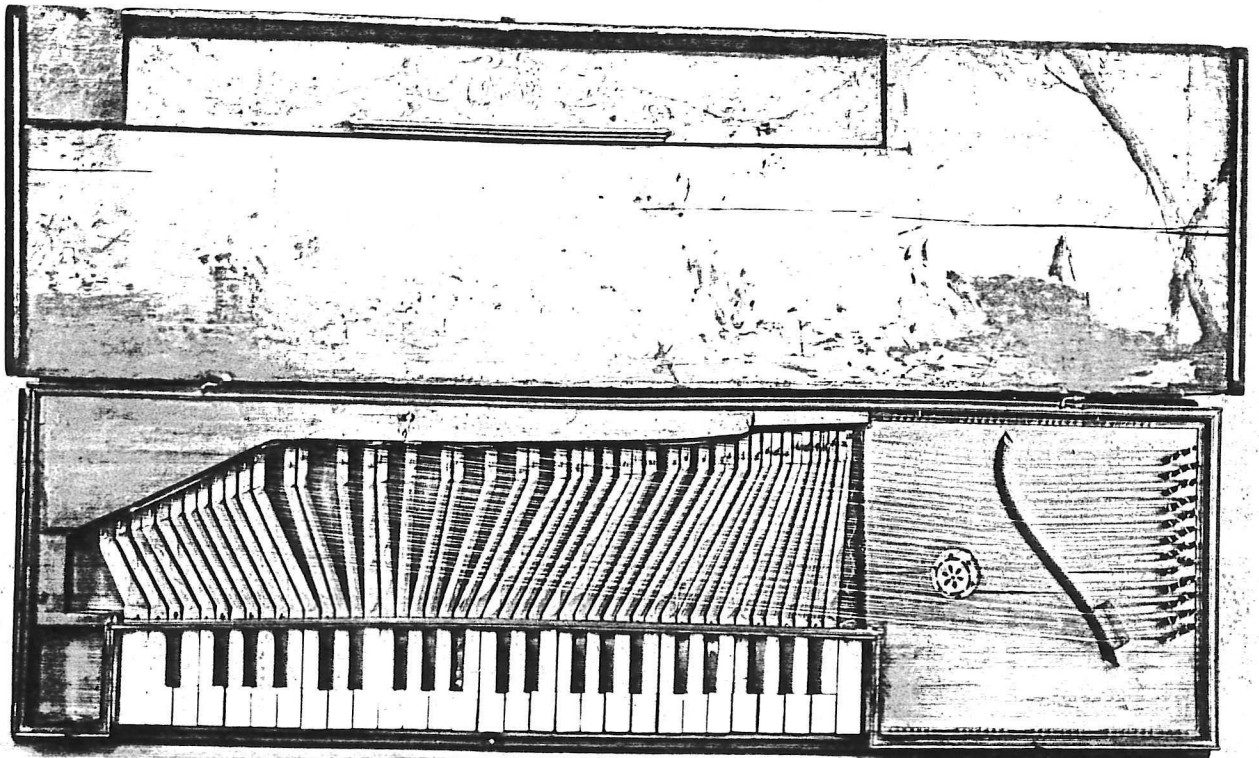

Abb.5: DM 16816 (König, 1739)

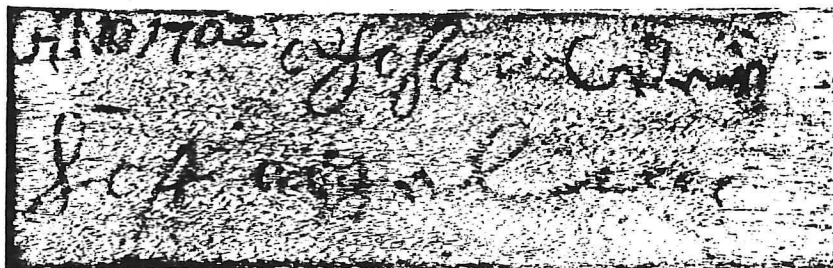

Abb.6: Signatur von DM 16816.

Foto: DM

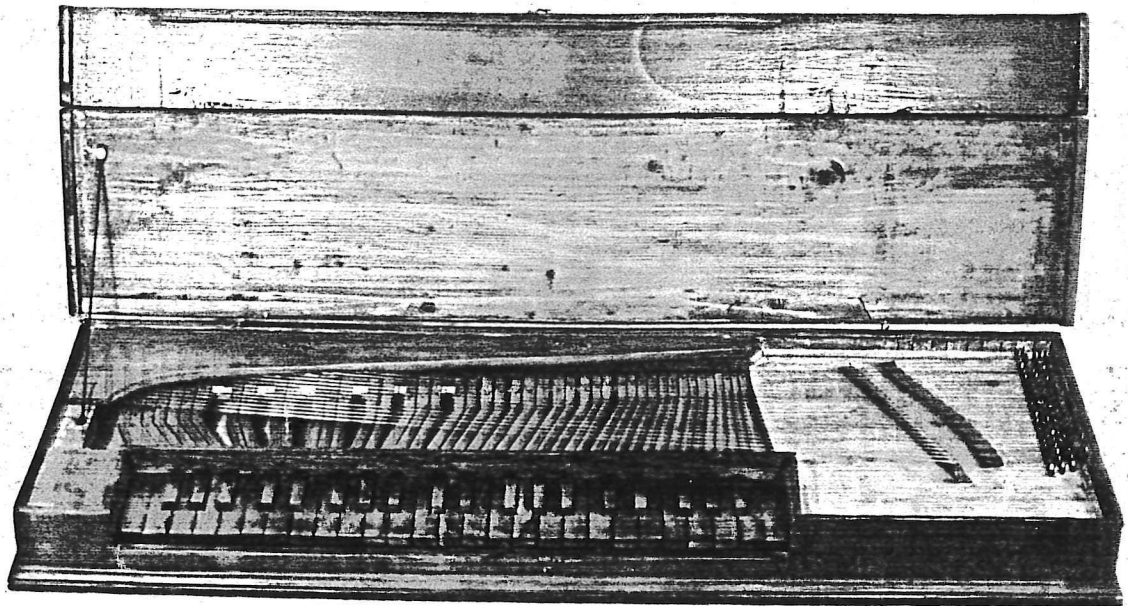

Abb.7: DM 20780 (Lemme, 1766)



Abb.8: DM 20780

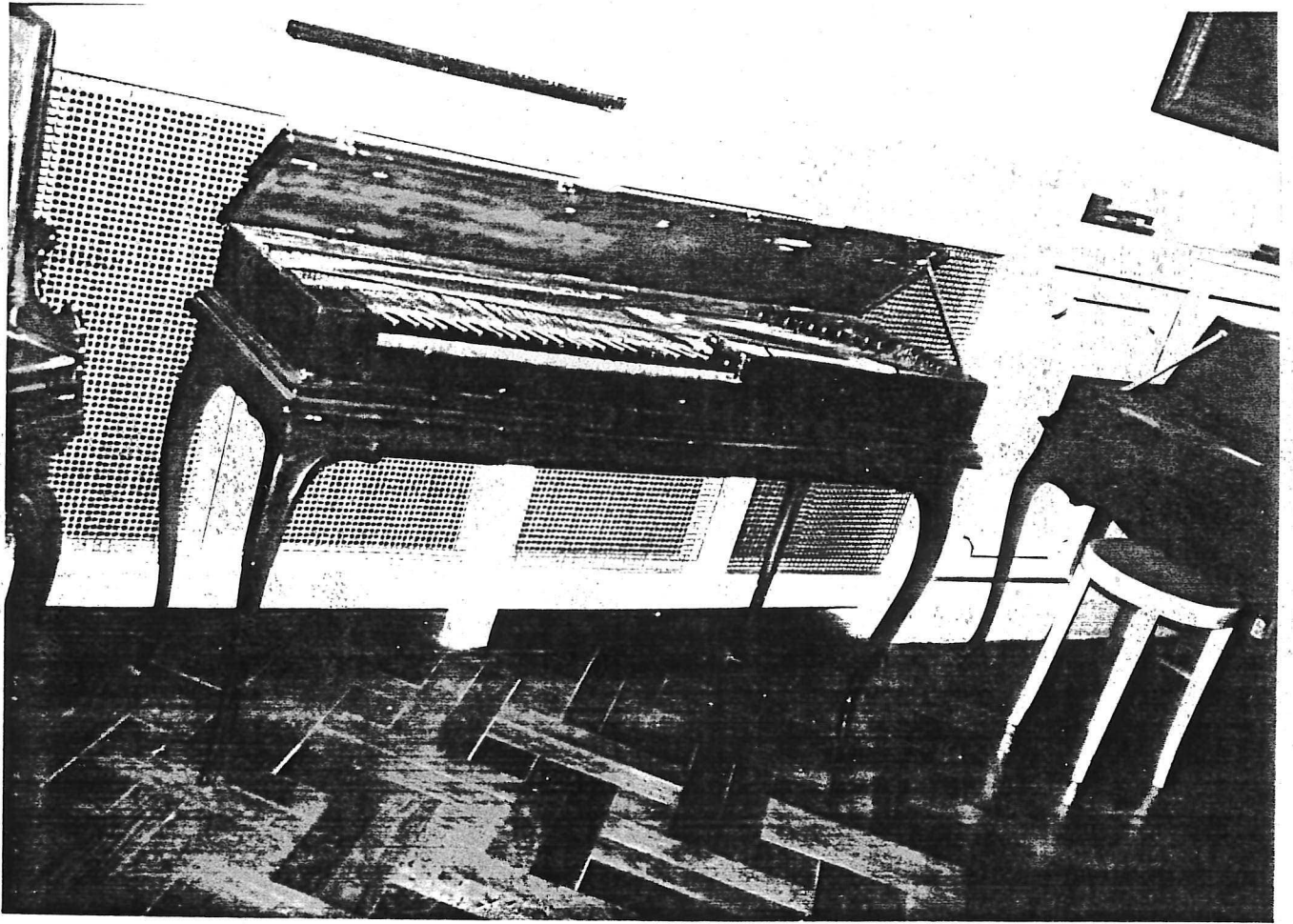

Abb.9: Signatur von DM 20780.

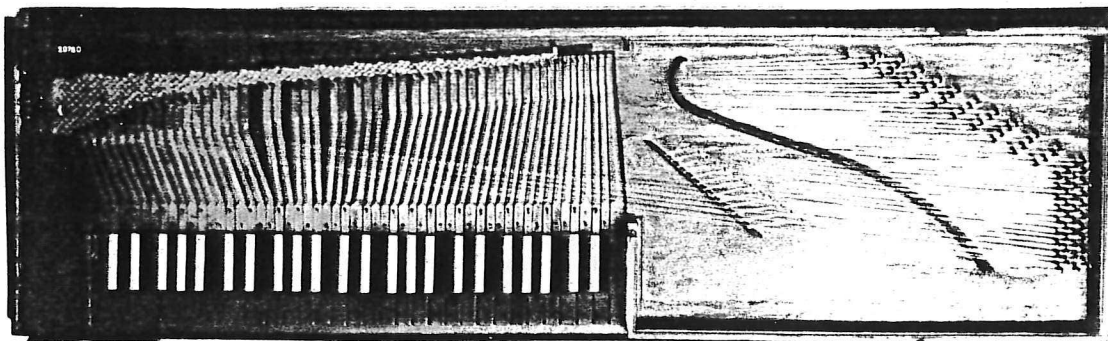

Abb.10: DM 5385 (Hubert, 1782)

Foto: DM



Abb.11: DM 5385.

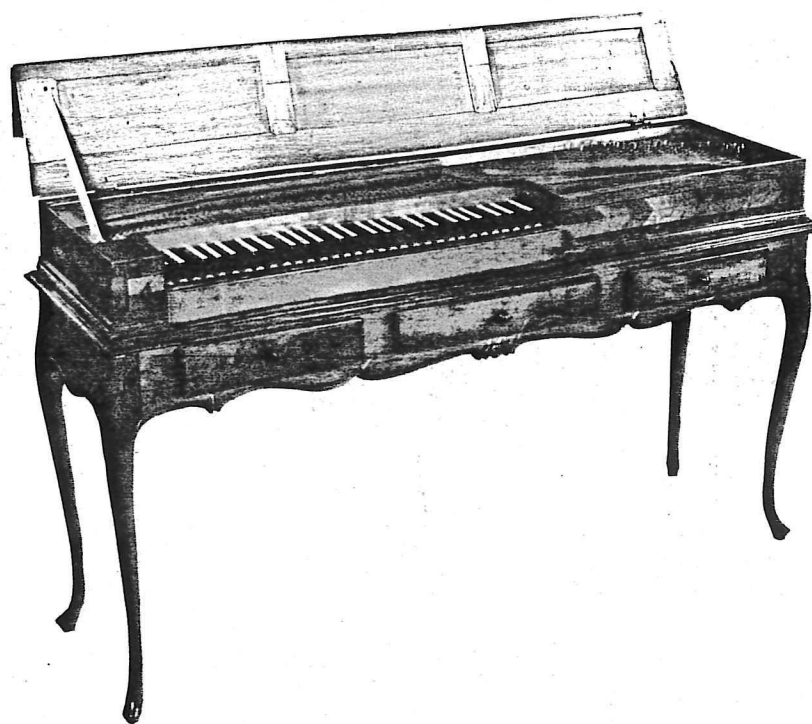

Abb.13: DM 46116 (Schmah1?)

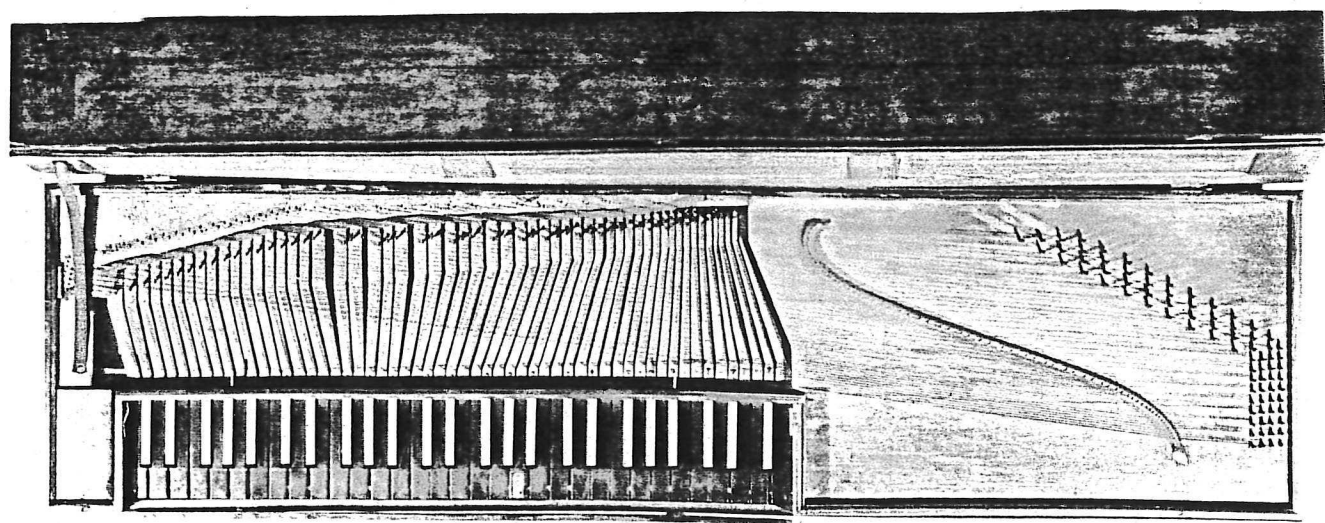

Foto: DM

Abb.12: Signatur von 5385 (Hubert)

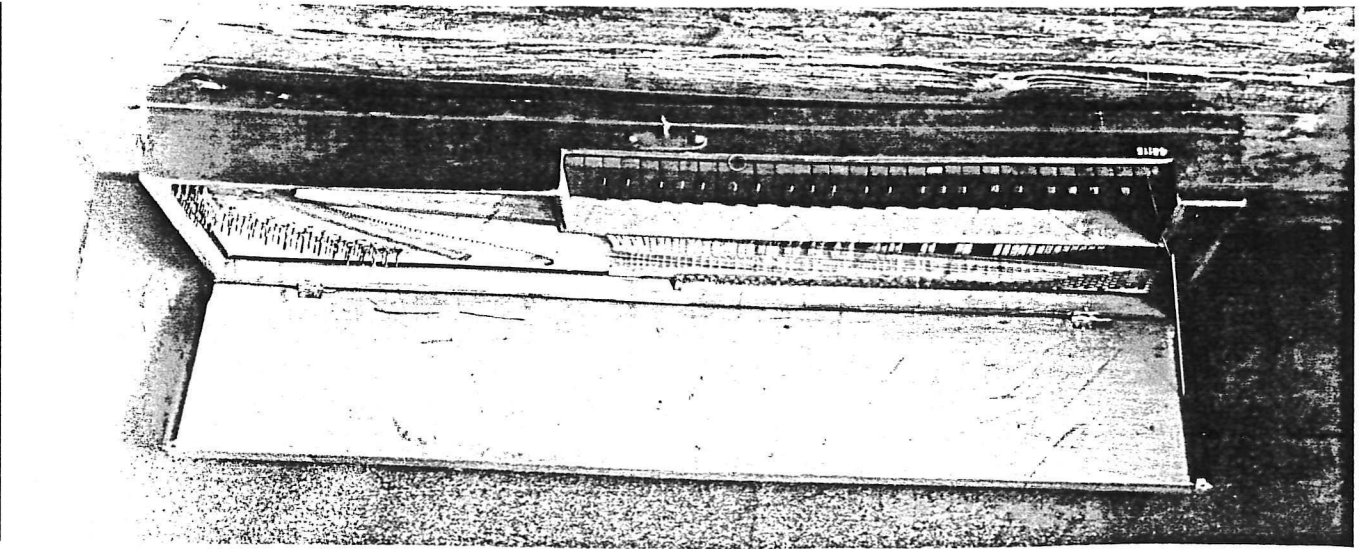

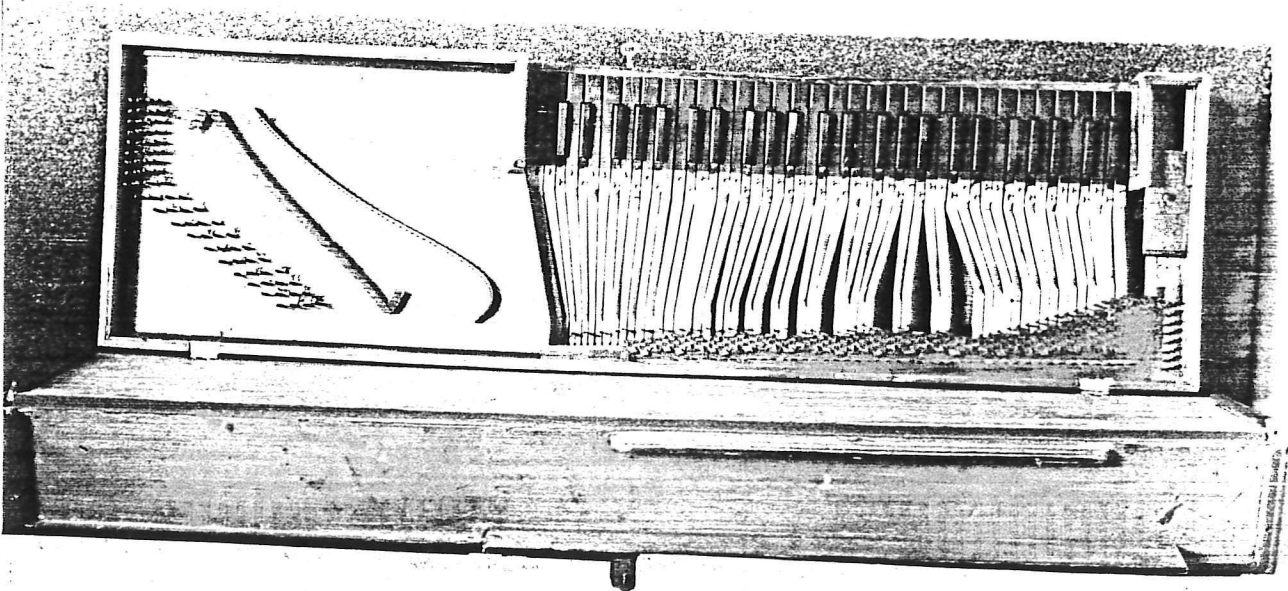

Abb. 15: DM 5393 (Horn, 1796)

Foto: DM



Abb.16: DM 5393 (Horn)

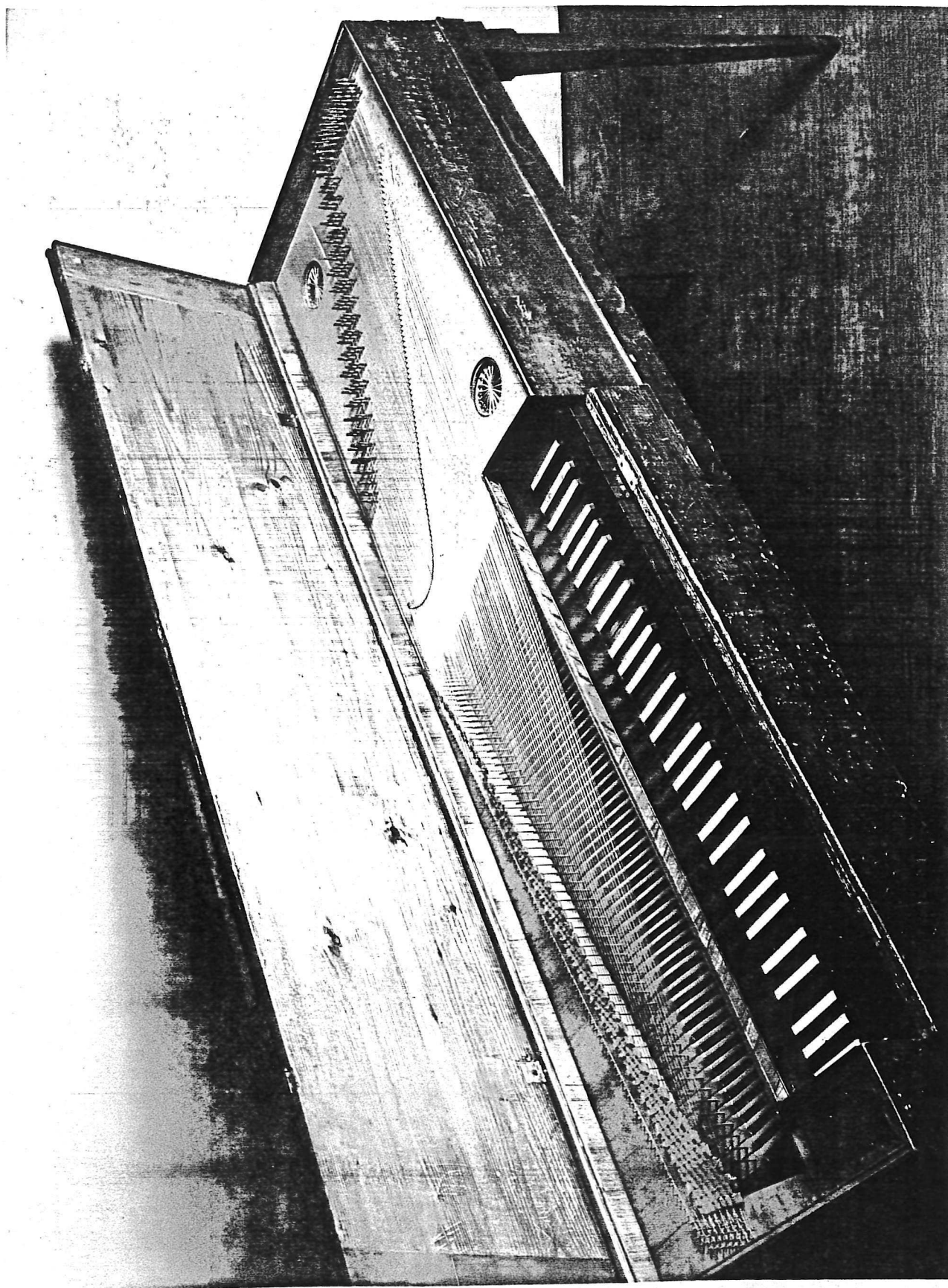

Abb.17: Signatur von DM 5393.

(Die Fotografien des Clavichords DM 17214, Gebr. Schmahl 1812/15, befinden sich auf Bl. LXXIII.)

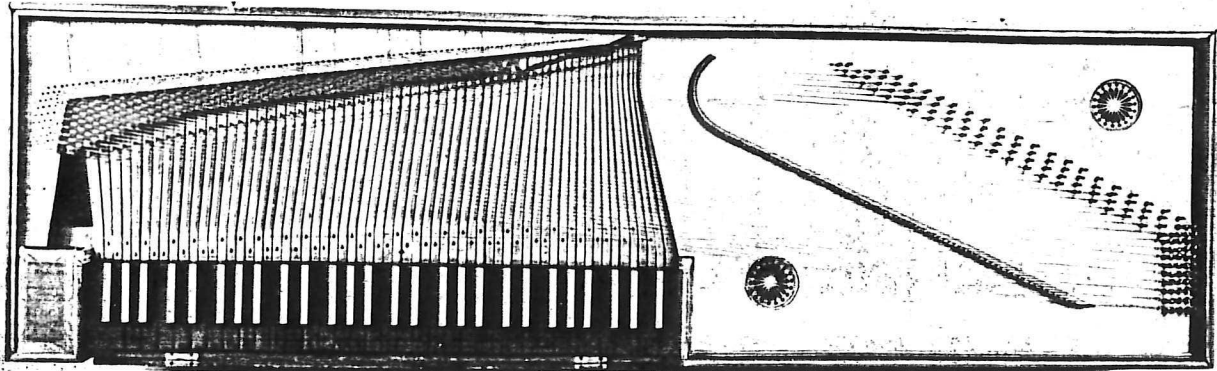

Abb.18.: DM 34072 (Glück?, 19.Jh). Die Pedalklavatur ist nicht original.

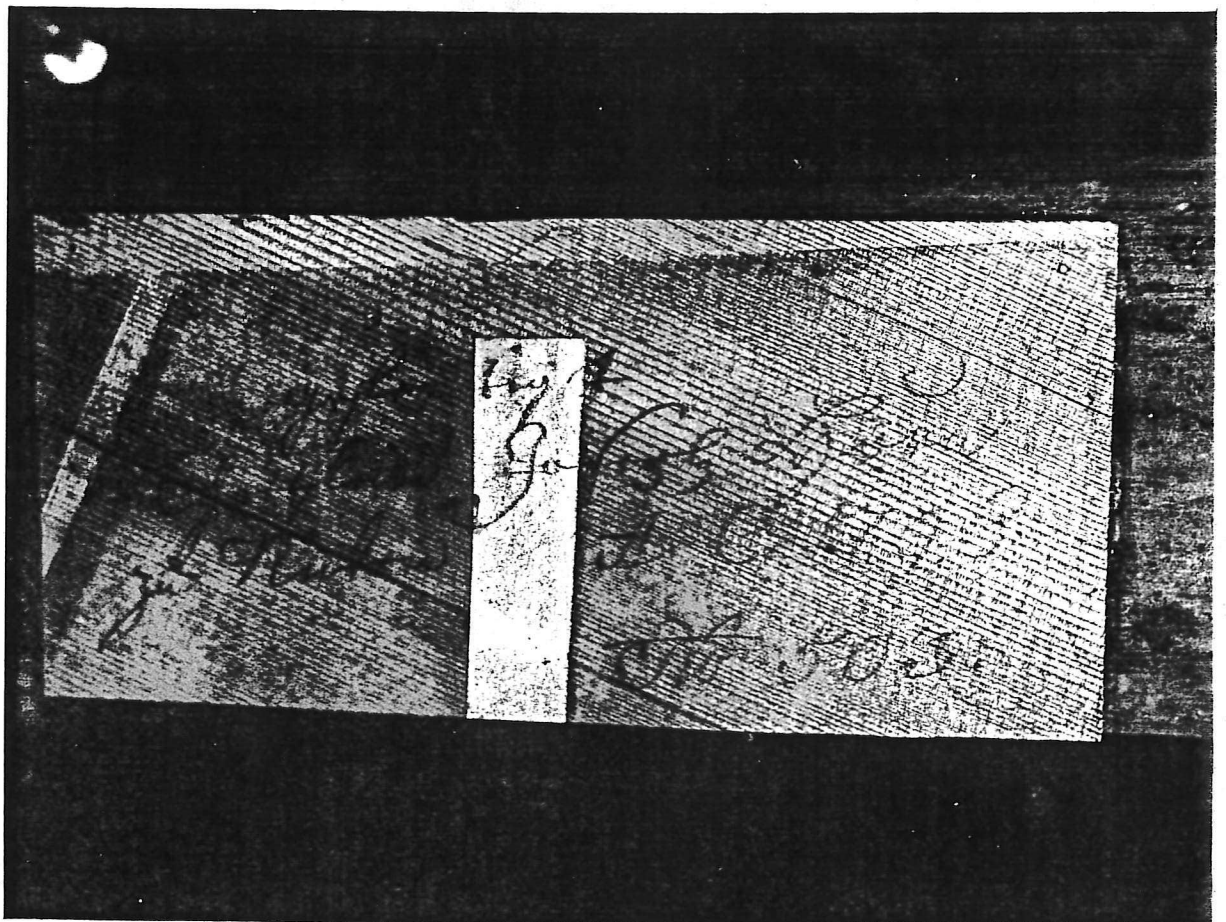
Foto: DM



Abb.19: DM 34072, Manualclavichord.

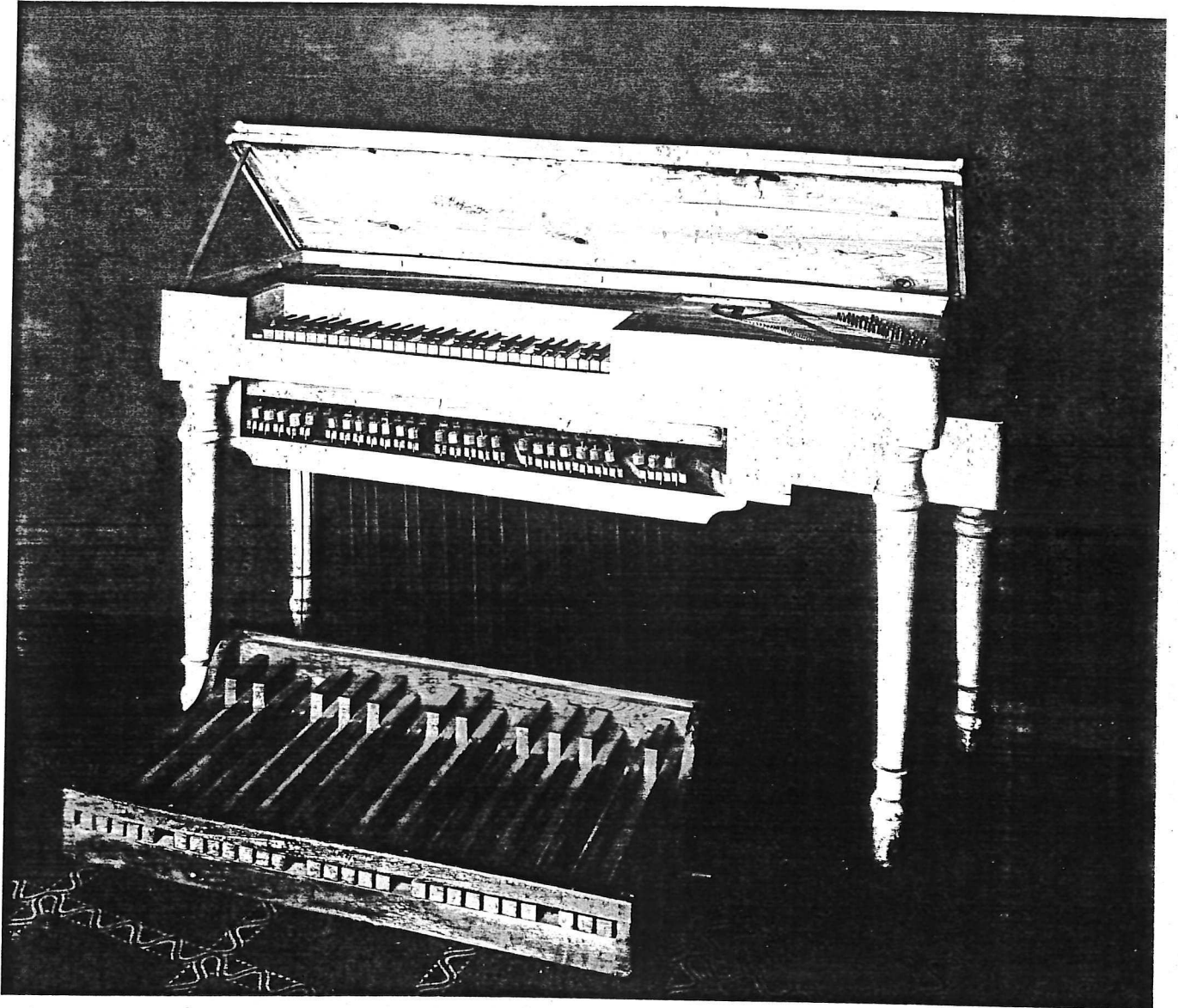

Abb.20: DM 34072, Pedalclavichord.

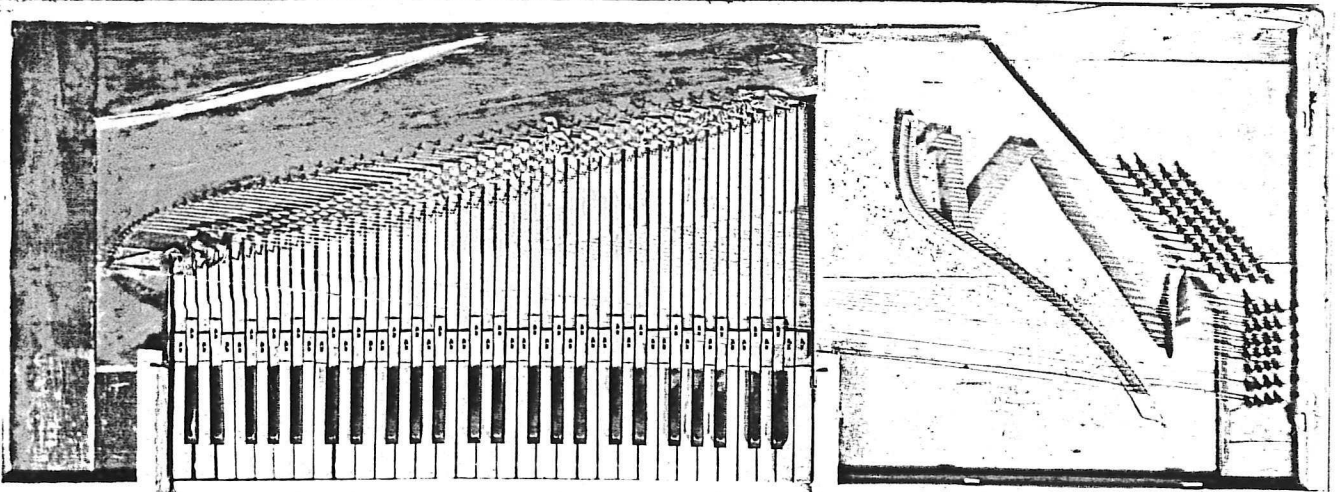

Abb.21: DM 34072.
In ihren Rahmen
eingelegte Tangen-
tenhebel.

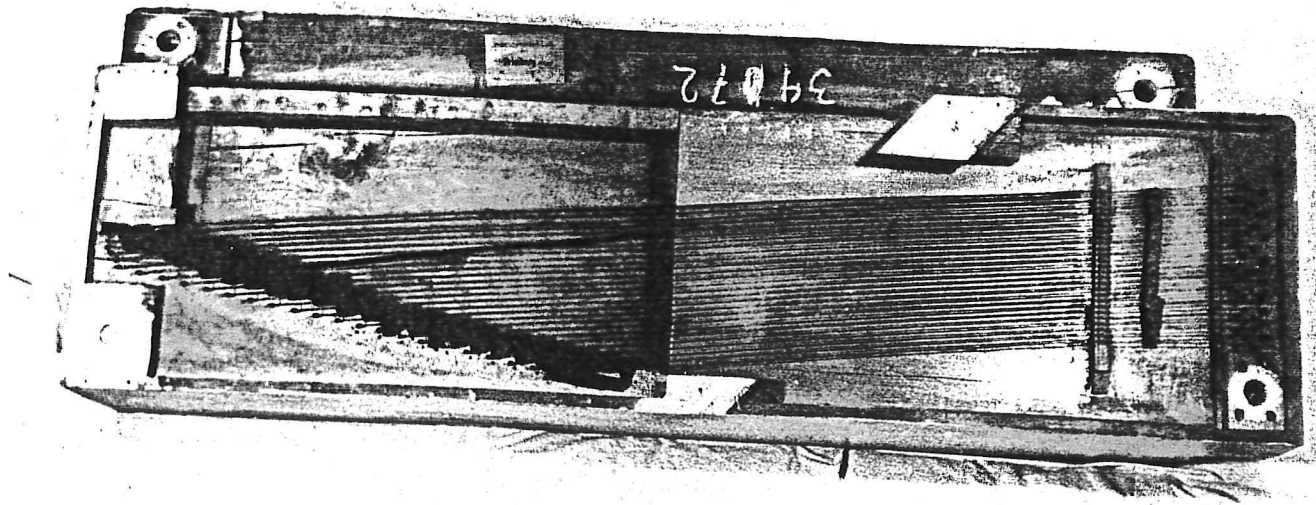

Abb.22: DM 34072.
Heutiger Zustand
des Instruments.

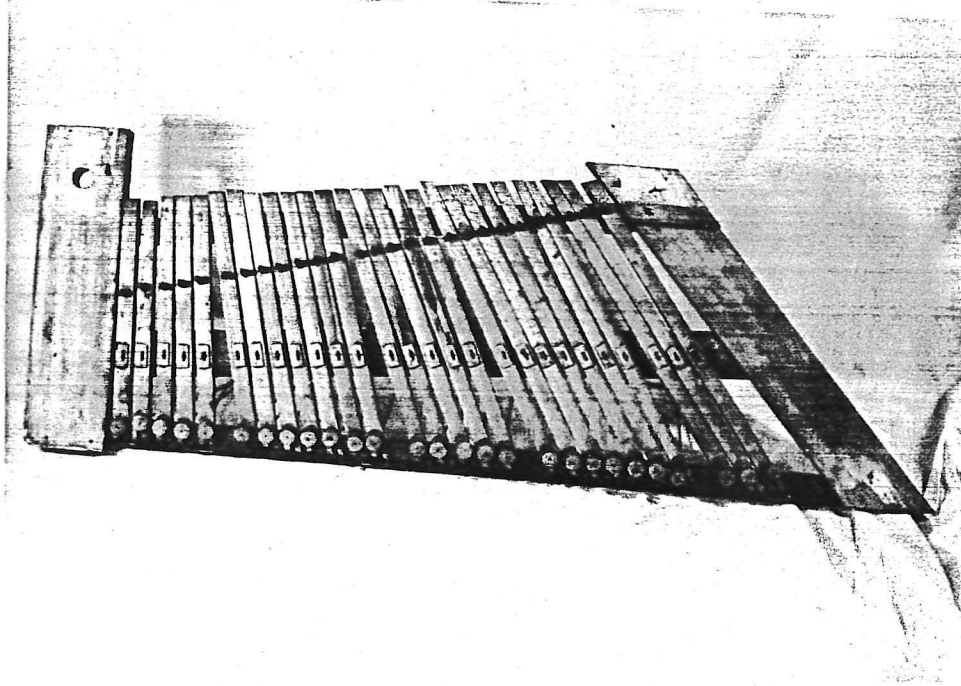

Abb.23: MS 70-103 (um 1700)

Foto: MS

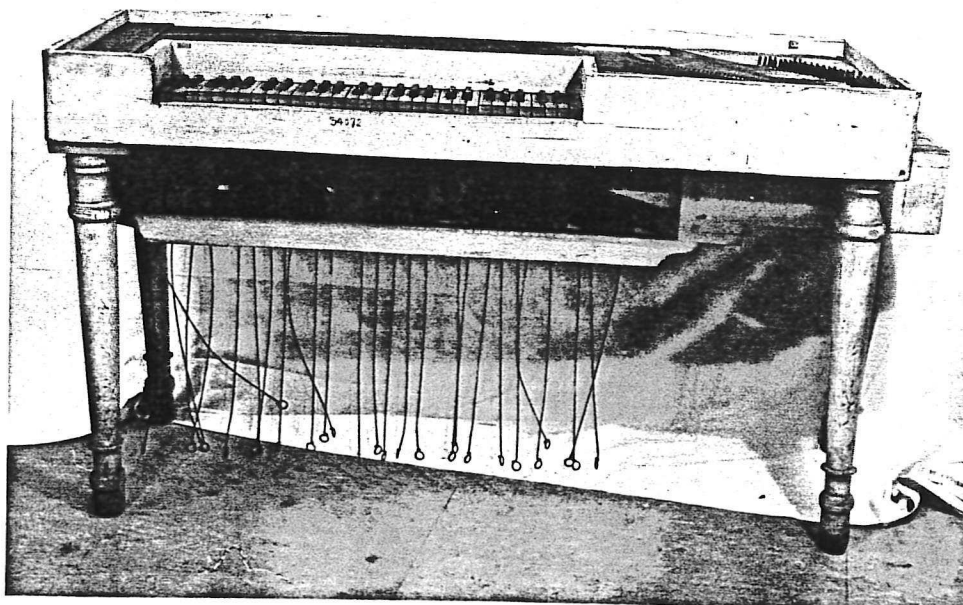

Abb.24: MS 82-2, Clavichord mit "Lautenzug" (Mitte 18. Jh.).

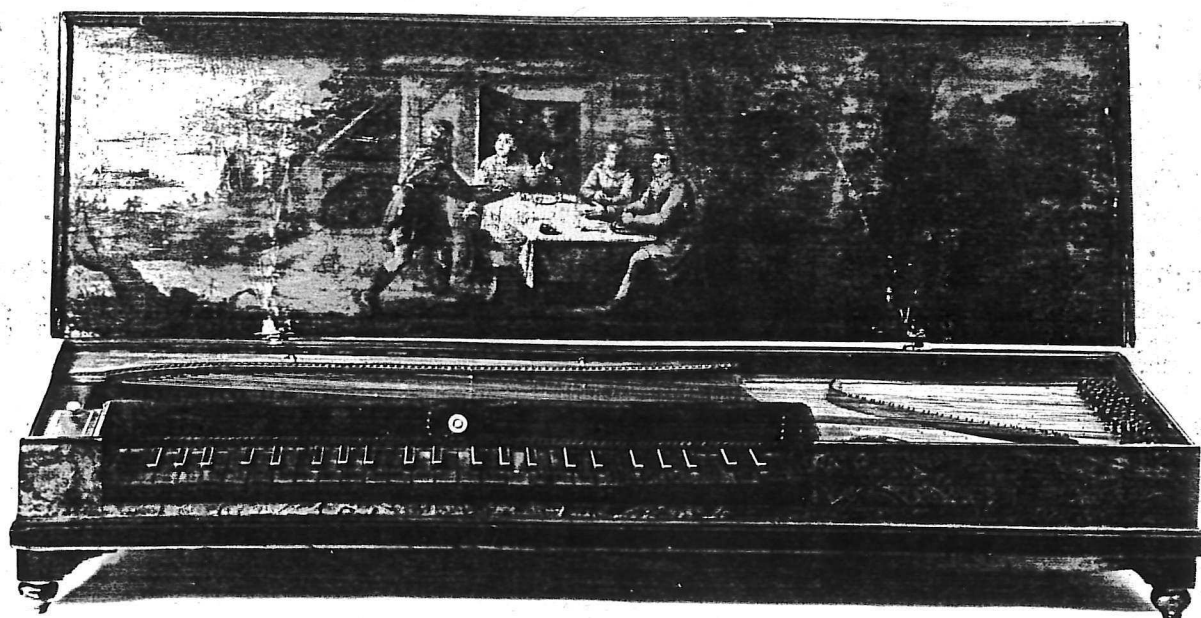

Abb.25: MS 82-2 (Mitte 18. Jh.)

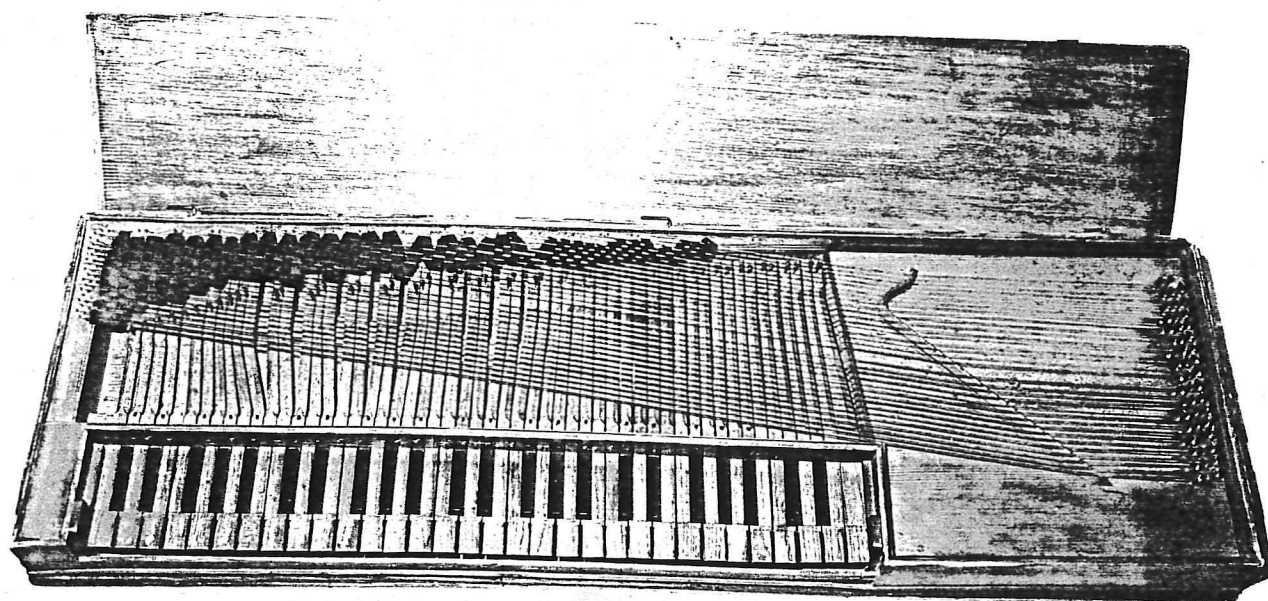

Abb.26: MS 82-2, belederte Tangente.

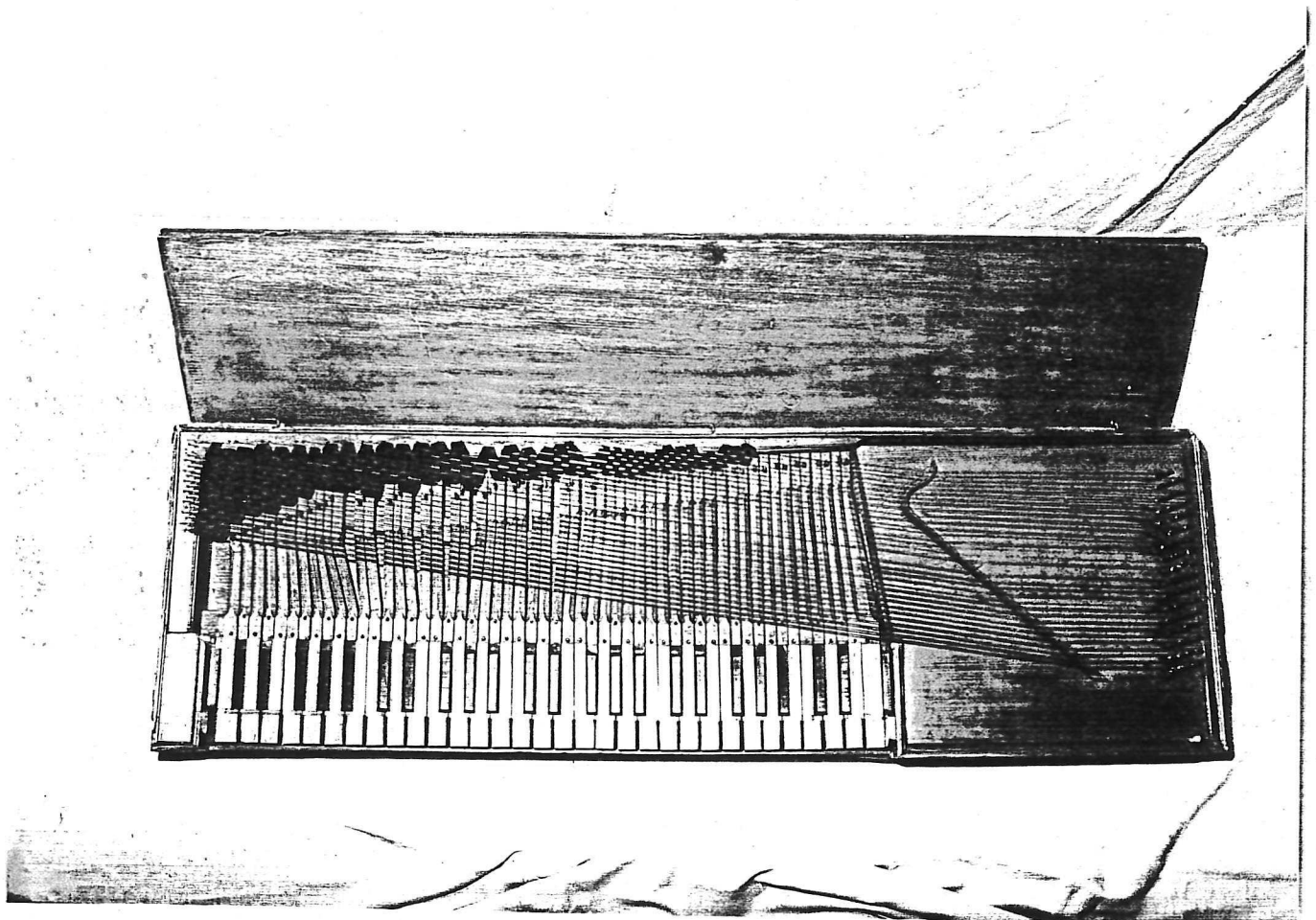

Abb.27: MS 69-15 (2.Hälfte 18.Jh)

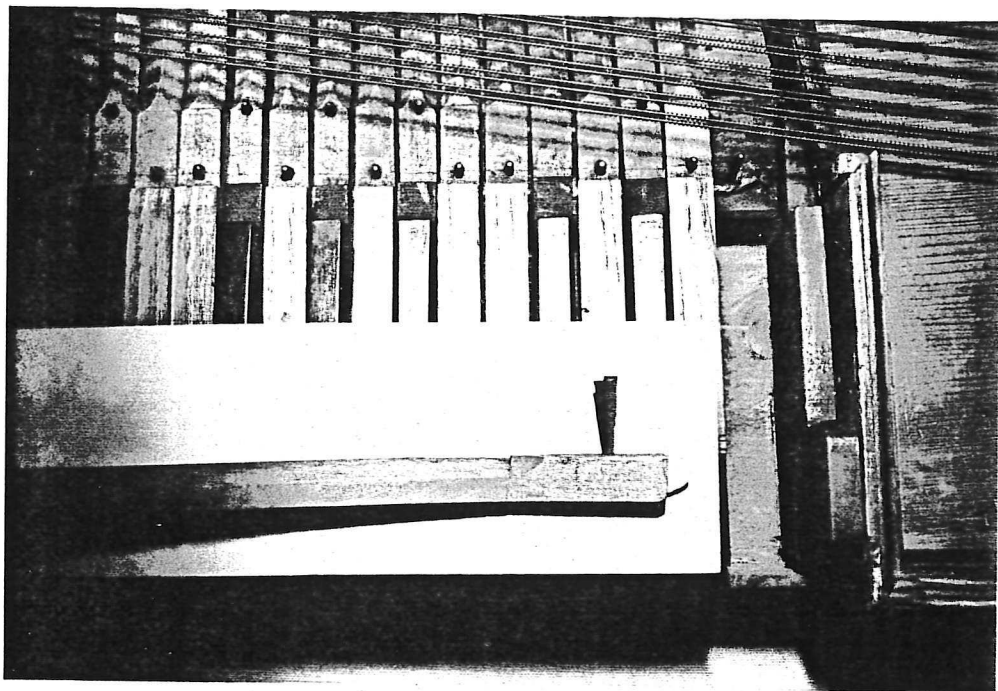

Abb.28: MS 69-15

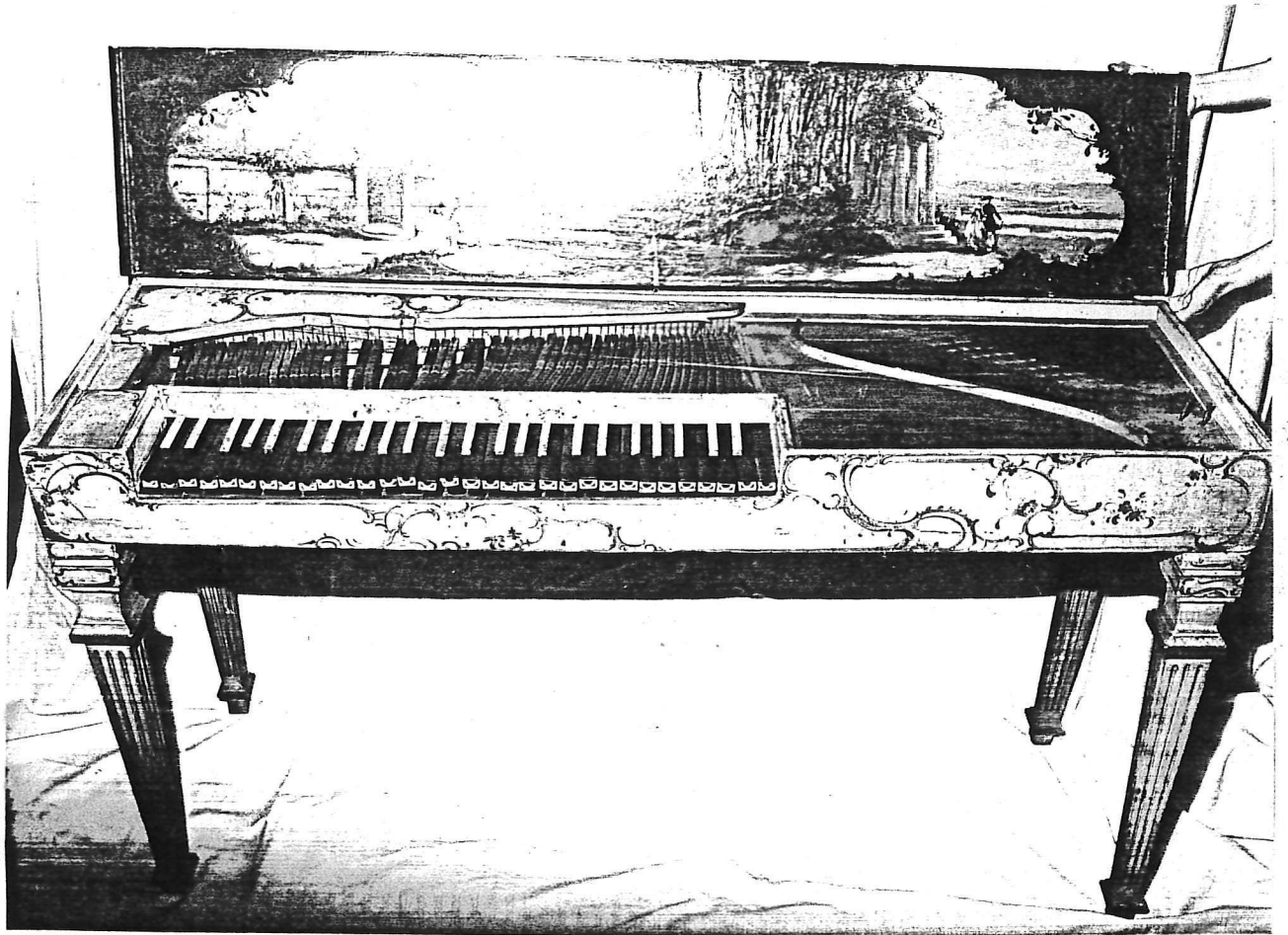

Abb.29: MS 44-1 (2.Hälfte 18.Jh.)

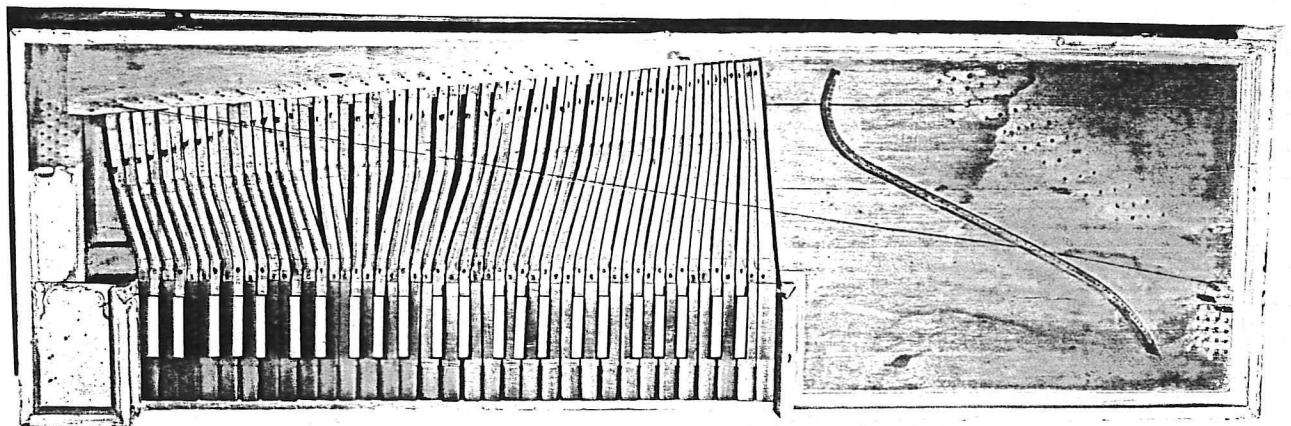

Abb.30: MS 44-1

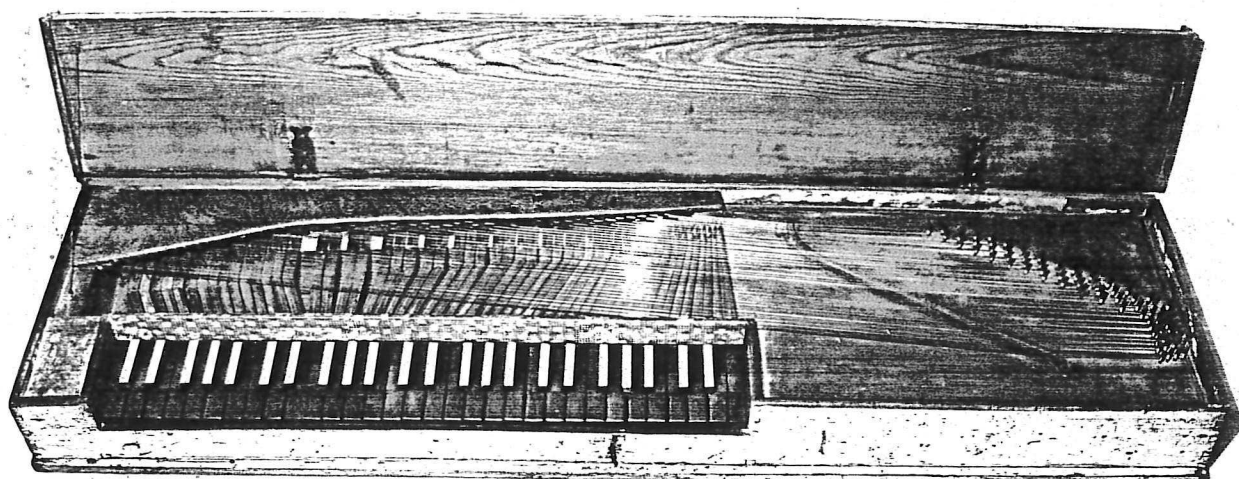

Abb.31: MS 44-2 (Horn?)

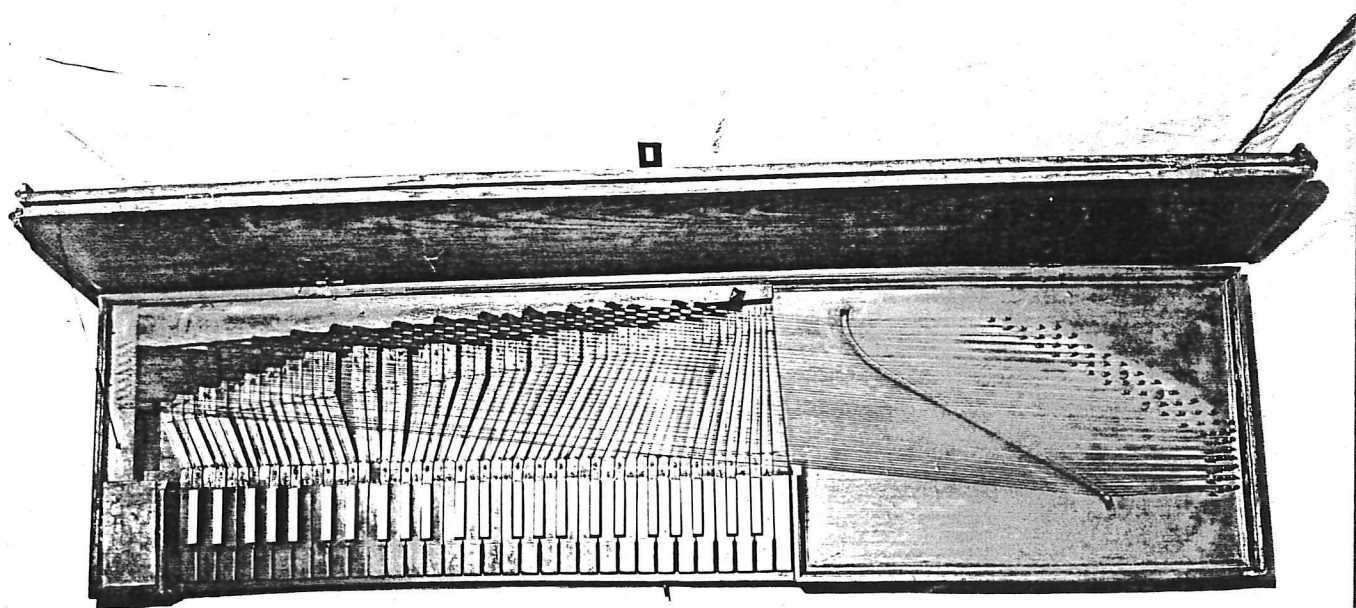

Abb.32: MS 44-2

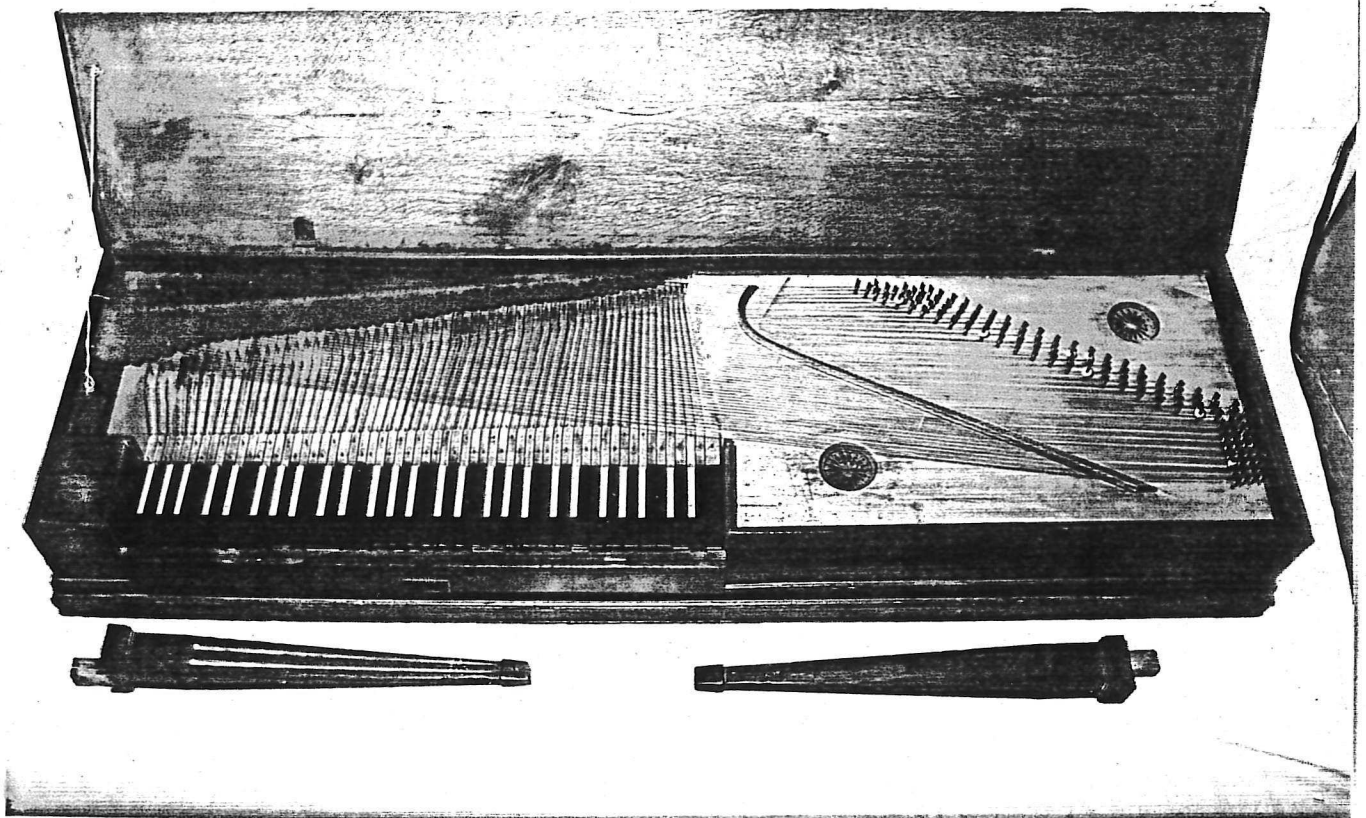

Abb.33: MS 44-3 (letztes Drittel 18.Jh)

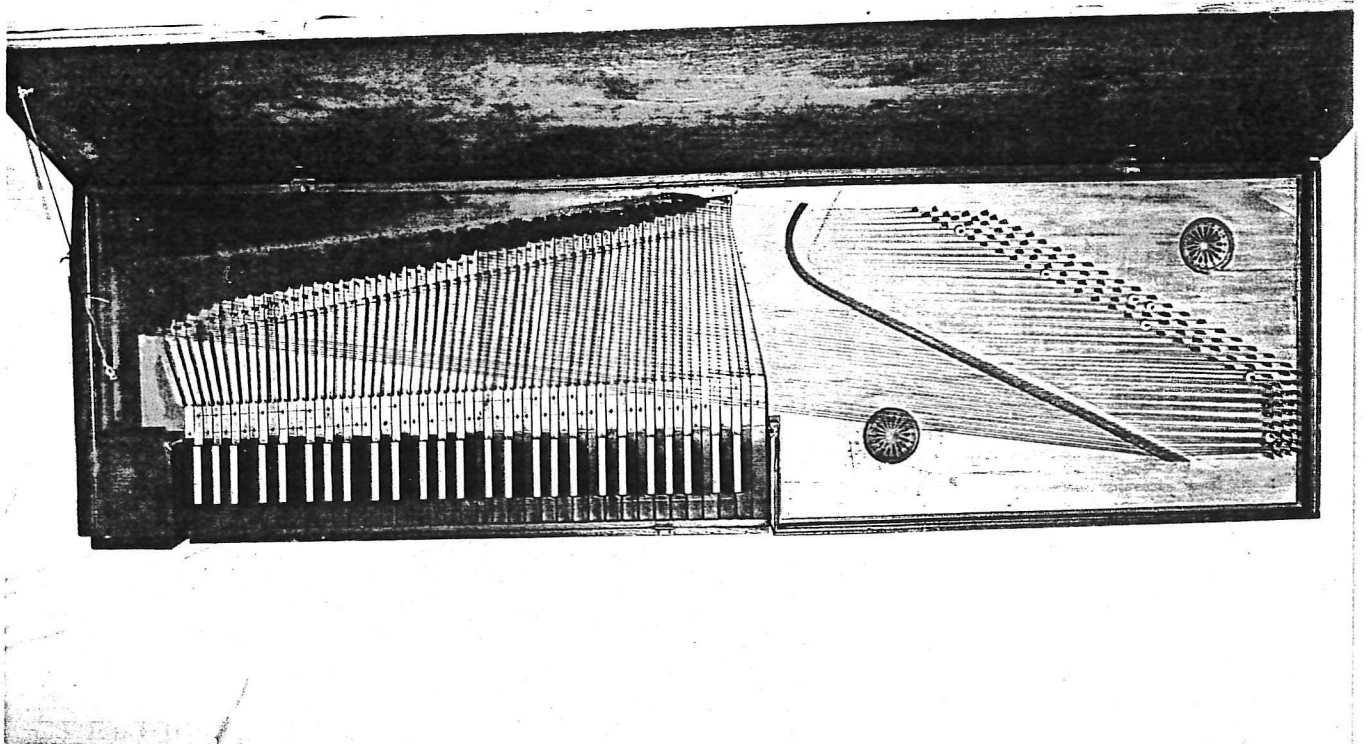

Abb.34: MS 44-3

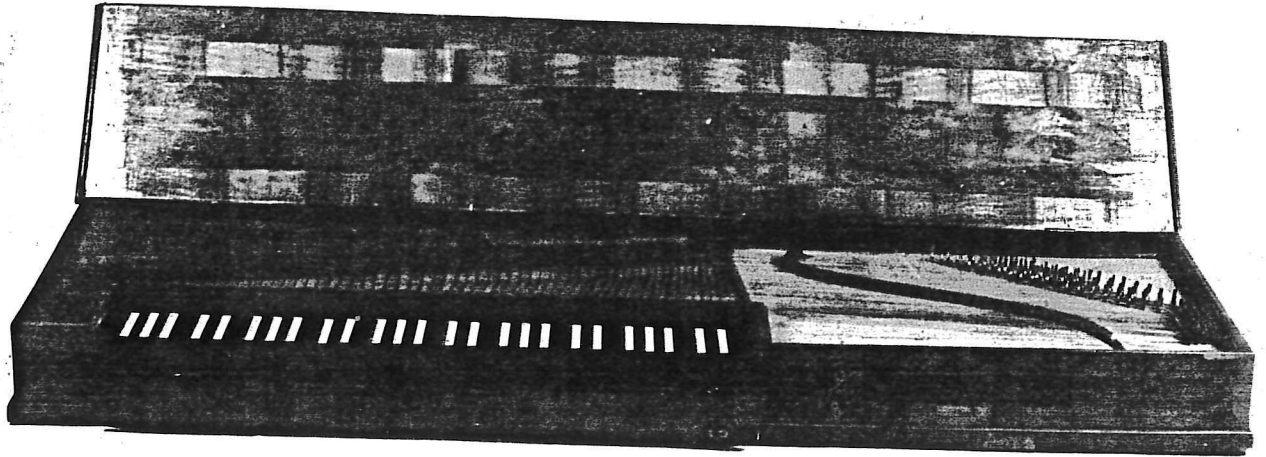

Abb.35: MS 44-3
Stirnflächen-
verzierungen.

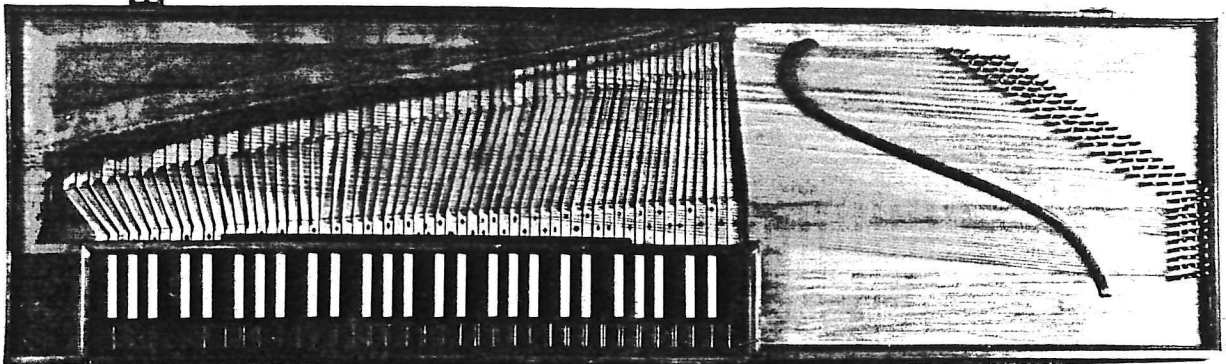

Abb.36: MS 44-4 (deutsch oder schwedisch 1810-1820)

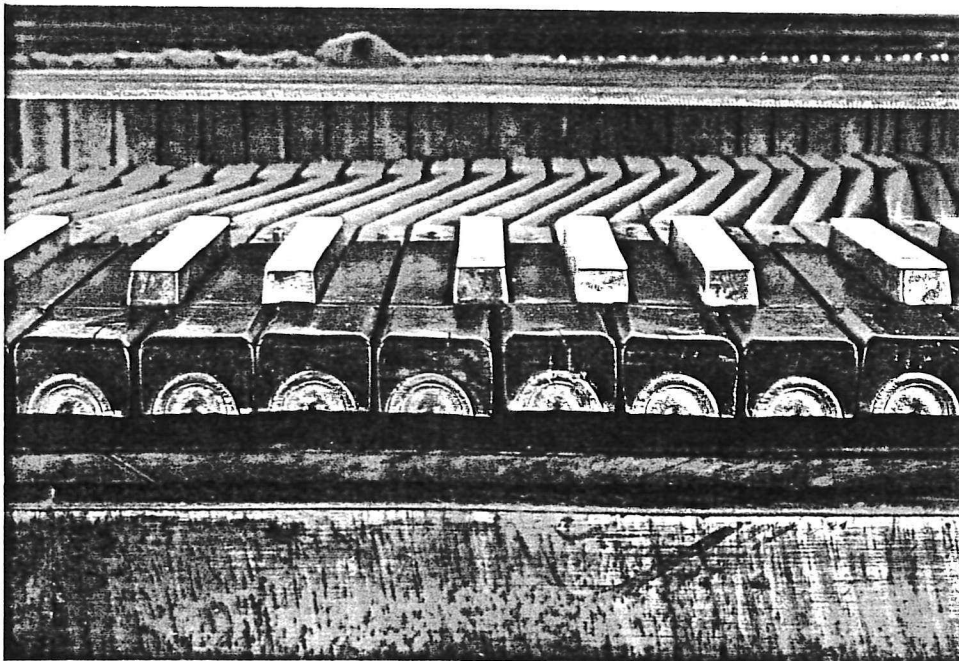

Abb.37: MS 44-4

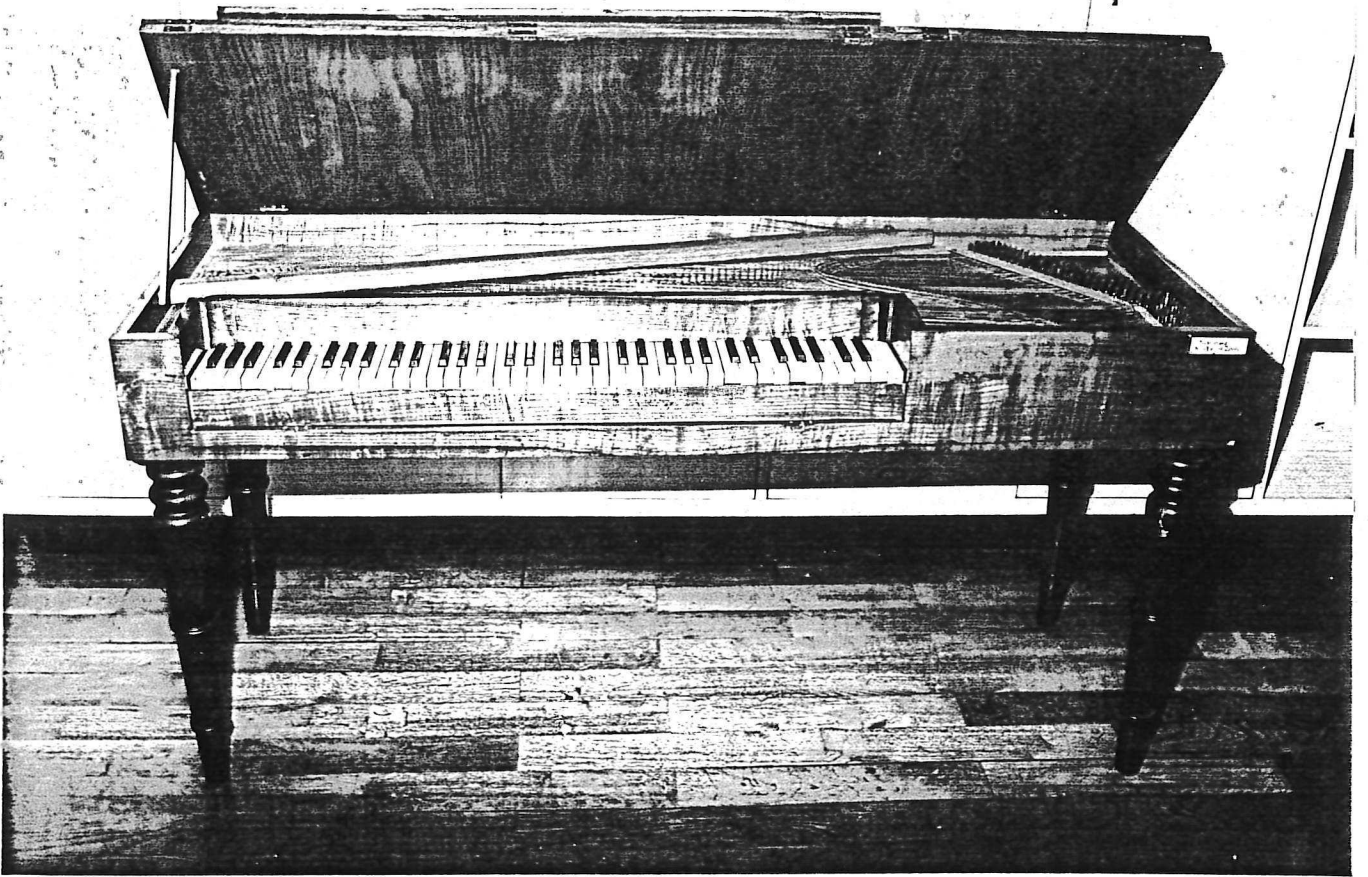

Abb.38.: MS 44-4, herausgenommener Klaviaturrahmen und -schlitten.

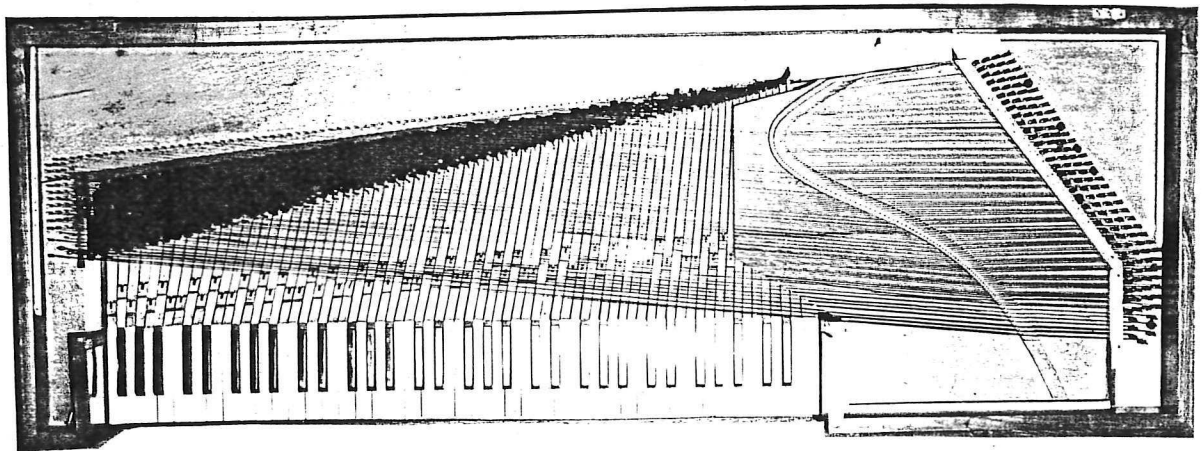

Abb.39: aus: Helenius-Öberg, E.: Svenskt Klavikordbygge 1720-1820, Uppsala 1986, S.55.

Fig. 42. The master's test drawing presented to the Stockholm Guild of Carpenters by Anders Nordström on October 9th, 1812. The drawing shows an early pianoforte of a normal type. Photograph from a microfilm of the original in the Stockholm Association of Master-Joiners.

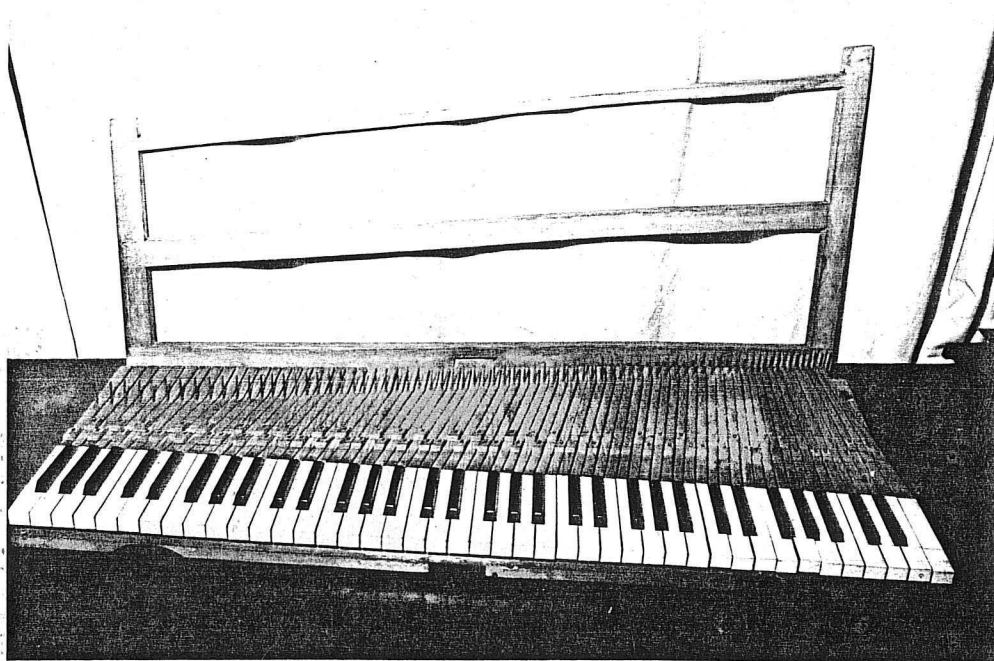

Abb.40: BNM 28/1818 (2.Hälfte 18. Jh.)

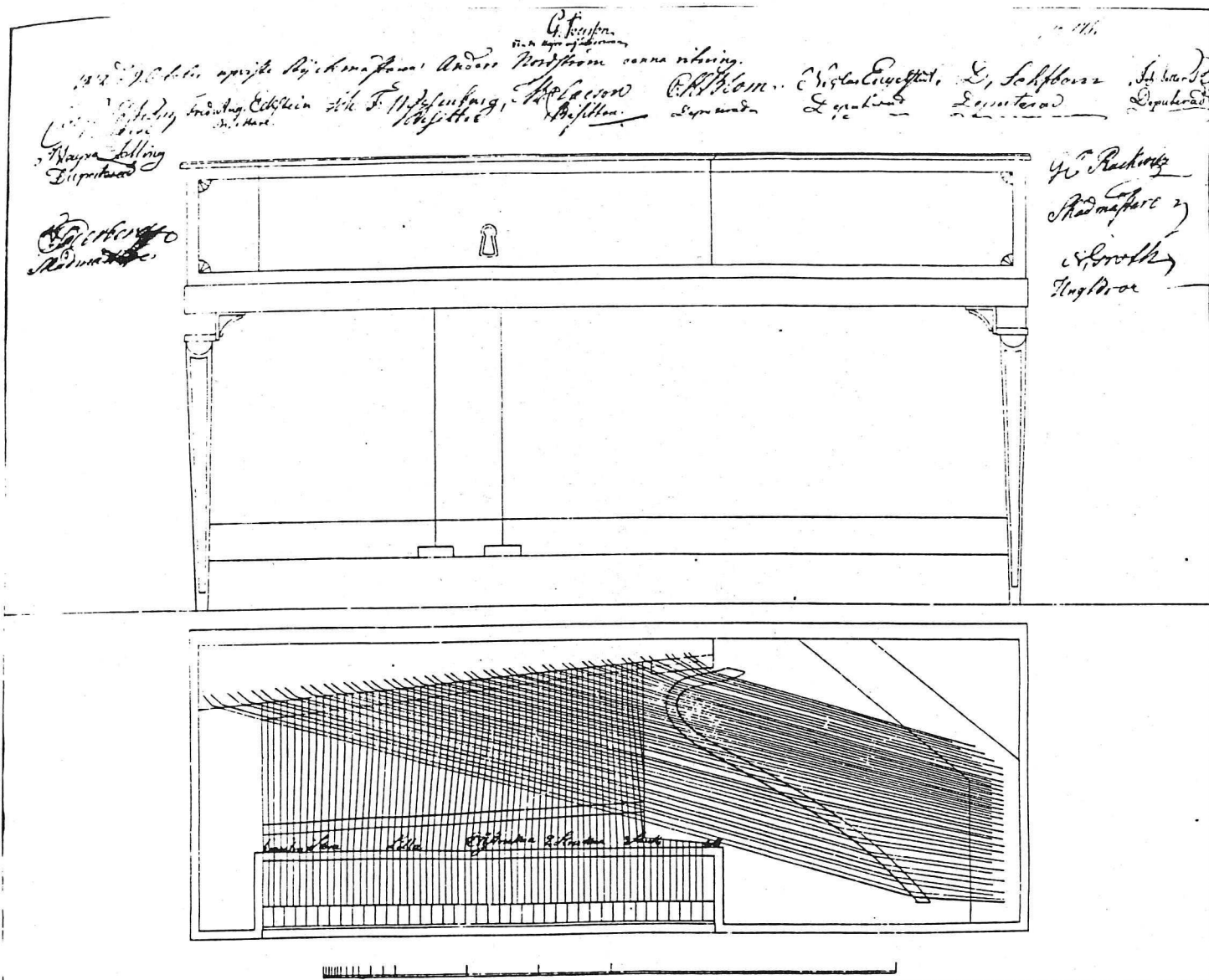
Foto: BNM

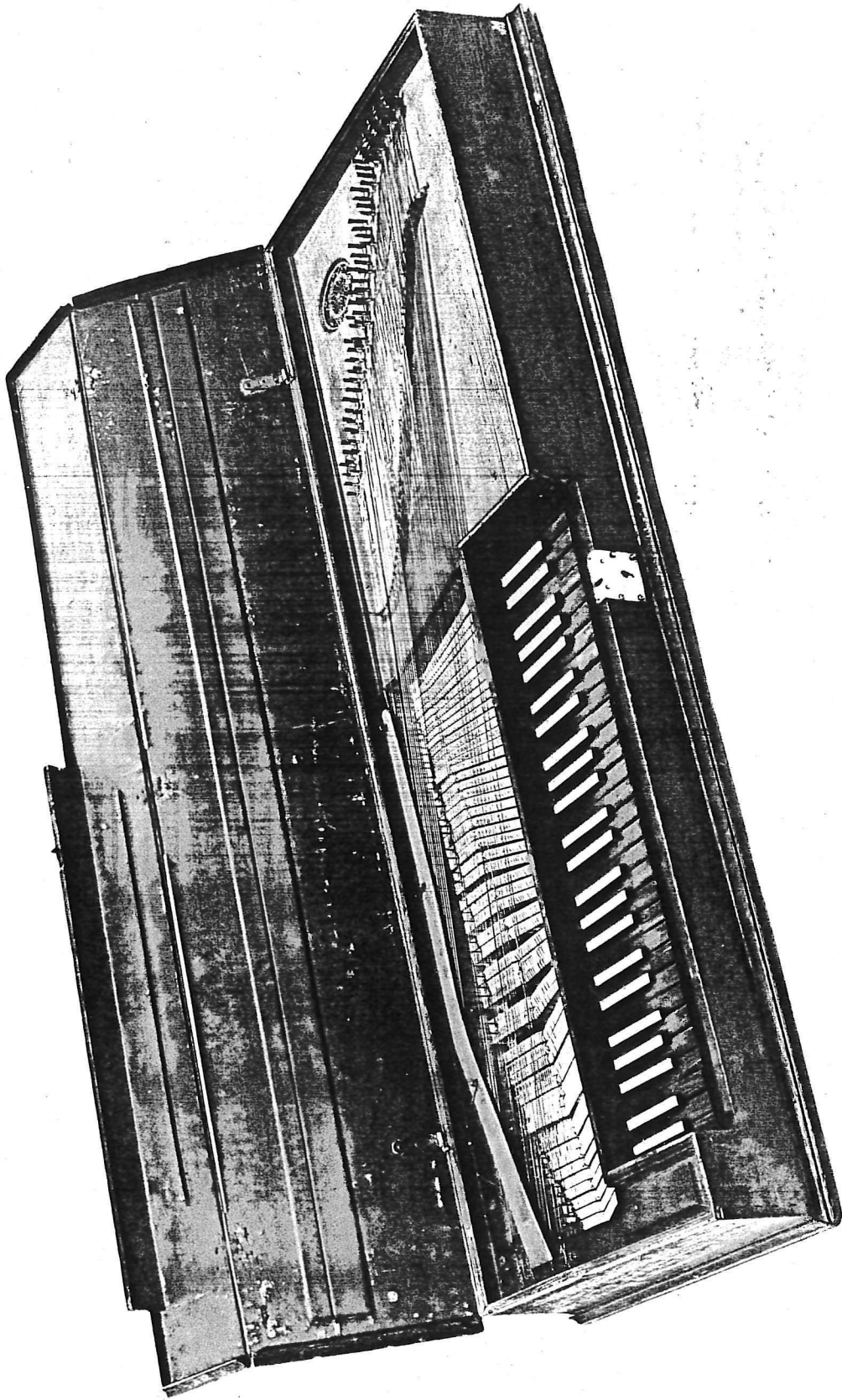

Abb.41: BNM 28/1818

Foto: BNM



Abb.42: BNM Mu 72 (Schmahl, 1790/6)

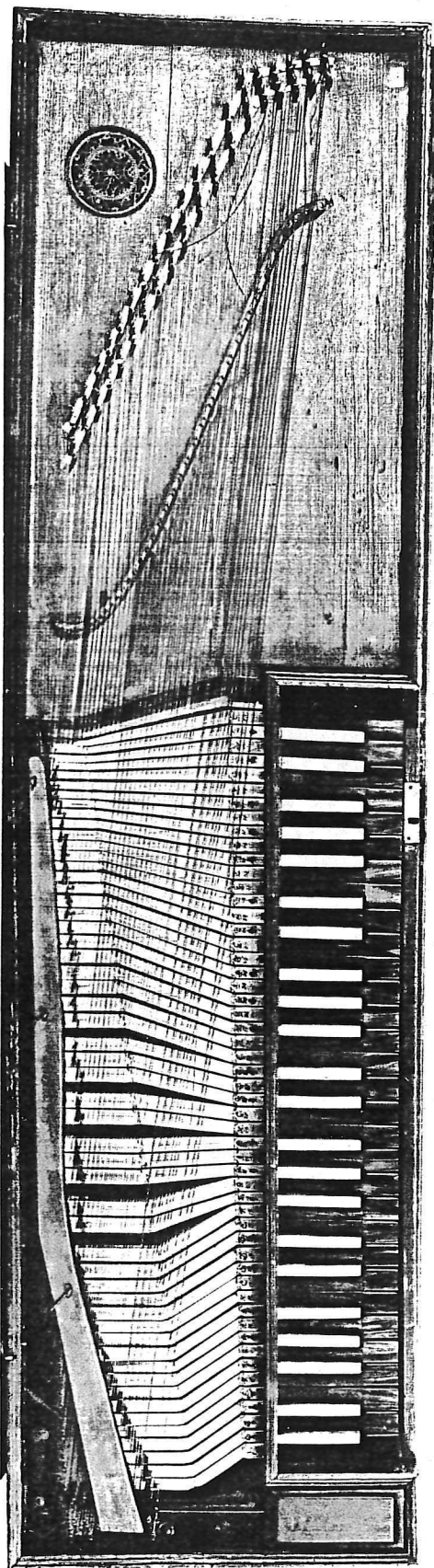

Abb.43: BNM Mu 72

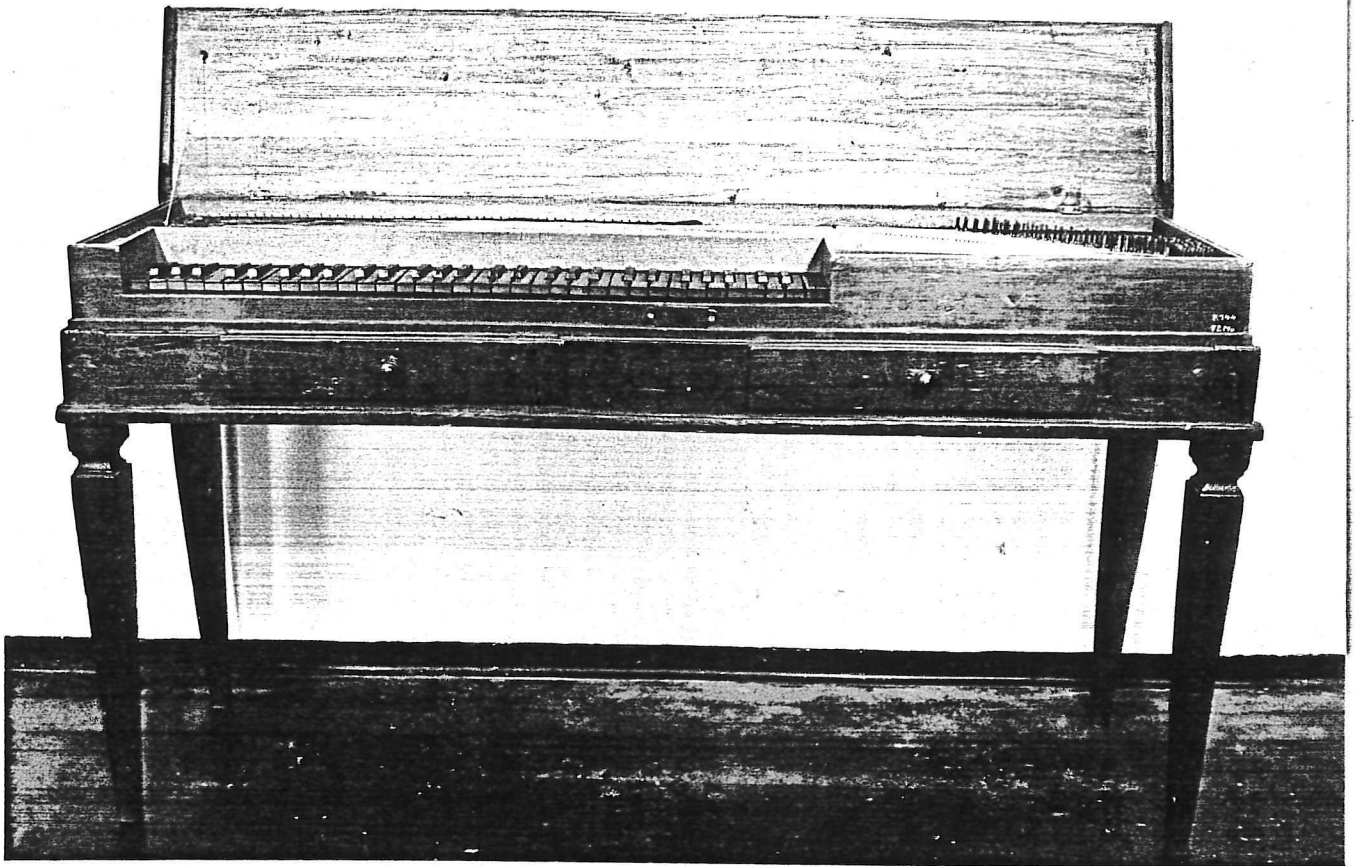

Abb.44: Signatur von BNM Mu 72 (Schmahl)

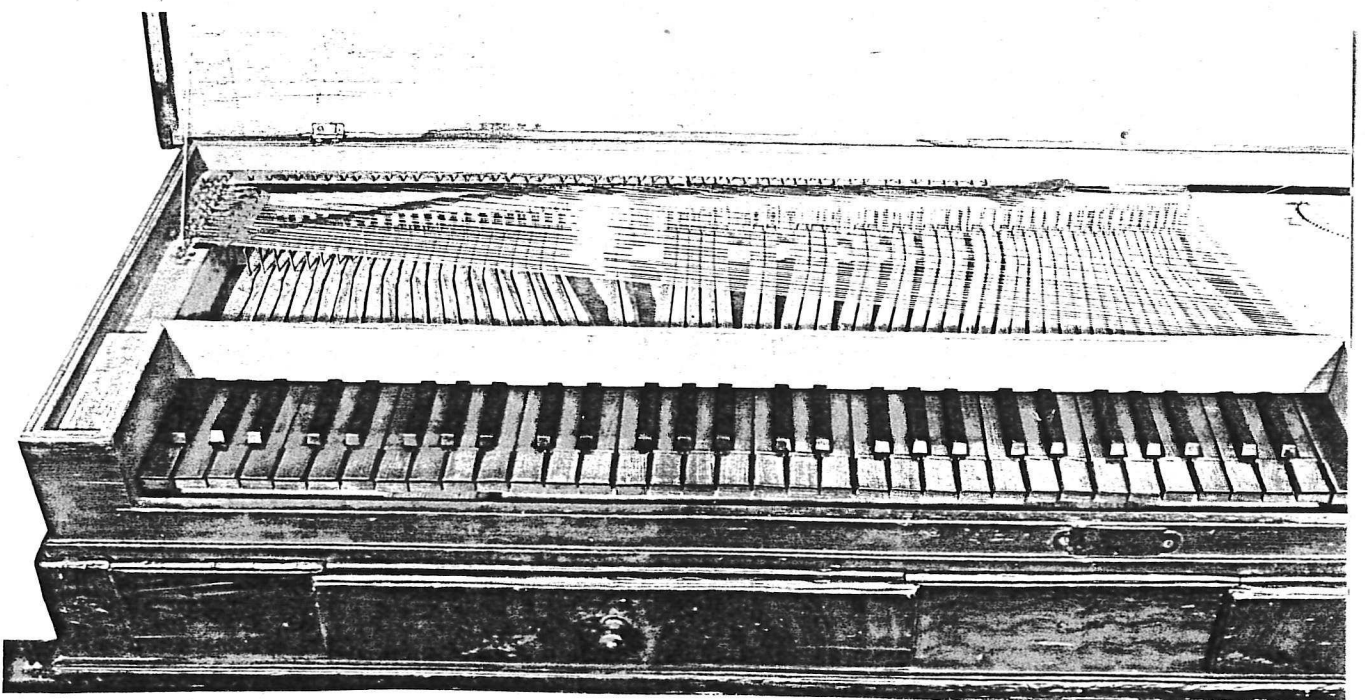

Abb.45 u. 46: Bayer. Staatsbibliothek: Reiseclavichord (Ende 18.Jh.)

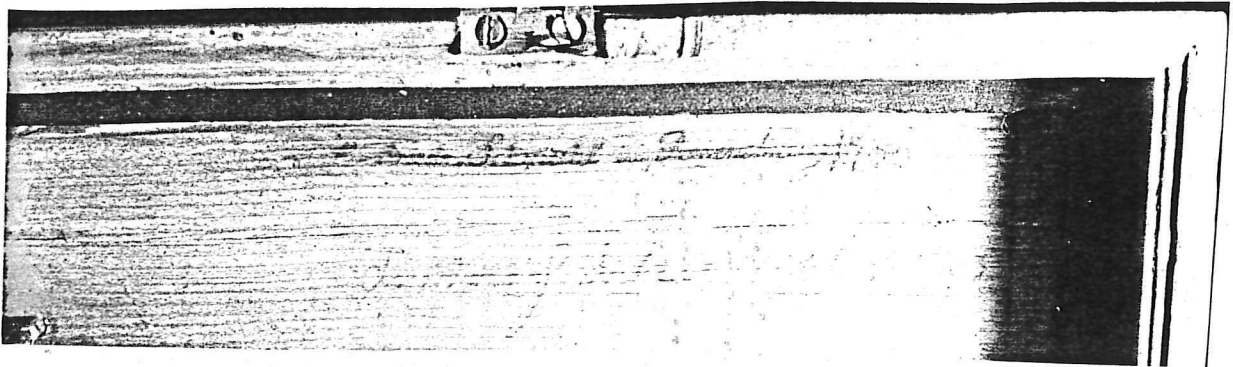

Abb.47: Stuttgart G 4111 (Schiedmayer, um 1780) Foto: Stuttgart

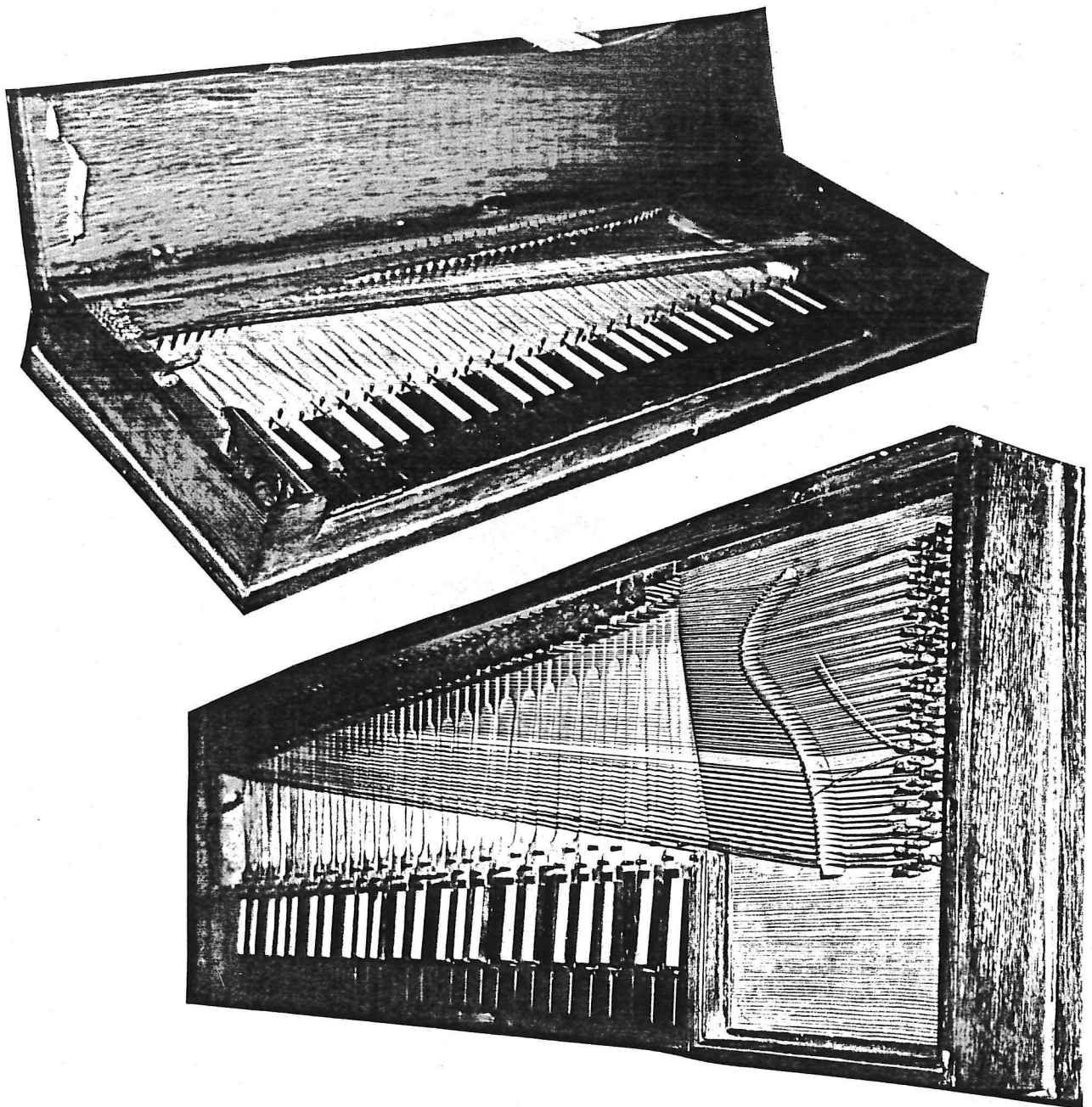

Abb.48: Signatur von Stuttgart G 4111

Foto: Stuttgart

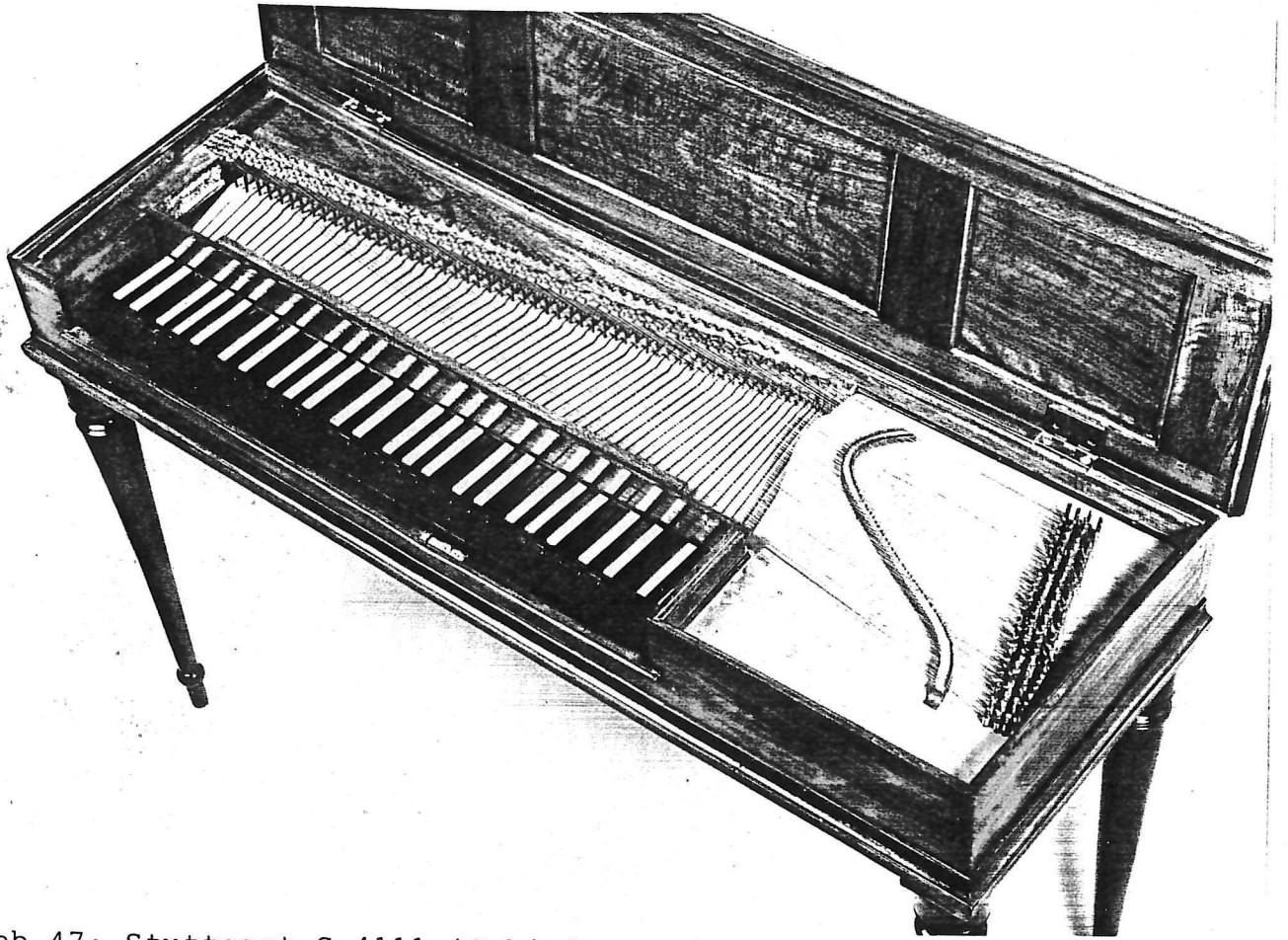

Abb.49:
DM 5393
(Horn, 1796)
Rosette

Foto: DM



Abb.50:
MS 44-2
(Horn?)
Rosette

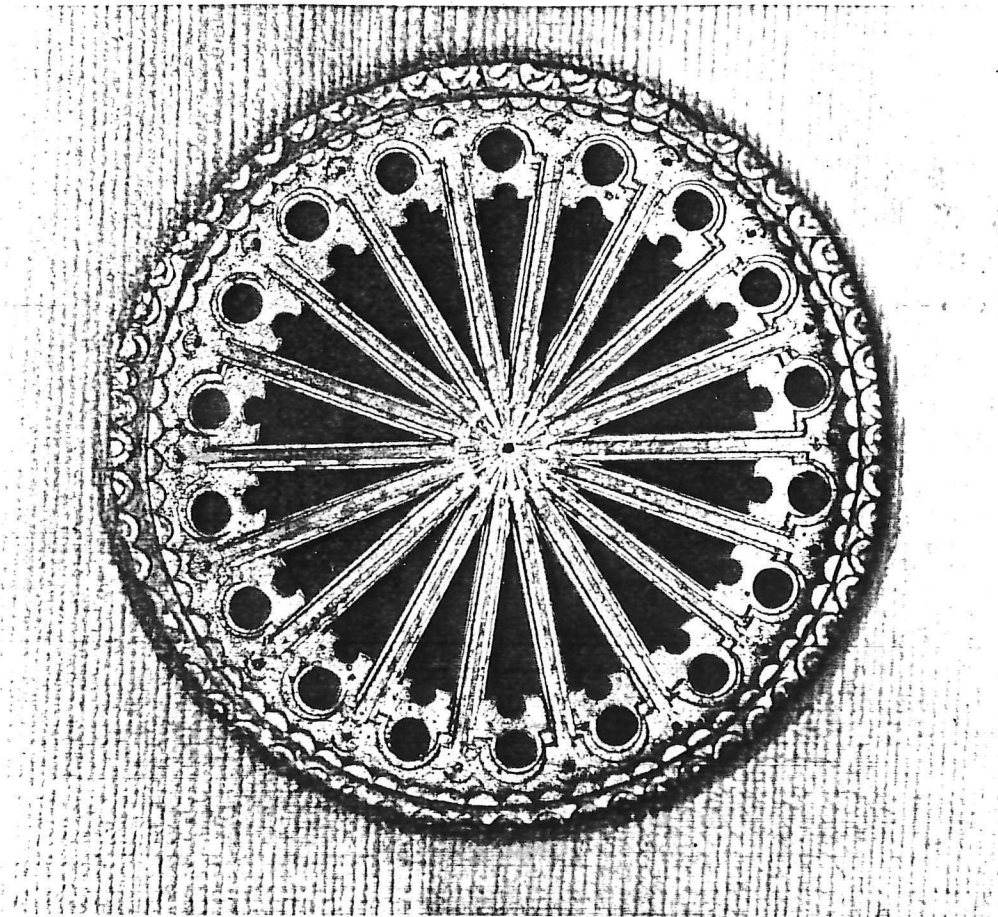

Abb.51: DM 17214 (Gebr.Schmahl, 1812/1815)

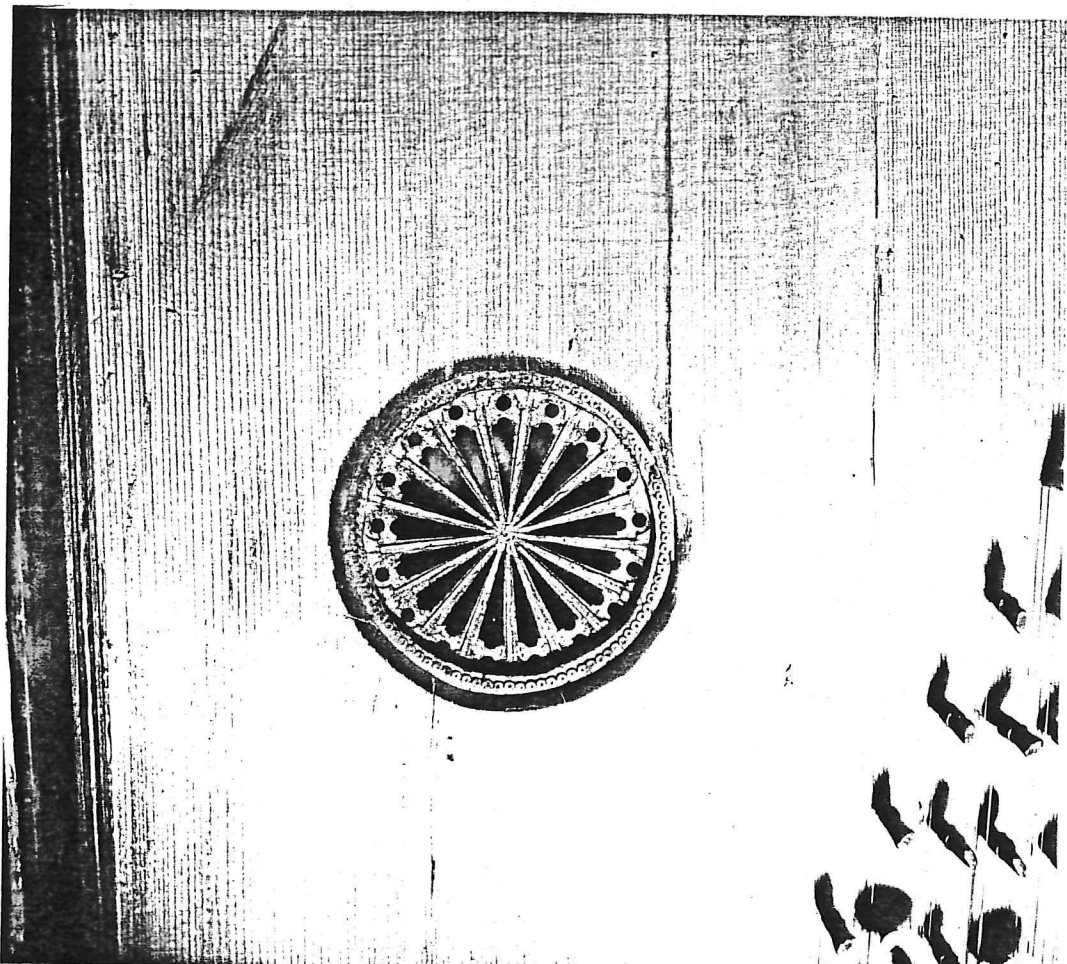

Abb.52.: DM 17214

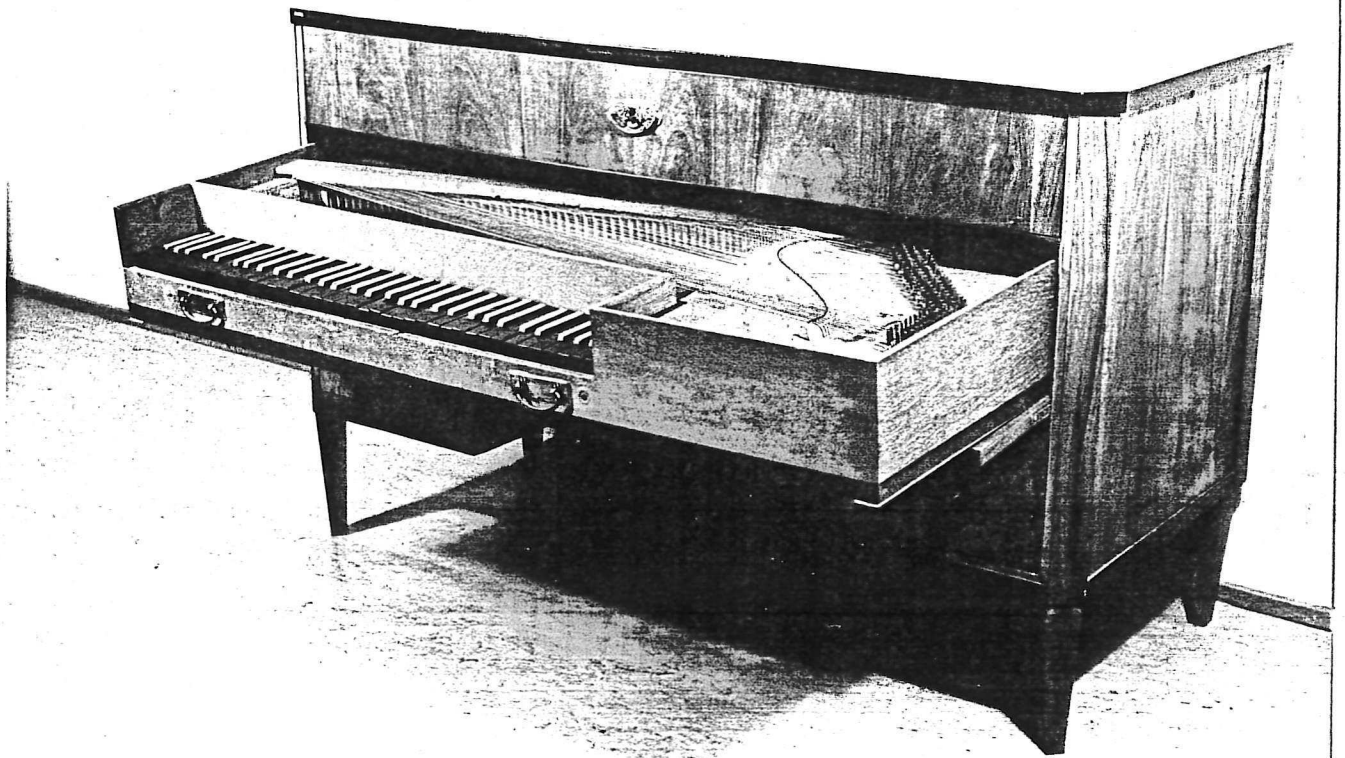

Abb.53.: Signatur von DM 17214

ÜBERSICHT DES BILDTEILS

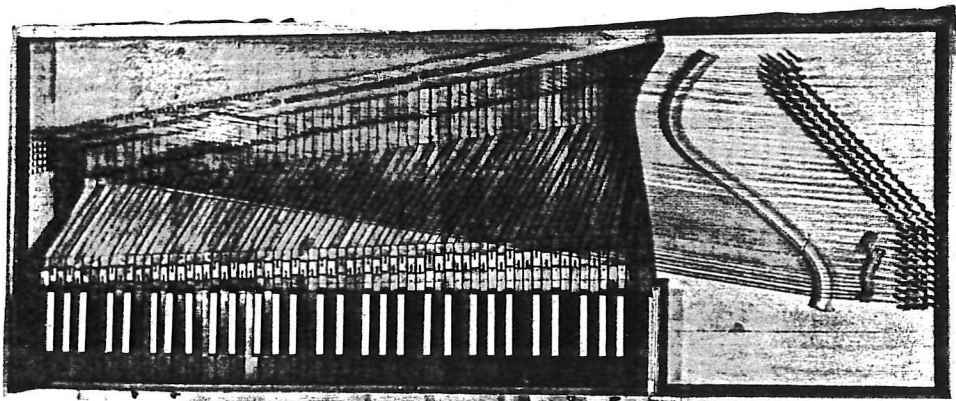
- DM 18165 (deutsch, 2.Hälfte 17 Jh.): III; XXVI; XXXVII; IL.
- DM 5392 (Weiss, 1702): IV; XXVI; XXXVII; IL-L.
- DM 16816 (König, 1739): V; XXVII; XXXVIII; LI.
- DM 20780 (Lemme, 1766): VI; XXVII; XXXVIII; LII.
- DM 5385 (Hubert, 1782): VII; XXVIII; XXXIX; LIII-LIV.
- DM 46116 (Schmahl ? um 1790): VIII; XXVIII; XXXIX; LIV.
- DM 5393 (Horn, 1796): IX; XXIX; XL; LV-LVI; LXXII.
- DM 17214 (Gebr.Schmahl, 1812/15): X; XXIX; XL; LXXIII.
- DM 34072 (Glück ? 19.Jh.): XI-XII; XXX; XLI; LVII-LVIII.
- MS 70-103 (deutsch um 1700): XIII; XXXI; XLII; LIX.
- MS 82-2 (deutsch, Mitte 18.Jh.): XIV-XV; XXXI; XLII; LIX-LX.
- MS 69-15 (deutsch, 2.Hälfte 18 Jh.): XVI; XXXII; XLIII; LXI.
- MS 44-1 (deutsch, 2.Hälfte 18.Jh.): XVII; XXXII; XLIII; LXII.
- MS 44-2 (Horn ? 1772/1797): XVIII; XXXIII; XLIV; LXIII; LXXII.
- MS 44-3 (deutsch, letztes Drittel 18.Jh.): XIX; XXXIII; XLIV; LXIV.
- MS 44-4 (deutsch o.schwedisch, 1810/1820): XX-XXI; XXXIV; XLV;
LXV-LXVI.
- BNM 28/1818 (deutsch, 2.Hälfte 18.Jh.): XXII; XXXV; XLVI; LXVII-LXVIII
- BNM Mu 72 (Fr.Schmahl, 1790/6): XXIII; XXXV; XLVI; LXIX-LXX.
- Staatsbibl.: Reiseclavichord (deutsch, Ende 18.Jh.): XXIV; XXXIV;
XLV; LXX.
- Stuttgart G 4111 (Schiedmayer, um 1780): XXV; XXXVI; XLVII; LXXI.
- Stimmhammer von BNM 28/1818: XLVIII.