

Elisabeth Hofmann, Elizabeth Mavhunga,  
Thorsten Bohl, Felix Maringe, Deborah Diekmann (Eds.)

# Teacher Education in South Africa and Germany

Shared Perspectives on  
National and Global Questions

Results of the Collaborative Work Between  
Wits School of Education and Tübingen School  
of Education

SCHRIFTENREIHE  
DER TÜBINGEN  
SCHOOL OF EDUCATION

TÜBINGEN  
UNIVERSITY  
PRESS 



**SCHRIFTENREIHE DER TÜBINGEN SCHOOL OF EDUCATION**

**BAND 04**

**LEHRERBILDUNG**

**FORSCHUNGSBASIERT. ANWENDUNGSBEZOGEN. VERANTWORTUNGSBEWUSST.**

**HERAUSGEGEBEN VON THORSTEN BOHL, NINA BECK, SIBYLLE MEISSNER**

## Teacher Education in South Africa and Germany



Elisabeth Hofmann, Elizabeth Mavhunga,  
Thorsten Bohl, Felix Maringe &  
Deborah Diekmann  
(Eds.)

# Teacher Education in South Africa and Germany

Shared Perspectives on  
National and Global Questions.

Results of the Collaborative Work Between Wits  
School of Education and Tübingen School of  
Education

### **Bibliografische Informationen der Deutschen Nationalbibliothek**

Die Deutsche Nationalbibliothek verzeichnet diese Publikation in der Deutschen Nationalbibliografie, detaillierte bibliografische Daten sind im Internet über <http://dnb.d-nb.de> abrufbar.



Dieses Werk ist unter einer Creative Commons Namensnennung lizenziert

– Nicht kommerziell – Keine Bearbeitungen 4.0 International Lizenz.

Um eine Kopie dieser Lizenz einzusehen, konsultieren Sie:

This work is licenced under Creative Commons

This license allows reusers to copy and distribute the material in any medium or format in unadapted form only, for noncommercial purposes only, and only so long as attribution is given to the creator.

<http://creativecommons.org/licenses/by-nc-nd/4.0/>

Oder wenden Sie sich brieflich an:

Creative Commons, Postfach 1866, Mountain View, California, 94042, USA.

Die Online-Version dieser Publikation ist auf dem Repositorium der Universität Tübingen frei verfügbar (open access)

The online version of this publication can be accessed via the repository of Tübingen University (open access):

<http://hdl.handle.net/10900/135153>

<http://nbn-resolving.de/urn:nbn:de:bsz:21-dspace-1351536>

<http://dx.doi.org/10.15496/publikation-76504>

Tübingen University Press 2023

Universitätsbibliothek Tübingen

Wilhelmstraße 32

72074 Tübingen

[tup@ub.uni-tuebingen.de](mailto:tup@ub.uni-tuebingen.de)

[www.tuebingen-university-press.de](http://www.tuebingen-university-press.de)

ISBN (Hardcover): 978-3-947251-70-4

ISBN (PDF): 978-3-947251-71-1

Layout und Design: Gabriele von Briel, Tübingen School of Education (TüSE)

Satz: Tübingen School of Education (TüSE) / Sandra Binder (Universität Tübingen)

Druck und Vertrieb: Open Publishing GmbH

Printed in Germany







## Content

### Foreword

Ruksana Osman and Karin Amos . . . . .11

### Introduction

Elisabeth Hofmann, Thorsten Bohl, Elizabeth Mavhunga,  
Felix Maringe & Deborah Diekmann . . . . .13

### 1 Teacher Education in South Africa and Germany: Educational, Societal, and Institutional Backgrounds

#### Chapter 1

Teacher Education in South Africa:  
Transformation from Apartheid to Democratic Intentions  
Felix Maringe & Elizabeth Mavhunga . . . . .21

#### Chapter 2

Teacher Education in Germany:  
Educational Structures, Historical Developments and Academic Challenges  
Elisabeth Hofmann & Thorsten Bohl . . . . .43

#### Chapter 3

How Do Schools of Education Position Themselves Within the South African  
Higher Education Sector: The Case of the Wits School of Education  
Elizabeth Mavhunga, Felix Maringe & Reuben Dlamini . . . . .61

#### Chapter 4

How Do Schools of Education Position Themselves Within the German  
Higher Education Sector: The Case of the Tübingen School of Education  
Elisabeth Hofmann & Thorsten Bohl . . . . .75

#### Chapter 5

Inclusive Education and Diversity in South Africa and Germany –  
Concepts, Policies, and Historical-Political Paradoxes  
Douglas Andrews, Jonas Bischof, Marcus Emmerich & Ruksana Osman . . . . .95

<b>2</b>	<b>Mentoring in Teacher Education</b>	
	Chapter 6	
	Teacher Education in Germany – Mentoring in School Internships	
	Felician-Michael Führer & Tamara Falcone . . . . .	119
	Chapter 7	
	Pre-Service Teacher Professionalization: Becoming a Teacher in South Africa	
	Emmanuel Mushayikwa & Ngonidzashe Mushaikwa . . . . .	131
<b>3</b>	<b>Pedagogical Content Knowledge</b>	
	<b>in Higher Education Teaching and Learning Processes</b>	
	Chapter 8	
	Investigating Abstractness and Motivation as Scaffolding Elements	
	in Biology Lesson Planning. An Explorative Study	
	Eunice Nyamupangedengu & Christoph Randler . . . . .	161
	Chapter 9	
	Global Realities and Economic (Teacher) Education	
	in the Twenty-First Century: A Conceptual Contribution	
	Emmanuel Ojo & Taiga Brahm . . . . .	181
	Chapter 10	
	Shared Perspectives from Two Universities on Teaching Electricity:	
	Lessons for Science Teacher Education	
	Jan-Philipp Burde, John Bradley & Peter Moodie . . . . .	197
	Chapter 11	
	Education for Sustainable Development as a Challenge	
	for Teacher Education: Implementation at the University of Tübingen	
	Diana Grundmann, Matthias Bornemann & Thomas Potthast . . . . .	215
	Chapter 12	
	Education for Sustainable Development (ESD)	
	Classroom Practices: A South African Perspective	
	Caleb Mandikonza & Portia Kawai . . . . .	235
	Authors' information . . . . .	251

## Foreword

Ruksana Osman and Karin Amos

We are humbled to write a foreword to this comparative collection of contributions published under the title *Teacher Education in South Africa and Germany. Shared perspectives on national and global questions*.

We write this foreword with a global pandemic still sweeping across the world, leaving no country untouched. With all the tragedy associated with the pandemic, the economic havoc it has wreaked, and the differences in each country's management of the pandemic and vaccine rollout, there have also been many similarities across the world, especially in relation to how we have cared for each other and come to each other's aid, suggesting that while we have much that separates us, our common humanity brings us together.

This book and the compelling contributions from colleagues on two continents show beautifully how networks and alliances can be expanded based on shared strengths and similar values. They also show how contemporary thematic areas of study—which are vital for the future of education and teacher education, not just in Germany and South Africa, but also globally—can be studied, analyzed and written about with coherence and thoughtfulness.

The post-pandemic environment offers opportunities for emerging alliances and strategic research partnerships at all levels. COVID-19 has levelled the playing field to a certain extent, fundamentally reshaping time and space. A teacher educator in Tübingen can now co-teach a class with a teacher educator from Johannesburg in a way that

<http://dx.doi.org/10.15496/publikation-76387>



was previously impossible. This collapsing of boundaries is less about technological efficiencies and much more about the knowledge project and an agile higher education system.

Universities across the globe face common challenges, but some more than others. As the world reframes itself, they need to seize these opportunities and position themselves as generators of global knowledge. *Teacher Education in South Africa and Germany* shows how this moment has been utilized to produce a book that takes a comparative stance on teacher education in South Africa and Germany, challenging the hegemonic power of knowledge production in teacher education globally. Importantly, in its comparative stance, the book reminds its readers that knowledge and its production are not independent of their context and contextual relevance. The knowledge interests of the contributors clearly show their responsiveness to the local, whilst framing their thinking and actions on a global level.

While this book is about teacher education, there are powerful lessons for schooling and teaching, as the chapters show the potential for advancing teacher expertise—a vital element for classroom learning—whilst also addressing the equally vital socio-economic contexts of schools and classrooms in South Africa and Germany.

Collectively, the work from each of the chapters fosters a critical dialogue about teacher education, teaching and sustainability in South Africa and Germany. The book also shows just how much resonance there is: of challenges, of concerns, of aspirations to improve teacher education and to foster a nurturing environment. Through the collaboration of our two universities, we enrich this environment even more.

This anthology is important for everyone, but particularly for those who find themselves seeking new and inspiring alternatives for teacher education in a post-pandemic world.

## Introduction

Elisabeth Hofmann, Thorsten Bohl, Elizabeth Mavhunga, Felix Maringe  
and Deborah Diekmann

Since its emergence in medieval Europe, the idea of a university has developed and expanded continuously. Today, universities are drivers of progress and innovation as well as hotspots of dynamic international knowledge exchange. Motivated by the aim of providing both learners and educators for a globally interconnected world, universities are massively strengthening their internationalization strategy. They strive to foster global competences, global awareness, and international perspectives in their graduates. Educational governance increasingly supports internationalization in higher education through a growing number of calls for proposals and funding opportunities from national agencies such as DFG (German Research Foundation), NRF (South African National Research Foundation), DAAD (German Academic Exchange Service), or Erasmus Plus (European Exchange Program). Teacher education has made strong advances during the last decade: universities have developed a growing responsibility for providing research-based education for future teachers, combined with reflective practice and learning about social and global responsibilities. Teacher education aims to prepare future teachers for working in a globalized world, so that teachers can equip future generations responsibly for upcoming, often unforeseeable challenges. International cooperation in education has enhanced international comparative educational research at universities, and the need for the comparability of higher education has moved international university rankings into public focus. Large-scale assessments such as PISA and TIMSS have become increasingly prevalent. While for centuries, teacher education took place within strictly limited national domains, higher education institutions of teacher education today acknowledge the

<http://dx.doi.org/10.15496/publikation-76386>



potential of international collaborative or comparative research (see for example Blömeke et al., 2014; Blömeke et al., 2019; Schratz & Vasileios, 2018). Comparative education works with quantitative or qualitative methods, and historical or conceptual research approaches. Comparative approaches enrich the educational landscape by providing researchers and educators with context-specific insight. They also prompt the discussion of systems as a whole, with regard to their historical, cultural, political and economic backgrounds.

The collaboration between the Wits School of Education at the University of the Witwatersrand and the Tübingen School of Education at the University of Tübingen began in 2019 with mutual visits to both universities. Both institutions pursue similar goals: research-based teacher education, support of junior academics, collaboration with faculties or other university-wide institutions, addressing and incorporating urgent societal and global challenges, and working with a broad spectrum of involved disciplines. Researchers from both Schools realized their shared interests and challenges, and began to work on questions of teacher education collaboratively and binationally. Teams were created between researchers from corresponding departments in both institutions.

The concept of this book requires either a comparative research approach between the two locations Wits and Tübingen or a binational approach addressing a joint question. The chapters on hand correspond to the characteristics of international comparative studies, as described by Montanaris (Morén-Alegret, 2012; Wladyka, 2020), with varying foci: international comparative studies cover two or more case studies, they aim to explain rather than analyze, the researchers combine different cultural perspectives in order to understand the processes in both countries, and the collaboration requires academic mobilities.

The results reveal similar challenges and approaches within very different contexts. Local solutions and realizations are put into focus and related to the institutional, content, and process dimension of educational governance (Parreira do Amaral, 2011). Further elements that shape work at institutions of teacher education worldwide are the concepts of pedagogical knowledge (PK), content knowledge (CK), and pedagogical content knowledge (PCK) according to Shulman (Shulman, 1986) and their interrelations. In the international context, Shulman's denominations are established but the national definitions and realizations still require differentiation. In order to provide a basis for understanding the work on hand, the definitions of Pedagogical Content Knowledge in Germany and South Africa are contrasted here.

The German term *Didaktik* refers to the general science of teaching, learning, and education. The German term for PCK, *Fachdidaktik*, describes the mediation of

knowledge structures with special regard for the teaching and learning processes of this knowledge at schools. German Fachdidaktik has developed a strong research base in the last 10 years, critically addressing research design challenges and analyzing methodologies and contents as well as the relationships between skills, competences, learning progress, learning outcomes, and evaluation. Fachdidaktik characteristically develops as a special composite discipline between the subject of education and its specification subject, e.g., mathematics education or history education (Vollmer, 2014; Rothgangel et al., 2021; Riegel & Rothgangel, 2021). Fachdidaktik also relates to meta-levels of learning and education: critical societal, philosophical, or ethical perspectives on contents and methodologies are discussed in an ongoing discourse. Thus, it serves as a continuing corrective for the challenging educational realities of schools and higher education.

In the South African context, the term PCK refers to the conceptualization by Shulman (1986, 1987), responding to the necessity of classroom teachers' understanding and transformation of the content to be taught. Here, Shulman (1986) considered PCK as specialized professional teacher knowledge for teaching content, which is germane to the profession of teaching, allowing difficult and abstract content to be taught in ways that are understandable to learners. The implementation of PCK in South Africa, particularly in the teacher education programs, happens largely through the re-conceptualized grainsize of PCK modelled at a topic-specific level (Carlsen et al., 2019). It is at a topic level that the transformation of content knowledge comes alive: through the interactive use of topic-specific representations, through considerations of what is most important and through an awareness of what is difficult to understand, including common learner misconceptions (Geddis, 1993; Mavhunga & Rollnick, 2013). PCK at the topic-specific level is referred to as Topic Specific Pedagogical Content Knowledge (TSPCK). Learning to teach through TSPCK has enabled teachers and pre-service teachers to develop expertise in one topic at a time and subsequently transfer that competence to develop TSPCK in another (Mavhunga, 2016). This observation makes TSPCK a powerful and promising tool for developing teacher capacity, especially in teaching school disciplines that have been found lacking, with consistent poor learner performance over the years, such as science (Mullis et al., 2020).

TüSE and WSoE expect this volume to deepen scientific collaboration and provide insights into highly specialized research fields in both institutions. By approaching their research questions in binational teams, researchers from South Africa and Germany benefit from the challenge of making their specific educational context understandable and approachable for researchers from other backgrounds.



Education in today's globalizing world is carried out and developed in the context of national or local regulations and globalizing tendencies. While the Global Education Industry reveals tendencies towards equalization (Parreira do Amaral, 2019), emphasis on the value of local solutions has increased in educational work.

This book sheds light on these challenges by addressing how national educational institutions realize international standards and global topics. It is demonstrated how local specifications keep their significance on a globalized educational stage, and how institutions and individual approaches create a balance between the global and the local.

Chapters 1 to 4 introduce the reader to the societal and institutional background of education in South Africa and Germany. In chapter 1, the authors describe and critically discuss the historically evolved settings and constrictions of education in South Africa. Chapter 2 follows with a description of the German educational context. In chapter 3, the authors present the development and self-description of the Wits School of Education in Johannesburg, as well as their contribution to and vision for teacher education in 21<sup>st</sup> century South Africa. Chapter 4 follows with the example of the institutional structures of Tübingen School of Education in Tübingen.

Chapter 5 gives an extensive overview of the history and current challenges of inclusive education in both countries in a joined chapter. It is discussed how historically grown, segregated educational systems are faced with reform aspirations for inclusive education, creating challenges in both countries' educational realities. Changing perspectives on students with special needs are discussed, as well as the paradoxical consequences resulting from concepts of diversity.

Chapter 6 discusses how quality mentoring in Germany's teacher education can be ensured while taking into consideration the complexity and non-linearity of teacher education, as described in multiple professionalization theories. Mentoring is understood as a tool of indirect guidance within individual professionalization processes.

Chapter 7 approaches the development of professional identity and classroom efficacy with Legitimation Code Theory. A gap between school supervision and university mentorship is revealed, showing the need for improvements in the implementation of mentoring in South Africa. Chapters 6 and 7 both reveal the different national struggles surrounding the quality of guidance given to future teachers (see also Heinrich et al., 2019).

Chapters 8 to 10 focus on subject-specific questions in biology education, economic education, and physics education:

Chapter 8 is a collaborative qualitative study analyzing the lesson plans of biology students. The data are analyzed with reference to biology education models from Tübingen and frameworks from Witwatersrand. It is shown that combining educational

methods from Tübingen and Witwatersrand might support students in the field of biology lesson planning.

Chapter 9 identifies and discusses five urgent topics of today's economic reality, demanding changes in the curriculum and pedagogy of economic teacher education.

Chapter 10 approaches the teaching of voltage by referring to the characteristics of electrochemical cells, arguing that physics education in both South Africa and Germany can profit from overcoming narrow subject borders.

Chapters 11 and 12 focus on the topic of Education for Sustainable Development (ESD), showing its urgency and aiming to establish the topic as a pillar across all disciplines. Chapter 11 gives an overview of ESD at the University of Tübingen, describing its governmental regulations as well as its implementation in Tübingen. The authors vote for increased integration of ESD across all subjects, leading to increased competence in the normative-ethical reasoning of all students. Chapter 12 explores how ESD developed from Environmental Education and how it is integrated into the Natural and Life Sciences study program at the University of the Witwatersrand. The authors make a case for a more systematic and implicit integration of ESD.

The variety of subjects discussed in this book reflects the broad spectrum of topics addressed by teacher education in Witwatersrand and Tübingen. Teacher education in both countries works on developing new structures through their Schools of Education. Furthermore, both locations work with classical subjects such as biology, economics, or physics education, and aim to develop the fields of inclusion, mentoring, and Education for Sustainable Development.

This anthology shows the reader the potential of analyzing parallels and differences between teacher education at the University of the Witwatersrand and the University of Tübingen, which both serve as exemplary universities of their respective national contexts. The book further exemplifies functional ways in which North-South institutional collaborations may cultivate vibrant opportunities for knowledge exchange and research that embraces diversity while retaining institution and country identity, fostering inclusive participation by multiple researchers from each institution.

The editors thank all authors for their willingness to collaborate internationally. The authors have demonstrated their openness to the partner university, their ability to connect to a new context, and their ability to work both locally and globally. As a result, both universities are profiting from the academic exchange and resulting insights. Additionally, the work process experienced will continue to benefit teaching, future research, and university life at WSoE and TüSE in the long term.

## Literature

- Blömeke, S., Hsieh, F. J., Kaiser, G., & Schmidt, W. H. (2014). *International perspectives on teacher knowledge, beliefs and opportunities to learn. TEDS-M Results*. Springer. <http://dx.doi.org/10.1007/978-94-007-6437-8>.
- Blömeke, S., & Olsen, R. V., (2019). Consistency of results regarding teacher effects across subjects, school levels, outcomes and countries. In *Teaching and Teacher Education*, 77(7), 170–182. <https://doi.org/10.1016/j.tate.2018.09.018>
- Carlson, J., Daehler, K. R., Alonzo, A., Barendsen, E., Berry, A., Borowski, A., ..., & Wilson, C. (2019). The refined consensus model of pedagogical content knowledge in science education. In A. Hume, R. Cooper & A. Borowski (Eds.), *Re-positioning pedagogical content knowledge in teachers' knowledge for teaching science*. Springer.
- Geddis, A. N. (1993). Transforming subject-matter knowledge: The role of pedagogical content knowledge in learning to reflect on teaching. *International Journal of Science Education*, 15(6), 673–683.
- Mavhunga, E., & Rollnick, M. (2013). Improving PCK of chemical equilibrium in pre-service teachers. *African Journal of Research in Mathematics, Science and Technology Education*, 17(1–2), 113–125.
- Morén-Alegret R., & Wladyka D. (2020). *International Immigration, Integration and Sustainability in Small Towns and Villages. Migration, Diasporas and Citizenship*. Palgrave Macmillan. [https://doi.org/10.1057/978-1-137-58621-6\\_4](https://doi.org/10.1057/978-1-137-58621-6_4)
- Mullis, I. V. S., Martin, M. O., Foy, P., Kelly, D. L., & Fishbein, B. (2020). *TIMSS 2019. International Results in Mathematics and Science*. <https://timssandpirls.bc.edu/timss2019/international-results/>
- Parreira do Amaral, M., Steiner-Khamsi, G., & Thompson, C. (Eds.) (2019). *Researching the global education industry. Commodification, the market and business involvement*. Springer. <https://doi.org/10.1007/978-3-030-04236-3>
- Parreira do Amaral, M. (2011). *Emergenz eines internationalen Bildungsregimes? International Educational Governance und Regimetheorie* [Emergence of an international education regime? International Educational Governance and Regime Theory]. New Frontiers in Comparative Education, vol. 1. Waxmann.
- Rothgangel, M., Abraham, U., & Bayrhuber H. (Eds.) (2021). *Lernen im Fach und über das Fach hinaus: Bestandsaufnahmen und Forschungsperspektiven aus 17 Fachdidaktiken im Vergleich* [Learning in and beyond the subject. Stocktaking and research perspectives from 17 subject didactics in comparison]. *Allgemeine Fachdidaktik (Vol. 13)*. Waxmann.
- Riegel, U., & Rothgangel, M. (2021). Research designs of subject-matter teaching and learning. *RISTAL. Journal of Research in Subject-Matter Teaching and Learning* 4(1), 1–17, <https://doi.org/10.23770/>.
- Schratz, M., & Symeonidis, V. (2018). Transnational perspectives of transformative teacher learning in an emerging Europe. *CEPSj*, 8(3), 7–12. <https://doi.org/10.26529/cepsj.593>
- Shulman, L. S. (1986). Those who understand: Knowledge growth in teaching. *Educational Researcher*, 15(2), 4–31.
- Shulman, L. S. (1987). Knowledge and teaching: Foundations of the new reform. *Harvard Educational Review*, 57(1), 1–22.
- Vollmer, H. J. (2016). Fachdidaktik and the development of generalised subject didactics in Germany, *Éducation et didactique*, 8(1), <http://journals.openedition.org/educationdidactique/1861>.
- Waldow, F. (2016). Das Ausland als Gegenargument: Fünf Thesen zur Bedeutung nationaler Stereotype und negativer Referenzgesellschaften [The foreign country as a counterargument: Five theses on the importance of national stereotypes and negative reference societies]. *Zeitschrift für Pädagogik*, 62(3), 403–421.
- Wiseman, A. W. & Baker, D. (Eds.) (2008). *The worldwide transformation of higher education*. International Perspectives on Education and Society (Vol. 9). Bingley, JAI Press.

**Teacher Education in South Africa and Germany:  
Educational, Societal, and Institutional Backgrounds**



# Chapter 1

## Teacher Education in South Africa: Transformation from Apartheid to Democratic Intentions

Felix Maringe and Elizabeth Mavhunga

*In this chapter, we examine the notion of teacher education in South Africa, exploring its roots in the highly contentious and divisive era of Apartheid and the changes that have taken place since the attainment of democracy in 1994. We argue that teacher education is central to the training and education of good teachers, who are the key custodians of quality education. We further suggest that the transformational ambitions of the post-democratic government have only been achieved to a limited extent in teacher education. Much of the transformation has been symbolic, in terms of new policy formulations aimed at expanding the access of previously disadvantaged groups of university aspirants to teacher education programs. The same effect is observed with respect to the revised funding formulas designed to enable poor students to surmount financial barriers hindering their participation. Despite these important changes, the curricula and pedagogies of teacher education have largely remained unchanged, leading us to conclude that the fundamental epistemic injustices of the past continue to be reproduced and entrenched in South Africa's teacher education programs.*

*The chapter begins with a conceptual discussion of various ideas surrounding colonization, decolonization, coloniality and decoloniality to lay a foundation for understanding the argument about the sheer symbolism post-democratic transformation. It then discusses the highly divisive nature of apartheid teacher education before analyzing a range of transformative discourses and drivers in the post democratic dispensation. The chapter concludes by suggesting a need to move beyond symbolism and to begin questioning epistemic issues of the curriculum and pedagogies of teacher education in South Africa.*

<http://dx.doi.org/10.15496/publikation-76375>



## 1 Introduction

Teacher education is at the heart of the success and effectiveness of schools in any country (Bush, 2019). One factor that contributes to successful school systems and learner outcomes is the availability of good teachers. These are products of teacher education through both the in-service and pre-service programs. Evidence suggests that good teachers constitute the greatest influence on the success of schools and learner outcomes (Darling-Hammond, 2007). In this chapter, we look at the historical development of teacher education in South Africa, its current state, and the opportunities and challenges it faces. We argue that teacher education in South Africa, like the rest of the university sector, continues to be based on colonial structures that are ill-placed to confront the context-specific challenges it faces. While substantial transformation has taken place since 1994, the year South Africa replaced its Apartheid government, little has happened to change the curriculum of teacher education. We argue in this chapter that if the curriculum remains unchanged, everything else represents a superficial transformation. We begin by briefly discussing notions like colonization, decolonization, coloniality and decoloniality to establish a basis for this argument.

## 2 Colonization and coloniality

Colonization was part of the empire-building project, which was carried out for economic, religious, and military reasons largely by the industrializing nations of Europe. Colonization means the occupation of and rule over another country to expropriate its resources. The so-called ‘voyages of discovery’ of the 15<sup>th</sup> to the 18<sup>th</sup> centuries were the preface to colonization, as these were meant to ‘discover’ the best places on earth in which to settle, and from which to extract resources, in service of the rapidly industrializing empire. By every means possible, including by persuasion, conquest, false promises and cheating, colonization resulted everywhere in the occupation, subjugation, and exploitation of – and, above all, epistemic violence towards – the indigenous populations (Fanon, 1965; Mbembe, 2001).

While the notion of imperialism is often conflated with that of colonization, it is important to make a distinction: while the former involves the expansion of influence through the use of military force and other power resources, the latter involves setting up colonies or settlements to benefit the colonizing country politically and economically. The reasons for the creation of empires and colonies are economic, military, re-

ligious, and exploratory. There has been an underlying belief that the whole world would benefit from the civilizing influence of Western countries (Maravanyika, 1985). Historically, the age of enlightenment was all about opening the world's eyes to the edifying influence of Christianity and modernism. This, perhaps, was the greatest error of judgment, based on the assumption that the rest of the world would, under Western values, be a better place. Thus, wherever colonialists went, they made little or no attempt to understand the values, economic organization, technological capital, knowledge, education or religions of the indigenous peoples. Instead, they were assumed to be backward and in need of salvation, needing to be rescued from the paths of self-destruction they were following (Maravanyika, 1985).

Reverend Wilder, who headed a mission station in Zimbabwe, once wrote that the purpose of the mission station was to demonstrate to the indigenous Blacks that there was something more worthwhile to do in life than to drink beer and make babies (Maravanyika, 1985). As we shall see later, the strategies of displacement and disengagement were utilized to erase indigenous people's values and identities, replacing these with the values of the colonizers. In the educational process, for example, local indigenous languages were not only despised and neglected, but also systematically removed from the curriculum and replaced with the colonizers' languages. Effectively, the indigenous populations were forced to use Western lenses to see and understand themselves (Mbembe, 2001). This resulted in local people seeing themselves as inadequate, underdeveloped, and dependent – as unfinished business. The only way to overcome these deficits was to embrace the colonizers' way of being, ridding themselves of anything that even hinted at their indigenous origins (Fanon, 1965).

However, colonialism was resisted, even though for a long time, the colonizers used their political, military, and legal might to suppress any opposition. The growth of socialism and communism, which offered a critique of capitalism (Chachage & Chachage, 2004), provided ideological support to the dissenting voices in the colonies. So too did the increasing military influence of socialist and communist Russia and China, through whose support dissenting voices were militarized. This was done to support armed struggle in the colonies, which resulted in the achievement of political independence in the late fifties and sixties. It was not until 1994 that South Africa gained democratic freedom – the last country in Africa – from oppressive and divisive rule by the minority groups who had settled in the country, broken ties with their own country of origin, and become a power unto themselves. The attainment of the democratic rule was indeed the first phase of the decolonization process.



## 2.1 Neo-colonialism and coloniality

The most important lesson to come out of this initial victory in the decolonization process is that political independence, sovereignty, self-rule, and democracy do not by themselves erase colonialism. They constitute a necessary step, but are by no means the final step in the decolonization process, if there is a final step at all. By and large, colonizing countries do not simply relinquish control. They become so intricately connected to their colonies, emotionally, economically, politically, religiously, and also militarily. In a sense, they become dependent on their former colonies, to the extent that they will do everything possible to maintain the status quo.

Neo-colonialism is the practice of using economics, globalization, cultural influence, and conditional aid, rather than direct military and political control, to maintain the colonial condition (Chachage & Chachage, 2004). The Commonwealth, the World Bank and IMF, the Internet and World Wide Web are a few examples of structures that have, advertently or inadvertently, maintained the imbalances of power across the world and the economic exploitation of poor nations for the benefit of richer nations (Hoyos & Angel-Urdinola, 2017). Although Kwame Nkrumah (1956) in Mazrui (2004) defined neo-colonialism as the last stage of imperialism, he noted that it was perhaps the most dangerous, as it often implies power without responsibility and results in the widening of the gap between the rich and poor nations, frequent social upheavals that lead to economic collapse, and sometimes military conflicts in the former colonies.

Coloniality is essentially the condition that results from the neo-colonial experience. It is the tendency of a former colony to remain within the colonial matrix of power and influence. Quijano (1998) emphasizes that coloniality describes the living legacy of colonialism in contemporary societies, the continued adherence to the colonizers' canons, and the entrenchment of power differentials in societies across the globe. Quijano has given us two main forms through which this coloniality of power is evidenced and maintained in the post-colonial condition.

Essentially, the coloniality of power is a complex matrix of hierarchies through which power is distributed and allocated. For example, power is effectively reproduced and allocated along the gender binary, where men, in many parts of the world, are accorded higher status and social leadership. It is therefore no coincidence that almost 95% of the world's presidents and prime ministers are male. Likewise, in South Africa, 20 of the 23 university Vice Chancellors are male. Based on beliefs about innate abilities and inequalities within the human species, hierarchies and privileges in higher education still tend to trace the contours of gender. Extending the work of Quijano, Maldo-

nado Torres (2011) describes how coloniality supersedes and entrenches colonialism. He states that:

- » Coloniality ... refers to long-standing patterns of power that emerged because of colonialism, but that define culture, labour, intersubjectivity relations and knowledge production well beyond the strict limits of colonial administration. Thus, coloniality survives colonization. It is maintained alive in books, in the criteria of academic performance, in cultural patterns, in common sense, in the self-image of people, in aspirations of self and so many other aspects of our modern experience. In a way, as modern subjects, we breathe coloniality all the time and every day.

## 2.2 Coloniality of knowledge

This comprises two complementary elements. The first is the continued denial of knowledge production to the conquered people. The systems that recognize excellence, such as university league tables, base their standards on the practices of the most prestigious Western universities, such as Harvard, MIT, Oxford, and Cambridge. Journals that publish knowledge created in the former colonies are disregarded and ranked so low that they become invisible in the academic hierarchy. The second element is the dominance of the Western knowledge canon, which is perpetuated through consolidating and entrenching the so-called dominant world views (Quijano, 1998), prescribing what we teach, how we teach, and how we assess. For example, even though African indigenous populations had strong and effective leadership and knowledge systems, little to no mention is made of these in many leadership and management courses taught at local universities. In knowledge production mechanisms, the apprenticeship model for training doctoral students dominates our practices, based on the Western belief in the individualization of expertise and its location in specific individuals who wield power in our universities. However, many African societies embrace a cooperative belief system, such as Ubuntu (Mugumbate & Chereni, 2020), which teaches that people exist because of others, or the famous Ujamaa philosophy found in many East and Central African countries, in which community and national development efforts are delivered by groups of people rather than individuals. Critical to these afro-centric philosophies are issues of communalism, respect, and the prioritization of human dignity. Possibilities of collaborative doctoral research could be explored as a potentially viable approach to new, transformative knowledge-making in higher education institutions.

### 2.3 Coloniality of being

The coloniality of being is a concept used to describe how dominant cultural systems reproduce, entrench, and subjugate other cultural systems, inducing people to follow the patterns of their cultural practices, which define and reproduce their sense of being (Maldonado-Torres, 2007). Through language, cultural artefacts, technology, music, entertainment, amongst other cultural dimensions, the essence of Western being holds sway over all other ways of being. When a rural student comes to join our universities, they must, first and foremost, adjust to the alienating Western culture on which the university culture is based. They have to shed their rural culture and wear new designs, speak in a new way, eat new types of foods, and be seen using the latest smart technologies. Meanwhile, the university itself does everything to align its values, strategies, and ambitions with those of the most successful Western universities to cement their position in the global hierarchy of academic excellence. The ongoing COVID-19 pandemic has clearly shown a new coloniality in the way the world mitigates the impact of epidemiological disasters.

### 2.4 Decolonization and decoloniality

Earlier we noted that colonization began as soon as settlers occupied indigenous land. The first phase of decolonization therefore ended with the attainment of political independence, sovereignty, and democracy in previously colonized nations. However, as we have seen, such countries enter the more dangerous phase of neo-colonialism, orchestrated this time not by military force, but by use of post-modern institutions and ideologies that force post colonies to behave. We do not know, nor can we speculate, how long this process of coloniality will last. The process of actively engaging with coloniality is what is referred to as decoloniality. Ndlovu-Gatsheni (2020) states, for instance, that while coloniality is a project of death, decoloniality is a project of life. While coloniality refers to the enduring patterns of power and injustices established by colonization through various forms of epistemicide, decoloniality finds ways to bring back epistemological justice into Higher Education.

## 3 A brief history of teacher education in South Africa

The apartheid policies of racial segregation and white supremacy resulted in separate and differentially resourced education systems for Blacks and Whites. Teacher

education for Blacks in the apartheid era took place in Bantustan establishments and provincial establishments, in about 102 public teacher training colleges. These institutions were not exposed to the best practices in teacher training (Cross, 1986). For example, prior to 1994, trainees for the Black education sector were only required to start training with a Standard 8 school leaving qualification, which was barely a post-primary-level qualification. In 1995, the National Teacher Education audit found that almost 40% of teachers in South Africa were underqualified or unqualified, giving rise to a demand for in-service teacher education CPD to improve the quality of teachers.

Major changes, alongside other changes across different sectors, were introduced in 1994. The responsibility for teacher education was shifted to the 23 universities that were constituted partly through mergers and the upgrading of former Technikons (these were formerly technical and polytechnical institutions) to university status. This meant that the responsibility for teacher preparation was no longer in the hands of colleges, but in those of the universities. Currently, all teacher education programs are housed either within Faculties of Education or, in some cases, in Faculties of Humanities and Social Sciences within the universities. The deans of faculties and heads of schools of education provide the administrative leadership for teacher training in South Africa. There are two major routes in universities for students to gain a teaching qualification. The first and more common of these is the four-year Bachelor of Education Degree (Department of Higher Education and Training, 2015). Students taking this route enter universities through the Matric school leaving certificate, a five-year secondary leaving certificate required by all universities for undergraduate studies. The second route is through the PGCE (Post Graduate Certificate in Education), a one-year full-time or two-year part-time program open to graduates with combinations of school teaching subjects in their undergraduate degree programs.

### 3.1 Structure of the school system in South Africa

Education in South Africa is governed by two departments: the Department of Basic Education (DBE) and the Department of Higher Education and Training (DHET). The DBE is responsible for primary and secondary schools, while the DHET has responsibility for all post-school education, including universities and Technical and Vocational Education and Training (TVET) colleges (van der Berg & Hofmeyr, 2018)

The DBE oversees public and independent (private) primary and secondary schools, early childhood development centers (ECD), and special needs schools. The DHET

deals with further education in the TVET sector, Community Colleges, Adult Basic Education and Training (ABET) centers, and universities (van Der Berg and Hofmeyr, 2018).

Beyond the national structures, education in South Africa is administered through nine provincial administrations representing the nine provincial governments in the country. These provincial governments basically implement National strategies and focus on local specific contexts. For example, a major aspect of provinces is that some are largely rural, while others are urban metropolitan provinces. Rurality and urbanity in the school systems demarcate contours of privilege and deprivation, which unfortunately are, to a large extent, racially linked. In that context, learner outcomes and opportunities in South Africa continue to be mitigated by the legacies of Apartheid (Moletsane, 2012).

### 3.2 Teacher training types in South Africa

Band	Classes / Grade	Training Phase
Pre GED	Grade 000	Early childhood education
	Grade 00	
GED Foundation	Grade 0 / R	Foundation Phase Training
	Grade 1	
	Grade 2	
	Grade 3	
GED Intermediate	Grade 4	Intermediate phase Training
	Grade 5	
	Grade 6	
GED Senior	Grade 7 (highest primary class)	Senior Phase training
	Grade 8	
	Grade 9	
FET	Grade 10	FET Phase
	Grade 11	
	Grade 12 (highest secondary class)	

*Table 1 Teacher Training levels in South Africa: KEY: GED = General Education; FET = Further Education and Training*

The phased structure of training is assumed to reflect traditional psychological and physical levels of learners' development. However, whether or not the program structuring in teacher education contributes to the reproduction of colonial edifices of power is a question worth serious interrogation (Chisholm, 2020).

### 3.3 Academic models of teacher education

There is no discernible pattern in the master's level training of South Africa's teacher education. B.Ed. graduates generally find employment in schools and, after a few years of service, if they passed their undergraduate degrees with good marks, can enroll in the B.Ed. Honors one-year full-time or two-year part-time program. The Honors program is usually discipline-focused and, in some universities, has a small research component. It is generally meant to deepen students' knowledge of fundamental disciplines and to train them in knowledge production (Department of Higher Education and Training, 2015).

There is a variety of master's level qualifications in schools of education and at different universities in South Africa. The most prominent one is the M.Ed., which offers specializations in different subject disciplines, together with a substantial research report or dissertation. The terms dissertation and thesis are not sufficiently differentiated in the South African context, as they are used interchangeably or with overlapping meanings across different institutions. It is also important to note that the M.Ed. is not a teaching-specific qualification. It is located within the broader field of education. Students can opt to work in diverse areas such as curriculum studies, ICT in education, educational leadership, language in education, mathematics, and science education, amongst others. There is a shortage of participation in some areas, such as Early Childhood Development, and this tends to limit the capacity and pipeline to doctoral-level studies in such areas.

### 3.4 Indicative program structure in South Africa's pre-service teacher education

The B.Ed. degree is based on a concurrent study of subject-specific content and pedagogical approaches. Students generally study two teaching subjects to a level that is equivalent to the 3<sup>rd</sup> year level of study in universities in South Africa (Davids & Waghid, 2020). In other words, while the B.A. English degree is usually a four-year degree, the B.Ed. student is expected to finish with a content-level equivalent to the third year of a four-year B.A. or B.Sc. degree. The other year is made up through study of subject pedagogies in the two teaching subjects and through school-based experience. This teaching experience, frequently referred to as Teaching Practice (TP), is spread across

the years of study. Typically, B.Ed. students spend an average of 21 weeks in schools across the four-year period of study, three in the first year and six each in the second, third and fourth year of study. On the other hand, PGCE students are expected to spend an average of 10 weeks in schools during their time in training. No study has been undertaken to compare the quality of teachers produced through these two very different pathways. This could be a subject for further research in this joint project.

### 3.5 Teacher certification and registration in South Africa

Once a trainee has completed their degree program in the B.Ed. or PGCE, they are classified as a fully / professionally qualified teacher. Upon qualifying, teachers cannot practice in schools before registering with the South African Council of Educators (SACE). In order to register, prospective fully qualified teachers have to submit the following documentation:

- ▶ A fully completed SACE application form
- ▶ Certified copies of the NSC / Matric certificates
- ▶ Certified copies of academic transcripts
- ▶ National ID certificates
- ▶ Proof that the school they wish to teach at is registered by the DBE
- ▶ Offer of employment letter by a school

It is important to note that teachers in South Africa do not have to undergo a period of induction as newly qualified teachers to become fully qualified. This is another area where interesting research could be conducted, specifically on the value of the induction into teaching before full licensure.

## 4 Emerging discourses of transformation in teacher education

Four discourses characterize the South African teacher education terrain. These are decolonization, inclusive education, teacher quality, and the role of teacher unions.

### 4.1 Decolonization

As discussed earlier, decolonization came to the fore in South Africa with the Rhodes Must Fall protests led by the University of Cape Town, as well as the University of

the Witwatersrand Fees Must Fall protests, in 2015 and 2016 respectively. These protests effectively became movements and the rallying call for the decolonization of higher education in South Africa. Students made three substantial demands:

The abolition of fees in order to allow poor but deserving students to access university education. It was felt that fees placed a limit on democratized participation by all deserving students. Although fees have not been abolished, the government came up with “learn now pay later” financial models operated through several bursary schemes. To qualify for such schemes, deserving students had to demonstrate that they came from specific minimum income threshold households. However, once these students are employed and their salary has reached a certain level, they are expected to repay their loans.

The maintenance of quality in higher education. Students were very clear that the democratization of higher education was not to downgrade the quality of educational provision. Beyond this, there was not much nuance in the understanding shared by the movements about the meaning of quality. However, while universities have grappled with this in different ways, the maintenance of a university's standing in the global rankings has been considered a key indicator of high quality. In that sense, it can be argued that South Africa has maintained its status as the jewel of African higher education, as it has the highest number of universities consistently ranked in the top 500-1000 of globally eminent institutions, according to several ranking tables such as the Times Higher Education, the QS World University Rankings, and the Shanghai World University Rankings. The Universities of Cape Town (UCT), Witwatersrand (Wits), Stellenbosch (US), Pretoria (UP), KwaZulu Natal (UKZN), and more recently the University of Johannesburg (UJ), constantly feature highly in the Times Higher Education (THE) lists, the QS Rankings, and the Shanghai Rankings. The Times Higher Education (THE) consistently ranks UCT, Wits and US as Africa's top three universities. Africa's top world-class universities are in Egypt, South Africa, and Nigeria. However, the high-ranking statistics mask the relative low performance of most institutions, especially those established post-94 and those traditionally meant for Black education in the apartheid era. This offers additional evidence that the impact of Apartheid continues to reign supreme within the HE sectors. But it also clearly shows how the standards of the West are still used to measure the quality of HE. In light of this, it can be argued that we cannot continue to measure a transformed HE sector with criteria used before transformation became imperative.

A decolonized operative environment in Higher Education. Decolonized higher education was also defined as higher education that operates within transformed environ-



ments, that is, environments with renamed buildings, removed symbols (e.g., statues with an apartheid or colonial origin), more Black academics, transformed Black university leadership, increased indigenization of the curriculum content, and so forth. Which of these ambitions have been achieved varies across different universities in South Africa. For example, about 18 of the 23 universities are Black VCs. Many key buildings and sports fields have been renamed. Universities have established renaming committees that routinely sit to consider the renaming of university buildings, teaching and learning venues, laboratories, roads, and other public facilities. While we could say that substantial change has taken place in the past 25 years following the abolishment of Apartheid, the most significant feature of the university, which is its curriculum, has largely been left unchanged (Maringe & Osman, 2016). There is insufficient evidence showing that the content of degree programs has substantially changed, despite the change of guard in terms of the university teaching force. Similarly, there is no evidence that the teaching approaches and assessment methodologies have diverged from how they were before 1994. As long as the curriculum remains intact, it can be argued that South African higher education has only been superficially transformed since the demise of Apartheid.

The other dimension of a decolonized Higher Education is its mechanisms of knowledge production. Many senior professors who are highly influential in the decision-making at South African universities are white. There is also no evidence to show that research, both as a process and as a mechanism for creating certain types of outputs, has been adequately transformed. In addition, at many South African universities, the patterns of partnerships for knowledge production have hardly changed. In one university we work at, almost 70% of knowledge partnerships are still with Western universities in Europe and the Americas, especially North America and Canada. While there has been a notable increase in local funding of research at universities, some of the largest sponsors of research (such as the US-based Carnegie Foundation, the Ford Foundation, the Bill and Melinda Gates Foundation and the Spencer Foundation, the German-based DAAD, the European Union, the British-based Leverhulme Trust, the Nuffield Foundation, and the Newton Fund, amongst others) continue to be dominant players in the knowledge production terrain at South African universities. In teacher education, EU funding is a major player in South Africa's knowledge production. The extent to which the agendas of these funding mechanisms are in harmony with local imperatives remains a matter of conjecture and may require analysis in future research.

#### 4.2 The discourse of inclusive education in South Africa

Given the imperatives of establishing an equal, non-segregated and non-sexist society, inclusion has a high-profile presence in teacher education, and more broadly, higher education in South Africa. However, as Sayed, Soudien and Carrim (2003) have noted, the notion of inclusion is mired in intractable debates about its meaning, its priorities and, most importantly, about the efficacy of its associated strategies. Inclusion is thus a slippery concept. It comes with a lot of promise for righting the wrongs of the past, for delivering equal opportunities, especially to previously disadvantaged communities, and for ensuring equal treatment and access to resources among groups with different identities, such as learners with disabilities and learners from disadvantaged and marginalized backgrounds.

The main problem in inclusive practice seems to be the challenge of creating opportunities for marginalized groups without disadvantaging other groups. For example, teaching special groups of learners separately from mainstream groups can be seen as exclusionary. On the other hand, integrating the learners in mainstream teaching and learning formations introduces its own difficulties, including the management of differentiated learning support in a shared environment and the risk of short-changing other learners who need different forms of support.

In South African universities, students from poorer backgrounds, such as those from rural schools, experience multiple challenges. First, the middle-class culture that characterizes many universities is a threat to their process of integration into the university's citizenry. Many come to university without having used a computer or laptop and therefore need time to be socialized into the high-tech learning environment before they can productively engage with their studies. They can very easily be left behind, given the fast pace of curriculum instruction at many universities, although there are often writing centers whose main purpose is to upskill students from disadvantaged backgrounds to a higher level of academic engagement. Evidence suggests that these groups of learners are the most disadvantaged when it comes to the quality of their learning outcomes, non-completion of their degree, exam failure, and repeating or dropping out of learning programs (Badat, 2010). In South Africa, almost 40% of students who start year one do not complete their degree programs. Approximately 80% of these students are from disadvantaged backgrounds characterized by multiple deprivations. For that reason, we can argue that while universities have created more opportunities for disadvantaged learners by promoting greater physical access, the equality of epistemological access remains an issue of great concern. As such, South African universities cannot be said to be providing cognitive justice to all their stu-

dents, especially in terms of access to knowledge, and in terms of pedagogical approaches which recognize issues related to learners' socio-economic backgrounds.

#### 4.3 Issues surrounding the quality of teaching

Elsewhere we have defined quality, not so much in terms of input and output dimensions, but in terms of delivering an educational experience that closes the gaps between historically advantaged and disadvantaged students at our universities (Maringe, Chiramba, Pournara, Ndlovu & Magabane, 2020). Issues of teaching quality in teacher education thus relate to two significant factors:

1. the distribution of good teachers at our universities: the historically white universities tend to have the highest concentration of senior professors, while the new universities have higher concentrations of junior staff. It can thus be argued that students in historically white-only universities experience richer curricular encounters, both in terms of resource availability and the quality of teaching, and the research to which they are exposed. Even though these universities are enrolling larger numbers of Black students from low-income households, there is no escaping the fact that these universities have significant cognitive capital, which the newer and the historically Black universities do not have.
2. inequalities in resource distribution: as noted above, historically white-only universities have larger endowments from traditional sources, which newer universities tend not to have.

The top three richest universities in South Africa, besides UNISA, are all historically white-only institutions, while the three poorest are either new or historically Black universities. The richest universities are also the globally most highly-ranked universities in the country. This pattern replicates global trends, where Harvard (\$41 Billion); Yale (\$30 Billion); Stanford (\$27 Billion) and Princeton (\$26 Billion) perpetually maintain top positions in global university rankings year after year (Moore, 2017). There is thus a close relationship between the quality of teaching and resource availability.

#### 4.4 The role of teacher unions in South Africa

Partly as a mechanism to police the process of transformation from a highly uneven educational terrain deliberately created by Apartheid to one that underpins equality and social justice, teacher unions play a substantial role across all educational sectors,

including in teacher education. As organized labor, teacher unions have diverse functions, such as bargaining for teachers' salaries and conditions of service, and ensuring quality of education and the maintenance of standards in schools (Mafisa, 2017). Because of past injustices, many teacher unions in South Africa tend to be overly protective of their members, even in situations that can be said to compromise the quality of teaching and learning. For example, the unions often come to the defense of teachers, even when their record of absenteeism from school is unacceptable. In South Africa, teacher absenteeism from school is a shockingly prevalent phenomenon (Mothibeli, 2017). Mbiza (2017) has noted that every day in South Africa, 10% of teachers do not pitch for work. According to the 2017 School Realities Report, 10% comprises about 433,320 teachers. Effectively, this means that 135,000 children go untaught daily. The impact this has on learners can be far-reaching: failure, learner absenteeism, learner drop out, poor learner outcomes, the erosion of learning gains, psycho-social issues, and the associated social and economic impacts on society.

#### 4.5 The 4 IR and teacher education

The Fourth Industrial Revolution (4 IR) is a contemporary discourse in teacher education that invites us to contemplate both the affordance and the constraints of a rapidly technologizing world. The single most important idea within this discourse requires that we reflect on the effect of innovations such as automation, robotics, the increasing influence of the internet of things (IoT), 3D technologies, artificial intelligence, and blockchain technologies on the face of workplaces, including classrooms (Schwab, 2016). Two significant impacts of the 4 IR in teacher education include the so-called 21<sup>st</sup> century skills and the higher likelihood that teaching and learning will be more technology-driven, rather than taking place via face-to-face modalities (Mayer, 2020). 21<sup>st</sup> century skills tend to include the following:

- ▶ Technological / digital adaptiveness
- ▶ Ability to evaluate vast amounts of information
- ▶ Criticality and critical thinking
- ▶ Networking and working in and across teams
- ▶ Data capture / harvesting and analytical skills
- ▶ Technological / digital literacy and competences
- ▶ Complex problem-solving
- ▶ Emotional intelligence
- ▶ Negotiation
- ▶ Cognitive flexibility

Indeed, teachers of the future will need to learn some or all these skills. The challenges we face at our differentiated and differently endowed universities include the extent to which all students will have access to similar levels of technologically and digitally supportive teaching and learning environments; considerations surrounding developmental priorities in specific contextual settings, i.e., the question whether, in the context of the developing world, our priorities should be poverty alleviation and the dismantling of inequalities, or following the developmental trajectories of the more developed world; and whether the rationale of the 4 IR remains steeped in colonial intentions of exerting dominance over the poorer nations in order to continue extracting raw materials and cheap labor from them (Rodney, 1972). In the final analysis, technology should not dictate our developmental priorities. It is the developmental priorities that should dictate the technologies we embrace.

#### 4.6 Disruptions and teacher education in South Africa

The COVID-19 pandemic has led to school closures in over 190 countries across the world. Consequently, more than 90% of school-going learners have experienced disruptions in schooling (UNESCO, 2020).

Literature searches on the causes of school disruption / closures yielded three different clusters: disease, natural disasters, and long summer breaks, particularly in the Northern Hemisphere. We focused mainly on the first two, although the impact of summer learning loss in the US has been used to model potential learning loss due to COVID-19 (Soland et al., 2020). To concentrate on research that was likely to pay attention to low-income contexts similar in poverty levels to those in South Africa, we limited ourselves to studies in the developing world, such as Indonesia (Rush, 2018), Nepal (Ezaki, 2018; Mu et al., 2016), Pakistan (Andrabi, Daniels & Das, 2020), Philippines (Cummiskey et al., 2020), Sierra Leone (Powers & Azzi-Huck, 2016; Rasul, Smurra & Bandiera, 2020), and Rwanda (Thomas, 2010). We did, however, consider reports on the 1916 polio pandemic in the US (Meyers & Thomasson, 2020) and on Hurricane Katrina (Hill, 2020), since they were used in predicting the impact of COVID-19 in various ways.

It is worth mentioning that there is little research published in peer-reviewed academic journals related to the focus of the question pursued here. Most of the research appears in reports, blogs and other web-based publications, and is reported by international aid agencies (e.g., UNESCO, USAID and World Bank) and non-profits (e.g., UKFIED and RTI). Not surprisingly, this research is mostly quantitative and based on relatively large samples. It is also not surprising that the authors and publi-

shers are generally based in the developed world and/or associated with institutions in the global North, which receive funding from the above-mentioned (and other) aid agencies. The research is unanimous: disasters, whether stemming from natural disasters or disease, impact the poor most severely, and this has knock-on effects that extend to schooling (World Bank, 2020).

When it comes to the specific effects on schooling, the research findings are not always unanimous, being influenced by social and political contexts, government responses, and the nature of the disruption. However, there is agreement that extended school disruptions lead to learning loss and negative psycho-social effects for *all* learners, and that this effect, unsurprisingly, is greatest for learners from low-income families (World Bank, 2020). This may be related to the general lack of access that low-income families have to resources needed to recover from all aspects of a crisis. Furthermore, education is a lower priority in a household that is fighting for survival. There may be less home-based support than in households of a higher socio-economic status due to the parents' lower level of education, as well as a lack of time and physical space for learning at home. While schools are closed, they may have little, if any, access to “replacement pedagogies” (our term), such as radio or TV broadcasts and other forms of online learning (Kerr & Baxter, 2020).

A key distinction needs to be made between the impact of disruptions on *school attendance* and the impact on learning. Concerning school attendance, some studies report that attendance typically returns to pre-crisis levels over time (e.g., Ezaki, 2018; Powers & Azzi-Huck, 2016). However, others have explored various causes of dropout, finding that girls generally experience greater negative effects from disruptions. These include missing or dropping out of school because of pregnancy or mothering responsibilities, as well as a lack of family investment in their education. By contrast, families tend to invest more in the education of male children. However, in contexts such as farming, it is expected that males can make a greater contribution to the household income. Therefore, they may miss school and/or drop out following extended disruptions (Mu et al., 2016).

In general, the disruptions have a greater impact on secondary schools than on primary schools (Rush, 2018). There are various reasons for this difference. One reason is that learners typically live closer to their primary school, which makes it easier to attend school, especially after natural disasters, when access to schools further away may not be possible. Lower attendance by older learners may result from being required to work in order to support the household income (Mu et al., 2016).

When it comes to learning, the research is unanimous that the learning loss is greater for younger children and that these effects accumulate over time, with the consequen-

ce that they may be unable to learn new content at later stages because of the earlier gaps (World Bank, 2020). On the other hand, younger learners will have more time in school, during which they can benefit from intervention programs.

With respect to subjects, it should be noted that the research typically focuses on performance in literacy/language/reading and numeracy/math. The impact on performance in numeracy/math is greater, which is not surprising, given the hierarchical nature of mathematics and the importance of having a solid foundation on which to build new knowledge. Various models have been proposed to predict the impact of COVID-19 on learning loss. The data are drawn mainly from the developed world, where extensive sets of (historical) educational data exist based on national assessments (e.g. Soland et al., 2020) and/or international assessments (e.g. PISA). However, there are also instances of models using data from the less developed world, such as the Philippines (Cummiskey et al., 2020).

## 5 Conclusion

Almost 26 years after the abolishment of Apartheid in South Africa, the structural edifices of inequality continue to manifest themselves in all sectors of life, including in higher education and in teacher education. In this chapter we have argued that much of the transformation in post-apartheid South Africa, despite the good intentions at the core of our democratic policies, have been largely cosmetic or superficial. The color of the academy, and its physical composition and structures, have changed and continue to do so. This is firmly supported by laws and policies based on the country's democratic and non-discriminatory constitution. However, inside this outer shell, the system continues to show evidence of limited transformation, exhibiting a stubborn resistance to change, which we explained in this chapter as a form of coloniality in higher education.

We have argued that there is a need to move towards unpacking the curriculum from the entry foundation phase to the upper end of the spectrum. We are not oblivious to the magnitude of the task. However, the chronological injuries sustained from the epistemological violence experienced over the years are hidden in the knowledge we acquire and the way we acquire it. We warn against addressing this issue superficially and symbolically only, and call for the development of a framework with core values that prioritize the African identity. We also need to discover explicit and credible ways of knowing, of disseminating new knowledge, and of engaging with the wider world. Furthermore, we need to realize that there will be elements from the past we wish to

preserve, and that, as painful as it may be, we must keep guard against the persistent coloniality that characterizes our teacher education sectors.

The chapter began with a conceptual discussion of the issues surrounding the continued coloniality of teacher education in South Africa. We examined four central notions: colonialism, decolonization, coloniality and decoloniality. We then provided a brief historical discussion to show the origin of the current status quo in South Africa's teacher education. This was followed by an examination of the post-94 changes that took place in teacher education. The chapter ended with a brief discussion of six discourses: decolonization, inclusive education, teacher quality, the role of teacher unions, the impact of the 4 IR, and, finally, the impact of disruptions in teacher education in South Africa. In the discussion, several critical research questions were raised, which could give new impetus to exploring the evolving status of teacher education in South Africa. The phase we enter now will be characterized by difficult steps towards dismantling the stranglehold of coloniality in higher education and teacher education.

## Literature

- Andrabi, T., Daniels, B., & Das, J. (2020). *Human capital accumulation and disasters: Evidence from the Pakistan earthquake of 2005*. OSF. <http://doi.org/10.17605/OSF.IO/3QG98>.
- Badat, S. (2010). *The challenges of transformation in higher education and training institutions in South Africa*. Research paper commissioned by the Development Bank of Southern Africa DBSA.
- Bush, T., Bell, L., & Middlewood, D. (2019). *The principles of educational leadership and management*, (2<sup>nd</sup> ed.) SAGE.
- Breene, K. (2016). What is the future of the internet? (Formative content) *World Economic Forum*. <https://www.weforum.org/agenda/2016/01/what-is-the-future-of-the-internet/> [19.05.2021].
- Chachage, C. S., & Chachage, S. L. (2004). Nyerere: Nationalism and post-colonial developmentalism. *African Sociological Review*, 8(2), 158–179.
- Chisholm, L. (2020). *Landscapes of teacher education in South African history*. Oxford University Press.
- Cross, M. (1986). A historical review of education in South Africa: Towards an assessment. *Comparative Education*, 22(3), 185–200. <http://www.jstor.org/stable/3099112>.
- Cummiskey, K., Adams, B., Pleuss, J., Turner, D., Clark, N., & Watts, K. (2020). Causal inference in introductory statistics courses. *Journal of Statistics Education*, 28(1), 2–8.
- Darling-Hammond, L. (2007). Race, inequality and educational accountability: The irony of 'no child left behind'. *Race Ethnicity and Education*, 10(3), 245–260.
- Darwin, H. (2017). Doing gender beyond the binary: A virtual ethnography. *Symbolic Interaction*, 40(3), 317–334.
- Davids, N., & Waghid, Y. (2020). Leading article tracking five years of teacher education enrolment at a South African university: Implications for teacher education. *South African Journal of Higher Education*, 34, (1–16). [http://www.scielo.org.za/scielo.php?script=sci\\_arttext&pid=S1753-59132020000200001&nrm=iso](http://www.scielo.org.za/scielo.php?script=sci_arttext&pid=S1753-59132020000200001&nrm=iso).
- DHET (Department of Higher Education and Training). (2015). National Qualifications Framework Act, 2008 (Act No. 67 of 2008). Revised Policy on the Minimum Requirements for Teacher Education Qualifications. Government Gazette Vol. 596, No. 38487. Pretoria: Department of Higher Education and Training.



- Ezaki, N. (2018). Impact of the 2015 Nepal earthquakes on children's schooling: Focusing on individual children's enrolment flow. *Education 3-13*, 46(7), 867-878.
- Fanon, F. (1965). *This is the voice of Algeria. A Dying Colonialism*. New York: Monthly Review, 69-98.
- Hill, P. (2020). *What post-Katrina New Orleans can teach schools about addressing COVID learning losses*. <https://crpe.org/what-post-katrina-new-orleans-can-teach-schools-about-addressing-covid-learning-losses/> [24.09.2020].
- Hoyos, A., & Angel-Urdinola, D. F. (2017). *Assessing the role of international organisations in the development of the social enterprise sector*. Policy Research Working Paper No. 8006, World Bank, Washington DC.
- Kerr, K., & Baxter, M. (2020). *The impact of COVID-19 on secondary education in Africa: Amplifying challenges and opening new opportunities*. AllAfrica <https://allafrica.com/stories/202008110663.html>.
- Mafisa, L. J. (2017). The role of teacher unions in education with specific reference to South Africa. *Gender and Behaviour*, 15(4), 10553-10566.
- Maldonado-Torres, N. (2011). Thinking through the decolonial turn: Post-continental interventions in theory, philosophy, and critique – An introduction. *Transmodernity: Journal of Peripheral Cultural Production of the Luso-Hispanic World*, 1(2).
- Maldonado-Torres, N. (2007). On the colonality of being, contribution to the development of a concept. *Cultural Studies*, 21(2-3).
- Maravanyika, O. E. (1990). Implementing educational policies in Zimbabwe: World Bank discussion. *Africa technical department series*, Paper No. 91.
- Maringe, F. Chiramba, O. Pournara, C. Ndlovu, N., & Magabane, A. (2020). *The impact of Covid-19 in low-income households in South Africa*. Unpublished report for the ZENEX Foundation Learning Brief.
- Mayer, S. E., Kalil, A., Oreopoulos, P., & Gallegos, S. (2019). Using behavioral insights to increase parental engagement: The parents and children together intervention. *Journal of Human Resources*, 54(4), 900-925.
- Mazrui, A. A. (2004). Kwame Nkrumah. *Debating the African condition: Governance and leadership*. Africa World Press.
- Meyers, K., & Thomasson, M. (2020). *Paralyzed by panic: Measuring the effect of school closures during the 1916 polio pandemic on educational attainment*. NBER Working Paper Series, Working Paper 23890.
- Mbembe, A. (2001). *On the postcolony* (vol. 41). University of California Press.
- Mbiza, E. (2017). *Constitutionalization of children's rights: A comparative analysis of post-ratification national constitutions of South Africa and Zimbabwe*. Université de Genève-Centre for Children's Rights Studies.
- Moletsane, R. (2012). Repositioning educational research on rurality and rural education in South Africa: Beyond deficit paradigms. *Perspectives in Education*, 30(1), 1-8.
- Moore, R. C. (2017). *Childhood's domain: Play and place in child development* (vol. 6). Routledge.
- Mothibeli, T. R. (2017). *The causes and effects of uncontrolled teacher absenteeism in selected public primary schools in Mangaung metro municipality (Bloemfontein)* (Doctoral dissertation, Central University of Technology, Free State).
- Mu, R., Brewer, L., Crowder, L., Lee, M., Mikayilov, E., Nepal, S., . . . Wendelbo, M. (2016). *The impact of natural disasters on child education outcomes: Evidence from Nepal*. Texas A & M University.
- Mugumbate, J. R., & Chereni, A. (2020). Now, the theory of Ubuntu has its space in social work. *African Journal of Social Work*, 10(1).
- Ndlovu-Gatsheni, S. J. (2020). The cognitive empire, politics of knowledge and African intellectual productions: Reflections on struggles for epistemic freedom and resurgence of decolonization in the twenty-first century. *Third World Quarterly*, 1-20.
- Power, S., & Azzi-Huck, K. (2016). The impact of Ebola on education in Sierra Leone. Education for Global Development. <https://blogs.worldbank.org/education/impact-ebola-education-sierra-leone> [22.09.2022].
- Quijano, A. (1998). The colonial nature of power and Latin America's cultural experience. In *Social Knowledge: Heritage, Challenges, Perspectives, International Sociological Association, Pre-Congress Volumes*, 4(9), 113-122.
- Rasul, I., Smurra, A., & Bandiera, O. (2020). *Lessons from Sierra Leone's Ebola pandemic on the impact of school closures on girls*. The Conversation. <https://theconversation.com/lessons-from-sierra-leones-ebola-pandemic-on-the-impact-of-school-closures-on-girls-137837> [24.11.2020].
- Rodney, W. (1972). *How Europe undeveloped Africa*. Bogle-L'ouverture Publications.
- Rush, J. V. (2018). The impact of natural disasters on education in Indonesia. *Economics of Disasters and Climate Change*, 2(2), 137-158. <https://doi.org/10.1007/s41885-017-0022-1>.

- Sayed, Y., Soudien, C., & Carrim, N. (2003). Discourses of exclusion and inclusion in the South: Limits and possibilities. *Journal of Educational Change*, 4(3), 231–248.
- Schwab, K. (Ed.) (2016). *The global competitiveness report 2016-2017*. World Economic Forum.
- Soland, J., Kufeld, M., Tarasawa, B., Johnson, A., Ruzek, E., & Liu, J. (2020). The impact of COVID-19 on student achievement and what it may mean for educators. <https://www.brookings.edu/blog/brown-center-chalkboard/2020/05/27/the-impact-of-covid-19-on-student-achievement-and-what-it-may-mean-for-educators/> [20.05.2020].
- UNESCO. (2020). *Education: From disruption to recovery*. <https://en.unesco.org/covid19/educationresponse> [24.09.2020].
- Van der Berg, and Hofmeyr, H. (2018). *An incomplete transition: Overcoming the legacy of exclusion in South Africa, A World Bank Systematic country diagnostic*. World Bank Group.
- World Bank. (2020). *The COVID-19 pandemic: Shocks to education and policy responses*. <http://hdl.handle.net/10986/33696> [20.05.2020].



## Chapter 2

# Teacher Education in Germany: Educational Structures, Historical Developments and Academic Challenges

Elisabeth Hofmann and Thorsten Bohl

*This chapter begins with an overview of historical developments in Germany's teacher education. It explains the changing characteristics of the teaching profession with a focus on teacher education for the German Gymnasium, a school type leading directly to A-Levels. The requirements and structures of teacher education in Germany today are introduced, including current models and patterns, teachers' standards and teacher certification, induction and professional development structures.*

*The second part focuses on emerging challenges faced by educational governance, educational research, and educational practice today. These include teacher shortage and recruitment, inclusion and educational equality, changing school structures, professionalization of teachers, and digitalization in education. The chapter closes by summarizing the challenges and future directions of teacher education, showing how teacher education can react to and integrate local and global challenges at schools and universities.*

### 1 Introduction

Schools are places in which education and Bildung<sup>1</sup>, instruction and development, and the qualification of society's future generations take place. Schooling influences

---

<sup>1</sup> The German term 'Bildung' is rooted in German idealistic thinking. It defines education as self-development, self-actualization and critical reflection, as opposed to education that focuses on the adaptation of existing knowledge, pre-established competences, or societal expectations (Biesta, 2002; Koller, 2017).

not only individual life courses as well as personal and career opportunities, but also societal cohesion and the overcoming of future societal and global challenges. Thus, modern educational systems serve to “constitute basic cultures and mindsets, identity and the communicative abilities of its members – and to establish those in future generations in order to protect cultural coherence and the cohesion of the societal community” (Fend, 2008, p. 49). These functions of schooling are undisputed. By establishing public schools, the government moves schooling away from other subsystems such as family, and establishes public schooling as a publicly controlled subsystem that specializes in a certain type of long-term, systematic and cumulative learning (Baumert, 2006). This procedure emphasizes the aim as well as the opportunity to make societal participation independent of social backgrounds, to generalize participation and to make it accessible for all (Tenorth, 1994). However, as history shows, the German school system is susceptible to political controversies and ideological misuse.

Governments are aware of the importance and impact of school and education. In Germany, up to 150 billion euros (4.3% of the GDP) were used for the educational sector in 2019. In consequence, the government holds authority over aims, processes and contents, setting the standards for the use of educational contents and structures. Teachers carry the responsibility for reaching educational goals in collaboration with their students. Describing teachers as “deputies of societal modernization processes” (Sandfuchs, 2004, p. 15) indicates the strong societal importance of teachers. Empirical research confirms the importance of the individual teacher for successful learning processes: “It depends on the teacher” (Lipowsky, 2006). The governments’ fundamental concern is that upcoming generations will be best prepared to face societal challenges if educated by highly qualified and well-trained teachers. This is why the government claims to define aims, structures, processes, and contents in academic teacher education. It is also reflected in the school-based phase of initial teacher training: teaching students have to pass examinations, which are regulated by the educational ministry, before finally entering the teaching profession. School curricula and educational frameworks are also defined by educational ministries. A recent example of policy-based reform is the Quality Initiative for Teacher Education, which began in 2014. Here, the provision of governmental funding for the teaching degree programs B.Ed and M.Ed. is closely monitored, and content-related decisions are defined by governmental institutions, or negotiated between government and higher education.

This chapter aims to introduce basic structures of teacher education in Germany. Applications and examples are included with reference to the approach of the Tü-

bingen School of Education. As the Tübingen School of Education provides teacher education for the Gymnasium, the German high school, this chapter has a focus on Gymnasium teacher education.

## 2 The German basic education system

Traditionally, the German educational system has been three-tiered, with students being separated into three different school types after primary school, according to their achievements (Figure 1; see Sandfuchs, 2004; Terhart, 2016). The development of schools today aims at a two-tiered system, but in many states, including Baden-Württemberg, there are more school types remaining.

Students in Germany visit primary school for four years before enrolling in secondary education. The secondary school types Gymnasium, Realschule and Hauptschule have shaped the German educational landscape for several centuries, though the names of the school types have varied through history.

Gymnasium is the German equivalent of high school leading to the Abitur, the German school-leaving certificate, which is comparable to Advanced Levels (A-Levels). Gymnasium education begins in year 5, leading directly to the Abitur in year 12. It is characterized by expecting the highest academic standard from its students.

Realschule is the German equivalent of middle school. Education at Realschule begins in year 5 leading up to year 10, with an examination comparable to O Levels. Realschule prepares students to enter vocational schools and the labor market at approximately 16 years of age. Hauptschule is another type of middle school, beginning in year 5 and leading up to year 9. Hauptschule used to be a school for students demonstrating lower academic results than requested at Realschule. Its graduates were also prepared to enter the labor market or vocational schools at the age of 15 or 16.

Since 2010, the federal state of Baden-Württemberg reformed its educational system, aiming for a more inclusive type of middle school. This new type is called the Gemeinschaftsschule (community school). It offers curricula for all three aforementioned levels and leads to different O Level options. Some schools of this type even offer a path towards the Abitur after year 13.

Special needs education in Germany allows learners to enroll at specialized schools or to receive inclusive education through support structures within a Gymnasium or Gemeinschaftsschule. Inclusive education was introduced during the last decade.

Figure 1 shows the German educational landscape in 2019.

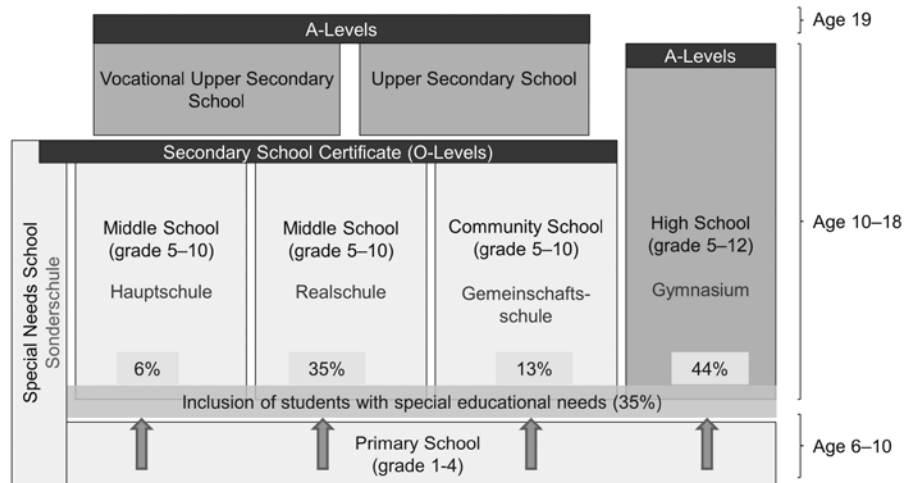

Figure 1 School system in the federal state of Baden-Württemberg in 2019

The historically three-tiered school system which allocated and still allocates students in Germany at the early age of ten to different educational institutions, contributes to and reproduces social divisions in Germany's society until today. The allocation to school types often correlated with parental social backgrounds, this influence still remains until today to a smaller degree. (Büchler, 2016). The early allocation to a certain school type was also criticized as having stigmatizing effects on learners and their families. While for decades, allocation to secondary school types was based on academic grades, it has been based on parental choice since 2010 serving as an important step towards educational equality.

Formally, the present school system in Germany is highly differentiated, with 16 federal states (Bundesländer) creating their own educational landscapes. One shared element is the school type Gymnasium, which remains in all federal states, while other secondary school types vary. Current controversies include the question of whether other secondary school types should establish a curriculum leading to the Abitur and offer examinations for it.

### 3 Historical developments in teacher education in Germany

The school system and the development of teacher education are closely connected. Looking at historical developments, the Gymnasium teacher served as a teacher for all school subjects since the end of the 18<sup>th</sup> century. The profession was created to strengthen the division between the clergy and education. The high school teacher was a

classical philologist, serving general human education and especially *Bildung*, according to German new-humanistic ideals.

Since 1834, the Abitur was required for enrollment at universities in the region then called Prussia. A future high school teacher had to study the high school subjects and complete a governmentally controlled exam on subject knowledge. High school curricula developed a broader range of subjects, in addition to the classical philologies, such as foreign languages and natural sciences. A high school teacher was required to be an academic with profound content knowledge. The Gymnasium became an established form of exclusive schooling for a small male part of the population. The two characteristic phases of teacher education gradually became more differentiated. High school teachers had to study two subjects during the academic studies phase. From 1917 to 2017, the second, school-based phase was completed with the second state examination. Teacher education for other school types, especially the general community teacher (primary and lower secondary teacher covering grades 1–9), used to follow the model of high school teacher education. However, several differences remained due to the length of studies, salary, reputation and self-image. The education of general community teachers developed gradually during the 19<sup>th</sup> century through the establishment of teacher seminars and of compulsory education for anyone living in rural areas.

A further important step was the requirement of the Abitur for future community teachers since 1927 in Prussia. All teaching applicants had to complete academic studies (with different durations), followed by initial teacher training.

In the second half of the 20<sup>th</sup> century, teacher education became more academic for teachers in lower secondary and primary school. High school teaching degree programs, on the other hand, included more pedagogical competences. Theoretical models of learning and achievement became more nuanced, and their development has led to a long-lasting impact on the educational system. Theoretical educational ideals assigned to different school types in Germany were questioned, leading to a new and critical academic discussion about all school types and age groups since the 1970s (see v. Ackeren, Klemm & Kühn, 2015). A new concept of the teaching profession evolved, and is best described by Terhart (2016, p. 27): a teacher is “an academically trained expert for teaching and learning: with profound knowledge on subject and methods, supporting his/her students as an educational coach, a competent counsellor for parents, cooperation with colleagues, open for professional development and innovation”. The Bologna Process at the beginning of the 21<sup>st</sup> century shaped the organizational aspects of teaching degree programs: the former 5-year teaching degree programs were replaced by a 3-year bachelor's and a 2-year master's degree. From then on, ex-



aminations were led by academic representatives instead of governmental representatives. The polyvalent degrees and the bachelor-master structure were introduced to advance mobility between universities in Europe and worldwide. The new cumulative study structure allowed graded study results from each year to be factored in, instead of grading only the final examinations after year 5.

#### 4 Current state of teacher education

The current situation of teacher education cannot be easily described. Due to the autonomy of the sixteen federal states in educational matters, the structure of teacher education is defined individually by each state. The German high school, *Gymnasium*, has remained as an institution in all 16 federal states, while the number of other school types varies greatly. Between two and five different school types exist additionally, depending on the federal educational policy. In order to compare the different structures across the federal states of Germany, the Conference of the Ministers of Education (KMK) defines six types of teachers.

Teaching degree type	Description
Type 1	Primary teachers
Type 2	Teachers for primary school and all or some lower secondary schools
Type 3	Lower secondary teachers for all or some lower secondary schools
Type 4	Teachers for high schools
Type 5	Teachers for vocational schools
Type 6	Special needs teachers

*Table 1 Teachers according to school types (Kultusministerkonferenz, 2019)*

On the institutional level, teacher education takes place at universities throughout Germany. Baden-Württemberg is a special case: Universities of Education co-exist with General Universities. The former offer teaching degree types 1, 2, 3 and 6, while the latter offer teaching degree types 4 and 5.

At the University of Tübingen, there are 27,500 students (winter term 2019/2020), of which 3,800 study teaching. This constitutes 18% of the students, underlining that teacher education is a large and important field in Tübingen. It offers more than 25 teachable subjects, ranging from established subjects such as Math and English, to Chinese and Astronomy. Less common subjects are highly valued as they contribute to the development of individual school profiles and allow students more

options for choosing subjects according to their individual interests and goals. The following graph shows the academic subjects with the highest percentage of teaching students:

Subject	Number of teaching degree students	Percentage of teaching degree students
Mathematics	431	59,45 %
German	940	51,65 %
English	1516	61,58 %
Physical Education	407	58,34 %
Islamic Theology	103	44,02 %

*Table 2 Percentage of teacher education students in selected subjects (at the University of Tübingen in 2019/20)*

Table 2 illustrates that Tübingen's large and traditional subjects, as well as some of its younger subjects, are chosen to a large degree by teaching degree students. In Baden-Württemberg, the University of Tübingen hosts the highest number of students studying teaching degree type 4.

Study programs in all federal states and for all teachers consist of four clearly defined areas: content knowledge (CK), pedagogical content knowledge (PCK), educational sciences / pedagogical knowledge (PK), and school internships.

The multiple school types, however, created several differentiations: the key characteristic in the education of Gymnasium teachers is a higher proportion of subject-specific content knowledge (CK) and a smaller proportion of pedagogical content knowledge (PCK) and pedagogical knowledge (PK).

New topics have been added during the last 10 years. They include: diversity and inclusion, digital media education, subject-specific content knowledge in all teachable subjects, global educational perspectives, as well as research-based mentoring during school internships and beyond.

During the last 20 years, the discussion and creation of research-based national standards in teacher education has begun. One significant result of this is that the KMK's 2004 'Standards for Teacher Education: Educational Sciences' were implemented in all federal states (Länder). They are points of reference for the education of future teachers in the academic phase as well as in the school-based phase. They are also a guideline for creating new structures in teacher education. By applying these standards, different teaching degree programs in the 16 federal states are made more comparable in terms of their minimum requirements and levels (Terhart, 2007). The standards fueled discourses in teacher education research regarding standards, minimum

requirements, measurability and accountability, the relation of theory and empirical research, and professionalization theory. They were also criticized for leading to simplistic perspectives on teachers' abilities and for being tools of strong regulation and control. Still, the standards are formulated as very broad competences, leaving maximum openness in how to reach them. As Terhart argues, the existing aims and expectations of this public profession were merely put into official words (Terhart, 2007, p. 9). Standards for pedagogical content knowledge were also created by the KMK in 2019. The discussion of the PCK standards is highly dependent on their specific realization at the different universities and thus mainly continues within universities. However, the approaches for standardization cannot change the fact that 16 different educational structures are implemented in Germany's federal states due to their autonomy in cultural and educational matters. This leads to more questions regarding teacher education: should it take place according to age and educational stages, or according to school types? Which classes are the same for all students? Do the changes in school types correspond to differences in teachers' payment? These questions are again addressed differently in each federal state.

#### 4.1 Bachelor's and master's structures for teaching degree programs

In most German federal states, former so-called state examination degrees for teachers have transformed into consecutive bachelor's and master's degrees during the last decade. Many federal states, such as Baden-Württemberg, switched to a bachelor's and master's structure, while some, like Saxony and Hesse, maintained the former state examination structure. But even within the new structure, variations remain within Germany, especially in the bachelor's programs: a Bachelor of Education serves as basis for the Master of Education and focuses on the teaching profession from the beginning; a polyvalent Bachelor (of Arts or Sciences) can serve as foundation for different master's programs and allows more flexible career choices. On the master's level, the Master of Education, which has a clear focus on the teaching profession, is the prerequisite for teaching at public schools. The study programs differ in length as well as in the number and allocation of ECTS points (points within the European Credit Transfer System). The duration of studies differs, especially for teaching degrees of type 1 (primary teaching), which varies in length and salary in some federal states. The existing differences between the federal states challenge the overall comparability, as well as the transfer between universities, even though the KMK works on the basis of the mutual acceptance of degrees. The situation is criticized in multiple ways and typically described as patchwork (Keuffer, 2010, p. 51).

#### 4.2 Academic structures of teacher education at the University of Tübingen

Studying teaching in Tübingen means studying to become a high school teacher (teaching degree type 4). A small number of students studies to become a vocational teacher (teaching degree type 5). The structure of the study program is defined by Baden-Württemberg's educational framework, which sets standards for duration, distribution of credits, and curricula. Tübingen chose to offer a Bachelor of Education instead of a polyvalent Bachelor (of Arts or Sciences), requiring students to focus on the teaching profession from the very beginning. Figure 2 illustrates the study program for high school teachers (teaching degree type 4) which is offered at the University of Tübingen.

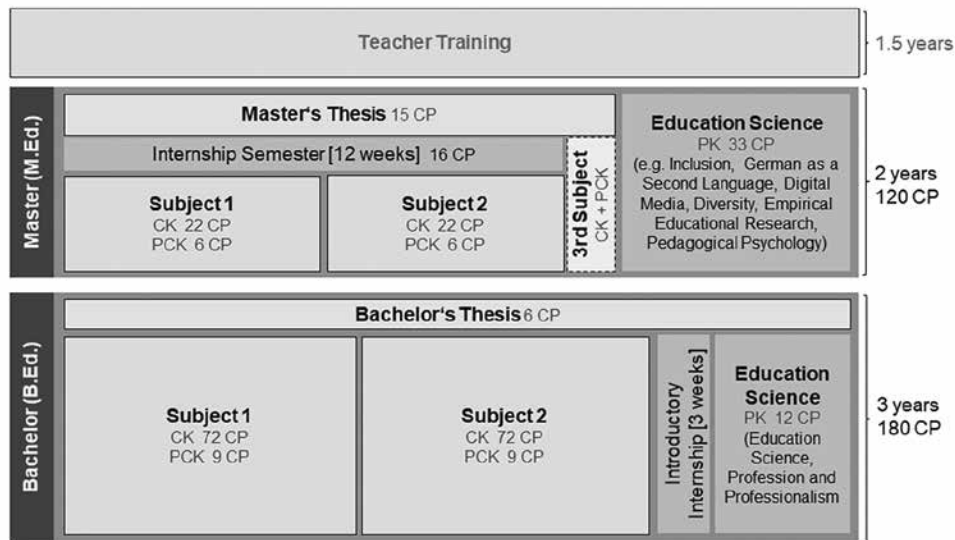

Figure 2 Structure of the consecutive teaching degree program at the University of Tübingen

Like all national teaching degree programs, the program consists of four fields: content knowledge (CK), pedagogical content knowledge (PCK), educational sciences (PK), and school internships. With the introduction of the bachelor's and master's system, the PCK and PK parts were strengthened, while the CK parts were reduced. The main internship (12 weeks) is offered during the Master of Education, which is rather late. Students study two subjects in addition to educational sciences, and a third subject may be chosen voluntarily to improve career opportunities later on.

## 5 Teacher certification, induction and professional development

### 5.1 Teacher certification

To become licensed teachers, students must complete two certificates. The academic studies are completed with a Master of Education. Here, the students develop research-based knowledge in two school subjects as well as in educational science. During their school internships, they gain insight and develop their ability to reflect. The school-based phase is completed with the second state examination for teaching. Graduates from the M.Ed. enroll in 1.5 years of supervised teacher training and must pass teaching practice examinations, where the student teacher's teaching is examined in class, as well as oral examinations.

### 5.2 Induction

The induction phase consists of 1.5 years of supervised, school-based teacher training, as well as the subsequent first years as an official teacher. „During teacher training, the trainees enlarge and deepen their PK and PCK knowledge, which they acquired during their first phase of education, enabling them to fulfil the educational and developmental aims at high schools successfully and responsibly” (Cramer, Johannmeyer & Drahm, 2019a). During the first years in the job, further examinations must be passed in order to receive full status as a lifelong civil servant.

### 5.3 Professional development

The teaching profession in Germany is shaped by a two-phase education (academic and school-based), followed by „decade-long continuous professional practice“ (Drahm & Huber, 2019). Teachers are expected to react professionally in various educational situations and to respond to societal changes, which requires a reflective attitude combined with continuous development of knowledge and competences. Professional development should therefore be an important part of teacher professionalism. However, professional development regulations for teachers in Baden-Württemberg are vague, and participation is rarely assessed by principals or educational authorities. The professional development of teachers is a field that is only partly structured and hardly empirically analyzed, according to Cramer et al. (2019a). Professional development courses should be clearly integrated in teachers' schedules and the quality of these courses should be assessed regularly (Cramer et al., 2019a). The Tübingen School of

Education supports several empirical research projects on teacher professional development and offers research-based classes covering new topics in teacher education.

## 6 Emerging discourses in teacher education

The development and structure of teacher education is a strongly discussed topic within the academic community as well as in educational policy discourse. The omnipresent slogan “teacher education must be improved” reveals the demand for teachers to initiate changes in society and education. Current topics and discourses cover societal challenges such as digitalization and globalization, practical educational problems such as teacher shortage and changes in school types, academic discourses such as professionalization theories, and developments in the underlying values of educational settings, such as implementing inclusion and achieving educational equality. The following section introduces essential current discourses of educational governance, educational research, and educational practice.

### 6.1 Teacher shortage and teaching licenses for other professionals

Increased migration and growing birth rates have led to higher enrolment rates at schools in Germany. Additionally, new school concepts such as longer school days and inclusive education have increased the need for teachers. The KMK expects an additional rate of 60.000 teachers during the next five years, while experts suggest even higher numbers (Klemm, 2019). To cover the teacher shortage, all federal states have established routes for other professionals to enter the teaching profession and receive different types of teaching licenses. The approach has been criticized for deprofessionalizing teaching in times of shortage; however, there are few alternatives. The urgent teacher shortage in all school types except high school is rooted in the historically differing study programs, salary, reputation, and self-image of the teaching profession. In socio-economically challenging regions, as well as in rural regions, the teacher shortage becomes even more urgent.

### 6.2 Inclusion as a challenge in schools and teacher education

Educational systems and teacher education work towards inclusive education, turning institutional, national and international guidelines of inclusion into reality. Inclusive schooling includes accepting and respecting diversity, while reducing disci-

minatory attitudes, contents, and educational structures (Prengel, 1993). The Index for Inclusion serves as a pragmatic reference for inclusion (Booth & Ainscow, 2017), while the term “inclusion” itself can be understood in multiple ways.

In the following, three approaches of inclusion are introduced, from narrower concepts to wider ones (Lindmeier & Lütje-Klose, 2015):

- ▶ Inclusion in a narrow sense, as reducing barriers for persons with handicaps.
- ▶ Inclusion in a wider sense, as „education for all“, focusing on differences between learners.
- ▶ Focusing on all learners, but especially focusing on vulnerable groups. “Education for all, and especially for some.”

Turning a traditionally divided school system into an inclusive one creates several challenges. Pathways to the Abitur are becoming more flexible and variable. Gemeinschaftsschulen (community schools) create a direct path towards the Abitur (Gemeinschaftsschule with an upper secondary option). Vocational training develops a higher reputation and can be combined with other educational pathways. This makes it possible to accept advanced craftsman titles as equivalent to Abitur, allowing some applicants to enroll into study programs within the thematic field of their respective craftsman training.

Learners with diagnosed special educational needs in Germany choose between inclusive education and special needs schools. This allows learners who choose inclusive education to enter a direct path towards the Abitur while receiving specialized support. At German schools and in German society, the perception of inclusion is gradually shifting from narrow concepts to wider ones. The different solutions in the educational system again reflect the situation in teacher education: on the one hand, a specific teaching degree for special needs is offered (type 6); on the other hand, topics of inclusion have become a stable element in all teaching degree programs.

The Tübingen School of Education has committed to including topics on diversity in their teaching degree programs: since the beginnings of the Quality Initiative Teacher Education in 2015, a new chair has been established for the field diversity, inclusion and exclusion at the University of Tübingen. The chair offers a compulsory module – „Fundamentals of Inclusion, Diversity and Heterogeneity” – within the Master of Education, ensuring that all teaching degree graduates have worked on fundamental aspects of inclusion during their studies. Each module serves as thematic unit, consisting of one or several classes. A completed module indicates that the student has achieved the learning goals of the respective unit. Topics range from language-sensi-

tive teaching, migrancy, and class, to gender, religion, and theories of inclusion and exclusion. Additional qualification modules are offered for students who wish to deepen their knowledge in areas such as multilingualism or anti-racist educational work.

Including a new topic in teacher education led to changes on the curricular level: carefully edited ECTS packages were adapted, replacing established topics with more recent ones. This resulted in the reduction of some elective modules or in less flexible study plans – changes which challenged students and lecturers alike.

### 6.3 Teacher professionalization theories

In Germany, the academic discourse on teacher professionalization is dominated by the following three approaches (Hermann & König, 2016).

- ▶ Professional competence theory: the term „competence“ shapes the discourse on international comparative educational research, the most common study being PISA (Program for International Student Assessment). Competences are defined as skills for solving problems at work and at home. Competences can be taught, learned and assessed via specific test tasks.
- ▶ Helsper's approach, structural theory (2011), emphasizes that teacher professionalism consists of specific structural, logical elements. These elements must be reconstructed in order to be analyzed reflectively. The approach focuses on basic structures between learners and teachers, and less on subject-specific questions. Helsper describes several antinomies, such as distance versus closeness and trust versus control, which shape the characteristics of teaching situations.
- ▶ Professional biographical theory focuses on the individual personal and professional development of a teacher. Becoming a professional teacher is described as an individual professionalization process aiming at developing one's own professional identity.

The three approaches compete with and complement each other at the same time. Cramer et al. suggest developing a metatheoretical perspective, allowing reflection on and integration of several approaches (Cramer et al., 2019b). Universities and researchers in German-speaking countries differ widely in their teaching and application of the above-mentioned approaches, revealing different perspectives on the essence of the teaching profession.



## 6.4 Digitalization

Increasingly, schools and education are urged to react to the dynamic societal developments in the field of digitalization. The challenges arising from the COVID-19 pandemic are another reminder of the necessity for schools and teachers to include digital learning with innovation and efficiency. Looking at international developments, Germany has fallen behind in digitalization (Eikermann et al., 2019). Current challenges range from schools' and universities' technical equipment, educational theories and methodologies, to critical ethical perspectives on digitalization processes.

To integrate digitalization topics in teacher education at the University of Tübingen, a new Center for Digitalization has been created. The center is led by the Chair of Teaching and Learning with Digital Media, which has also been funded by the Quality Initiative Teacher Education. The Center allows research to be conducted within the broad spectrum of teaching and learning with digital media in a structured and sustainable way. The overarching challenge is to prove the benefit and efficiency of using digital media, as opposed to more traditional methods. Research in teacher education revolves around the 'TPack-Model' (Technological Pedagogical Content Knowledge), which connects technological knowledge with pedagogical knowledge, content knowledge and pedagogical content knowledge, building an adequate framework for the use of digital media at schools (Mishra & Koehler, 2006).

## 7 Summary and concluding remarks

Education and high-quality teaching are central topics in Germany's society. Reforming or modernizing teacher education depends on multiple structural and practical factors: it requires creating an awareness of urgent societal and educational needs, as well as structured academic expertise to provide high-quality results and implementation in a sustainable way.

The Tübingen School of Education has developed the following model to illustrate how societal needs, teacher education, schools, and the individual citizen build on each other (Figure 3).

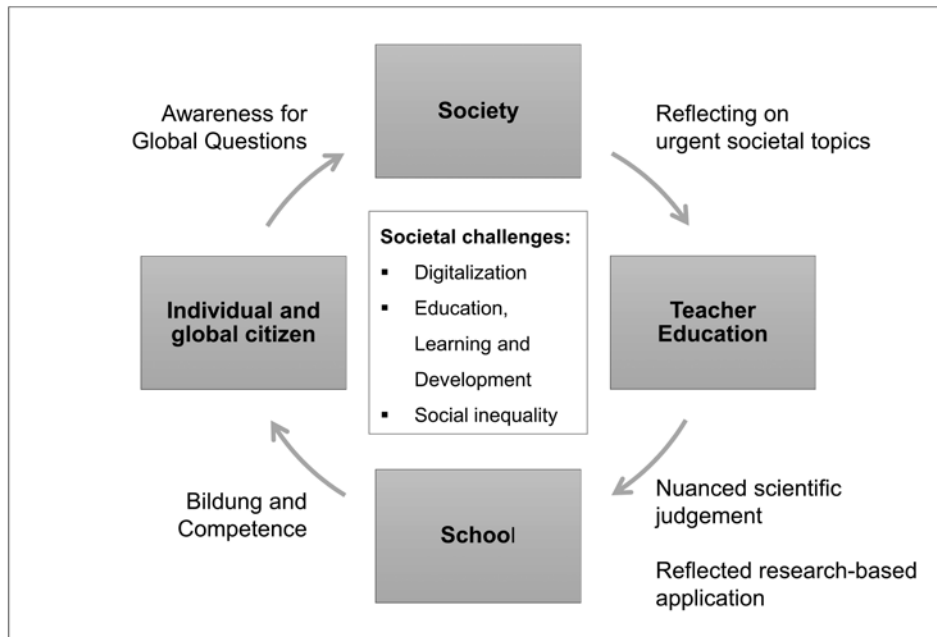

*Figure 3 Societal needs and teacher education*

Societal and educational changes and challenges are constantly imposed on teacher education. Recent examples of emerging topics in teacher education are the above-mentioned areas of digitalization and inclusion. During the last 10 years, both fields have been systematically incorporated into teacher education at German universities, supported by strategic university decisions and additional funding. Successful future-oriented teacher education enables teachers to contribute to evolving structures and professionally work with upcoming challenges at schools.

This chapter has given an overview on the challenging and ongoing change processes of teacher education at the University of Tübingen, as implemented by the Tübingen School of Education and its multiple partners. Developing and conducting high-quality, research-based and up-to-date teacher education is an ongoing process of negotiation between academia, society, stakeholders in schools and school administration, and the government. During the last years, the University of Tübingen has put enormous means and effort into this change process. The success of this process builds the foundation for the ability of our younger generations to master future challenges – on the local and the global level.

## Literature

- Bauer, J., Diercks, U., Rösler, L., Möller, J., & Prenzel, M. (2012). Lehramtsstudium in Deutschland: Wie groß ist die strukturelle Vielfalt? [Teacher education program in German: How great is the structural diversity?]. *Unterrichtswissenschaft*, 40, 101–120.
- Baumert, J. (2006). Was wissen wir über die Entwicklung von Schulleistungen? [What do we know about the development of school performance?]. *Pädagogik*, 58(4), 40–46.
- Biesta, G. (2002). Bildung and Modernity. The future of Bildung in a world of difference. *Studies in Philosophy and Education*, 21(4), 343–351.
- Bleckmann, P., & Lankau, R. (Eds.) (2019). *Digitale Medien und Unterricht. Eine Kontroverse* [Digital media and teaching. A controversy]. Beltz.
- Blömeke, S. (2009). Lehrerausbildung in Deutschland [Teacher education in Germany]. *PÄD-Forum: unterrichten erziehen*, 37 (28), 1, 5–8.
- Blömeke, S. (2006). *Struktur der Lehrerausbildung im internationalen Vergleich: Ergebnisse einer Untersuchung zu acht Ländern* [Structure of teacher education in international comparison. Results of a study on eight countries]. Beltz.
- BMBF (2016). *Neue Wege in der Lehrerbildung: Die Qualitätsoffensive Lehrerbildung: Bundesministerium für Bildung und Forschung* [New ways in teacher education: The quality initiative in teacher education: Federal ministry of education and research]. [https://www.qualitaetsoffensive-lehrerbildung.de/files/Neue\\_Wege\\_in\\_der\\_Lehrerbildung.pdf](https://www.qualitaetsoffensive-lehrerbildung.de/files/Neue_Wege_in_der_Lehrerbildung.pdf).
- BMBF (2020). *Information about the Qualitätsoffensive Lehrerbildung in English*. [www.qualitaetsoffensive-lehrerbildung.de/english-2294.html](http://www.qualitaetsoffensive-lehrerbildung.de/english-2294.html) [23.09.2020].
- Bohl, T., & Beck, N. (2020). Aktuelle Entwicklungen in der institutionalisierten Lehrerinnen- und Lehrerbildung [Current developments in institutionalised teacher education]. In C. Cramer, J. König, M. Rothland & S. Blömeke (Eds.), *Handbuch Lehrerbildung* (pp. 66–75). Klinkhardt / Utb.
- Boban, I., & Hinz, A. (2003). Der “index for inclusion” – eine Möglichkeit zur Selbstevaluation von “Schulen für alle” [The “index for inclusion” – A possibility for the self-evaluation of “schools for all”]. In G. Feuser (Ed.), *Integration heute – Perspektiven ihrer Weiterentwicklung in Theorie und Praxis* (pp. 37–46), Peter Lang.
- Booth, T., & Ainscow, M. (2017). *Index for inclusion. Ein Leitfaden für Schulentwicklung* [Index for inclusion. A guide for school development]. Beltz.
- Brovelli, D., & Kley, A. (2018). Interdisziplinäre Sichtweisen auf die Verschränkung von Fachwissenschaft, Fachdidaktik und Bildungswissenschaft in Lehrerbildungscurricula [Interdisciplinary perspectives on the interweaving of subject science, subject didactics and educational science in teacher education curricula]. *Lehrerbildung im Spannungsfeld der Diskurse*, Nr. 1–2.
- Büchler, T. (2016). Schulstruktur und Bildungsungleichheit: Die Bedeutung von bundeslandspezifischen Unterschieden beim Übergang in die Sekundarstufe I für den Bildungserfolg. *Kölner Zeitschrift für Soziologie und Sozialpsychologie*, 68, 53–87. <https://doi.org/10.1007/s11577-015-0350-5>.
- Bundesverband Deutscher Stiftungen (2019). *Zahlen und Daten* [Numbers and data]. <https://www.stiftungen.org/stiftungen/zahlen-und-daten.html> [30.11.2020].
- Cramer, C., Harant, M., Merk, S., Drahmman, M., & Emmerich, M. (2019b). Meta-Reflexivität und Professionalität im Lehrerinnen- und Lehrerberuf [Meta-reflexivity and professionalism in teacher education]. *Zeitschrift für Pädagogik*, 65(3), 401–423.
- Cramer, C., Johannmeyer, K., & Drahmman, M. (Eds.) (2019a). *Fortbildungen von Lehrerinnen und Lehrern in Baden-Württemberg* [In-service training for teachers in Baden-Württemberg]. Gewerkschaft Erziehung und Bildung (GEW) Baden Württemberg. Tübingen.
- Dedering, K. (2013). Staat, Stiftungen und Schulentwicklungsberater. Zur Handlungskoordination alter und neuer Akteure im Bildungsbereich [State, foundations and school development consultants. On the coordination of old and new actors in the education sector]. *Bildung und Erziehung*, 3, 331–348.
- Eickelmann, B., Bos, W., Gerick, J., Goldhammer, F., Schaumburg, H., Schwippert, K., Senkbeil, M., & Vahrenhold, J. (Eds.) (2019). *ICILS 2018 #Deutschland – Computer- und informationsbezogene Kompetenzen von Schülerinnen und Schülern im zweiten internationalen Vergleich und Kompetenzen im Bereich Computational Thinking* [ICILS 2018 #Germany – Computer and information-related competencies of students in the second international comparison and computational thinking competencies]. Waxmann.
- Fend, H. (2008). *Neue Theorie der Schule. Einführung in das Verstehen von Bildungssystemen* [New theory of schooling. Introduction to understanding educational systems] (3<sup>rd</sup> ed.). VS Verlag.

- Helsper, W. (2011). Lehrprofessionalität – der strukturtheoretische Professionsansatz zum Lehrberuf [Teacher professionalism – The structural theoretical professional approach to the teaching profession]. In E. Terhart, H. Bennewitz & M. Rothland (Eds.), *Handbuch der Forschung zum Lehrberuf* (pp. 149–170). Waxmann.
- Herzmann, P., & König, J. (2016). *Lehrerberuf und Lehrerbildung* [Teaching profession and teacher education]. Julius Klinkhardt.
- Kalthoff, H. (2020). Soziologie in der Lehrerinnen- und Lehrerbildung [Sociology in teacher education]. In C. Cramer, J. König, M. Rothland & S. Blömeke (Eds.), *Handbuch Lehrerbildung*, (pp. 66–75). Klinkhardt / utb.
- Koller, H. C. (2017). Bildung as a transformative process. In A. Laros, T. Fuhr & E. W. Taylor (Eds.), *Transformative learning meets Bildung*. International issues in adult education. Sense Publishers.
- Keuffer, J. (2010). Reform der Lehrerbildung und kein Ende? Eine Standortbestimmung [Teacher education reform and no end? An assessment of the current situation]. *Erziehungswissenschaft*, 21, 51–67.
- Klemm, K. (2019). Alles für die Katz? Neue Belastungen durch den aktuellen Lehrermangel [All for nothing? New pressures from the current teacher shortage]. In *Pädagogik*, 71(7–8), 62–75.
- Kultusministerkonferenz (2004). Standards für die Lehrerbildung: Bildungswissenschaften: Kultusministerkonferenz der Länder [Standards for teacher education: Educational sciences: Kultusministerkonferenz of the federal states].
- Kultusministerkonferenz (2019). *Sachstand in der Lehrerbildung* [State of teacher education]. <https://www.kmk.org/themen/allgemeinbildende-schulen/lehrkraefte/lehrerbildung.html> [05.11.2019].
- Leuders, T. (2020). Kohärenz und Professionsorientierung in der universitären Lehrerbildung. Hochschuldidaktische Impulse durch das 4C/ID-Modell [Coherence and professional orientation in university teacher education. University didactic impulses through the 4C/ID model]. In J. Kreuz, T. Leuders & K. Hellmann (2020), Professionsorientierung in der Lehrerbildung. Springer Fachmedien.
- Lindmeiner, C., & Lütje-Klose, B. (2015). Inklusion als Querschnittsaufgabe in der Erziehungswissenschaft [Inclusion as a cross-sectional task in educational science]. *Erziehung*, 51(26), 7–16.
- Lipowsky, F. (2006). Auf den Lehrer kommt es an. Empirische Evidenzen für Zusammenhänge zwischen Lehrerkompetenzen, Lehrerhandeln und dem Lernen der Schüler [It's all about the teacher. Empirical evidence for links between teacher competencies, teacher action and student learning]. In C. Allemann-Ghionda & E. Terhart (Eds.), *Kompetenzen und Kompetenzentwicklung von Lehrerinnen und Lehrern*. *Zeitschrift für Pädagogik*, 51 (suppl.), 47–70. Beltz.
- Mishra, P., & Koehler M. J. (2006). Technological pedagogical content knowledge: A framework for teacher knowledge. *Teachers College Record*, 108(6), 1017–1054.
- Liebau, E. (2009). Aufgaben und Funktionen der Schule im 21. Jahrhundert [Tasks and functions of the school in the 21<sup>st</sup> century]. S. Blömeke, T. Bohl, L. Haag, G. Lang-Wojtasik & W. Sacher (Eds.), *Handbuch Schule* (pp. 111–119). Klinkhardt / utb.
- Monitor Lehrerbildung (2020). Monitor Lehrerbildung [Monitor teacher education]. <https://www.monitor-lehrerbildung.de> [11.07.2020].
- Prenzel, A. (1993). *Pädagogik der Vielfalt. Verschiedenheit und Gleichberechtigung in Interkultureller, Feministischer und Integrativer Pädagogik* [Pedagogy of diversity. Diversity and equality in intercultural, feminist and integrative pedagogy]. Leske + Budrich.
- Ridderbusch, J. (2019). *Deutschland auf dem Weg zum zweigliedrigen Schulsystem* [Germany on the way to a two-tier school system]. Springer Fachmedien.
- Rott, D., Zeuch, N., Fischer, C., Souvignier, E., & Terhart, E. (Eds.) (2018). Dealing with diversity. Innovative Lehrkonzepte in der Lehrer\*innenbildung zum Umgang mit Heterogenität und Inklusion [Dealing with diversity. Innovative teaching concepts in teacher education for dealing with heterogeneity and inclusion]. Waxmann.
- Sandfuchs, U. (2004). Geschichte der Lehrerbildung in Deutschland [History of teacher education in Germany]. In S. Blömeke, P. Reinhold, G. Tulodziecki & J. Wildt (Eds.), *Handbuch Lehrerbildung* (pp. 14–36). Klinkhardt.
- UNESCO (2009). *Policy Guidelines on Inclusion in Education*. Paris.
- University of Tuebingen (2019/2020). *Statistik und Datenerfassung*. Wintersemester 2019/2020. [Statistics and data]. <https://uni-tuebingen.de/en/597> [07.09.2020].
- v. Ackeren, I., Klemm, K. & Kühn, S.M. (2015). Entstehung, Struktur und Steuerung des deutschen Schulsystems [Development, structure and management of the German school system] (3<sup>rd</sup> ed). Springer.
- Zuber, J., Altrichter, H., & Heinrich, M. (2019). Bildungsstandards zwischen Politik und schulischem Alltag [Educational standards between politics and everyday school life]. Springer Fachmedien.



## Chapter 3

# How Do Schools of Education Position Themselves Within the South African Higher Education Sector: The Case of the Wits School of Education

Elizabeth Mavhunga, Felix Maringe and Reuben Dlamini

*In this chapter, we reflect on how Schools of Education position themselves for identity and acknowledgement globally, and how this applies in the context of a top-ranked South African university, Wits University, which asserts a research-led identity and vision. We look closely at the Wits School of Education (WSoE), whose origins are rooted in a policy process of re-structuring the higher education landscape under the first democratic government. After a brief historical summary of teacher education and its transformation, we give an overview of the policy for the development of teachers in South Africa, and proceed with the WsoE's development of sustainable research capacity. We outline and reflect on the effect of the School's research development strategies, which include the School's rebranding of its vision, institutional re-structuring, and an expanded research-collaboration footprint to include the Tübingen School of Education, whose research strategy is outlined in Chapter 2. The chapter closes with recommendations for continued developments.*

### 1 Higher education policy in the South African context: past and present

The Schools of Education in South Africa came about through a contentious policy process of re-structuring the higher education landscape under the first and newly-appointed democratic government. In the days of the Apartheid government, teacher

<http://dx.doi.org/10.15496/publikation-76384>



education took place largely in institutions called Colleges of Education (Cross, 1986). In the 1960s, these Colleges were purposely proliferated in the “homelands”: designated rural and isolated areas of the country that have poor economic activity (Jensen & Zenker, 2015). Homelands were built on discriminative principles, dividing the black community further along ethnic lines, as each homeland was assigned to a specific ethnic group. The governance and economic empowerment in these homelands were notoriously weak and inconsistent. The Apartheid state created silent but brutal competition between the different homelands, which consequently filtered into the embedded Colleges of Education, for access to funding and infrastructural development. As a result, some colleges were internally better equipped than others, thereby promoting the divisive policies of the Apartheid government along administration lines.

In the early 1990s, following the debut of the democratic government order, policy reviews of many economic sectors for a post-Apartheid South Africa, including education, were prioritized. These were epistemologically driven by the long-standing desire for redress, the eradication of social inequities, and the restoration of the marginalized black community's dignity (Clercq, 2020). Immediately after April 1994's democratic elections, the government, through a presidential proclamation process, established a national commission into higher education (NCHE) in the December of the same year. Its terms included advising the government on issues related to the re-structuring of higher education for a post-Apartheid South Africa, and its re-calibration for a successful repositioning within global education economies.

In this context, the perspectives on the Colleges of Education at that time were not positive (Jansen, 2003). Policy debates were polarized between retaining the Colleges of Education and merging them with higher education institutions. Ultimately, the decision favored their abolition through a merger process that incorporated the 109 Colleges of Education into 22 of the 26 newly merged public universities. The reasons offered for merging rested on two major factors: the aforementioned political redress and institutional administration efficiency. Firstly, the arguments for political re-dress were overwhelmingly driven by the desire to resolve the Apartheid legacy, focusing on the need to eradicate racial segregation and discrimination by integrating the education system into a single coherent instrument (Baloyi & Naidoo, 2016). Secondly, the consolidation of the unequal Colleges of Education, which were scattered across the country, into a few institutions, was to achieve economies of scale through reducing unit costs and economies of scope, enabling presence and footing in global discourses (Cloete & Muller, 1998; Jansen, 2003; Mzangwa, 2019). Despite the unitary legislation that ushered in the proclamation of the mergers, the participating parties did not

have the benefit of a neat, theoretically supported antecedence. They had to plough through the complex cultural differences, power imbalances, and staff anxieties in multiple different ways (Jansen, 2003), some of which continue to bedevil the identity of Schools of Education within the higher education sector. These will be made clearer with reference to the Wits School of Education (WSoE) as we unpack its institutional development.

Today, the task of initial teacher education primarily rests with public universities regulated and monitored by the legislative principle and procedure, in accordance with the 1997 Higher Education Act (Act 101 of 1997). The legislation states that “it is desirable for the HEIs [Higher Education Institutions] to enjoy freedom and autonomy in their relationship with the state within the context of public accountability and the national need for advanced skills and scientific knowledge” (Department of Higher Education Act 101 of 1997, p. 2). While autonomy is granted, the government, through the Ministry of Education, monitors, supports and regulates processes and policies applied in the HEIs. As mentioned earlier, the merger of the Colleges of Education into universities took different forms. In this Chapter, we highlight the institutional development of the WSoE as a sub-unit within a university that asserts a research-intensive identity in its vision and culture. We examine the institutional development of the School as a College of Education that was determined to shape its identity as it entered the merger with our university, Wits University.

The School was then known as the Johannesburg College of Education (JCE) and strove for what Jansen (2003) called the protected enclosure kind of merger. Through exceptionally strong leadership, the School argued for favorable terms of incorporation that ensured the School would remain physically intact as a unit with its own designated campus. Among the achievements were the ring-fencing of its financial reserves for the purposes of teacher education; the negotiation of professorships for its senior staff; and the defying of long-standing rules for academic professorship. The School headship was also considered as the Dean of the Faculty of Humanities, thereby elevating the school to a faculty in its own right. No other College-University merger achieved such a feat at the time. The School operated as what Jansen (2003, p. 35) called a ‘quasi-independent facility’ for the specific training of pre-service teachers. While this arrangement did not mean that the School disregarded the university regulations, it did mean that the School had managed to buy transitional time to settle in and shape its identity and legitimacy within the larger institution.



## 2 The WSoE in the contemporary higher education landscape

Despite the institutional success achieved through the transitional protective enclosure, as with many cases globally, the WSoE experienced a difficult road to retaining and bolstering its legitimacy within the wider university. As Marques and Powell (2020) point out, the demise of the Schools of Education generally resulted from the wider university's lack of understanding of education studies. Education is a multidisciplinary field that focuses on both education knowledge and the practice of disciplines that, in some cases, have conflicting views and impermeable territorial discipline boundaries (Lawn & Furlong, 2009). As such, the integration of Schools of Education into South African universities has predominately taken shape via two distinct models.

The first is a centralized model in which a School of Education is exclusively a stand-alone sub-unit of the university, with provisions for both content courses and pedagogy all offered under one roof. The second is a decentralized model in which a School of Education focuses mainly on the provision of pedagogy and the related practices. Content courses are taught at the originating academic disciplines in different faculties across a university. The WSoE employs the centralized model for the provision of programs in both the undergraduate and postgraduate degrees. As with many Schools of Education around the world, the WSoE teacher education curriculum names the subjects of specialization according to the originating academic disciplines. Subjects of specialization include those that are taught in the four phases of the South African School education system. These are: the foundation phase (Grades R–3); the intermediate phase (Grades 4–6); the senior phase (Grades 7–9); and the exit phase, further education and training (Grade 10–12). The teaching of the subjects of specialization is accompanied by pedagogical methodological courses fostering a range of educational aspects grounded in a theoretical framework that describes teacher knowledge for teaching—Pedagogical Content Knowledge (PCK). The teacher education curriculum entails a policy-regulated ratio of theoretical learning and learning through school-based teaching experience.

The centralized model, combined with the School's location outside of the main campus, has had a downside for the School's visibility. Time and again, it is like a 'lost child', with fewer spontaneous institutional interactions with the wider university community, other than through the administration link of the Faculty of Humanities and sparse pockets of research collaborations at an individual level. The result of these perceptions is the School's continuous struggle for recognition of the unique governance dynamics resulting from its large size, which earned its faculty status at some

point. In particular, this is a struggle for the recognition of its role in navigating the adverse socio-economic impact on students, and for its conceptual existence as an academic discipline with important contributions to research and the generation of new knowledge within the humanities. Marques and Powell (2020) remind us that the battle for recognition of education's legitimacy as a discipline is not only a local issue, but also a global one. It stems from the tensions between the academic field and the field of practice (Biesta, 2011). In the sections below, we unpack how the WSoE, as a force of recognition, asserted its legitimate presence within the complex structure of a higher education institution that has asserted its identity as a research-intensive university.

### 3 Institutional shaping forces

In order to understand the strategic shifts within the WSoE as it re-positioned itself for increased reputational recognition, we drew on Marques and Powell's (2020) conceptualization of the School of Education as an 'organizational strategic actor' (OSA) within the wider university institution. OSA is a term that originates from Krücken and Meier's arguments (2006). According to these authors, OSAs commonly find themselves competing not only for material resources such as funding, but also for symbolic resources such as a favorable reputation profile and legitimate recognition of their existence. While this competition is inherent to the university institution, it also extends externally into the broader field, such as the higher education sector.

External factors such as the dwindling funding, as well as the rating and rankings of the university research outputs, have all placed enormous pressure on universities as institutions. The interconnectivity between funding and the research evaluation system, which uses the research rating system to distribute research funding according to criteria and indicators of quality judged by peer review, has intensified the competition among universities. In this system, peer-reviewed research is perceived as a commodity, the currency of academia, and is increasingly judged not in terms of intrinsic worth, but in terms of its performative measures and income generation (David, 2019). Marques and Powell (2020, p. 837) add that the evolution of scrutiny by media such as Times Higher Education, which are ranking universities' performance and that of sub-units such as faculties and Schools, can be understood as "shaping forces" that exacerbate the competitiveness of the environment in which universities and Schools are embedded. Unlike in a commercial market, the competition created

by the ranking system among universities and their sub-units is being managed and controlled by a third party, for instance the media organization and Higher Education Funding Councils, which set the framing for the competition in the place of consumer needs. At the time of writing this chapter (2021), the WSoE has been competitively ranked as 3<sup>rd</sup> in the list of best public Schools of Education in the African continent by the Times Higher Education, and located within the 201–250 bracket of the 400 plus list of global universities by the Times Higher Education subject rankings.

We further acknowledged two perspectives that conceptualize university positioning as a social construct (Maringe, 2006). These are the environmental determinism perspective and the managerial rationality perspective. The former is developed, similar to Krücken and Meier (2006), around the quest for legitimacy in order to comply with the pressures of the surrounding environment. In this case, legitimacy is seen as more important than efficiency in sustaining organizational survival (Mampaey, Huisman & Seeber, 2015), making universities more inclined towards using exogenous influences as a rationale for adaptation and compliance in the educational environment. Key factors of the external environment might include the political pressure, such as the pressure to produce certain types of graduates, or in this case, teachers in specified numbers, in order to meet systemic teacher needs and requirements. The external environment might also include resource availability, for example, government funding for certain types of programs, such as teacher preparation programs, as is the focus of the WSoE and other Schools of Education such as the Tübingen School of Education (see Chapter 2). But it could also include significant international pressure to produce graduates with global skills, such as those for the 21<sup>st</sup> century in the context of the 4 IR. Institutions thus seek legitimacy in the extent to which they can demonstrably show relevance to such external environmental forces.

The second perspective, the managerial rationality perspective (Mampaey et al., 2015), posits internal purposiveness led by the thoughts and actions of the institution's senior leaders. In the case of the WSoE, this internal rationality arises from the pressure to be a legitimate part of a demonstrably research-intensive university with aspirations for global eminence. The WSoE has developed its vision as a research-led professional School focusing on research as the overarching pillar. Managerial rationality, in this case, is thus seen as a strategic process that responds to internal organizational pressure for conformity and legitimacy (Fumasoli & Lepori, 2011).

#### 4 Re-positioning of the WSoE to lead

In the last five years (2016–2021), the WSoE has persistently emphasized the development of emerging, upcoming researchers, as well as the professional development of a specific cohort of academic staff without doctoral degrees. A large proportion of this cohort has come through the historical ‘protective closure’ merger arrangement mentioned earlier, which was introduced at the inception of the School. It is in the last 2 years of the same period that the School, under new leadership, purposefully re-asserted its identity (Mampaey et al., 2015) by renewing its vision as a research-led School of Education. This vision was immediately matched with a vigorous implementation strategy that saw the rebranding of the School, in line with the isonymism associated with the battle for gains in symbolic resources, particularly reputation and legitimacy (Marques & Powell, 2020).

Some of the vocabulary used in the formulation of the vision is similar to the criteria used in the national and global instruments for ranking. In our School's case, the words ‘research-led’, ‘high-impact’, and ‘visibility’ found their way into the statements describing key operational components of a professional teaching school. In contrast to the trend observed with the branding of leading and top-ranked Schools of Education, and despite the School's high position in the ranking of African Schools of Education (Higher Times Education, 2021), the School adopted a developmental approach, rather than an affirming position of leadership and rank (Marques & Powell, 2020). Part of the reason for this was the fruitful impact of efforts to develop early career researchers, who were continuously bolstered by the presence of a group of esteemed scholars. The latter were cream-of-the-crop achievers and highly ranked in their own right. Additionally, it was due to the recognition that this crop of scholars was leaving the School due to retirements, resignations and emigration. At the same time, the School was experiencing growth in student numbers, resulting in large classes and high workloads, while the funding prospects that would have allowed those leaving to be replaced with scholars of the same academic rank were shrinking. A perceived pattern of juniorization was emerging, as the School turned to replacing higher ranked academics with multiple junior academics (Nettelbeck, Hajek & Woods, 2012).

It is for this reason that the strategic re-branding of the School had to be matched with an equal and continued emphasis on professional development and support. Equally important was developing an organizational culture of unity, belonging and caring that would knit the different components of the new vision together. To this end, the School underwent internal organizational re-structuring, resulting in the elevation of

three previously existing major operational portfolios considered to be drivers of change. These are Research, Graduate Studies and Teacher Education Programs. While each of these portfolios had unique, independent roles, the magic was in their outlook for seamless interactivity, which enabled a smooth delivery of research-led teacher education. The Research portfolio experienced the most structural overhaul compared to the other two portfolios, since they have ties with teaching programs that are bound by tighter university policies and accreditation requirements. The resulting structural change marked the beginning of a new culture of research activeness within the School.

## 5 Re-structuring research at the WSoE

As a School that was becoming academically younger, moving towards the research-led vision and also defending the rich historical reputation it has inherited, all the operational components had to be harmonized to function effectively, while also establishing a sense of continuity (Bak & Kim, 2015). Drawing on previous internal analyses regarding the nature of research work conducted at the School, seven broad themes emerged, which were translated into research structures called 'Research Thrusts' (RTs). The RTs became the virtual organizational research structure that overlaid and freely intercepted the traditionally fractionalized teaching disciplines. A Research Thrust had to have (i) members from more than one discipline, so as to facilitate collaboration between multiple disciplines and increase the potential for large-scale research. Furthermore, the research conducted in a Research Thrust had (ii) to show increased articulation with local or global education and socio-economic challenges, so as to increase the impact factor of the research produced by the School. Membership in a Research Thrust was voluntary and disposed to a healthy mix of both seasoned and emerging researchers. In adopting this approach, the School reciprocally fostered cultural tolerance, the ethnic and gender diversity favoring institutional cultural transformation. The formation of themed RTs further encouraged internal discourse for large-scale research projects based on cross-cutting themes such as Assessment and Technology in Education, thereby enlivening the desired teaching-research nexus (Bak & Kim, 2015). The RTs also doubled up as academic developmental hubs, through which the School's financial and other resources could be accessed and channeled accountably to support the research vision.

The organizational restructuring of research in the School gave a voice and visibility to a traditionally silent research presence, which was often conducted in silos and whose

output was known to few. These outputs were discussed more in human resource activities, such as probation and promotion meetings. In the new structure, the articulation between the RTs and the Research Committee of the School was strengthened. The Research Committee brought a new role: supporting and promoting the visibility of the research work conducted within the RTs. The main strategy for this was putting on designated, promotional School-wide seminar events throughout the year.

Two prominent events are 'Research in the School of Education' (RiSE) and the 'Research Bonanza'. RiSE aims at creating an institutional culture of celebrating research activeness and fosters the dissemination of newly published research outputs. At a RiSE event, authors of new publications are given an opportunity to promote their outputs through presentations and visualization on displays. The event further serves as a formalized process for capturing the School's subsidy-bearing publications throughout the year. On the other hand, the Research Bonanza targets the research work of all academics and graduate students who are afforded an opportunity to present their publications and work in progress. Included in the Research Bonanza are opportunities for hands-on workshops. The School's activities, particularly teaching, come to a complete halt over a 2-day period in order to give precedence to a vibrant and a festive research moment. The event is strategically opened to the wider university as part of what Marques and Powell (2020) call a continual fight for legitimacy. The event is also open to the participation of important external strategic partners such as the sister Schools of Education within the Province, and the Provincial Department of Basic Education. Both the RiSE and the Research Bonanza promote the renewed vision by heightening the visibility of the research work within the School.

As with many Schools of Education, such as with the Tübingen School of Education, the WSoE has, in its journey of renewal and the foregrounding of the refreshed research-led identity, packaged itself in narratives with prestige words (Sidhu, Ho & Yeoh, 2011), which have become instrumental in attracting attention. However, what is unique to the School is the purposeful decision to adopt a developmental role in re-building its research portfolio. The re-structuring of the research portfolio by forming themed RTs has facilitated access to academic research scholarships, while reciprocally giving attention to the attainment of institutional goals for research visibility and impact. An equally important element in this journey has been securing infrastructural facilities that have 'the look and the feel' that support the vision. However, this goal has required innovative strategies for securing funding.

## 6 The Wits School of Education: Funding

A majority of South African universities are state-owned, so the government is expected to subsidize them, while also sponsoring eligible low-income students through the National Student Financial Aid Scheme (NSFAS). Funding in higher education, especially in South Africa, is linked to issues of accessibility, cultural capital, and intellectual capital. In recent years, cracks have begun to surface in the funding of higher education, despite the established history of cost sharing in South Africa post-Apartheid (Wangenge-Ouma, 2012). Higher Education Institutions (HEIs) have been experiencing unprecedented fiscal constraints in the face of a ballooning student enrolment. While this development signifies a major policy improvement in re-dressing the ills of the past Apartheid regime through wider access to higher education, it has also introduced new developmental constraints. Against the backdrop of our country's poor economic growth over the last 5 years, as well as the new demand for online provision of education due to the COVID-19 pandemic, the economic segregation between well-resourced and poorly-resourced universities has been heightened. In an effort to meet the financial and resourcing demands, universities have turned to student tuition fees, placing enormous pressure on students, especially those from working-class families. These socio-economic conditions have favored the emergence of private business practices within universities, threatening the fundamental goal of education for the public good (Dlamini, 2018). Thus, there is an inherent conflict in reducing higher education to what Natale and Doran (2012) termed the "contemporary face of education" (p. 187), which leans towards the commercialization of education. While we are cautioning against this commercialization, we have no doubt in the possibility of public good and the market-oriented approach to tertiary education co-existing. However, to avoid structural discrimination and low participation of the historically disadvantaged, their implications for values must be confronted and balanced.

The WSoE has remained resolute in maintaining the fine balance between the HEIs' intentions to reform and recalibrate, and the encouragement of participation by funders. The School derives its funding from the university central budget and through third stream income. As a result of dwindling budgets for operational activities and student funding challenges, the School has created a position known as 'Academic Head Funding and Innovation'. Fundraising activities to support students and procure resources required the synergy of creative strategies to ensure successful results in the new position. Given that generally, there are very few corporations aligned with initial teacher education, the WSoE had to be very creative and innovative in its

drive for funding. Unlike other Schools in the university, which have significant interaction with industry by commercializing new technologies originating from academic research, the School of Education's mandate is to produce high quality teachers. The commercialization of new technologies in other Schools resulted in extra funding for student bursaries, infrastructural development, and research activities from concept to application in society (Cullen, Calitz & Chetty, 2020). It is for these situational reasons that the establishment of the Academic Head Funding and Innovation portfolio was inevitable.

The School relied on the funds generated through the portfolio to pursue innovative ways of mitigating financial barriers to support student bursaries and staff development, particularly early-career academics. The operational strategy, driven by the head of the Funding and Innovation portfolio, was to pursue heads of division in the School, in order to develop short courses and long-term projects as part of the third stream income. A short course policy was developed on the financial sharing ratio with the Head of School and the Business & Finance Manager, and was approved by the Schools' executive committee. The financial sharing ratio meant that the school retains 60% of the profit, while the division was given access to 40% to be used for research activities, human capital development, and conference participation.

In addition to this, the benevolent fund was established. Staff in the School contributed a portion of their salary to support the most marginalized and financially struggling students in the School. Another source of income was CORY (Cost Recovery), a percentage amount charged in research and externally funded consultancy projects as part of the Schools' public mandate on community engagement and beneficitation. These diversified sources of income allowed the School to provide a supportive, high-quality research environment for academic staff and educational environment for students. The creation of a supportive and empowering environment was in line with the university transformation agenda to ensure inclusiveness. Furthermore, in an effort to bridge the funding gap, the School has maintained positive relations with the philanthropic community at a local and international level. All this shows that the School has, in the face of diminishing resources, remained resolute in responding to issues of access, inclusivity and forward thinking. In this context, the development of a purpose-driven infrastructure precinct is an example of the School's forward thinking towards innovation.



## 7 Infrastructural development and investment

The transition of the WSoE into a research-led School through the innovative virtual RTs was to be accompanied by suitable infrastructure development. This was to create efficient physical spaces for collaboration, transcending the boundaries of the traditional academic disciplines housed in the School's 9 divisions. To achieve this, the WSoE then embarked on a journey to create multiple infrastructural precincts to support research and collaboration among academic staff and postgraduate students. The newly created portfolio of Funding and Innovation became significantly instrumental in securing the needed funds. The funding strategy was thus tied to the RTs' work as the hub of knowledge production and the development of transformative pedagogies. This paid off positively, as intra-university financial support was secured through grants and various research project initiatives. Aware of the deeply rooted institutional structures and cultural norms, the RTs provided an innovative and productive platform for academics to collaborate and share knowledge, with the aim of realizing sustainable education change in a multilevel and interconnected system (Corbo, Reinholz, Dancy, Deetz & Finkelstein, 2016). The RTs were seen by funders as providing a framework for creating and sustaining institutional change to ensure systemic improvement in active teaching and learning practices.

Several signature facilities were created with funds secured through the Funding and Innovation portfolio. One of these is a Research Hub exclusively used by academic staff. There is also a Postgraduate Lounge for postgraduate students. These spaces were strategically refurbished and modernized to provide an environment conducive to knowledge production. They foster an institutional culture that promotes research in practice, where research and teaching activities interactively and reciprocally influence each other. For academic staff, the provisioning of the Research Hub meant a sanctuary for deep thinking and the advancement of research in daytime: a sharp contrast to the traditional experiences of research happening only through the sacrifice of private time. In addition to the research facilities, the School has made noticeable advances towards improving computational technologies to support the transformation of our traditional instructional activities to online learning.

When the progress made by the School with respect to the infrastructural development project are placed within the context of challenges in securing funding in the South African higher education sector, an impressive and warming picture of the School's research-centered future emerges. The new infrastructure has gone a long way in positioning our School, appropriately, at the forefront of innovation against all odds.

## 8 Concluding remarks

We stated the focus of this chapter as offering insight into the struggles and successes of Schools of Education, specifically one located within a university that strives for top global rank among the research-led universities. Looking closely at the journey travelled by the WSoE in asserting its legitimacy, we outlined the forces exerting influence on its being and re-positioning, and make concluding remarks. The School draws its legitimacy from both the exogenous and the endogenous contexts. Its position as an eminent national resource is based on the excellence associated with its leadership in teacher preparation responsibilities, while its internal positioning is strongly aligned with institutional ambitions to become a highly-rated, research-intensive university. The recently experienced global disruption to education due to the coronavirus (SARS-CoV-2) came at the heels of a nascent transformative research journey within the School. It was targeting a reinvigorated research-led focus, unaware of the incoming wave of disruption, which tested not only its will to drive research, but also its resilience. As with many Schools of Education globally, the School's preparedness to retain the desired level of research activity, and gain ground towards realizing the new vision in the face of a global, large-scale disruption, will be judged in time.

The years 2020–2021 were marked by increased stresses related to fully digitalizing learning and teaching. This was a new experience for many of the educators and researchers, who now had to shift focus to the more urgent issue of learners' needs and difficulties with engaging in an online learning environment (Zhong, 2020). As a result, it remains to be seen whether the implemented re-structuring of the research element within the School, as well as the investment into creating a supporting infrastructure and a conducive environment, will bear fruit. However, it is clear that new ways of supporting and cultivating research that is conducted remotely are to be sought. One of these is digital competence and the subsequent resilience to be built. We conclude this chapter by acknowledging that in the face of a changing and constraining education environment, fully realizing the research-led vision will continuously require our collective ingenuity, in order to bounce back from each crisis and bounce forward into a new reality.

## Literature

- Bak, H. J., & Kim, D. H. (2015). Too much emphasis on research? An empirical examination of the relationship between research and teaching in multitasking environments. *Research in Higher Education*, 56(8), 843–860.
- Baloyi, C., & Naidoo, G. (2016). Higher education mergers in South Africa a means towards an end. *African Journal of Public Affairs*, 9, 19–30.
- Clercq, F. d. (2020). The persistence of South African educational inequalities: The need for understanding and relying on analytical frameworks. *Education as Change*, 24, 1–22. <https://doi.org/10.25159/1947-9417/7234>.
- Cloete, N., & Muller, J. (1998). South African higher education reform: What comes after post-colonialism? *European Review*, 6, 525–542.
- Corbo, J. C., Reinholz, D. L., Dancy, M. H., Deetz, S., & Finkelstein, N. (2016). Framework for transforming departmental culture to support educational innovation. *Physical Review Physics Education Research*, 12(1), 010–113. <https://doi.org/10.1103/PhysRevPhysEducRes.12.010113>.
- Cross, M. (1986). A historical review of education in South Africa: Towards an assessment. *Comparative Education*, 22(3), 185–200.
- Cullen, M. D. M., Calitz, A. P., & Chetty, M. A. (2020). Factors affecting researcher participation in technology commercialisation: A South African university case study. *Southern African Journal of Entrepreneurship and Small Business Management*, 12, 1–12.
- David, H. (2019). Publish or perish—perceived benefits versus unintended consequences. *Ergonomics*, 62, 1–3. <https://doi.org/10.1080/00140139.2019.1664131>.
- The Higher Education Qualifications Framework: Higher Education Act (1997). Department of Higher Education South Africa (1997). The Higher Education Qualifications Framework. Higher Education Act No. 101 of 1997. *Staatskoerant* No. 928, 2007.
- Dlamini, R. (2018). Corporatisation of universities deepens inequalities by ignoring social injustices and restricting access to higher education. *South African Journal of Higher Education*, 32(5), 54–65.
- Jansen, J. (2003). Mergers in South African higher education: Theorising change in transitional contexts. *Politikon*, 30, 27–50.
- Jensen, S., & Zenker, O. (2015). Homelands as frontiers: Apartheid's loose ends—an introduction. *Journal of Southern African Studies*, 41(5), 937–952.
- Krücken, G., & Meier, F. (2006). Turning the university into an organizational actor. In G. S. Drori, J. W. Meyer, & H. Hwang (Eds.), *Globalization and organization: World society and organizational change*. Oxford University Press.
- Lawn, M., & Furlong, J. (2009). The disciplines of education in the UK. *Oxford Review of Education*, 35, 541–552.
- Maringe, F. (2006). University and course choice: Implications for positioning, recruitment and marketing. *International Journal of Educational Management*, 20(6), 466–479.
- Mampaey, J., Huisman, J., & Seeber, M. (2015). Branding of Flemish higher education institutions: A strategic balance perspective. *Higher Education Research and Development*, 34, 1178–1191.
- Marques, M., & Powell, J. J. W. (2020). Ratings, rankings, research evaluation: How do Schools of Education behave strategically within stratified UK higher education? *Higher Education*, 79, 829–846.
- Mzangwa, S. T. (2019). The effects of higher education policy on transformation in post-apartheid South Africa. *Cogent Education*, 6, 1–15.
- Natale, S. M., & Doran, C. (2012). Marketization of education: An ethical dilemma. *Journal of Business Ethics*, 105, 187–196.
- Nettelbeck, C., Hajek, J. T., & Woods, A. V. (2012). Re-professionalizing the profession: Countering juniorization and casualization in the tertiary languages sector. *Local—Global*, 9, 60–75.
- Sidhu, R., Ho, K. C., & Yeoh, B. (2011). Emerging education hubs: the case of Singapore. *Higher Education*, 61, 23–40.
- Van Vaught, F. (2008). Mission diversity and reputation in Higher Education. *Higher Education Policy*, 21, 151–174.
- Zhong, R. (2020). *The coronavirus exposes education's digital divide*. <https://www.nytimes.com/2020/03/17/technology/china-schools-coronavirus.html> [10.03.2020].

## Chapter 4

### How Do Schools of Education Position Themselves Within the German Higher Education Sector: The Case of the Tübingen School of Education

Elisabeth Hofmann and Thorsten Bohl

*This chapter introduces the institutional structures of teacher education at the University of Tübingen, Germany. Teacher education at the University of Tübingen is introduced along with the local and regional history of teacher education in Baden-Württemberg. The characteristics and institutional history of the Tübingen School of Education are discussed, as well as the School's aims, identity, and self-portrait: connecting teacher education across all university subjects and implementing research-based teacher education. The TüSE's fields of work are presented: academic affairs and advising, the development of research structures, support structures for young researchers, teacher professionalization, inclusion, and internationalization. The management and work structures, the different committees, statutes, and the mission statement are discussed as central elements that develop and advance teacher education in Tübingen. Finally, this chapter looks at the commonalities and differences of the two Schools of Education in Wits (Johannesburg) and Tübingen. One common characteristic is that both are young institutions and are tasked with their own further development: in addition to their responsibilities for organizational issues and student affairs, both institutions have developed into highly ambitious research centers with a specific interest in supporting young researchers in the fields of PCK and PK.*

<http://dx.doi.org/10.15496/publikation-76383>



## 1 New structures of academic teacher education

The University of Tübingen established the Tübingen School of Education in 2015 as an academic institution that advances and coordinates teacher education based on 'research, relevance and responsibility'. The new School of Education was to be responsible for promoting and integrating innovation and new, challenging topics in teacher education, with close collaboration between all academic subjects involved with teacher education. The development of the Tübingen School of Education took place against the backdrop of national and federal educational jurisdictions, and was brought on because of demands for extensive changes in teacher education, which needed to be addressed systematically at the university, across all faculties and subjects involved with teacher education.

## 2 Jurisdictions for teacher education in Germany and Baden-Württemberg

Germany's educational structures locate teacher education between state departments of education, universities for the academic phase, and seminars in collaboration with schools for the school-based phase.

According to state policy, Baden-Württemberg's Ministry of Science is responsible for universities, while its federal Ministry for Culture, Youth and Sports is responsible for schools. This requires institutions of teacher education to collaborate and coordinate their work with the two ministries.

The University of Tübingen is located in the federal state of Baden-Württemberg and is thus shaped by Baden-Württemberg's unique structures of teacher education. Teacher education in Baden-Württemberg is split between two types of higher education institutions: teachers for primary, lower secondary, and special needs schools study at Universities of Education, while teachers for academic high schools (Gymnasium) and vocational schools study at general universities. This two-fold approach to teacher education creates additional challenges and requires ongoing mutual information and communication. Students who intend to switch their school type during their academic study phase need to plan this carefully and are usually required to catch up with some classes.

The federal states have varied study courses and structures. Until recently, teacher education in Germany led to a state examination degree. This degree reflects governmental influence on and control of certain standards in teacher education. The Bologna Process led to changes in Baden-Württemberg. In 2015, teacher education de-

degrees switched from state examinations to bachelor's and master's structures. The new structures and standards are created and controlled by institutions of higher education, rather than by government departments for education, and even within Baden-Württemberg, there are differences between the study programs, for example regarding their polyvalence.

The changes since Bologna are expected to bring about several improvements: increased student mobility, degrees that are comparable on an international or continental level, and more flexible study programs due to workload descriptions and ECTS points (Blömeke, 2009). The shared characteristics of teacher education can be summarized by two tendencies: teaching degrees (on the secondary school level) focus on two school subjects in addition to educational sciences; and teaching degree programs consist of content knowledge, pedagogical content knowledge, educational sciences and school internships. In Baden-Württemberg, these characteristics are detailed in the Educational Framework for Teaching Degree Programs 2015.

### 2.1 Developments in teacher education that led to Schools of Education being created

Institutionalized teacher education evolved in three phases, which are described here using the example of the University of Tübingen.

During the first phase, which lasted until 2005, all large universities offered teaching degree programs, but there were no central regulations. Only in 2005 were Centers for Teacher Education introduced at universities in Baden-Württemberg, allowing the central coordination of teaching degrees. These Centers of Teacher Education consisted of one staff member and served across the whole university as part of the central administration, with strongly restricted resources. However, the competitive developments in teacher education combined with the higher expectations of future teachers led to extensive changes after 2015. The national funding program “Quality Initiative Teacher Education” (BMBF, 2016) provided massive financial support and led to a re-organization and reevaluation of teacher education as a whole in Tübingen and in the majority of universities across Germany. The Tübingen School of Education was officially launched in 2015, supported by Baden-Württemberg's minister of science, research, and arts.

The following table (Table 1) illustrates the multiple institutional levels, important formal documents, and the actors that shape teacher education.

		Level	Example	Actors (exemplary)
1	Macro-level	Federal	<ul style="list-style-type: none"> <li>–Standards for teacher education: educational sciences (Resolution of the KMK on 16.12.2004, as amended on 12.06.2014)</li> <li>–Requirements common to the federal states for the content of the sciences, humanities and subject didactics in teacher education (resolution of the KMK on 16.10.2008 in the version of 11.10.2018)</li> </ul>	Federal Ministry of Education and Research, Standing Conference of the Ministers of Education and Cultural Affairs (KMK)
2		Federal state	<ul style="list-style-type: none"> <li>–Framework regulation for teacher education programs in Baden-Württemberg (framework VO-KM, 2015)</li> <li>–Basic format of teacher education programs (e.g., state examination or BA/MA)</li> </ul>	Federal Ministers of Education and the Arts
3		University	<ul style="list-style-type: none"> <li>–Location-specific decisions, e.g., on B. Ed. / M. Ed. structure or on general parts of the examination regulations for teacher education programs</li> <li>–Characteristics and structure of teacher education (e.g., Schools of Education, management structures)</li> </ul>	Rectorate, Central Administration, Faculties, School of Education / Centers for Teacher Education
4	Meso-level	Faculties and central schools for teacher education / Centers for Teacher Education	–Study and / or examination regulations (e.g., specified in a special section)	Deans of Studies, Central Administration, Staff of the School
		Subjects and disciplines	–Module handbook	Specialist representatives
5	Micro-level	Academic personnel	–Planning and design of individual courses	Lecturers of sciences, subject didactics and educational sciences
6		Interaction	–Concrete, planned or unplanned interaction between participants of a class	Lecturers and students

*Table 1 Institutional levels influencing the academic phase of teacher education (adapted and translated from Bohl & Beck, 2019)*

### 3 Reforming teacher education by creating change from within

Aspirations to advance the situation of teacher education in Germany have been discussed since 2000, when a commission of the Standing Conference of the Ministers of Education and Cultural Affairs (KMK) recommended developing Centers of Teacher Education, these being strategic players with insight and influence into all questions of academic teacher education. They recommended setting up institutions that work across faculties and departments in order to represent teacher education as a whole, including research, academic affairs, advising, coordination and support services. Only a year later, the German Research Council suggested something similar: developing institutions responsible for covering all aspects of teacher education including coordination, the creation of ideas, and cultivating new ways. (Böttcher, 2015).

The recommendations expressed the urgent need for reform and the institutionalization of teacher education from within universities. Many of the suggestions were realized in 2015, when the Quality Initiative Teacher Education (Qualitätsoffensive Lehrerbildung) was launched. This allowed universities to bid for funding and to devise an individual solution according to the guidelines of the funding ministry—the national, state ministry of education and research.

By creating an academic institution, the School of Education, ensured that teacher education would be advanced and developed in a research-based way, guided by researchers and experts, based on theoretical and empirical knowledge, and supported by ongoing research, assessment and reflection on the evolving structures and upcoming decisions. The approach aimed at encouraging innovation from within a century-old institution, requiring careful decisions and long discussions on how best to approach the task. In the following section, the developments and strategic decisions are described:

The starting shot of the Tübingen School of Education was fired in 2012, when the rector of Tübingen University, while attending a public convention, first spoke of the new “Tübingen way” and of “teacher education from a single mold”. Behind this was a reason specific to Baden-Württemberg: the other significant sites of university teacher education, namely Heidelberg, Freiburg, and Stuttgart, had founded a joint School of Education with their respective local Pedagogical Universities. However, since there is no Pedagogical University in the regional vicinity of Tübingen, its School of Education had to be established on its own. The main issue was how to finance professorships for subject didactics, which were available at the Pedagogical Universities, but not at universities in Baden-Württemberg. At universities in Baden-Württemberg, subject studies had until then been largely shaped by subject-specific re-



search. Subject didactical courses were not offered by professors and lecturers at the university, but were imported from the second phase of teacher education, the so-called Seminars for Didactics and Teacher Education. This meant that the universities lacked the original subject didactical research and research-based teaching. With the proclamation of the “Tübingen way”, strategies and measures were connected that led to a new institutional form of Tübingen teacher education. The work of the Tübingen School of Education includes close collaboration with representatives from the above-mentioned Seminar for Teacher Training and Continuing Education, ensuring that the research-based and school-based phases of teacher education are closely intertwined. The German developments in teacher education reflect the need for universities to fuse tradition and high academic standards with innovation, new structures, and a carefully monitored interrelation of theory and profession.

#### 4 Developing the Tübingen School of Education

The Tübingen School of Education was developed in a period during which the University of Tübingen succeeded at attaining and defending the official status of excellence, in 2012 and 2019 respectively, within the federal and state governments' Excellence Initiative. In 2012, the university was successful with its future concept 'Research—Relevance—Responsibility'. The Tübingen School of Education identified itself with the motto of this concept at an early stage, adapted it for its mission statement, and was able to take on an active role in the university's application for the status of excellence in 2019, which was also successful then. This motto has since been implemented in manifold ways to the benefit of teacher education and continues to have a formative effect on the planning and execution of measures and projects. With the support of the university management and boards, the development of the Tübingen School of Education was enshrined in the university's structural and developmental plan. Since 2015, a plethora of measures have been carried out, of which only the most important are mentioned:

- ▶ Refurbishment and financing of an attractive and centrally located landmarked building in the heart of the university city for the administrative office
- ▶ Establishment of an advice center for students in teaching degree programs
- ▶ Establishment of a new committee structure with, *inter alia*, an Executive Board, an Advisory Board, a School Board, and a Teaching Board

- ▶ Financing of eighteen new professorships for teacher education, of which thirteen are subject didactic and five are educational science professorships
- ▶ Financing of eight new subject didactic council offices, especially in the major teaching subjects
- ▶ Establishment of seven conceptually developed areas of work (see graph 3 and 4)
- ▶ Establishment of an internal and external network in furtherance of effective and innovative teacher education

With these measures, the university management demonstrates a commitment to teacher education that is unmatched in the history of German teacher education. Within few years, the head office, formerly equipped with only one office at the previous center for teacher training, was expanded into a broadly oriented, differentiated, and high-performing institution.

The TüSE's mission statement emphasizes its identity and objectives. It consists of seven pillars:

1. Strengthening awareness of the importance of teachers for the future of our society. Teachers are required for multiple important tasks, which include qualifying future generations, promoting diversity and societal participation, working with digitalization challenges, and reducing inequality. The TüSE works towards preparing teachers to deal with these challenges professionally.
2. Conducting research on an international level and promoting knowledge transfer. The TüSE utilizes and supports a wide spectrum of research methods for covering topics like school, teacher education, and learning and teaching processes. Methods include empirical-quantitative, empirical-qualitative, theory-based, historical, and international-comparative approaches.
3. Providing versatile paths and tailored support for junior academics in the various fields of educational research.  
The systematic and individual support of junior academics is considered essential for advancing an innovative and sustainable research culture. It includes trainings in research methods, writing and presentation skills, networking inside the university, Germany-wide and worldwide.
4. Connecting academic research and practical experiences of pre-service and in-service teachers.  
The TüSE aspires to a nuanced and scholarly debate. It aims to satisfy the special requirements of teacher education programs and the teaching profession itself, and to bring about the systematic convergence of perspectives from different areas of

content knowledge, pedagogical content knowledge and educational sciences, with special consideration of theory-practice interrelations.

5. Supporting the development of professional competences and nuanced academic judgement.

TüSE puts teachers' professional competences in the spotlight and works intensely with definitions, characteristics, development, and the assessment of professional competences.

6. Guiding and supporting pre-service teachers, both systematically and individually. Counselling programs with a focus on professional biographical work and personal aspects are offered to students in teaching degree programs, combined with guidance and advising on organizational educational matters.

7. Creating a network for the best possible education of future teachers.

TüSE works towards building a continuously growing network of professionals involved with teacher education at the university and global level, including members from various educational, social, cultural, or economic institutions.

## 5 Institutional integration and committee structures

In the past, teacher education in Germany showed a lack of coordination between the subjects, which could not be improved by mere curricular changes, requiring institutional structures across faculty borders (Horstkemper, 2020). This challenge was solved at Tübingen University by creating the Tübingen School of Education as a central academic institution with a virtual structure, rather than a faculty. The new structure allows six faculties in all matters of teacher education to be connected. The TüSE collaborates closely and in multiple ways with these faculties and subject departments.

At the university level, all Schools of Education can now represent the needs and requests of teaching degree students in the universities' committees, functioning as engaged, informed, and determined cooperating partners within their universities. As Boettcher and Blasberg (2015) highlight, Schools of Education serve as institutions with which students in teaching degree programs can identify since the Schools serve as a counterpoint to the fragmented study experiences of students in teaching degree programs. The core innovation introduced by the TüSE is best described as providing a space where researchers as well as educational administration from all areas of teacher education at Tübingen University collaborate by discussing and developing shared academic or urgent organizational questions of teacher education.

Figures 1 and 2 show the faculties and institutions involved and their most important platforms within the Tübingen School of Education.

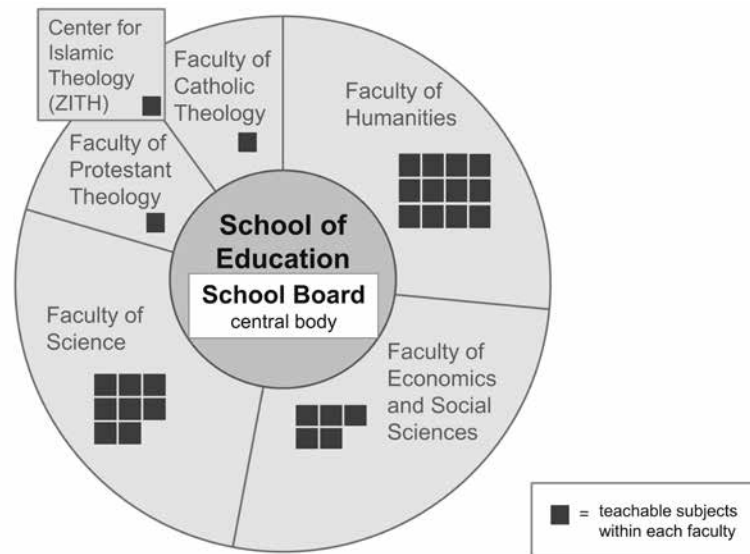

*Figure 1 TüSE as a virtual structure connects five faculties offering teacher education subjects.*

On the institutional level, TüSE is directly assigned as a central academic institution to the presidents' office and works on the basis of its individual statutes. Researchers and teaching staff who are involved in teacher education can request formal 'membership', thus becoming members of their own faculty and additionally of the TüSE. Figure 2 gives an overview on the TüSE's committee structure, which is briefly introduced in this text.

The committee structure is intended to substantially facilitate the integration and participation of all internal actors in teacher education in various formats and to allow them to have a lasting effect. This refers particularly to the integration of the teacher training faculties and subjects.

The central committee is the School Board, in which all organizations and domains involved in teacher education are represented by academic staff, students, doctoral students or regional schools. A formal link to the faculties is established here through elected representatives. All of the TüSE's major decisions and strategies are discussed, planned, and executed in the School Board. In addition to the elected representatives, interested colleagues can participate in the meetings in an advisory capacity and receive the minutes upon request, an option that is actively used. In this way, the circle of

persons involved can be extended without diminishing the School Board's status, which is binding and defined by the statute.

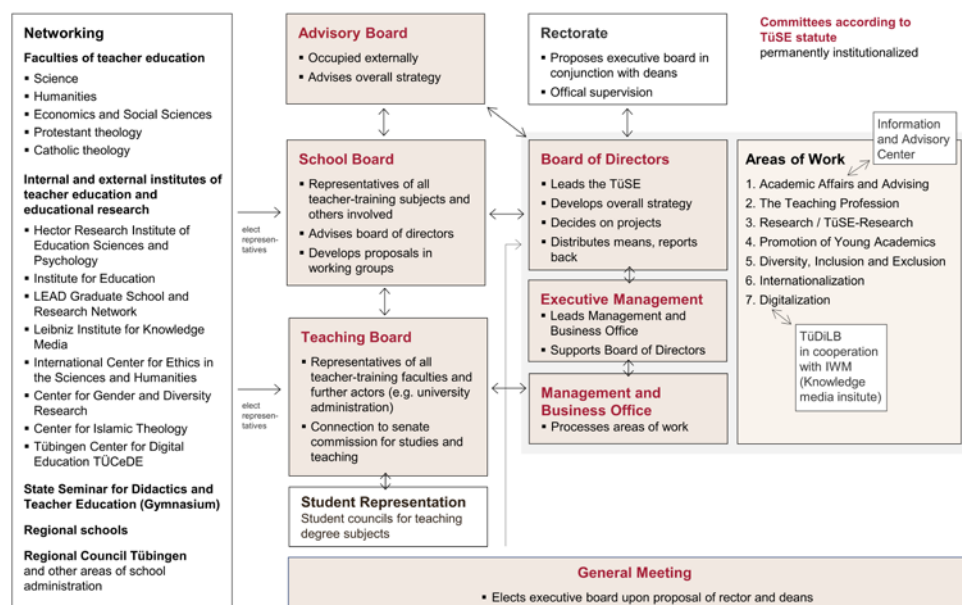

Figure 2 TüSE's organizational structure

The Advisory Board is comprised of external experts in the fields of educational science, didactics, economics, school administration, and charitable foundations. Other external Critical Friends are invited to the meetings for particular points on the agenda. The Advisory Board analyzes and discusses the basic situation and general development while in-depth discussions about individual work areas and projects also take place consistently. For example, the Advisory Board has discussed the structure of TüSE Research and made valuable suggestions.

On the Teaching Board, central issues of study and teaching in teacher education programs are discussed. Here, too, the decisive actors are designated by statute. On the whole, the committee structure has undoubtedly proven itself in the early years. The diverse participation and the integrative approach have led to a high level of intramural acceptance of the TüSE. Nevertheless, as a central academic organization its coordination effort is very high in general and in all fields, as there are always structurally cross-cutting tasks to be addressed and actors from different areas to be networked with and integrated.

## 6 Work areas

The Quality Initiative for Teacher Education is accompanied by a structural change in teacher education, which can be described precisely (Bohl & Beck, 2020): from a service unit for study and teaching to a central research institution. This change undoubtedly also applies to Tübingen and, as an essential focus, is unreservedly supported by all those involved in teacher education. Based on this fundamental alignment, the Tübingen School of Education has by now differentiated into seven areas of work (Table 2). Each area is equipped with a strategic plan, a conceptual orientation, personnel coverage, and specific research or development projects.

Areas of Work at ...	Core Activities
Academic Affairs, Advising and Assistance	<ul style="list-style-type: none"> <li>–development of study programs</li> <li>–innovations in teaching and learning</li> <li>–individualized advice on all study-related matters</li> </ul>
The Teaching Profession	<ul style="list-style-type: none"> <li>–variety of school internship options</li> <li>–projects and ongoing collaboration with regional schools</li> </ul>
Research	<ul style="list-style-type: none"> <li>–initiating and steering multiple third-party funded, interdisciplinary research projects in teacher education</li> </ul>
Graduate Program	<ul style="list-style-type: none"> <li>–supporting doctoral students with several measures</li> <li>–annual award program for excellent master's and doctoral theses</li> </ul>
Diversity, Inclusion and Exclusion	<ul style="list-style-type: none"> <li>–strategic approach to include, reflect on and implement inclusion in study programs</li> <li>–professional trainings for teachers increase awareness and competence</li> </ul>
Internationalization	<ul style="list-style-type: none"> <li>–establishing an international network in teacher education</li> <li>–developing international exchange programs for students and researchers</li> <li>–measures to support 'Internationalization at home'</li> </ul>
Digitalization	<ul style="list-style-type: none"> <li>–systematic approach to improve digital competences of students and teachers</li> <li>–several measures to implement digitalization in teacher education and in schools</li> </ul>

*Table 2 Areas of work at Tübingen School of Education*

The classic *area of work 1*, Academic Affairs and Advising, is dedicated to study and teaching, as well as to informing and advising students. Communication with students and their concerns is carried out especially through this work area. The former

student advisory service has developed into a broadly and flexibly oriented advisory center, in which students receive answers to questions about their studies, but also about uncertainties concerning their choice of profession. The advisory center is well-connected with other advisory offices and, if necessary, arranges further contacts.

In *area of work 2*, Teaching Profession, alternative internship opportunities are developed and offered. At the same time, networking with regional schools takes place here: for example, schools offer opportunities for work experience that go beyond the normal mandatory internships, such as in homework supervision for school students. In *areas of work 3*, Research, the TüSE's research is completely restructured (see below). This area has developed dynamically. Here the networking of researchers in Special Interest Groups as well as in targeted research initiatives takes place, for example to prepare applications in concert.

In *area of work 4*, Promotion of Young Academics, young researchers are systematically supported. The starting point of this support is the so-called initial interview, in which those involved together determine how the doctoral process can be facilitated. An essential feature of this work area is the systematic provision of training in research methodology. This meets a need that is often present when empirical research is carried out in subject didactics. Furthermore, prizes are awarded for excellent theses, and doctoral conventions are held within this work area.

Within *areas of work 5*, Inclusion, Diversity and Heterogeneity, this topic area is integrated into research, teaching, and advanced training. The basic approach is to reflect on inclusive and exclusive processes in society, school, and university. In doing this, a broad conceptual understanding is pre-supposed, meaning that it is not solely about students with special educational needs.

The development and realization of the TüSE's internationalization strategy is carried out in *area of work 6*, Internationalization. An international network of selected partner universities offering comparable structures of teacher education is established. In addition to international offers for students, research collaborations are developed. 'Internationalization at Home' is supported through intensive contact with foreign Schools of Education, regular summer schools and international work meetings.

Through *area of work 7*, Digitalization, the topic of digitalization is systematically developed and integrated into teacher education. For this purpose, several research and development projects are being executed, particularly the development of a digitalization center affiliated with the TüSE.

In the following section, the area of Research is described more closely. It clearly illustrates the quantum leap between the former Center for Teacher Education and the Tübingen School of Education today.

## 7 TüSE Research

From the outset, developing an interdisciplinary research structure was one of the TüSE's main objectives. The starting point for this was as follows: in the TüSE, eighteen teaching subjects received additional expertise to represent their didactic aspects through a professorship and/or an Academic Council. Add to this about seven professorships of educational science, as well as further specialist researchers or researchers from other organizations. The disciplinary, scientific-theoretical, and methodological background of the individual researchers is highly varied: roughly speaking, the research is theory-based, empirically quantitative, empirically qualitative, and internationally comparative. The TüSE has consciously supported this heterogeneous orientation from the beginning for several reasons. First of all, the objects of research – education, school, and teacher education – can only be appropriately grasped by varied approaches. Secondly, students of the teaching profession inevitably experience this diversity in their studies, which is why it must be addressed and reflected upon intensely. Thirdly, a clear premise from the outset was to “take along” as many researchers as possible and to integrate their respective expertise and research interests into the TüSE's work. Against this backdrop, the strategic decision of the TüSE in favor of only *one* research methodological direction, which might have been perceived from the outside as a sharper contouring, would at the same time have meant negating the expertise of numerous actors, who would certainly have been less motivated to participate in the TüSE's research.

The Tübingen School of Education is situated in an exceptionally strong research environment, not solely because of the university's success in the excellence strategy, but also because, in addition to the numerous subjects, there are several educational science institutions that are rich in tradition, internationally visible, and innovative: the Leibniz Institute for Knowledge Media, the Hector Research Institute of Education Sciences and Psychology, the Institute of Education, the International Center for Ethics in the Sciences and Humanities, and the newly founded Methods Center. The TüSE cooperates intensively with these institutions. In addition to joint research activities, representatives of these institutions can be found in the School Board.

The development of the TüSE's research structure is taking place in a period in which the national research discourse is characterized by some essential features: (1) Based on the PISA studies, a strong empirical quantitative line of research has developed, which also led to the founding of a new specialist society, the Society for Empirical Education Research. Slightly later than this development, empirical qualitative research has also expanded considerably and dominated the program of the German Educational Research Association. Based on this it was and remains a concern of the



TüSE to integrate these different research paradigms and bring them into a fruitful collaboration.

In the meantime, subject didactics have been able to develop into distinctly research-oriented disciplines, even if there are still large differences between the subjects: for example, the fields of mathematics and natural science profited significantly from the upswing in empirical quantitative research. Against this background, the TüSE aims to further strengthen subject didactic research and to merge it with educational science research in service of a win-win situation.

Over the last twenty years or so, research incentives through calls for proposals have been increased significantly. This is not only due to the greater engagement of the European Union, of the federal government or of the state government, which are increasingly advancing competitive proposal programs in the field of education, but also to the substantial increase in foundations in general, as well as the increase in foundations operating in the field of education (Dedering, 2013; Bundesverband Deutscher Stiftungen, 2019). The increasing number of calls for proposals forces academic institutions to adopt an application strategy. Particularly for an institution like the TüSE, which is wide-ranging thematically, one must continually ask whether one should respond to a call for proposals, and if so, in what way.

Despite the increasing calls for proposals from foundations and the government, there is a consensus in the scientific community that the funding models of the German Research Foundation (DFG) offer the highest reputation, in addition to individual funding and particularly to cooperative DFG-formats (e.g., Collaborative Research Centers, Research Units). Such formats are highly competitive and require long-term strategic planning in addition to excellent research, for example, in order to establish the requisite preliminary work and collaborations.

Based on this starting point, the TüSE has gradually worked out its research concept in recent years. In particular, the topic was included in the meetings of the Advisory Board and the School Board, where it was discussed intensively. Furthermore, a conference was held about the subject. After almost two years of preliminary work, a research strategy for the TüSE has been developed, which is concretized in three lines.

*Line 1*, “Cooperations related to calls for proposals”, offers a structuring of the approach for relevant calls for proposals. If there is a relevant call for proposals, it is examined first by the executive board and management, who inform the actors in question and then bring together possible collaboration partners to write the application. The application is then written by cross-sectional teams according to the respective content. Then the executive board and management of the TüSE usually ensure that the application is submitted in a formally correct way. This is the TüSE's response to

the increasing number of calls for proposals and ensures the involvement of the relevant actors.

Within *Line 2*, ‘Special Interest Groups’, researchers work on a common topic based on individual interests. Currently, colleagues from subject didactics, science and humanities subjects, and educational sciences, are conducting joint research in seven SIGs: (1) professionalism in the teaching profession; (2) relativity, normativity and orientation; (3) reconstructive subject didactic teaching research; (4) competence modelling and development; (5) digitalization in teacher education; (6) critical thinking and beyond: normative questions in teacher education today; (7) support of practice-oriented competence development in university teacher education. The establishment of the SIGs expresses the TüSE's claim to integrate the diverse thematic, methodological, and methodical accesses to Tübingen teacher education, school, and classroom research and, at the same time, to pool the expertise of the researchers. The establishment of a SIG is permitted by the School Board according to certain guidelines (e.g., the appointment of a spokesperson; the participation of at least two disciplines; regular meetings), and subsequently receives financial and structural support from the TüSE. The SIGs can be understood as a bottom-up strategy, because here it is primarily the interests of the researchers that led to the topics mentioned above. In this way, a strategy is consciously supported that does not necessarily lead to mainstream topics, but explicitly leaves room for new, innovative, and possibly hitherto neglected topics.

*Line 3* comprises all need- and resource-related measures and activities. Here, thematical needs are identified by the TüSE's executive board and management, research collaborations are initiated, and, if resources are available, also supported. This is done, for example, through internal announcements of doctoral positions that strengthen a specific goal of the TüSE in terms of their content (e.g., strengthening collaborations of subject didactics and educational sciences). As a rule, the positions are assigned by means of double-blind peer-review procedures involving external experts. With these three lines, which were developed through a transparent, cooperative, and discursive process, the TüSE is equipped on the one hand to respond to external calls for proposals, and, on the other hand, to advance control measures and to integrate the interests and expertise of those involved. Even before the introduction of this binding strategy, the TüSE was very successful in attracting and conducting research projects since its foundation in 2015. Since then, sixteen third-party funded projects with a total volume of 19.2 million euros have been acquired. Only those projects are listed that were acquired ‘centrally’ under the leading participation or leading management of the TüSE board of directors.

At the moment, the next step of the long-term strategy is being tackled: to focus on difficult long-term DFG research formats, doctoral positions are being allocated to

SIGs. The internal announcement of these doctoral positions contains the requirement to submit a long-term plan for achieving a challenging research format.

## **8 Institutions in comparison: Wits School of Education and Tübingen School of Education**

The institutional situation of the Wits School of Education is similar in many respects, even if the historical development and socio-cultural context differ significantly. For this reason, some parallels between them, outlined below, will be surprising.

### **8.1 Institutional localization of teacher education / Schools of Education**

Like the TüSE, the WSoE is a young institution that has only in recent years identified research as a central theme and developed a research structure. The WSoE is a School within the Faculty of Social Sciences, subdivided into subject areas that correspond to the teaching subjects offered there. The WSoE thus has its subject-specific (subject didactical and educational scientific) expertise ‘in house’.

Moving Schools of Education into Faculties of Social Sciences or Faculties of Education is not very common in Germany, but can also be found, for example, at the University of Hamburg. By establishing the TüSE, the University of Tübingen created a central academic institution, spanning across the faculties involved in teacher education.

The structure serves the explicit goal that subject didactics and educational sciences remain integrated in each faculty, but also that they establish and develop a new focus within their subject, including a possibly new or additional research method. Actors in teacher education are members of their faculty and field of work, and at the same time, members of the TüSE. This double membership enables a broader range of options: joint applications, research, and networking are possible beyond disciplinary boundaries. On the other hand, double membership also requires double commitment. Making this commitment visible and remunerating it on an intra-university level is a further goal of the TüSE.

### **8.2 Extension of the functional range through dedicated research orientation**

Both schools are motivated by the desire for first-class, research-based, and efficiently structured teacher education. Furthermore, Schools of Education are internally and externally driven by questions of reputation enhancement. In the coming years,

it will be important to demonstrate that the development of teacher education from one mold, intensive commitment to didactic and educational research, as well as a stringent interrelation of theory and practice can offset those weaknesses of teacher education that have been criticized for decades, and thus raise it to a new level. This should be surveyed and analyzed by empirical research in the coming years.

With their focus on intramural reputation, both Schools of Education are struggling with the familiar situation that teacher education has not traditionally been a high priority. It is the task of the Schools of Education to demonstrate that the new structures clearly go beyond the traditionally narrow focus on questions of study and teaching. Both institutions see profound research as the foundation for a future-oriented teacher education and focus on PK, CK and PCK research. Furthermore, they work with empirical and theoretical research paradigms, and historically and internationally comparative perspectives.

Is it not by coincidence, therefore, that the two Schools share a special similarity in the importance given to research and in the almost identical research structure. Both schools aim at interdisciplinary, thematically focused research alliances (WSoE: Research Thrusts; TüSE: Special Interest Groups), supported by almost all academics involved in teacher education. In both schools, the seven research alliances happen to be defined in the same way. However, the topics vary, and while the WSoE's thrusts are defined more as basic research fields (e.g., literacy, numeracy, teaching, and learning), the TüSE's SIGs cover narrow and more specific topics, in which a narrowly-defined research aspect is addressed (e.g., relativity and normativity; competence modelling and competence development; reconstructive subject-didactic research). With this transverse research structure, both schools are trying to strengthen internal cooperation and increase external visibility through research outputs. This is intended to also strengthen external reputation, which is achieved through highly competitive performance measurements and rankings, with high-ranking publications in peer-reviewed journals being the measure of all things.

In Tübingen, this standard is pursued in a similar way, though measured less strictly by publications; rather, third-party funding and high-ranking research formats such as DFG grants are equally important. While both schools focus their strategies on the 'fulfilment' of these standards, a critical and relativizing view of this competitive orientation is nevertheless evident. In the framework of the TüSE, this can be seen in the SIGs' thematic orientation, which deliberately promotes topics outside the mainstream as a bottom-up strategy. The WSoE criticizes that, while the framework conditions for research are set by such benchmarks, this does not mean that the needs of the School are covered.

### 8.3 Targeted institutional development work within the framework of seven areas of work

Because of its fragmented structure, teacher education received little attention at the institutional level before 2015. Through the seven work areas of the TüSE, concepts and structures for study and teaching, research, the promotion of young academics, the teaching profession, inclusion and internationalization are developed. Strategic projects and new approaches are tested, adapted and, if successful, established. In this way, modern and innovative formats for students, researchers and lecturers can be systematically developed.

## 9 Concluding remarks

The aim of this contribution was to give an overview over the structure and institutional situation of the TüSE. To highlight it, the TüSE's institutional situation was compared with that of the WSoE. The various topics related to it could only be touched upon and analyzed roughly in the context of this contribution. With view to research, the central challenge for the TüSE may be to achieve top-class research formats in the medium to long term, based on the structure that has now been laid down in the three lines mentioned and particularly based on the established SIGs. With view to the institutional situation, it is still important to identify the cross-cutting topics and tasks more clearly and to solve them. Interfaces and co-operations with other subjects and faculties are particularly important in this, for example when it comes to introducing systematic improvements of teacher education that require measures beyond individual subjects. Only a few years ago, such challenges would have exceeded any target category. The increased creative possibilities of the TüSE show that it now faces such challenges. For the time being at least the transformation of a small center for teacher education into a central academic institution within a few years has found success.

### Literature

Blömeke, S. (2009). Lehrerausbildung in Deutschland [Teacher training in Germany]. *PÄD-Forum: Unterrichten erziehen*, 37/28 (1), 5–8.

BMBF (2016). *Neue Wege in der Lehrerbildung: Die Qualitätsoffensive Lehrerbildung* [New ways in teacher education: The quality initiative in teacher education]. Bundesministerium für Bildung und Forschung. [https://www.qualitaetsoffensive-lehrerbildung.de/files/Neue\\_Wege\\_in\\_der\\_Lehrerbildung.pdf](https://www.qualitaetsoffensive-lehrerbildung.de/files/Neue_Wege_in_der_Lehrerbildung.pdf) [12.07.2020].

Böttcher, W., & Blasberg, S. (2015). *Strategisch aufgestellt und professionell organisiert? Eine explorative Studie zu Strukturen und Status der Lehrerbildung* [Strategically positioned and professionally organized? An explorative study on structures and

status of teacher education]. Deutsche Telekom Stiftung. <https://www.wissensatlas-bildung.de/publikation/strategisch-aufgestellt-und-professionell-organisiert-eine-explorative-studie-zu-strukturen-und-sta/>.

Bohl, T./Beck, N. (2020). Aktuelle Entwicklungen in der institutionalisierten Lehrerinnen- und Lehrerbildung [Current developments in institutionalized teacher education]. In C. Cramer, J. König, M. Rothland & S. Blömeke (Eds.), *Handbuch Lehrerbildung*. 66–75. Klinkhardt / Utb.

Bundesverband Deutscher Stiftungen (2019). *Zahlen und Daten* [Numbers and data]. <https://www.stiftungen.org/stiftungen/zahlen-und-daten.html> [25.07.2021].

Dedering, K. (2013). Staat, Stiftungen und Schulentwicklungsberater. Zur Handlungskoordination alter und neuer Akteure im Bildungsbereich [State, foundations and school development consultants. On the coordination of old and new actors in the education sector]. *Bildung und Erziehung*, 3, 331–348.

KMK (2004). *Standards für die Lehrerbildung: Bildungswissenschaften. Kultusministerkonferenz der Länder* [Standards for teacher education: Educational sciences. The federal states' conference of ministers of education].



## Chapter 5

### Inclusive Education and Diversity in South Africa and Germany – Concepts, Policies, and Historical-Political Paradoxes

Douglas Andrews, Jonas Bischof, Marcus Emmerich and Ruksana Osman

*In this book chapter, the authors will focus on the historical development of inclusive teaching in both the German and South African socio-political contexts. The authors will first summarize the historical context of inclusive teaching with regard to education reform in South Africa and Germany. This study was conducted by scholars from the University of the Witwatersrand in Johannesburg, South Africa and the University of Tübingen in Tübingen, Germany. In this chapter, the authors draw on studies in South Africa and Germany to foreground how discussions on the complex cultural, social, political, and historical sediments have influenced the traction of inclusive education provision in both countries and shaped contemporary school contexts. The authors argue that politico-historical contexts are of critical importance to better understand how the ideas of inclusive education and teaching diversity are expressed and acted upon in unique contemporary school contexts. These findings call for researchers to consider the historical roots that have constrained or enabled inclusive education provision in their country.*

<http://dx.doi.org/10.15496/publikation-76382>





## **Part I: The South African context**

### **1 Introduction**

Globally, classrooms are complex spaces in school systems that are guided by the organizational structures and national traditions of the country in which they are located. This is no different in South Africa, where school systems and pre-service teacher education providers are directly influenced by national policies, emerging from historically shaped contexts and traditional influences. These historical contexts that inform policy and directives can be attributed, in part, to political, geopolitical, traditional, and social influences. In this chapter, the authors describe and analyze the socio-political situation and policy formation processes regarding inclusive education and diversity in the South African context, outlining existing perspectives on learners and explaining former and existing structures, policy changes, and their effects. The authors consider the argument that there is a mismatch between policy aspiration for inclusive education in South Africa and deep-seated beliefs about diversity and difference that are difficult to shift, especially if teacher education is, in some higher learning institutions, pursuing an approach that reinforces a medicalized view of divergent learner behavior.

### **2 The historical context of education policy under Apartheid legislation**

In 1948, the Afrikaner National Party came to power in South Africa (Chisholm, 2012). Between 1948 and 1990, the ruling National Party instituted policies of racial segregation under Apartheid laws. Historically, education policies and directives under the Apartheid State instituted the segregation of children according to their race and disabilities. For example, in 1953, the Apartheid government passed the Bantu Education Act into law. This act formalized unequal education for black South Africans, who were to be educated to the level of manual labor only (Kallaway, 1984). As for education, disabled school students were seen as different from the norm and thus also incapable of benefitting from mainstream education. Therefore, it was thought that they should instead be taught in special needs schools that accommodate their disabilities. There was a preoccupation with disability categories and a medicalized approach during the Apartheid years in South Africa. Historically, the medicalized approach relied on the use of classificatory systems for perceived learning limitations in children, “mainly based on medical or psychological categories—for example, ‘sensory impairments’ or ‘intellectual difficulties’” (Terzi, 2005, p. 446).

There were two chronological phases of segregating learners with diverse learning abilities. The first was to separate the ‘normal’ child from the handicapped child. The second was to distinguish among the handicaps. In the first phase, learners were distinguished according to whether they were ‘handicapped’ or ‘normal’. Handicapped children were considered as belonging to a different category of children. The Act of 1948 (Section 1) defines the “handicapped child” as one who deviates to such an extent from the majority of children in body, mind or behavior that (a) he cannot derive sufficient benefit from the instruction normally received in the ordinary course of education, (b) he requires special education to facilitate his adaptation to the community, or (c) he should not attend an ordinary class in an ordinary school, because such attendance may be harmful to himself or to the other pupils in the class.

Act 41 of 1967, which refers to white children only, defines a ‘handicapped child’ as one “belonging to a category of children” (RSA, 1967a, Section 1 (xiv)) described in a schedule of eight possible handicaps. The De Lange Report (1981) refers to 21 categories of ‘handicapped child’ and the Stander Report of 1987 lists 11 categories of “impairment”. Other classification categories had traction during the Apartheid era. The Murray Report of 1969 distinguished between (white) children who had slight difficulties and who could, with remedial assistance, function in the mainstream; children with moderate difficulties who would require temporary, but full-time remedial assistance; and children with severe disabilities who required special education (Partington, 1991). This three-fold categorization was further developed by the De Lange Report of 1981, which identified “scholastically impaired pupils” in mainstream education, “handicapped pupils” in special education, and “highly gifted pupils” (p. 29). Ten years later, du Toit (1991) found it necessary to subdivide children's problems into those relating to development, learning, and behavior. A further distinction was made between what were deemed “restraints” and “handicaps”. Restraints, du Toit maintained, “develop when certain factors or circumstances extrinsic to the child... cause him (sic) not to actualize his possibilities optimally” (p. 26). Handicaps, by contrast, referred to “an identifiable deficiency of the child's given potential” (p. 26) and were synonymous with disability. When considering the institutionalized categorization of people on racial lines under Apartheid, which subsequently informed educational policy directives for the teaching of children with special needs, the legislative ideas of inclusive education and diversity in the South African context acquire a special meaning. This special meaning is unique in South Africa's apartheid history, where every policy intervention in the aftermath of this dark period had to ensure that a human rights ethos prevailed. This was especially challenging as the education doctrine enforced by the Apartheid regime focused on control, which impacted pedago-

gical thinking, teaching practices in classrooms, and attitudes towards learners with diverse learning needs (Naicker, 2007).

This historical education policy, formulated and enacted by the Apartheid state, raises some interesting questions, notably concerning whether newly promulgated policies in the post-Apartheid era were able to change education spaces from environments informed by the ideas of the medical model, racial segregation, and special needs thinking, into teaching and learning spaces accepting of learner diversity. It is worth noting that a defining characteristic of disability studies in both the United Kingdom and in the US “was the rejection of the medical model of disability and the advocacy of full inclusion of disabled people in all aspects of society” (Connor et al, 2008, p. 443). This rejection demonstrated a shared dissatisfaction with the institutional practices aligned with special needs education, informed by the medical model, which resulted in what the authors called “detrimental and indefensible instructional practices” that promoted the use “of damaging labels and deficit-driven, medicalized conceptualizations of disability that undeniably contradicted the views and life experiences of many disabled people” (p. 445). The history of the Apartheid legacy, with its policies of racial segregation and advocacy for special needs teaching, has ‘cast a long shadow’ over newer initiatives that advocate for basic human rights and education for all. These ‘historical sediments’ have slowed the traction of inclusive education over the course of the post-Apartheid years.

### **3 The South African context in the immediate post-Apartheid period**

The policies that directed the segregation of children according to their disabilities changed after the end of legalized apartheid. This occurred during the transition period between the 4<sup>th</sup> of May 1990 and the 27<sup>th</sup> of April 1994, when the nation changed from a racist, authoritarian state into a democratic society. As a result of the political changes in the country, there was a discernible shift in thinking from the ideas associated with segregated education and division to the ideas of inclusive education. This was in line with a shift from a racially segregated society to an inclusive society based on the principles of human rights and dignity. This shift in thinking aligned with newly established constitutional laws set in place on the 4<sup>th</sup> of December 1996. These constitutional laws were introduced to govern and transform the education system. This transformation was supposed to occur in accordance with the idea of an inclusive education system that recognizes the right of all children to an equitable education. There is evidence that indicates a foregrounding of links between the newly promulgated national constitution, the principles of human rights, and inclusivity within

education policy development (Lomofsky & Lazarus, 2001). Because of this, a change in legislation and policy was necessary for shifting the values of society from one characterized by segregation and marginalization, towards one based on the values of inclusion and democracy. Engelbrecht (2006) outlines how educational change in the direction of inclusive education in the South African context was not just another teaching or operational strategy, but rather a change that aimed to contribute to a democratic society, and that this could only be achieved through fundamental reform. To achieve educational change, various educational policy documents and directives provided a roadmap for how inclusive education in South Africa was to be actualized. The most influential document in South Africa, created with this goal in mind, was the National White Paper 6: Special Needs Education; Building an Inclusive Education and Training System (Department of Education (DoE, now DBE), 2001) (WP6). This document outlined a national strategy that set out to achieve an inclusive education system, focusing on addressing and accommodating learners who experience various barriers to learning (Engelbrecht, Nel, Nel & Tlale, 2015). Two stated goals of the WP6 policy are, firstly, to systematically move away from using segregation according to categories of disabilities as an organizing principle for institutions, and secondly, to introduce strategies and interventions that will help educators cope with a diversity of learning and teaching needs to ensure that transitory learning difficulties are ameliorated (National White Paper 6, p. 10).

#### **4 The impact of the Apartheid legacy on education reform in South Africa**

It was envisaged that a process of policy reform would create a sense of hope for learners vulnerable to marginalization and exclusion (Muthukrishna et al., 2002). However, despite the attention given to policy reform, it became evident that these reforms had failed to gain the traction anticipated. Christie (2006, p. 373) explains that “by the mid-1990s, education theorists and researchers had begun to puzzle about what had happened to the envisaged policy shifts after the establishment of the new Government of National Unity (GNU) in 1994.”

##### **4.1 Lack of traction of the ideas of inclusive education as a result of ingrained ideas of segregation**

One reason for this lack of traction was that the ingrained way of thinking about the teaching of learners with different needs, under the education policies of the

Apartheid state, cast a long shadow on the implementation of inclusive education in South Africa. The ideas associated with the medical model and with racial segregation are ingrained in the thinking of many people who had and still have influence in education. Engelbrecht (2006, p. 261), who did research into inclusive education implementation in a South African school, showed that “enforcing control through policy change at a macro level cannot change human behavior, values, and attitudes.”

Conceptualizing the challenges associated with implementing inclusive education strategies in South African schools requires the history of the radicalized ideas of special education that informed policy and action during the apartheid years to be understood. These include a history of inequality and injustice for the majority of the population and the “theoretical frameworks within which ‘special needs education’ and ‘inclusive education’ have been located” (Engelbrecht, 2006, p. 254). Furthermore, South Africa continues to be a country characterized by significant wealth disparity. A minority of schools are well-resourced and progressive, while the majority of schools, particularly in rural areas, exist in poverty and are therefore severely under-resourced. Engelbrecht (2006, p. 255) explains how “huge disparities still exist between former advantaged schools for white children and formerly disadvantaged schools, especially those in rural areas where poverty, in all its manifestations, can be singled out as the most important characteristic of the communities in which these schools are situated”.

#### 4.2 Political compromises as a constraint to the traction of inclusive education policies

State policies for education in the post-Apartheid era were characterized by contradictions. One reason for this was that the democratic and non-racial state had to make compromises with members of the old order, leading to a re-racialization of the state (Soudien & Sayed, 2004). These compromises to policy change were a result of the post-Apartheid state being bound up with the various political negotiations and compromises between the National Party that governed Apartheid South Africa and Nelson Mandela's African National Congress, which together formed, initially, a coalition government. What transpired was that education became a “prime site through which the rearticulated racial state could be observed” (Soudien & Sayed, 2004, p. 101). These compromises came at a time when trying to build social cohesion was a national priority. It is argued that perhaps policymakers were too accommodating of divergent interests in an attempt to forge a future in which everyone could feel inves-

ted. The result, however, is that in South Africa, there exist contradictory policies, with unintended consequences.

Within the new policies created by this hybrid state, there were hidden legal provisions and formulations that promoted subsequent racial practices, which came into existence as a direct result of the ambiguity of various policies' texts. For example, the general direction of the education policy embodied in the South African Schools Act of 1996 (SASA), which aimed to provide a free, compulsory, and equal education for all learners, contained exclusionary possibilities. Central to this was the policy decision in the SASA (1996), which allowed for decentralization of authority in school administration and governance away from the state and the devolution of this authority to the management organs of schools, which included the schools' governing bodies. Although this policy decision on the provision of schooling can be seen as inclusionary, and legal provisions had the best intentions of deepening democracy by promoting freedom of choice and participation, this decision lent itself to exclusionary actions (Soudien & Sayed, 2004). The manner in which the policy decision to decentralize education authority came into effect gave little cognizance to racially and economically defined communities that could be excluded based on physical geography. This is relevant to the post-Apartheid landscape in South Africa where, although the racist laws of segregation were abolished, people still lived in communities that were physically separated along economic and racial lines. Because of this, the policies of decentralization only served to preserve the privilege of schools that sought to control which children to include and which to exclude. In practice, schools could determine their access and admission policies, which perpetuated continued segregation and discrimination of learners from accessing equitable education opportunities in their communities. Schools in South Africa continue to manipulate these policy directives to decide which children should or should not be allowed entry to a given school.

Decentralized structures led to disadvantages for speakers with native languages other than English, reflecting some school boards' monolingual tendencies and disregarding even the South African constitution (Soudien & Sayed, 2004). This flaw led to discriminatory practices, such as the decision of some school boards to teach in English only. At the schools in question, a majority of learners were not native English speakers. Little effort was made to incorporate the children's native languages in an affirming way. To give this context, the South African constitution of 1996 recognizes eleven national languages, with no individual language having superiority or privilege over another. However, these policy-driven actions, which enabled the decentralization of educational authority, were applied to create non-inclusive educational structures.

### 4.3 Conceptualizations of diversity and inclusive education in the South African context

From a policy perspective, inclusive education in South Africa is seen as a systematic response to those learners who have been disadvantaged, or who are still disadvantaged, in terms of educational provision (RSA, 2015). The concept of diversity has a very specific meaning in South Africa as a direct result of Apartheid. Recognizing the “notion of diversity” indicates recognizing different races and cultures (Carrim, 2018, p. 154). With regards to the conceptualization of learner diversity in the South African context, from a legislative perspective, the White Paper 6 (Department of Education, 2001) acknowledges and respects learner diversity in the form of ethnicity, language, class, gender, disability, or HIV status.

However, the conceptualizations of diversity and inclusive education in the South African context cannot be separated. Sapon-Shevin (2013, p. 58) explains that children differ in many ways “and that to think about education that is inclusive and responsive to one set of differences (called disabilities) and to ignore differences of race, ethnicity, gender, sexuality, language, religion, and class doesn't create an educational system that is truly inclusive of all.” Policies attest that inclusive education is about including a range of identities vulnerable to exclusion and not just issues related to learning differences. In the Global Education Monitoring Report (GEMR report 2020, p. 4), it is explained how “inclusive education has taken on a broader meaning, encompassing all learners and focusing on policies that make some groups vulnerable to exclusion from education.” It is further explained in the GEMR Report that regardless of group, the mechanisms of exclusion are common, and that there needs to be a focus on covering all mechanisms that expose children, youth, and adults to exclusion risks, while maintaining a special focus on people with disabilities. In the South African context, one cannot consider the idea of diversity in isolation from that of identity, where “dealing with the issue of diversity is always closely linked to individuals experiencing their own identity as ‘being different or not’ in a particular context” (Holck, Muhr & Villeseche, 2016, p. 2).

In light of South Africa's history of institutionalized racism, segregation, and the medical model of learner difference, one argument in support of inclusive education aligned with the broader concept of diversity was that society deemed any exclusionary practices in schools to be morally and constitutionally unacceptable (Winter & O'Raw, 2010, p. 10). It is argued that exclusion, in any form, may have damaging effects on individuals and groups within society. Because of this, education provision in the South African context must endeavor to ensure that no group of people is favo-

red by teaching and learning in schools (Andrews, Walton & Osman, 2019). An inclusive school in South Africa needs to consider a diverse range of learning needs in the classroom environment. It must also account for the diverse socio-economic circumstances affecting different learners and how this might impact their ability to participate on an equal footing with others in the classroom and school environment. To achieve this goal, some policies and directives explain the expected role and function of teachers in inclusive classrooms. These directives aim to operationalize the practice of inclusive teaching, informed by the need to accommodate greater diversity. The South African Policy on Screening, Identification, Assessment, and Support (SIAS) (2014) outlines the role of teachers in schools. The SIAS policy is the first in South Africa since the ratification by the Cabinet of the Convention on the Rights of Persons with Disability (2007) to provide direction on how students are to be included in schools, rather than rejected because of a disability. The organizing principle behind SIAS is that every learner has the right to receive a high-quality basic education, support within his or her local community and accommodation in an inclusive classroom. These reflections show the interconnectedness between the concept of diversity, identity, and the ideas of inclusive education within a South African context. This is specifically in relation to past histories under Apartheid, which enforced racial discrimination and categorization of learners according to a medicalized model. This resulted in the segregation of children into categories that defined them as 'normal' or 'with deficit', which subsequently led to separate education provision of mainstream schools and special needs schools. Carrim (2003, p. 20) argues that inclusion is not about the integration or the "assimilation or accommodation" of people with disability "within existing socio-economic conditions or relations," or about making disabled people feel as normal as possible, but rather about the transformation of society regarding its values, which were aimed at eradicating exclusion and racial discrimination. To address extreme inequality and oppression, the alienation of many vulnerable learners from receiving an equitable education in South Africa has to be understood through the intersectionality of the concept of diversity and that of inclusive education.

#### 4.4 Pre-service teacher education for inclusive teaching in South African universities

Education in South Africa under Apartheid governance reflected society's political philosophy. Its educational policies were based on categorical segregation. This segregation of people, applied to race, had also been applied to the educational categories found in the field of special education. Under special education provision, children in



all racial groups were classified according to their handicaps (Skuy & Partington, 1990). The radicalized nature of special education was not only reflected in the segregation of children in *general* or *special* schools according to racial groupings and educational categories, but also in the way pre-service teachers were educated at university. Amongst South Africa's twenty teacher training providers, which at the time consisted of universities and teacher training colleges, fourteen of them offered specialized diplomas and degrees that addressed special education. In these degree and diploma courses, teachers were trained to teach at special schools, where they would address, amongst others, categorized learning disabilities, mental retardation, and visual handicaps (Skuy & Partington, 1990). The radicalized nature of special education not only impacted children, who were categorized either as 'normal' or as different and thus 'handicapped', but also how teachers were trained to respond to learner difference during the Apartheid era. This way of thinking has been difficult to overcome even after it.

Despite the policy directives of the WP6, calling for inclusive teaching to be practiced in South African schools, South African universities continued to be influenced by medical model schools of thought in the development of their pre-service teacher education courses. Nel, Tlale, Engelbrecht and Nel (2016) found that pre-service teacher education at universities leaned towards a medical/individual model, and Donohue and Bornman (2014; 2015) describe how teachers in South Africa were trained to teach either general education or special education, with the result that teacher training institutions qualified many teachers who lack the skills to teach learners with disabilities. What these scholars highlight is how the non-alignment of teacher education programs for inclusive education at South African universities has constrained the traction of inclusive teaching.

Furthermore, there are issues with the way inclusive education is conceptualized and taught at individual universities. There is a need to interrogate the theoretical and conceptual underpinnings of what constitutes inclusive education curricula at South African universities. Within universities in South Africa, presentations of information in pre-service teacher education continue to conflict with each other. For example, there is a conflict between whether inclusive education should be integrated into the teacher training curriculum or whether it should be a stand-alone course. There is also disagreement among pre-service teacher education providers as to whether inclusive education should be informed by teachers' needs, knowledge based on policy, or knowledge based on authority in the field. These competing differences reflect the various theoretical and ideological views on teacher education of the many teacher education providers in the country (Walton & Rusznyak, 2017).

Walton and Rusznyak (2017) state that “initial teacher education for diverse students and inclusive classrooms would be strengthened by a more critical appraisal of the construction of courses in inclusive education.” It is suggested that such an appraisal of the course materials “has the potential to promote a rigorous and conceptually coherent approach to student diversity and inclusive teaching in initial teacher education” (Walton & Rusznyak, 2017, p. 238).

Finally, teacher education in South Africa needs to consider the intersectionality of diversity issues, which include gender, race, learning differences, language, and class. To achieve this objective, teacher education needs to take a “nuanced and sophisticated approach to power, privilege, difference, and oppression that engages multiple, imbricated axes of oppression and the way these play out in school contexts” (Reygan, Walton & Osman, 2018, p. 17). Very few pre-service teacher education programs in South Africa prepare teachers for a deeper engagement with issues of oppression and how it manifests within the classroom and broader society. Scholars note that “the interplay of multiple axes of oppression in terms of material, psychological and developmental consequences constitute complex terrain which requires sophisticated analysis” (Reygan, Walton & Osman, 2018, p. 10). What this tells us is that teacher education for inclusive education remains a critical focal point for the traction of inclusive teaching in South Africa.

## 5 Discussion

That inclusive education in South Africa is inexplicitly linked to the country's unique politico- historical context becomes clear in this discussion. The findings show how the lack of traction for the ideas of inclusive teaching in South Africa can be directly attributed to a catalog of factors. One of these is the deep-seated ideas of a medical-model way of thinking about disability and diversity, which promote ideas of segregation, both along racial lines and according to perceptions of what distinguishes a ‘normal’ learner from a ‘handicapped’ learner. Secondly, early policies for education provision in the post-Apartheid era were inextricably linked to political compromises that allowed for the ideas of racial segregation and the medical model to continue having an influence on teaching and learning. Thirdly, historically originating economical inequalities and segregated geographical distributions of people resulted in an uneven distribution of resources to schools, notably to those schools in rural areas. This was exasperated by policies that decentralized education authority. Finally, a lack of alignment between and within education providers for pre-service teachers resulted

in many institutions of higher learning continuing to advocate for the ideas of the medical model to categorize learner deficits. This is because of teacher educator program developers failing to conduct a critical appraisal of their course materials to address the severe socioeconomic disparities and learning differences that newly qualified teachers will face in the workplace.

Considering the 'sediments' of South Africa's unique politico-historical past and the complexity of the circumstances in contemporary school contexts, it is important to reflect on how the dark legacy of Apartheid could influence inclusive teaching practices in the future. There are no clear answers, and critical conversations need to continue in K-12 schools and institutions of higher education to challenge entrenched biases. In particular, the way we think about the way teachers respond to inclusive practices when teaching diverse learners must be challenged. Furthermore, there needs to be a continual engagement with African knowledge, as adopting the ideas of inclusive education hardly recognizes the history of colonialism and underdevelopment in countries like South Africa (Abdulrahman, et al., 2021).

## **Part two: The German context**

### **6 Introduction**

In this section, we analyze the concepts of diversity and inclusive education within the unique historical context of the German schooling system. In a similar way to the South African study, we reveal how the organizationally differentiated structure of schools in Germany generate a pattern of disparities and disadvantages primarily affecting students from poor and/or migrant families, as well as students classified as having special educational needs (SEN). As was seen in the South African study, recent policies implemented by the German state also aimed to implement inclusive education programs. We examine how this was put into effect against the backdrop of the German historical and political environment. We also explore whether these policies were able to change the education systems structure or vice versa, whether the German 'grammar of schooling' changed and changes the purposes and genuine concept of inclusive education.

The federal structure of the German welfare state in general, and in particular the political autonomy of the sixteen German states in school governance, can easily be identified as major causes for the variety of inclusive schooling concepts and policies. Moreover, these factors still have an impact on the curricula of pre-service teacher

education as the last link in the educational policy chain: the single states design the curricula to meet the requirements of their (more or less) differentiated school system. In Germany, ideas of diversity and inclusion meet an organizationally hierarchical and highly socially selective school system. These ideas appear as answers given to the education system from outside; it still seeks the appropriate questions from within. To what extent these concepts are capable of building a basis for reforming the German school system will be discussed in this part.

## **7 The historical context: nation-building, school organization and educational inequality**

During the 19<sup>th</sup> century, the implementation of public schooling was a crucial part of nation-building in Europe. One main purpose was the cultural homogenization of an ‘imagined’ national community (Anderson, 1983) that was, especially in Germany, ‘diverse’ in terms of religion, language and cultural heritage (Wenning, 1996). Organizing a compulsory education system that includes every inhabitant of a defined age constituted a solution for two structural problems: enabling cultural nation-building and qualifying the working class in order to meet the requirements of industrialization. Since school systems function as ‘historical machines’ guided by organizational routines and national traditions, attempts to structurally reform these systems were less likely to be successful, but rather reproductions of institutionalized organizational forms, cultural norms, and routinized professional practices. In Germany, the school system is characterized by an organizational differentiation of school types. This structure generates a typical pattern of disparities and disadvantages, primarily affecting pupils from poor and/or migrant families (Autorengruppe, 2018). After a four-year primary school, the system allocates the cohort to a secondary school system consisting of two to five (depending on the state) separated school types. The organizationally differentiated tracks through compulsory education finally lead to unequal exit exams, which in turn provide unequal transition opportunities. Parallel to this regular (compulsory) system, the German welfare state installed a separated school system and a specialized profession for Special Educational Needs in the early 20<sup>th</sup> century (Kastl, 2017), both of which still exist. To understand Germany’s ‘special path’ in policymaking and the paradoxes of inclusive education structures, knowledge of this historical and institutional background is required.

## 8 Reflecting or reproducing constructions of difference?

### 'Diversity' as educational concept

Referring to the concept of diversity is a rather recent phenomenon in German educational science and policymaking. The idea that schools encounter a 'diverse' pupil body now competes with former leading concepts such as 'cultural difference' or 'heterogeneity' (Lutz & Wenning, 2001). Like these alternatives, the concept of diversity has the function of constructing social reality for educational purposes (Emmerich & Hormel, 2013). In contrast to the former approaches, however, the term 'diversity' denotes a normative perspective that demands equity, full participation and anti-discrimination (Hormel & Scherr, 2004). An early example of a diversity education concept, Prenzel's (1993/2006) 'Pedagogy of Diversity' (orig. "Pädagogik der Vielfalt"), was influenced by women's-, anti-racism- and disability-movements. Prenzel sought to integrate the corresponding 'political pedagogies' that emerged in the 1980s (feminist, inter-cultural and integrative education). By conceptualizing 'diversity' as a generalized educational approach, Prenzel programmatically aimed to realize full social participation through education.

However, regarding the German educational discourse, cultural aspects of the diversity concept are emphasized, while societal inequalities indicated by categories such as class remain systematically neglected. Due to criticism of 'intercultural pedagogy', an approach that has been dominant and curricularly implemented in Germany since the mid-1980s, this culturalistic interpretation of diversity is historically plausible. As an educational program, interculturality is based on the political concept of multiculturalism and the idea that society itself is constituted by different ethnic groups. But multiculturalism does not match the traditional self-description of German society as being culturally homogeneous. Moreover, the term 'ethnicity' has never been used in Germany as a reference for national self-description, and still is not; rather, the term 'ethnic' indicates the affiliation of individuals with a non-German culture. Hence, intercultural pedagogy paradoxically performs an ethnic boundary-making unintentionally taking place in classrooms (Radtke, 1991). Due to this understanding of intercultural pedagogy as part of an institutionalized discrimination of migrant pupils (Gomolla & Radtke, 2002), a rejection of the established concept can be observed in the scholarly discussion of the last decade. Thus, the term 'diversity' offers a new semantical option for describing social differences while avoiding the racializing connotations of the older discourse (Hormel & Scherr, 2004).

Diversity-concepts usually provide lists of group-categories (race, class, gender, religion, nationality, language etc.) which can be ascribed to individuals in order to cons-

1

tract a social reality relevant for educators. As the differentiation of individuals for educational purposes is the practical target, a broad variety of social categories seems to support the corresponding pedagogical practices applied within the school system. Taking the institutionalized separation of regular and special-needs schools into account, diversity appears to be a concept primarily received with a focus on the regular classroom. From this point of view, inclusion appears as a generalized target group concept aimed at achieving general educational equity. But diversity-knowledge paradoxically supports the pedagogical classification of pupils and thus plausibilizes compensatory grouping practices. Hence, while the diversity concept semantically emphasizes participation and equity as basic principles, it ultimately serves the academic legitimization of educational differentiation (Emmerich & Hormel, 2013). Furthermore, a naturalistic notion of diversity dominates the scientific literature and policy programs in Germany. As a consequence, diversity concepts tend to reify the social categories that are educationally in use.

## 9 Diversity and students' differentiation strategies in teacher education

The concept of heterogeneity has become a common pivot point for diversity-oriented strategies in pre-service teacher education in the German states (KMK, 2015). The idea of a given diversity of individual learning dispositions, such as motivation, knowledge, interest, effort and ability, legitimizes the development as well as the application of *differentiating* ('adaptive') didactical concepts in particular. Moreover, common heterogeneity concepts (Bohl et al., 2017) also include social categorizations such as gender, migration background, and language skills. The idea of diversity seems to provide a conceptual blueprint for the integration of the aforementioned social categories and their use for purposes of student classroom differentiation. Diversity concepts designed for teacher education appear to focus mostly on the former field of 'intercultural education', which they re-actualize with new semantics of difference and normative educational purposes, such as the recognition of being divers. But only few academic publications deal with the question of how the cultural diversity perspective can be developed and implemented systematically (Barsch, Glutsch & Massumi, 2017). Hence, one obstacle generated in the field of educational research itself seems to be the categorical single-axis orientation of educational scientists who concentrate on one target group, e.g., pupils with a so-called 'migration background' (Allemann-Ghionda, 2017). As with all constructions of diversity, the tendency to essentialize and naturalize societally and institutionally generated 'differences' continually leads

to the reification of socially constructed categories and thus makes it difficult to develop a convincing diversity concept in education science. However, beyond the epistemic problems, single-category concepts of diversity seem to meet the target group logic of compensatory educational policies and measures such as early language support or SEN support.

### **10 Designing inclusion: educational concepts for a highly selective school system**

In 2009, Germany ratified the UN-CRPD (Convention on the Rights of Persons with Disabilities), thereby agreeing to “ensure an inclusive education system at all levels” (UN-CRPD, 2006, p. 16). As a result, a nationwide implementation process was initialized by the sixteen German states, aiming to install inclusive education structures, that is, to develop organizational and professional requirements for realizing the ‘inclusive classroom’.

A decade after the ratification of the UN-CRPD and the gradual inclusion-based school reforms, the conceptual and organizational realization of an inclusive education system in Germany is still highly controversial. This applies to debates within the scholarly discourse and in practice, as well as to debates on a policy level. Observing these academic debates and national as well as federal policies, it is possible to identify a diverse spectrum of pedagogical concepts and implementation strategies, which we will attempt to outline in this section. We will do so by tracing the evolution and recent developments of two educational approaches. These approaches shape the current discourse and can thus be seen as representatives for the discussion about inclusion and its implementation in Germany, namely inclusive pedagogy (Inklusionspädagogik) and special education (Sonderpädagogik).

Inclusive pedagogy as a discipline and as a professional practice in the German context emerged at the turn of the 20<sup>th</sup> century. It resulted from a critical evaluation and overcoming of integrative pedagogy with its “two-group-theory” (Hinz, 2012, p. 33), which is based on the conceptual separation of persons with disabilities from persons without disabilities. Furthermore, inclusive pedagogy criticizes a narrow understanding of inclusion, which targets individual pupils with special educational needs (SEN) and is oriented to supportive pedagogies (Emmerich & Hormel, 2013). Inclusive pedagogy thus pleads for a broad understanding of inclusion that embraces all categories of heterogeneity and diversity (Budde & Hummrich, 2015). Since diverse definitions of inclusion appear in this area of tension, and since there is no generally

accepted understanding of and strategy for the implementation of inclusion, scholars note a deficiency of definition (Hinz, 2013; Moser & Lütje-Klose, 2016). When attempting to define inclusion *ex negativo* as the “reduction of all barriers that hinder formal and factual participation in high-quality educational programs in the regular school system” (Emmerich & Moser, 2020, p. 14), the entanglements with Germany's stratified and highly differentiated educational system come to the fore. Embedded in a tradition of “institutionalization of self-referential systems of segregated special schooling” (Pfahl & Powell, 2014, para. 19) the German educational system is still mainly characterized by “interschool segregation” (Powell, 2016, p. 219). Although the federally organized German school system has gradually been getting into motion since the ratification of the UN-CRPD, measures to implement inclusion are still crucially shaped by the professional logic of special education (Biermann, Pfahl & Powell, 2020). For instance, special education pedagogies that focus on individual support are also maintained in the context of existing mutual schooling, as the practice of ‘team teaching’ shows (Böhm, Felbermayr & Biewer, 2018). Furthermore, as Powell (2010) indicates, the institutionalization of special education classification systems induced a growing number of children to be diagnosed as ‘disabled’.

## 11 Inclusion and the paradox of professionalization

After implementing the UN-CRPD, several German states aimed to abolish separated SEN-schools, while other states perpetuated the segregated SEN-school structure but added new organizational elements, such as ‘external’ SEN-classes that temporarily took place in regular schools, as is the case in Baden-Württemberg. Nevertheless, the implementation of inclusive structures raises questions regarding the adequacy of professionalization strategies. These can be discussed from three perspectives.

Firstly, since special education as a profession that focuses on children with special educational needs is already established in Germany, some scholars and policymakers advocate for its maintenance (Ahrbeck, 2014). This applies to the special education schools as well as to the professionalization of special education teachers, which takes place separately from general teacher training. The contents of the special education teacher training are above all supportive pedagogies (Förderpädagogiken) (Heimlich & Kiel, 2020).

Secondly, with the rise of Disability Studies (DS) in Germany, the conceptualization of SEN and the SEN-profession is increasingly challenged by DS scholars who aim at “eliminating the divide between special and general education” and emphasize “inclu-



sive education for all.” (Pfahl & Powell, 2014, para. 9). DS bases its understanding of inclusion on a social, human rights-oriented and cultural model of disability that demands structural change to allow the full participation of persons with disabilities (Brehme, Fuchs, Köbsell & Wesselmann, 2020). Thus, DS supports implementing a broad understanding of inclusion in general teacher training, which puts the predominance of the special education profession at risk.

Within inclusive pedagogy, there is widespread agreement that the initiated restructuring of the school system has made it necessary to incorporate inclusive teaching curricula into general teacher training as well. Nonetheless, questions arise when defining to what extent this should take place. This is also indicated by educational scientists, as the development of concrete didactics that embrace a broad inclusive understanding is not yet complete (Pech, Schomaker & Simon, 2017). Thirdly, from the perspective of DS and inclusive pedagogy, inclusion raises questions regarding the reorganization of regular teacher training, as well as regarding concrete competencies that have yet to be conceptualized and implemented in teacher training programs (Emmerich & Moser, 2020).

## **1.2 Diversity and inclusion in Germany: a social question**

The historical view of the German school system raises the following question: will recent policies aimed at implementing inclusive education programs change the structure of the system or will the established “grammar of school education” (Tyak & Tobin, 1993) ultimately change the concept and goals of inclusive education? What we can empirically observe is a convergence of both, the concept and the structures, leading to a reform that changes the idea rather than the system.

A retrospective view on Germany's inclusion policies in the last decade sheds light on a process characterized by heterogeneous policy strategies, diverging organizational forms, and ambiguous results regarding educational inequality and social participation opportunities (Klemm, 2018). SEN schools were and continue to be schools for ‘poor people’, a statistical overrepresentation of disadvantaged social classes being well-documented. Boys with a so-called ‘migration background’, for instance, are currently the most overrepresented group (Powell & Wagner, 2014). Inclusion in Germany is therefore a social question, but this question results from the school system's internal structures and practices. Paradoxically, inclusive schooling strategies are mostly designed to be compensatory programs guided by the implicit logic of social prevention

### 13 Conclusion: what to learn from a South Africa—Germany comparison?

What ‘inclusion’ means, what it can do, and what it is good for depends on the established ‘grammar of schooling’ that characterizes each national education system. Interpretations of the idea of educational inclusion seem to vary with organizational school structures, institutionalized educational cultures, and the power of educational professions (Tomlinson, 2017). Since the concepts of educational inclusion, seen as solutions, differ from one country to another, a corresponding variety of specific problems can be expected for each country.

What applies to inclusion also seems to apply to the construction of diversity: adopted by scholars and policymakers, educational concepts of diversity implicitly describe the relationship between the education system and society. However, they do so from the system's perspective, guided by the system's purposes and by the contradictions and paradoxes produced by the systems. They make sense of the concept by matching the idea of diversity to the system's structures and routinized practices. Thus, the way diversity is pedagogically constructed says more about the constructor than about the constructed.

What both studies show is how ideas of diversity, the concept of inclusive education, and its legacies of attainment and traction are socially constructed by complex local conditions. On the one hand, the South African situation articulates complex interdependencies between education policies and the political project of building a post-Apartheid welfare state that not only provides equal access to education for all societal groups, but also empowers these groups to broadly participate in the national education system. On the other hand, the German situation is contoured by a strategy which matches the ideas of diversity and inclusion to the established national ‘grammar of schooling’, maintaining the existing organizational structures and professional practices for differentiating students. While ‘inclusion’ policies may have the potential to change South African schooling, the German system seems to change the conception of inclusion.

Besides the apparent differences, we can also see common problems guiding the implementation of diversity and inclusion programs: in both cases, first and foremost, inclusion is an answer given to persistent social questions, be it the literacy of a population, political and economic participation, the integration of refugees, or the abolishment of an ‘irregular’ SEN-school system separating students from regular school.

Secondly, to successfully implement inclusive structures, both national education systems need to reform the internal structures that produce inequality through schooling. Thirdly, the crucial task and challenge of educational studies is to critically reflect and systematically support this transformation process by developing advanced concepts of diversity and inclusion. These are to enable policy makers, school administrators, school leaders and teachers to avoid expected dead-end strategies, such as compensatory measures and target group education.

What both studies highlight is how discussions on the complex cultural, social, political and historical forces that are present in individual countries and contexts are critical in understanding how the ideas of inclusive education and diversity are expressed and acted upon in various different countries. They show that inclusive education is a constantly evolving process inextricably tied to individual countries and their unique contexts, and in direct relation to their evolving needs. Comparative studies like these have the advantage of providing us with a valuable opportunity to learn from each other's lived realities.

### Literature

- Abdulrahman, H. K., Adebisi, F., Nwako, Z., & Walton, E. (2021). Revisiting (inclusive) education in the postcolony. *Journal of the British Academy*, 9(1), 47–75.
- Ahrbeck, B. (2014). Schulische Inklusion—Möglichkeiten, Dilemmata und Widersprüche [School inclusion: Possibilities, dilemmas and contradictions]. *Soziale Passagen*, 6(1), 5–19.
- Allemann-Ghionda, C. (2017). Zur diversitätsgerechten Professionalisierung angehender Lehrpersonen [On the diversity-oriented professionalization of prospective teachers]. *Beiträge zur Lehrerinnen- und Lehrerbildung*, 35(1), 139–151.
- Anderson, B. (1983). *Imagined communities: Reflections on the origin and spread of nationalism*. Verso.
- Andrews, D., Walton, E. & Osman, R. (2019). Constraints to the implementation of inclusive teaching: A cultural historical activity theory approach. *International Journal of Inclusive Education*. <https://doi.org/10.1080/13603116.2019.1620880>
- Autorengruppe Bildungsberichterstattung (2018). *Bildung in Deutschland 2018. Ein indikatorengestützter Bericht mit einer Analyse zu Wirkungen und Erträgen von Bildung* [Education in Germany 2018. An indicator-based report with an analysis on the effects and returns of education]. <https://www.bildungsbericht.de/de/bildungsberichte-seit-2006/bildungsbericht-2018/pdf-bildungsbericht-2018/bildungsbericht-2018.pdf> [06.14.2021].
- Barsch, S., Glutsch, N., & Massumi, M. (Eds.) (2017). *Diversity in der LehrerInnenbildung. Internationale Dimensionen der Vielfalt in Forschung und Praxis* [Diversity in teacher education. International dimensions of diversity in research and practice]. Waxmann.
- Biermann, J., Pfahl, L., & Powell, J. W. (2020). Mehrebenenanalyse schulischer Inklusion: Zwischen globaler Diffusion der Inklusionsrhetorik, behinderten Bildungskarrieren und institutionellen Pfadabhängigkeiten in Deutschland [Multilevel analysis of school inclusion: Between global diffusion of the inclusion rhetoric, disabled educational careers and institutional path dependencies in Germany]. In T. Dietze, D. Gloystein, V. Moser, A. Piezunka, L. Röbenack, L. Schäfer, G. Wachtel & M. Walm (Eds.), *Inklusion—Partizipation—Menschenrechte. Transformationen in die Teilhabegesellschaft?* (pp. 195–201). Klinkhardt.
- Bohl, T., Budde, J., & Rieger-Ladich, M. (Eds.) (2017). *Umgang mit Heterogenität in Schule und Unterricht. Grundlagen-theoretische Beiträge, empirische Befunde und didaktische Reflexionen* [Dealing with heterogeneity in schools and classes. Basic theoretical contributions, empirical findings and didactic reflections]. Klinkhardt.

- Böhm, E. T., Felbermayr, K., & Biewer, G. (2018). Zentrale Forschungsbefunde zur Inklusion in der Schule [Central research findings on inclusion in schools]. In T. Sturm & M. Wagner-Willi (Eds.), *Handbuch schulische Inklusion* (pp. 143–157). Barbara Budrich.
- Brehme, D., Fuchs, P., Köbsell, S., & Wesselmann, C. (Eds.) (2020). Einleitung: Zwischen Emanzipation und Vereinnahmung [Introduction: Between emancipation and appropriation]. In D. Brehme, P. Fuchs, Köbsell S. & C. Wesselmann (Eds.), *Disability Studies im deutschsprachigen Raum: Zwischen Emanzipation und Vereinnahmung* (pp. 9–21). Beltz Juventa.
- Budde, J., & Hummrich, M. (2015). Inklusion aus erziehungswissenschaftlicher Perspektive [Inclusion from an educational science perspective]. *Erziehungswissenschaft*, 26(51), 33–41.
- Carrim, N. (2003). Race and inclusion in South African education. *IDS Bulletin*, 34(1), 20–28.
- Carrim, N. (2018). Difference in current post-apartheid education. In E. Walton & R. Osman (Eds.), *Teacher Education for Diversity* (pp. 153–167). Routledge.
- Chisholm, L. (2012). Apartheid education legacies and new directions in post apartheid South Africa. *Storia delle donne*, 8(1), 81–103.
- Christie, P. (2006). Changing regimes: Governmentality and education policy in post-apartheid South Africa. *International Journal of Educational Development*, 26(4), 373–381.
- Connor, D., Gabel, Gallagher, & Morton, M. (2008). Disability studies and inclusive education—implications for theory, research, and practice. *International Journal of Inclusive Education*, 12(5–6), 441–457.
- de Lange, J. (1981). Provision of education in the Republic of South Africa. Human Sciences Research Council.
- Department of Education (DoE). (2001). *Education white paper 6: Special needs education. building an inclusive education and training system*. Pretoria: Department of Education.
- Donohue, D., & Bornman, J. (2014). The challenges of realising inclusive education in South Africa. *South African Journal of Education*, 34(2), 1–14.
- Donohue, D.K., & Bornman, J. (2015). South African teachers' attitudes toward the inclusion of learners with different abilities in mainstream classrooms. *International Journal of Disability, Development and Education*, 62(1), 42–59.
- Emmerich, M., & Hormel, U. (2013). *Heterogenität—Diversity—Intersektionalität. Zur Logik sozialer Unterscheidungen in pädagogischen Semantiken der Differenz* [Heterogeneity—Diversity—Intersectionality. On the logic of social distinctions in pedagogical semantics of difference]. Springer VS.
- Emmerich, M., & Moser, V. (2020). Inklusion, Diversität und Heterogenität in der Lehrerinnen- und Lehrerbildung [Inclusion, diversity and heterogeneity in teacher education]. In C. Cramer, M. Drahmman, J. König, M. Rothland & S. Blömeke (Eds.), *Handbuch Lehrerbildung* (pp. 12–20). Utb.
- Engelbrecht, P. (2006). The implementation of inclusive education in South Africa after ten years of democracy. *European Journal of Psychology of Education*, 21(3), 253–264.
- Engelbrecht, P., Nel, M., Nel, N., & Tlale, D. (2015). Enacting understanding of inclusion in complex contexts: Classroom practices of South African teachers. *South African Journal of Education*, 35(3), 1–10.
- Enslin, P. (2003). Citizenship education in post-apartheid South Africa. *Cambridge Journal of Education*, 33(1), 73–83.
- Fiske, E. B., & Ladd, H. F. (2004). *Elusive equity: Education reform in post-apartheid South Africa*. Brookings Institution Press.
- Gomolla, M., & Radtke, F. O. (2002). *Institutionelle Diskriminierung. Die Herstellung ethnischer Differenz in der Schule* [Institutional discrimination. The production of ethnic difference in school]. Leske + Budrich.
- Graham, L., Medhurst, M., Malaquias, C., Tancredi, H., de Bruin, C., Gillett-Swan, J., Poed, S., Spandagou, I., Carrington, S., & Cologon, K. (2020). Beyond Salamanca: A citation analysis of the CRPD/GC4 relative to the Salamanca statement in inclusive and special education research. *International Journal of Inclusive Education*. <https://www.tandfonline.com/doi/full/10.1080/13603116.2020.1831627> [17.09.2021].







## Chapter 6

### Teacher Education in Germany— Mentoring in School Internships

Felician-Michael Führer and Tamara Falcone

*This chapter provides an overview of the current state of research on mentoring in practical teacher training, focussing on the quality of supervision and the relationships between mentor and mentee in practical phases at school. Using the example of the Lehr:werkstatt at Tübingen University's School of Education, it is shown how mentor-mentee interactions can be designed and what ideally distinguishes quality mentoring.*

*First, the general characteristics and peculiarities of teacher education in Germany are described, with a special focus on the relationship between theoretical studies and practical relevance, and the much-discussed role of school-based practical phases that are integrated into university studies. Subsequently, central research results on the status and effectiveness of such school internships are presented, and the concepts and forms of school-based mentoring are clarified. Particular attention is given to the quality of supervision and relationships in mentoring constellations.*

*In a research overview, current and central findings from review studies and empirical investigations are linked with each other. This part is concluded with a practical example: the Tübingen Lehr:werkstatt. This is a long-term internship integrated into the bachelor's program in which mentoring interactions play an essential role in developing the student teachers' professional competencies. In the final conclusion, it is critically noted that many mentoring concepts focus exclusively on the prospective teachers' teaching actions, overlooking the fact that professionalization processes can be protracted, non-linear, and characterized by crises and breaks, such that the role of mentoring in improving the quality of teaching can only ever be indirect. It is therefore demanded that mentors in mentoring interactions make multiple references to studies in the subject sciences, subject didactics, and educational sciences. By acting in a way that is both supportive and challenging, they broaden the students' as well as their own perspectives.*

<http://dx.doi.org/10.15496/publikation-76381>





## 1 Introduction

Teacher education in Germany is characterized by the structural and organizational changes of the last 10–15 years, exemplified by the 2004 transition to the bachelor-master structure. On the other hand, the discussion about successful teacher education has always been defined by the question of how science and professional practice should be related. The students' desire for more practice and for the integration of learning opportunities related to the professional field during the course of their studies is reflected, among other things, in a strengthening of modules in educational science and subject didactics, and in the introduction of extended practical phases, e.g., the practical semester (van Buer & Petzold-Rudolph, 2015). Thus, the structural reforms (in overview: KMK, 2014) can be seen as reactions to the so-called “PISA shock” of 2000/2001, but can also be addressed as part of the traditional discussion about the so-called “theory-practice-problem”.

Therefore, this contribution will not so much present the curricular reforms and structural/organizational features of teacher education in Germany—especially as the framework requirements are, in their details, implemented differently by the individual federal states, owing to the basic federalist structure of the German education system—as discuss a teaching concept of academic teacher education and professional practice, using the example of mentoring in school-based practical phases. For an orienting overview, we will first address questions of teacher education in Germany that concern the relationship between theory and practice.

## 2 Features of teacher education in Germany

From the perspective of competency theory, the teaching profession is characterized by the networking of different theoretical-formal knowledge areas (e.g., content knowledge, pedagogical content knowledge, pedagogical/psychological knowledge), which are proceduralized by means of extensive practical experience (Voss et al., 2015). The corresponding learning opportunities, in which declarative knowledge (theory), but also practical knowledge and skills (procedural knowledge or performative knowledge) are acquired, are for the most part institutionally separated in German teacher education (Blömeke, 2009a). This separation of theory and practice is particularly visible in the two-phase training structure that prospective teachers go through: in a first phase (the teacher education program), universities are primarily responsible for imparting theoretical-conceptual knowledge, while in the second phase (the teacher

traineeship), the study seminars and training schools focus on the acquisition of professional action competences (Blömeke, 2009b).

The background of these learning opportunities, which are separated institutionally, structurally, organizationally, and in terms of content, curriculum and personnel, is the idea that theory and practice have different functions and can be categorically distinguished from one another (Dewe & Radtke, 1991; Stadelmann, 2006), and that high-quality teacher education can therefore only be provided by specialists qualified for it. At universities, this is done by the academic staff of various faculties; at the study seminars and training schools, by vocational field experts. However, the adoption of the two perspectives (theory—practice) by different institutions, as well as their temporal succession in the (initial) education and training process, consolidate a separation that makes it difficult to proceduralize or compile the different knowledge dimensions needed for a holistic education and training of professional competences (knowledge and skills), or even, in some cases, prevents it entirely (Blömeke, 2009b).

The changeover to the bachelor-master structure at universities, the modularization of subject didactics and educational science content, and the integration of longer practical phases into university studies are now exemplary of a process that, since 2004, has been attempting to dovetail practice-related training more closely with sound academic training (Rothland, 2020).

The basic aim of the bachelor's-master's system is the cumulative development of professional skills. While the bachelor's program generally lasts six semesters and is designed as a basic study program in which the central theories, research methods and results of the respective discipline are addressed, the somewhat shorter master's program, which usually takes four semesters to complete, can be regarded as a continuation or in-depth study program in which specific subject-related didactic and pedagogical-psychological issues are negotiated.

However, while the bachelor's degree in teaching is a general professional qualification, only the subsequent master's degree entitles the holder to take up the preparatory service (Referendariat), which is a prerequisite for entering the teaching profession (van Buer & Petzold-Rudolph, 2015). This more competence- and expert-oriented structure, which emphasizes a sound theoretical and practice-oriented training in the respective subject, but also in cross-curricular areas, is also supplemented by the integration of longer periods of practice in this first phase of teacher education. Exemplary for this is the introduction of long-term internships in all federal states, e.g., the practical semester in Baden-Württemberg or the two-semester “Kernpraktikum” (“core internship”) in Hamburg (Weyland, 2014). In addition, there are other types

of internships, some of which are already completed by student teachers in the bachelor's program, e.g., the orientation internship at the beginning of their studies or the *Lehrwerkstatt* (Teaching:workshop) at the Tübingen School of Education (see 4). Common to all these practical phases is their ability to fulfil the desire of many student teachers for more practical relevance in the first phase of teacher education. However, empirical findings show that introducing more and longer practical experience does not automatically lead to the development of professional competences, and that it can even have a deprofessionalizing effect (Bonnet & Hericks, 2014). For this reason, the quality, concrete design and support of practical schooling phases have increasingly come into focus (Führer & Cramer, 2020b). For this reason, practical phases in teacher education will be examined below with regard to their benefit for the relationship between theory and practice.

### 3 Practical school phases in teacher education

School internships that are integrated into the teacher education program of the university have high value, especially among students, but also among practical support staff. They are positively assessed in terms of their usefulness and importance, and are regarded as an important component in the training of professional competences (Gröschner & Häusler, 2014), since teacher education in Germany also includes a practical school component in addition to subject-specific, subject-didactic, and educational science training (Blömeke, 2009a). Particularly for learning and development processes at the interface between university studies (theory teaching) and occupation-related activity (practical experience), school and teaching internships are assigned a central function from a learning theory perspective (Staub, Waldis, Futter & Schatzmann, 2014). This is usually justified by the assumption that school internships can link the theoretical and declarative knowledge acquired at university with concrete practical experience, and to transfer it via the mode of reflection into procedural, action-guiding knowledge and skills (Neuweg, 2011; Kreis, 2012). Empirically speaking, findings on the effectiveness of school internships and the development of professional competences vary (Hascher, 2012). This is especially because, from the perspective of research methodology, it is a multicomplex project to record all possible factors influencing (un)desired learning processes in teaching internships (Kreis & Staub, 2012). There is, however, a fundamental consensus that a purely quantitative increase in school-work placements (in terms of their respective duration or number in the study program) does not automatically lead to an increase

in the professional competences of future teachers (Hascher & de Zordo, 2015), and that problematic or deprofessionalizing effects can also be observed (Bach, 2013). Therefore, through the introduction of long-term internships such as the practical semester, the quality of the respective practical phases is moving into the focus of the studies, especially that of university or school support and supervision (Strong & Baron, 2004; Schubarth et al., 2009; Hascher, 2014; Futter, 2017). Of particular interest is the design and quality of the support (mentoring) given to the students by experienced or specially trained teachers (practical support staff and mentors) at the internship schools. For this reason, a rough overview of mentoring in school-based practical phases will be given below.

### 3.1 Mentoring in practical school phases

Mentoring is an internationally established practice as an accompaniment and support format in school practice phases. It contributes to the professionalization of future teachers in the professional field with the help of experienced practitioners (Clarke, Triggs & Nielsen, 2014). Mentoring can be seen as an instrument with which both practical-pedagogical action and scientific-reflexive thinking can be supported and stimulated, in the sense of a guided and accompanied professionalization process (Reintjes et al., 2018), which goes beyond a simple transfer of (experiential) knowledge. A review of the research literature shows, however, that in addition to different conceptual and terminological ideas, many different realization practices can be identified in mentoring (in overview: Führer & Cramer, 2020a).

Empirical studies on this (e.g., Evertson & Smithey, 2000) show that students who are accompanied by trained mentors exhibit more effective classroom management. Furthermore, they participate in lessons with greater commitment and discipline than students who are not supervised or who are accompanied by mentors not specifically trained (cf. Kreis & Staub, 2012). However, mentoring can also have unfavorable effects, e.g., if the routines of the mentors are taken over by the students without reflection (Hascher, 2012; Wenz & Cramer, 2019), or if traditional practices, e.g., in classroom meetings, lead to no theory-based reflection on teaching phenomena (Führer, 2020).

A high-quality relationship between the student and the mentor is regarded as an essential condition for supervised and accompanied work placements to have professionalizing effects and to promote sustainable learning by the prospective teachers (Besa & Büdcher, 2014; Wenz & Cramer, 2019). However, few studies model the construct relationship theoretically or examine which indicators can be used to describe the quality of the relationship that is considered significant (Wenz & Cramer, 2019; Führer & Cramer, 2020b).

### 3.2 Guidance quality and relationship quality in mentoring

Clarke, Triggs and Nielsen (2014) deduce from their research overview that, from the students' perspective, mentors make one of the most important contributions to their professional development in the school internship, and that a high-quality relationship is an essential condition for successful learning processes, even if the concrete forms of interaction are different (mentors as feedback providers, role models, reflection triggers, etc.).

Important indicators of high-quality relationship design are trust, appreciation, and emotional and psychological support (Hobson et al., 2009; Orland-Barak, 2016; Wenz & Cramer, 2019). Furthermore, the way in which the mentors perform their tasks in such a setting and the interactive roles they fulfil are central issues: the supervision proves most effective if the practical mentors voluntarily take over the supervision of the students (Hobson et al., 2009) and are interested in their mentees' learning process (Gröschner & Häusler, 2014). This can be a prerequisite for critical feedback to be accepted (Niggli, Gerteis & Gut, 2008) and for the behavior of the mentors to be seen as helpful.

In addition to the supportive behavior of the mentors, the time factor is also of major importance for the perceived quality of care (Borko & Mayfield, 1995), e.g., with regard to the resources spent on preliminary and follow-up meetings (Strong & Baron, 2004; Gröschner & Seidel, 2012; Futter, 2017). However, the mentors' supportive behavior alone does not automatically have professionalizing effects. Rather, challenging learning opportunities must also be initiated and used by students, which can be designed, for example, in classroom pre- and debriefings or in case work (Hobson et al., 2009; Staub & Kreis, 2013). The research available to date suggests that a good balance between support and challenge is particularly conducive to the development of professional skills (e.g., Orland-Barak, 2016; Wenz & Cramer, 2019; Führer & Cramer, 2020b).

In summary, the current research (in overview: Führer & Cramer, 2020a) points to diverse conditions for successful practical support and supervision. Although the literature focuses on specific aspects, there is no overarching theory or framework model for classifying the conceptual and empirical work as a whole.

## 4 Practical example: the Tübingen Lehr:werkstatt

Within the framework of the *Lehr:werkstatt* at the Tübingen School of Education, a student teacher (*Lehr:werker*) regularly accompanies a teaching mentor (*Lehr:men-*

tor) in their daily school and teaching routine for an entire school year. During the semester's lecture period, students spend one day a week at their internship school. During the lecture-free period, there are two block phases of two and three weeks' duration, in which students are present at the schools on a daily basis. In an accompanying seminar, for which the university is responsible, students reflect on their practical school experience under guidance and deepen it against the background of educational science and general educational theories and models. In addition, university-organized competence workshops, which are usually realized by subject specialists from science and school practice, offer the mentees and teaching mentors the opportunity to cooperate further as a tandem, and to develop and build on their respective professional competences.

To create favorable framework conditions for successful mentoring that promotes learning from the outset, an online matching tool was developed especially for the *Lehr:werkstatt*, which takes into account not only the subject combination and location wishes, but also the preferences, interests, personality traits and expectations of the students and the teaching staff when putting them together (cf. Benz, 2017).

The realistic insight students gain into the teaching profession and everyday school life during the *Lehr:werkstatt* placement can be used, on the one hand, for an individual review of the study and career choice, but can also, on the other hand, lead to a changed view of the teacher education program's contents and objectives. While a large number of teaching students still complain about their studies' lack of practical relevance to the professional field (already in Plöger & Anhalt, 1999), a long-term internship such as the *Lehr:werkstatt* offers the opportunity to apply in class the theoretical knowledge acquired in seminars (e.g., teaching forms and methods) and also to reflect on the practical experience gained at school in the supplementary *Lehr:werkstatt* seminars and workshops. The teaching experience, the exchange with the mentor and other mentees, as well as the impulses from the university events, can lead to the development of professional competences during the *Lehr:werkstatt* internship, from which the students can benefit both in the further course of their studies and with regard to future practical phases (e.g., the practical semester).

The ability to reflect is of crucial importance for the development and further development, but also the maintenance of professional competences (Combe & Kolbe, 2008; Häcker, 2017). In the context of teacher education, reflexivity is even seen as a “condition for the emergence of pedagogical expertise” (Neuweg, 2011). Thus, reflecting on and talking about one's own and observed teaching activities not only plays a central role in the professionalization of future teachers, but can also support experienced teachers in reviewing their own convictions and routines.

## 5 Conclusion

Concepts that orient mentoring towards the concrete guidance of the mentors' action patterns, as well as their adoption by the mentees, should always be subjected to critical examination. The development of teaching staff from novice to expert, described in an ideal-typical way by expertise research, must not conceal that professionalization processes, as they can be stimulated in practical phases, are often lengthy, non-linear, and characterized by crises and breaks, leading to a professional biographical process lasting several years. However, the strong focus of many mentoring concepts on the teaching process could distract from the fact that attitudes and beliefs, self-regulatory skills, motivational orientations and domain-specific knowledge are also characteristics of professional (action) competences (Baumert & Kunter, 2006; König, 2018). The role of mentoring in improving the quality of schools and teaching should thus always be indirect, in the sense that it results in (changed) actions by prospective teachers, which in turn has a positive effect on the students' learning (Cramer & Rothland, 2020).

If concepts of mentoring are based on a technological understanding or assume an ideal-typical logic of development from novice to expert, they contradict more complex ideas about the development of professionalism, which are oriented towards the uncertainty in the pedagogical field of action and understand teacher education as a complex, multi-perspective and multi-paradigmatic issue (Heinrich et al., 2019). If mentoring aims to prepare teachers for their complex tasks, it cannot close its eyes to the uncertainty of the teaching reality. This would be ignored if simple answers to complex questions were given and receptive unambiguities were the subject of mentoring. Mentors should therefore be required to establish a variety of references to studies in the subject sciences, subject didactics, and educational sciences. A high-quality relationship design can be conducive to the professionalization of mentees, especially if mentoring can broaden perspectives through support and challenge (Führer & Cramer, 2020a).

### Literature

- Bach, A. (2013). *Kompetenzentwicklung im Schulpraktikum. Ausmaß und Stabilität von Lerneffekten hochschulischer Praxisphasen* [Competence development in the school internship. Extent and stability of university internship phases' learning effects]. Waxmann.
- Baumert, J., & Kunter, M. (2006). Stichwort: Professionelle Kompetenz von Lehrkräften [Professional competence of teachers]. *Zeitschrift für Erziehungswissenschaft*, 9(4), 469–520.
- Besa, K. S., & Büdcher, M. (2014). Empirical evidence on field experiences in teacher education: A review of the research base. In K. H. Arnold, A. Gröschner & T. Hascher (Eds.), *Schulpraktika in der Lehrerbildung. Theoretische Grundlagen, Konzeptionen, Prozesse und Effekte* (pp. 129–145). Waxmann.

- Benz, E. (2017). Lehr:werkstatt—Ein Impuls für neue Wege in der Lehrerbildung [Lehr:werkstatt—An impulse for new ways in teacher education]. *Schulverwaltung spezial*, 19, 209–211.
- Blömeke, S. (2009). Lehrerausbildung in Deutschland [Teacher education in Germany]. *PÄD-Forum*, 1, 5–8.
- Blömeke, S. (2009). Lehrerausbildung [Teacher training]. In S. Blömeke, Th. Bohl, L. Haag, G. Lang-Wojtasik & W. Sacher (Eds.), *Handbuch Schule. Theorie—Organisation—Entwicklung* (pp. 483–490). Klinkhardt/UTB.
- Bonnet, A., & Hericks, U. (2014). Professionalisierung und Deprofessionalisierung im Lehrer/innenberuf: Ansätze und Befunde aktueller empirischer Forschung [Professionalization and deprofessionalization in the teaching profession: Approaches and findings of current empirical research]. *Zeitschrift für interpretative Schul- und Unterrichtsforschung*, 3, 3–13.
- Borko, H., & Mayfield, V. (1995). The roles of the cooperating teacher and university supervisor in learning to teach. *Teaching and Teacher Education*, 11(5), 501–518.
- van Buer, J., & Petzold-Rudolph, K. (2015). Die ‚neue‘ Lehrerbildung in Deutschland. Vom Praxisschock zur aufgeklärten Aneignung professionellen Handelns?—Lehrerbildung als systematischer Teil der Bildungsreform [The ‘new’ teacher education in Germany. From practical shock to enlightened appropriation of professional action?—Teacher education as a systematic part of educational reform]. *International Journal for 21<sup>st</sup> Century Education*, 2, 938.
- Clarke, A., Triggs, V., & Nielsen, W. (2014). Cooperating teacher participation in teacher education. *Review of Educational Research*, 84(2), 163–202.
- Combe, A., & Kolbe, F. U. (2008). Lehrerprofessionalität. Wissen, Können, Handeln [Teacher professionalism. Knowledge, ability, action]. In W. Helsper & J. Böhme (Eds.), *Handbuch der Schulforschung* (pp. 857–877). VS Verlag für Sozialwissenschaften.
- Cramer, C., & Rothland, M. (2020). Pädagogische Professionelle in der Schule [Educational professionals in school]. In T. Hascher, W. Helsper & T. S. Idel (Eds.), *Handbuch der Schulforschung* (3<sup>rd</sup> ed.). Springer.
- Dewe, B., & Radtke, F. O. (1991). Was wissen Pädagogen über ihr Können? Professionstheoretische Überlegungen zum Theorie-Praxis-Problem in der Pädagogik [What do educators know about their know-how? Professional-theoretical reflections on the theory-practice problem in pedagogy]. *Zeitschrift für Pädagogik*. 27. Beiheft: *Pädagogisches Wissen*, 143–162. Beltz.
- Evertson, C. M., & Smithey, M. W. (2000). Mentoring effects on protégés’ classroom practice: An experimental field study. *The Journal of Educational Research*, 93(5), 294–304.
- Futter, K. (2017). *Lernwirksame Unterrichtsbesprechungen im Praktikum. Nutzung von Lerngelegenheiten durch Lehramtsstudierende und Unterstützungsverhalten der Praxislehrpersonen* [Learning-effective classroom discussions in the internship. Use of learning opportunities by teaching students and supportive behavior of practical teachers]. Klinkhardt.
- Führer, F. M., & Wenz, K. (2019). Das Projekt Lehr:werkstatt der Tübingen School of Education—eine alternative Praktikumsform im Lehramtsstudium [The Lehr:werkstatt project of the Tübingen School of Education—an alternative form of internship in the teacher education program]. *Lehren & Lernen*, 8/9, 22–26.
- Führer, F. M. (2020). *Unterrichtsnachbesprechungen in schulischen Praxisphasen. Eine empirische Untersuchung aus inhalts- und gesprächsanalytischer Perspektive* [Lesson debriefings in school practice phases. An empirical study from the perspective of content and conversation analysis]. Springer.
- Führer, F. M., & Cramer, C. (2020a). Mentoring und Mentorierenden-Mentee-Beziehung in schulpraktischen Phasen der Lehrerinnen- und Lehrerbildung [Mentoring and the mentor-mentee relationship in practical school phases of teacher education]. Ein Überblick zu Definitionen, Konzeptionen und Forschungsbefunden. In G. Hagenauer & D. Raufelder (Eds.), *Soziale Eingebundenheit—Sozialbeziehungen im Fokus von Schule und Lehrer\*innenbildung*. Waxmann.
- Führer, F. M., & Cramer, C. (2020b). Qualität der Mentorierenden-Mentee-Beziehung in der schulpraktischen Lehrerinnen- und Lehrerbildung. Empirische Validierung und Ausdifferenzierung [Quality of the mentor-mentee relationship in school-based teacher education. Empirical validation and differentiation]. In K. Rheinländer & D. Scholl (Eds.), *Verlängerte Praxisphasen in der Lehrer\*innenbildung: Spannungsfelder zwischen Theorie, Praxis und der Bestimmung von Professionalisierung* (pp. 331–350). Springer.
- Gröschner, A., & Seidel, T. (2012). Lernbegleitung im Praktikum—Befunde und Innovationen im Kontext der Reform der Lehrerbildung [Learning support in the internship—findings and innovations in the context of teacher education reform]. In W. Schubarth, K. Speck, A. Seidel, C. Gottmann, C. Kamm & M. Krohn (Eds.), *Studium nach Bologna* (pp. 171–183). Springer.
- Gröschner, A., & Häusler, T. (2014). Inwiefern sagen berufsbezogene Erfahrungen und individuelle Einstellungen von Mentor\*innen die Lernbegleitung von Lehramtsstudierenden im Praktikum voraus? [To what extent do professional expe-



- riences and individual attitudes of mentors predict the learning support of teaching students in the internship? In K. H. Arnold, A. Gröschner & T. Hascher (Eds.), *Schulpraktika in der Lehrerbildung: Theoretische Grundlagen, Konzeptionen, Prozesse und Effekte* (pp. 315–333). Waxmann.
- Hascher, T. (2012). Forschung zur Bedeutung von Schul- und Unterrichtspraktika in der Lehrerinnen- und Lehrerbildung [Research on the importance of school and teaching internships in teacher education]. *Beiträge zur Lehrerinnen- und Lehrerbildung*, 30(1), 87–98.
- Hascher, T., & der Zordo, L. (2015). Langformen von Praktika. Ein Blick auf Österreich und die Schweiz [Long forms of internships. A look at Austria and Switzerland]. *Journal für Lehrerinnen- und Lehrerbildung*, 15(1), 22–32.
- Häcker, Th. (2017). Grundlagen und Implikationen der Forderung nach Förderung von Reflexivität in der Lehrerinnen- und Lehrerbildung [Foundations and implications of the demand for promoting reflexivity in teacher education]. In C. Berndt, Th. Häcker & T. Leonhard (Eds.), *Reflexive Lehrerbildung revisited* (pp. 21–45). Klinkhardt.
- Heinrich, M., Wolfswinkler, G., van Ackeren, I., Bremm, N., & Streblov, L. (2019). Multiparadigmatische Lehrerbildung. Produktive Auswege aus dem Paradigmenstreit? [Multi-paradigmatic teacher education. Productive ways out of the paradigm conflict?] *Die Deutsche Schule*, 111(2), 244–259.
- Hobson, A. J., Ashby, P., Malderez, A., & Tomlinson, P. D. (2009). Mentoring beginning teachers: What we know and what we don't. *Teaching and Teacher Education*, 25(1), 207–216.
- König, J. (2018). Erziehungswissenschaft und der Erwerb professioneller Kompetenz angehender Lehrkräfte [Educational science and the acquisition of prospective teachers' professional competence]. In J. Böhme, C. Cramer & C. Bressler (Eds.), *Erziehungswissenschaft und Lehrerbildung im Widerstreit!?* (pp. 62–81). Klinkhardt.
- Kreis, A. (2012). *Produktive Unterrichtsbesprechungen. Lernen im Dialog zwischen Mentoren und angehenden Lehrpersonen* [Productive classroom discussions. Learning in the dialog between mentors and prospective teachers]. Haupt.
- Kreis, A., & Staub, F. (2012). Lernen zukünftiger Lehrpersonen im Kontext von Unterrichtsbesprechungen im Praktikum—multiple Indikatoren für ein schwer zu fassendes Phänomen [Future teachers' learning in the context of classroom discussions in the internship—multiple indicators for an elusive phenomenon]. In M. Gläser-Zikuda, T. Seidel, C. Rohlf, A. Gröschner & S. Ziegelbauer (Eds.), *Mixed Methods in der empirischen Bildungsforschung* (pp. 209–226). Waxmann.
- Kultusministerkonferenz (2014). *Sachstand in der Lehrerbildung* [State of affairs in teacher education]. KMK.
- Neuweg, G. H. (2011). Distanz und Einlassung. Skeptische Anmerkungen zum Ideal einer „Theorie-Praxis-Integration“ in der Lehrerbildung [Distance and admission. Sceptical remarks on the ideal of a “theory-practice integration” in teacher education]. *Erziehungswissenschaft*, 22(43), 33–45.
- Niggli, A., Gerteis, M., & Gut, R. (2008a). Wirken—erkennen—sich selbst sein: Validierung unterschiedlicher Interessen von Studierenden und Praxislehrpersonen in Unterrichtsbesprechungen [Working—recognizing—being oneself: Validating different interests of students and practice teachers in classroom discussions]. *Beiträge zur Lehrerbildung*, 26(2), 140–153.
- Orland-Barak, L. (2016). Mentoring. In J. Loughran & M. L. Hamilton (Eds.), *International Handbook of Teacher Education*, 2, 105–141. Springer.
- Plöger, W., & Anhalt, E. (1999). Was kann und soll Lehrerbildung leisten?: Anspruch und „Realität“ des erziehungswissenschaftlichen Studiums in der Lehrerbildung [What can and should teacher education achieve?: Claim and „reality“ of educational science studies in teacher education]. Deutscher Studienverlag.
- Reintjes, C., Bellenberg, G., & im Brahm, G. (Eds.) (2018). *Mentoring und Coaching als Beitrag zur Professionalisierung angehender Lehrpersonen* [Mentoring and coaching as a contribution to the professionalization of prospective teachers]. Waxmann.
- Rothland, M. (2020). Legenden der Lehrerbildung. Zur Diskussion einheitsstiftender Vermittlung von ‚Theorie‘ und ‚Praxis‘ im Studium [Legends of teacher education. On the discussion of the unifying mediation of ‘theory’ and ‘practice’ in studies]. *Zeitschrift für Pädagogik*, 66(2), 270–287.
- Schubarth, W., Speck, K., Seidel, A., Gottmann, C., Kamm, C., & Krohn, M. (2012). Das Praxissemester im Lehramt—ein Erfolgsmodell? Zur Wirksamkeit des Praxissemesters im Land Brandenburg [The practical semester in the teaching profession—a successful model? On the effectiveness of the practical semester in the state of Brandenburg]. In W. Schubarth, K. Speck, A. Seidel, C. Gottmann, C. Kamm & M. Krohn (Eds.), *Studium nach Bologna: Praxisbezüge stärken?! Praktika als Brücke zwischen Hochschule und Arbeitsmarkt* (pp. 137–170). Springer.
- Stadelmann, M. (2006). Differenz oder Vermittlung? Eine empirisch-qualitative Studie zum Verhältnis von Theorie und Praxis in der Ausbildung von Lehrkräften für die Primar- und Sekundarstufe [Difference or mediation? An empirical-qua-

litative study on the relationship between theory and practice in the training of primary and secondary school teachers]. Haupt.

Staub, F., Waldis, M., Futter, K., & Schatzmann, S. (2014). Unterrichtsbesprechungen als Lerngelegenheiten im Praktikum [Classroom discussions as learning opportunities in the internship]. In K. H. Arnold, A. Gröschner & T. Hascher (Eds.), *Schulpraktika in der Lehrerbildung: Theoretische Grundlagen, Konzeptionen, Prozesse und Effekte* (pp. 287–309). Waxmann.

Strong, M., & Baron, W. (2004). An analysis of mentoring conversations with beginning teachers: suggestions and responses. *Teaching and Teacher Education*, 20(1), 47–57.

Voss, T., Kunina-Habenicht, O., Hoehne, V., & Kunter, M. (2015). Stichwort Pädagogisches Wissen von Lehrkräften: Empirische Zugänge und Befunde [Keyword pedagogical knowledge of teachers: Empirical approaches and findings]. *Zeitschrift für Erziehungswissenschaft*, 18(2), 187–223.

Wenz, K., & Cramer, C. (2019). Die Mentor-Mentee-Beziehung in der schulpraktischen Lehrerbildung. Theoretische Modellierung und Operationalisierung [The mentor-mentee relationship in school-based teacher education. Theoretical modelling and operationalization]. *Zeitschrift für empirische Hochschulforschung*, 3(1), 28–43.

Weyland, U. (2014). Schulische Praxisphasen im Studium: Professionalisierende oder deprofessionalisierende Wirkung? [Practical phases at school during studies: Professionalizing or deprofessionalizing effect?] *bwp@ Berufs- und Wirtschaftspädagogik – online*, Profil 3, 1–24. [http://www.bwpat.de/profil3/weyland\\_profil3.pdf](http://www.bwpat.de/profil3/weyland_profil3.pdf) [29.06.2021].



## Chapter 7

### Pre-Service Teacher Professionalization: Becoming a Teacher in South Africa

Emmanuel Mushayikwa and Ngonidzashe Mushaikwa

*In this book chapter, the authors focus on pre-service teacher professionalization through the medium of teaching experience at a South African university. They first provide an overview of the policy guidelines and expectations of teacher professionalization in South Africa and proceed with one example of their implementation at Wits University. They then present a case study in which teacher professionalization was implemented through teaching practice supervision and mentoring for pre-service science teachers in both B.Ed. and PGCE programs. Using the comments of supervisors and mentor teachers, as well as the students' self-reflections, they will use Legitimation Code Theory (LCT) to provide insights into how students see themselves acquiring a professional identity. The findings suggest that, frequently, there were mismatches between university lecturers' and school mentors' expectations, resulting in the teaching students acquiring fragmented knowledge about what it means to become a teacher. Arriving at these conclusions about teaching student professionalization, we recommend a more integrated approach to teaching experience supervision between school and university, leading to a professionalization partnership.*

#### 1 Introduction

There is no doubt that teaching experience is fundamental to becoming a teacher. In South Africa and many other countries, the teaching internship is widely accepted as part of the professionalization of student teachers. Although there have been many

<http://dx.doi.org/10.15496/publikation-76380>



studies relating to professionalization through practical experience in other disciplines, such as nursing and medicine, fewer studies have focused on student teacher professionalization through teaching practice. In this chapter, the authors explore the role of student teacher supervision and mentorship in addressing the challenges of professionalization. They argue that school experience is essential to the professionalization of novice teachers. They further argue that the impression student teachers acquire during teaching experience are paramount in determining their attitudes towards the teaching profession when they graduate. It is therefore logical to assume that the quality of supervision and mentorship during teaching experience will influence how the pre-service teachers perceive the teaching profession.

This chapter seeks to understand how pre-service teacher supervision is practiced by university lecturers and school-based mentors at a South African university. The research applies the Legitimation Code Theory (LCT) to investigate how professional knowledge is accumulated through the teacher supervision and mentoring methods applied. The authors will apply the specialization concept from LCT to profile the mentor/mentee relationship with regards to professional and classroom efficacy. This will be illustrated through the document analysis of supervision templates used by teachers and university supervisors during school visits. Finally, the chapter will look at how well the supervision/mentorship process aligns with the two aspects of teacher efficacy mentioned above. The chapter then concludes with some recommendations aimed at improving the efficacy of the supervision process for both teachers and university supervisors.

The authors use the term “professionalization” to refer to the process by which student teachers are inducted into the practice of teaching. This process includes the development of the teachers' professional identity, as well as their expertise in classroom management and competence. Professionalization can thus be viewed as the process by which teachers acquire efficacy as professionals. Mushayikwa (2013) identifies teacher efficacy as comprising two interconnected efficacies: classroom efficacy and professional efficacy.

### 1.1 The South African education context

Prior to 1994, the South African education system was one of the most complex systems in the world. The apartheid system's legacy ensured the existence of nineteen Departments of Education (Gordon, 2009) to cater to the perceived interests of the various racial groups within the country. Each of these departments had its own standards for teaching and learning, and there was very little cohesion (Ogunniyi & Mus-

hayikwa, 2015). According to social critical theory (Leonard, 2004) this state of chaos was not accidental, but reflected the architecture of Apartheid, whose goal was to privilege certain races according to skin color. Bengu (1995) reports that at the onset of democracy, the Government of President Nelson Mandela, which advocated for equal rights and justice for all, was faced with the mammoth task of amalgamating these disparate departments into one unified and truly national system of education and training, providing quality education to meet the aspirations of the Rainbow Nation's youth. The task also involved attending to aspects of quality education for all, equity in the distribution of resources, and the development of a teaching force that understood and articulated the aspirations of the young democracy. According to Ogunniyi and Mushayikwa (2015), this was necessary to address the parochial, unjust and exclusivist nature of the apartheid education system.

The following strategies were used:

- A. The establishment of National Departments of Basic and Higher Education
- B. The merger of FET colleges and universities and in particular, the subsumption of Teachers' Colleges into universities
- C. The development of a single, unified National Qualifications Framework of Education providing a continuum of credits for achievement, from kindergarten to doctoral qualifications
- D. The development of an outcomes-based curriculum and
- E. The development of a single national framework for teacher education and development

After the demise of Apartheid in 1994, as one of the first actions carried out by the new dispensation, a single National Department of Basic Education was established by dissolving the multiple education boards and creating a single ministry. The aim of this, according to the ANC's policy paper on education (ANC, 1994), was to remove segregation in the education sector, to ensure unity of purpose in the education system, and also to increase access to higher quality education for learners from previously disadvantaged groups.

Prior to the onset of democracy in 1994, the higher education sector had a myriad of institutions for training teachers. Teacher training colleges, technikons and universities all vied for the right to train teachers. In the Homelands and Bantustans, college-trained teachers were released into schools. Some of these teachers did not have adequate subject matter content to teach effectively, whereas the universities mainly supplied teachers to private, privileged and former model C schools. This diversity in

teacher training strategies perpetuated inequalities in the matriculants' education and career prospects, and maintained the legacy of Apartheid. Inequalities in higher education opportunities served as bastions of the apartheid socio-economic fabric. To dismantle these divisive structures, it was therefore necessary to restructure the higher education sector as well. Higher education institutions were thus rationalized through mergers to ensure that their qualifications upheld comparable standards across the sector.

This restructuring culminated in a single unified national qualification framework system using credits. This system assigns credits for each level of educational development, from kindergarten to the PhD level. Using this system, it is possible to compare qualifications, both intra- and internationally.

Although these changes were far-reaching and fundamental in terms of the country's democratic aspirations, it was recognized even then that, if these ideals were to be met, there had to be changes in the national curriculum itself. This called for a completely different approach to education. The outcomes-based education curriculum was designed to mold a new South African, free from racial prejudice, progressive and able to fully participate in the country's economy.

### 1.2 Post-Apartheid teacher education policies

As stated above, the new democratic dispensation had to dismantle the bastions of Apartheid in education through affirmative policies aimed at eradicating the imbalances inherent in the education system—policies that affirmed values of equity, opportunities and justice for all. Since 1994, three such landmark policies have been enacted, ensuring equal access to educational resources, learning opportunities and educational transformation.

The white papers (Government Gazette, 1995; DoE, 2001; DoE, 2004), spelt out the agenda for educational transformation, highlighting the three imperatives mentioned above: resource mobilization and re-distribution in educational institutions, the development of an inclusive curriculum, and a uniform qualifications framework to ensure justice, equity, and equal opportunities for all. It advocated setting up an integrated curriculum that espouses the values of restorative justice, equality, and human rights, while at the same time providing high quality educational content that would enable South Africa to become a competitive economy on the global stage.

While these policies levelled the playing field as far as educational resource delivery was concerned, the largest hurdle to be overcome remained that of teacher training. Successive international benchmark testing (TIMMS) carried out every 4 years (in

1999, 2003, 2007, 2011, 2015 and 2019) consistently presented South African learners between Grades 4 and 8 at the bottom of the achievement ladder in mathematics and the physical sciences. Over the years, the trend has shifted only slightly, highlighting what some researchers (e.g., Spaul, 2013) have dubbed a “crisis” in science and mathematics education. Consequently, much research has been carried out, focusing on teachers, teaching and competencies in the classroom. Over the years, two main trends have crystallized in research and intervention with regard to teachers and teaching. These are: a) studies focusing on teachers' subject matter mastery and delivery, and b) studies focusing on peripheral (but perceived fundamental) aspects of teaching, such as language and context. Both these aspects focus on the teachers' classroom practice. The underlying assumption has been that addressing the teachers' classroom practice will help teachers produce higher quality teaching.

However, despite years of concerted interventions, as the aforementioned TIMMS results demonstrated, the quality of teaching in schools has hardly improved. Clearly there still exist some barriers to achievement, despite all the progress that has been made in levelling the playing field by providing resources and equity in training facilities and opportunities to learn. Some researchers contend that the Achilles' heel of successful teaching and learning lies in how teachers are inducted into their profession (Ingersoll & Smith, 2004), besides their pedagogical content knowledge and skills. In South Africa, the regulation of teacher practices and conditions of service is carried out by the South African Council of Educators (SACE), a statutory and professional body with a mandate to (a) register educators as professionals legally working in South African schools, (b) promote the development of the teaching profession, and (c) develop, maintain and implement a professional code of ethics for all teachers registered with it. SACE has the power to sanction and suspend a teacher's membership in the event of a professional misdemeanor (Government Gazette 34620, 2011). SACE members are appointed by the Minister of Basic Education. In making this appointment, the Minister takes into consideration the educational professional expertise of the members, as well as gender, disability, race, and geographical representation. The establishment of a statutory body such as SACE places teaching on the same professional footing as law and other professions. True to its mandate, SACE has identified desirable attributes that it feels teachers should emulate in order to become proficient and successful, for example by collating research findings (Bernadine, 2019). These attributes are contained in a document called “The continuing professional teacher development (CPTD) management system” (SACE, 2013). This document was formulated in response to the gazetted policy document: “Minimum Requirements for Teacher Education Qualifications”, affectionately known as MR TEQ (DHET, 2011),



which, among other things, sought to provide a basis for the construction of core curricula for initial teacher education leading to the qualifications of professional teachers. One of the highlights of MR TEQ is its acknowledgement that successful teaching includes both contextual and situational factors. Hence, it makes teaching experience mandatory prior to qualification, ensuring that student teachers experience and handle diverse classroom and professional contexts before they graduate. In addition, the document spells out the desirable attributes that South Africans expect from the educators of their children. The South African government contended that:

- » ... the overriding aim of (teacher education) policies was to properly equip teachers to undertake their essential and demanding tasks, to enable them to continually enhance their professional competence and performance, and to raise the esteem in which they are held by the people of South Africa (DET, 2006).

It is thus argued that this development of professional efficacy should not begin only after qualification, but should instead be incorporated through induction during training.

This chapter focuses on how student teacher mentoring and supervision facilitates the development of professional efficacy in novice teachers. We strive to answer the question: in what ways does teaching experience help in professionalizing student teachers? This is achieved by scrutinizing the professional values and attributes that are reinforced through student-teacher supervision and mentorship during teaching practice. In the next section, the authors discuss the concepts of teacher efficacy and how they contribute to quality education. After this, they will outline the use of LCT (*specialization concept*) as an analysis tool for framing the development of professional knowledge among teachers.

## 2 Theoretical and conceptual background

### 2.1 Teacher professionalization as a concept

Moss (2012) describes professionalization as the process of connecting prescribed practice and procedures with expectations to meet set outcomes. Thus, professionalization is often linked to performance. However, other researchers (Mushayikwa, 2013; Griesbaber, 2017) argue that focusing only on performance demonstrates a mechanistic view of teaching as a profession and only considers its technical and ma-

nagerial aspects. The authors contend that this is far removed from the human elements of becoming a professional teacher, such as acquiring a teacher-identity, with the values, attitudes, and ethics of a successful teacher.

Mushayikwa and Lubben (2009) suggested that during the process of professionalization, a teacher needs to acquire efficacy in both performance and the affective (professional) areas of their work. Teacher efficacy may be defined as the teachers' values, beliefs and ability to effect positive student outcomes. These beliefs are dependent on the teachers' confidence and mastery of the tools of their trade. They must simultaneously develop pedagogic and managerial skills related to their classroom practice, and values and attitudes related to their unfolding identity as a teacher. These two efficacies together determine the teacher's growth and performance within the profession. Figure 1 below (Mushayikwa & Lubben, 2009) shows the relationship between classroom efficacy (performance) and professional efficacy. The diagram, presented as a model, consists of two light panels facing a translucent bulb at the center. The two panels represent the teacher's classroom efficacy (as demonstrated by the teacher's content knowledge, classroom practice skills, pedagogic knowledge, general PCK about their discipline, practical knowledge, skills and CoRes about the discipline, and topic-specific PCK within the discipline), and the teacher's professional practice (as represented by where they are in their career, the extent to which they have developed an awareness of professional ethics, the extent to which they have developed a positive professional identity, and the extent to which they have developed values to guide their practice). When the panels glow proportionally to the state of the efficacies they possess, the glow is reflected in the translucent bulb, and this in turn represents the cumulative / aggregate efficacy of the teacher at any given time.

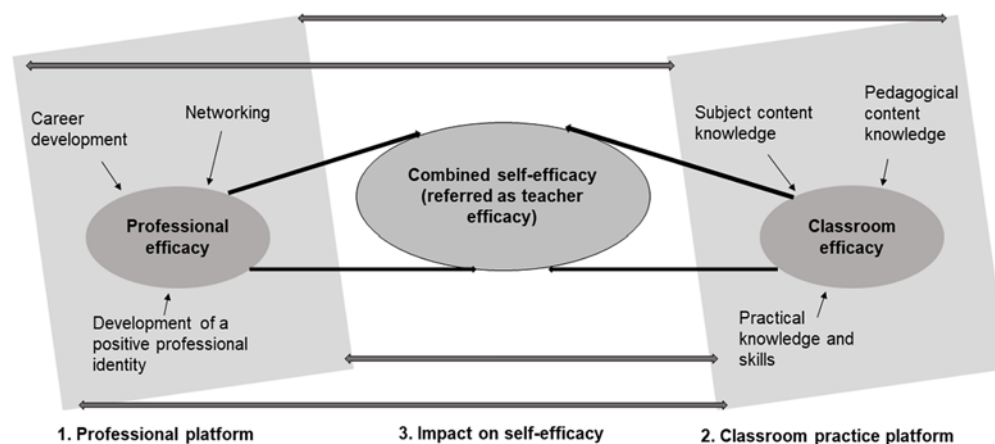

Figure 1 The teacher efficacy model (Mushayikwa & Lubben, 2009)

The model thus shows that for a teacher to develop high efficacy (high professionalization), they need to be well developed in both their classroom practice and their professional practice. This means that the two platforms need to be equally bright. The efficacy model of student and novice teacher professionalization implies that teachers need to be well coached and mentored in both professional efficacy and classroom efficacy for them to develop into highly skilled teachers. The teacher efficacy model is one way to demonstrate how the exacting standards of the South African Minimum Requirements (MR TEQ) and SACE can be met.

Ware and Kitsantas (2007) argue that teacher efficacy helps to develop teachers' belief in their ability to fit into the profession. This in turn affects their commitment to the profession: teachers who experience weak belief systems tend to have low affective commitment, which lessens their confidence in teaching and their emotional attachment to it. Thus, during TE, student teachers are expected to develop the right efficacies and attributes for commitment to the profession.

Typically, current teacher training practices focus much more on classroom practice aspects, both during content and methodology classes. It is usually assumed that the professional aspects of teaching can be acquired more easily during the teaching internship, which is typically six weeks a year over the four years. During this time, student teachers are normally assigned to a mentor teacher at the school where they teach, as well as to a supervisor from their institution. The mentor teacher inducts the student teacher into the school curriculum and both classroom and professional aspects of teaching, while the university supervisor is on hand to provide advice. However, in practice, university lecturers are inhibited in their role, as they can only visit and observe the student at work two or three times during the six weeks. In most cases, they act as advisors / guides in the first two visits, while the last visit is usually a summative assessment of the student teacher's development.

Be that as it may, efficacy research has been mired in controversy. Several researchers, for example Wheatley (2005) and Labone (2004), have argued that efficacy research is more academic than utilitarian, focusing on what teachers tell themselves they "feel" about teaching. They further argue that such perceptions of efficacy are not useful on a practical level, as teachers tend to either exaggerate or minimize their perceptions of their own effectiveness. Thus, teachers' feelings about their capabilities do not necessarily align with what they are able to do. In this chapter, the authors follow an interpretivist approach, arguing that teacher perceptions influence their decision-making. Thus, the development of teacher efficacy in teacher education can be encouraged or suppressed by the foci provided during induction.

## 2.1 Legitimation code theory

Existing research about teacher professionalism identifies specific attributes that should define a teacher. Lee Shulman (1987), for instance, highlights teachers' pedagogical reasoning and actions as integral to teachers' decision making. Pella (2015) identifies Shulman's (1987) pedagogical shifts as consisting of key pedagogical shifts, namely: (i) comprehension (that includes critical interpretation and preparation of text material); (ii) content representation (including identification of big ideas, explanations, and use of analogies); (iii) instructional selection (including teaching and learning strategies, and use of pedagogical resources such as teaching/learning aids); (iv) adaptation of content and instruction to the appropriate level of the learners. Loughran (2004) extends Shulman's findings by identifying how teachers can develop and present conceptual knowledge from one topic to another. Shulman's findings suggest that the way teachers develop and present conceptual knowledge of a specific topic varies from teacher to teacher, depending on their experience.

While extant research about teaching and learning has been published, Karl Maton (2014) proposes *Legitimation Code Theory (LCT)* as an alternative framework for exploring knowledge practices in terms of their organizing principles. Maton's argument is that the bases of achievement in any professional practice are tacit and cannot be readily discerned – therefore it is difficult to assign causation to professional practice. LCT, however, makes these bases visible by encoding the professional's behavior. By studying these codes, it is possible to determine how different behaviors enable or constrain knowledge-building in professional practice.

This chapter adopts Karl Maton's legitimation code theory (LCT) to discuss mentorship during TE regarding teacher professionalism and subject matter knowledge. Below is a brief description of LCT.

Maton (2014) defines LCT as a multidisciplinary and multidimensional theory that offers a language of description to social practice. Thus, LCT combines and extends Bourdieu and Bernstein's theories as an explanatory conceptual framework for analyzing the educational practice. While confirming the importance of acquiring a specialized gaze into educational practice as a trainee teacher (the knower-gaze), conceptions (knowledge) that validate it are also paramount (Maton, 2016). For instance, Bourdieu (2000) affirms the importance of developing a trained gaze in any practice, such as the teaching profession, stating that it requires apprenticeship in the field. Furthermore, trainee teachers' mentorship during teaching practice in schools is not linear, even with assessment rubrics. Pre-service teachers need experts' continued advice.

According to Maton, LCT comprises five different dimensions: “Autonomy, Density, Specialization, Semantics, and Temporality” (Maton, 2014, p. 18). Whilst three of these dimensions (Semantics, Specialization, and Autonomy) are well established through research, the other two (Density and Temporality) are still under development (Clarence, 2017). Although these dimensions can be used to look at a specific research situation, they provide different “gazes”. For example, the Semantics dimension looks at the abstractness and complexity of knowledge in a practice, whilst the Specialization dimension looks at the professional practice (Maton, 2014). The Specialization dimension is described in more detail below.

To track the nature of mentor-mentee apprenticeship during TE, the authors adopted the specialization dimension of LCT, which is one of its five dimensions. The specialization dimension of LCT is used to analyze and explain the nature of mentorship with regard to teacher professionalism and subject matter knowledge during TE. According to Maton (2016), the specialization dimension can be used to study any practice, such as the teaching profession, with regard to the relations between the knowledge-knower structures. The specialization codes govern the organizing principles' continuum of strength, from epistemic relations (ER) knowledge to social relations (SR) knowers. To illustrate the epistemic relations (ER) as a continuum of strength, refer to Figure 2 below.



*Figure 2 The epistemic relations (ER–/ER+)*

To illustrate the social relations (SR), which stands for the relationship between practice and its subject along a continuum of strengths, see Figure 3 below.



*Figure 3 The social relations (SR– and SR+)*

Furthermore, ER and SR continua can be brought together to illustrate a specialization plane used to describe change in practice across time (Maton, 2016).

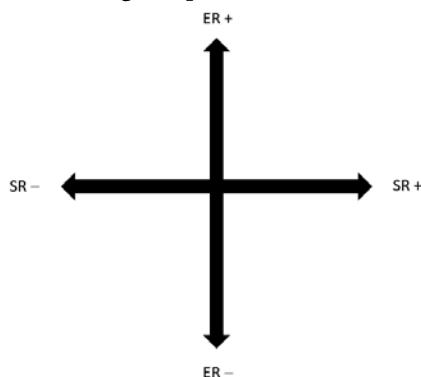

Figure 4 The specialization plane

Figure 4 below shows the specialization plane, mapping out the *knowledge code* along ER+ and SR-. For this paper, ER+, SR- will represent a strong emphasis on the *knowledge code* (classroom efficacy), which includes subject matter, knowledge of appropriate teaching strategies, and classroom control (see Martin, 2016).

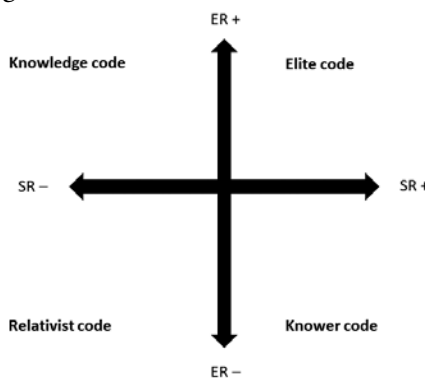

Figure 5 The specialization codes (Martin, Maton & Doran, 2019)

When the mentor emphasizes the need for professional efficacy in the comments, the *knower code* is represented by ER-, SR+.

ER-, SR- represent a *relativist code*, meaning that the legitimation here is neither knowledge nor gazes.

Lastly, the *elite code* (ER+, SR+) means that legitimacy is based on expertise in both the knowledge and the knower codes (Maton, 2014). Thus, LCT is used to encode supervisors' and mentor teachers' comments on the teaching practice experience of the stu-

dent teachers. The authors chose the specialization dimension because it enables the authors to compare the perception of the comment with its intent in terms of building up knowledge for professional practice along with the continuum level for each code.

### 3 Methodology and data analysis

The research seeks to answer the question: in what ways does teaching experience help in professionalizing student teachers? The main objective of the research was to determine the nature of the advice that university supervisors and school teachers provide student teachers with during teaching experience, as expressed in their comments after observing the students.

The authors established that the university employed a dual mentorship strategy to assist the professionalization of student teachers: a) university supervisors would visit the student at least twice while on teaching experience to provide continuing support, with the final visit usually concluded as a summative assessment for grades; and b) the university also engaged school subject teachers as mentors to the student teachers for the full duration of their teaching experience.

Four supervisors (University supervisors—US) and four mentor teachers' (school teachers—MT) assessment documents were obtained from the teaching experience archives. The archives contain hundreds of folders with teaching experience documents from past students. These folders are kept in a secure storeroom for ten years and are then destroyed. Four folders belonging to 4<sup>th</sup> year B.Ed. and PGCE Science students were selected, from archives generated between 2014 to 2018 at the university. The reason for making this selection was that both authors are familiar with the content and methodologies used in science education. It made sense to choose fields in which they know the teaching environment well. The additional criteria used in selecting specific folders were:

1. The location of the teaching experience host school—we selected schools from diverse backgrounds, including township and private schools. Two folders had documents indicating that the teaching experience had been carried out in township schools, and two in private schools. This selection was made to determine whether the host school environment had any impact on the observed trends.
2. The authors also selected folders that contained all three documents, i.e., university supervisor comments, mentor teacher comments and the student's reflective diary. This selection was made as it enabled us to collate the supervisors' comments with the student's own perceptions of what the supervisor and mentor had suggested,

giving us insight into the student's reaction to the comments. However, due to the limitations of the scope of this chapter, student teachers' reflections are not included in this discussion.

3. Folders that were isolated for potential analysis were read through to determine whether they had rich data that could be used for the purpose of this study. The analysis was more concerned with the nature of the comments than with the individual teachers, and the supervisors' / mentors' advice was classified as addressing issues of either classroom efficacy (CE) or professional efficacy (PE).

The university supervisors' and school mentors' reports were then manually and thematically analyzed using grounded theory. Ideas that recurred across each of the four document sets were identified and grouped according to either the classroom efficacy attributes or the professional efficacy attributes identified earlier. The attributes that were supported were then organized into themes. Table 1 shows the themes that emerged from this analysis.

Grounded theory analysis of the scripts yielded four recurring themes for classroom efficacy (CE) across both university supervisors and school teacher mentorship commentaries. Both groups identified: (i) Classroom management (PE1); (ii) Teacher identity development (PE2); (iii) Professional integrity (PE3). However, only the school teachers identified Administration (PE4) as a theme in the classroom. Table 1 provides details of the descriptors for professional efficacy, as arising from the commentaries of the university supervisors and mentor teachers.

	<b>Classroom efficacy</b>	<b>Professional efficacy</b>
<b>University supervisor themes</b>	Comprehension: critical interpretation, and preparation of text. CE <sub>1</sub>	Classroom management: use of time, pacing, planning, discipline (noise control), and reflectivity. PE <sub>1</sub>
	Content representation: identifying big ideas, explanations, and analogies. CE <sub>2</sub>	Identity development: motivation, and attitude towards learners (e.g., knowing learners by name). PE <sub>2</sub>
	Instructional selection: teaching/learning strategies, pedagogical resources e.g., L/T aids, and feedback. CE <sub>3</sub>	Professional Integrity: ethics, attitude towards work etc. PE <sub>3</sub>
	Adaptation: of content to learners' level and learners' needs. CE <sub>4</sub>	



<b>School mentor teacher themes</b>	Comprehension: critical interpretation, and preparation of text. CE <sub>1</sub>	Classroom management: use of time, pacing, planning, discipline (noise control), and reflectivity. PE <sub>1</sub>
	Content representation: identifying big ideas, explanations, and analogies. CE <sub>2</sub>	Identity development: motivation, and attitude towards learners (e.g., knowing learners by name). PE <sub>2</sub>
	Instructional selection: teaching / learning strategies, pedagogical resources e.g., L/T aids, and feedback. CE <sub>3</sub>	Professional Integrity ethics, attitude towards work (punctuality). PE <sub>3</sub>
	Adaptation: of content to learners' level and learner needs. CE <sub>4</sub>	Administration: recordkeeping, registers, mark lists, and reports. PE <sub>4</sub>

*Table 1 Themes identified from document analysis of university supervisors*

Maton (2016) argues that in order to make sense of the themes emerging from the grounded theory analysis, an external language of description must be developed to interpret the thematic analysis. Such a language of description is called a translation device. A translation device is a tool [an external language] used to interpret the typologies or the thematic analysis. Research that used Bernstein's (1977) theory of classification and framing coined the notion of translation device from the external languages: here, classification deals with the strength of boundaries between contexts and categories, while framing refers to the strength of control within the contexts or the categories (Muller, Davies & Morais, 2004).

In this chapter, two translation devices were used to discuss weak and strong epistemic relations (ER) and social relations (SR), respectively. This was done to discuss the supervision and mentorship of student teachers during TE in terms of classroom efficacy and professional efficacy from the university supervisors' and school-based mentors' perspectives. The specialization dimension and its concepts have been widely used to understand different practices, such as educational practice. Maton and Chen (2016) used LCT's specialization dimension to analyze the curriculum, pedagogy, and assessments in terms of strong and weak ER and SR. Langsford (2020) also used the specialization dimension and its concepts to analyze the pedagogical reasoning of pre-service teachers who used different pathways to become teachers.

Table 2 shows the translation device developed for the university supervisors' comments. It shows the supervisors' comments as raw data from the selected sample, illustrating how the translation device was constructed. The four university supervisors

were coded as US1 through to US4. Similarly, Table 3 shows the translation device used to code the school teachers' comments. The four mentor teachers (school teachers) were coded as MT1 through to MT4.

<b>Epistemic Relations (ER)</b>		
<b>Concepts demonstrated emphasizing:</b>	<b>Indicator</b>	<b>Examples using excerpts from data</b>
Classroom efficacy (ER+)	When classroom efficacy is emphasized as the authentic form of knowledge during mentorship	<i>You need to demonstrate that you are aware of misconceptions that may arise in the content. These may be misconceptions that learners bring from home, from their everyday interactions or from their understanding of the content knowledge. You need to show how you will tease out these misconceptions and how you will address them. I liked that you incorporated the lesson evaluation aspect that we discussed last time I was here. (US1)</i>
Classroom efficacy (ER-)	When classroom efficacy is suppressed as less important during TE mentorship	<i>You tend to talk too much, and you introduced too many new terms all at once; for example, mole concept, relative atomic mass, each of these is a lesson in its own right. (US1)</i>
Professional efficacy (ER+)	When professional efficacy is emphasized as authentic during TE mentorship	<i>The lesson plan was well written, with detailed objectives, prior knowledge of learners, and lesson sequence written in steps. (US2)</i>
Professional efficacy (ER-)	When professional efficacy is suppressed and downplayed during TE mentorship	<i>It would help if you were more assertive and confident in your presentation. (US4)</i>
<b>Social Relations (SR)</b>		
<b>Concepts demonstrated emphasizing:</b>	<b>Indicator</b>	<b>Example with excerpts from data</b>
<b>SR+</b>	When classroom efficacy is explicitly emphasized based on opinions and personal experiences.	<i>Asking learners to work in groups to demonstrate oil floating and chalk sinking was a better option than the teacher using a simple small beaker. (US2)</i>
<b>SR-</b>	When personal experiences and opinions about classroom efficacy are downplayed during teaching experience mentorship	<i>... , but I still feel that the student plans less work for the lesson. Please minimize the use of "I will...; I will... let the learners take a major role in their learning." Give them tasks to do in groups, for, say, 10 mins, followed by class discussion. (US2)</i>
<b>Professional efficacy SR+</b>	When professional efficacy is explicitly emphasized based on personal experiences and opinions	<i>Good classroom management. Learners were busy throughout the lesson. (US3)</i>

<b>Professional efficacy SR-</b>	When opinions and personal experiences downplay the professional efficacy	<i>I feel that this lesson did not have much content to cover. You could have covered more work. (US<sub>3</sub>)</i>
----------------------------------	---	---

Table 2 The translation device using LCT's specialization dimension for discussing university lecturers' (US) mentorship

<b>Epistemic Relations (ER)</b>		
<b>Concepts demonstrated emphasizing:</b>	<b>Indicator</b>	<b>Examples using excerpts from data</b>
<b>Classroom efficacy (ER+)</b>	When classroom efficacy is emphasized as the authentic form of knowledge during teaching experience mentorship	<i>Topic: Concentration The lesson was well executed. Definition clearly explained through representation. The formula was also explained with emphasis on the units of concentration. (MT<sub>1</sub>)</i>
<b>Classroom efficacy (ER-)</b>	When classroom efficacy is suppressed as less important during teaching experience mentorship	<i>Class worked and followed the lesson along. No doubt the student teacher had taken her time planning and preparing for this lesson. (MT<sub>1</sub>)</i>
<b>Professional efficacy (ER+)</b>	When professional efficacy is emphasized as authentic during teaching experience mentorship	<i>Educator was professional in approach and has the potential to be a good teacher. (MT<sub>2</sub>)</i>
<b>Professional efficacy (ER-)</b>	When professional efficacy is suppressed and downplayed during teaching experience mentorship	<i>Don't allow girls to go to the toilet unaccompanied. (MT<sub>4</sub>)</i>
<b>Social Relations (SR)</b>		
<b>Concepts demonstrated emphasizing:</b>	<b>Indicator</b>	<b>Example with excerpts from data</b>
<b>SR+</b>	When classroom efficacy is explicitly emphasized based on personal experiences and opinions	<i>Good that you went through common mistakes that learners made in the test. (MT<sub>3</sub>)</i>
<b>SR-</b>	When personal experiences and opinions about classroom efficacy are downplayed	<i>Good to practice conversions. (MT<sub>3</sub>)</i>
<b>Professional efficacy SR+</b>	When professional efficacy is explicitly emphasized based on personal experiences and opinions	<i>Good blackboard use and clear handwriting. (MT<sub>4</sub>)</i>
<b>SR-</b>	When professional efficacy is downplayed based on personal experiences and opinions	<i>Can cope with class when left alone. (MT<sub>4</sub>)</i>

Table 3 Translation device for discussing mentor-teachers' (MT) comments

These comments were also compared with the student teachers' reactions to the lesson observations, as reflected in their journals. The LCT analysis enabled the authors to get a sense of the efficacy bias of the supervisors and mentors, as well as to determine whether the comments generated would be deemed useful in developing efficacy in the professionalization of the student teacher.

#### 4 Analysis and discussion

In the discussion, LCT's specialization dimension is used to understand the mentorship of university supervisors and school teacher mentors in terms of how they understand the teaching profession as a practice. In Figure 3 above, the knowledge codes ER+ and SR- answer questions about what you know, whereas the knower codes ER-; SR+; answer questions relating to the knower under the specialization dimension (Martin, Maton & Doran, 2019).

##### 4.1 University supervision reports

The university supervisors legitimized the knowledge code (ER+ / SR-) of pre-service teachers, as demonstrated by the discussion below. Their reports focused on the following aspects of knowledge: relevant activities; what knowledge the mentee planned to teach; the way the topic was introduced; the nature of the teaching strategies adopted; and the interactions between the pre-service teacher and the learners. These aspects of knowledge were exemplified in the comments made by the supervisors in the written reports.

Caveat 1: Comprehension (CE1)

For example, in a report on the teaching of a Grade 10 lesson on chemical change, the lecturer US3 commented:

- » Your lesson plan is incomplete. There are several sections that are missing from your plan, (please refer to the TE booklet), each lesson should reflect what the learners are expected to know (content knowledge), be able to do (skills), and understand (attitudes and values). These three important areas are missing from your plan. [US3] (ER+, SR-) CE1

The comment above legitimizes the knowledge code. It emphasizes what the supervisor considers as the authentic knowledge that the student teacher should have ap-

plied. Thus, the epistemic relations score is strong (ER+), but the social relations score is weak (SR-), which is why this comment is coded in the upper left quadrant of Figure 6 below.

#### Caveat 2: Treatment of misconceptions

- » You need to demonstrate that you are aware of misconceptions that may arise in the content. These may be misconceptions that learners bring from home, from their everyday interactions or from their understanding of the content knowledge. You need to show how you will tease out these misconceptions and how you will address them. [US<sub>1</sub>] (**ER+** **SR-**) CE<sub>2</sub>

The comment above authenticates the knowledge code by reminding the PST to take note of the content knowledge vis-à-vis what learners know and the misconceptions they may harbor. Using the concept of teacher's pedagogical reasoning and action according to Shulman (1987) and Pella (2015), the student teacher is reminded to think and plan with essential science ideas in order to keep in mind the judgement of what learners know, and what the teacher wants them to know, considering effective strategies as well as difficulties in teaching the concept (Loughran, Mulhall & Berry, 2004). Again, in this caveat we find that the emphasis is on the content knowledge dimension, so the comment is encoded in the upper left quadrant (see Figure 6).

#### Caveat 3: Affective

- » I liked that you incorporated the lesson evaluation aspect that we discussed last time I was here. [US<sub>1</sub>] (**ER-**/**SR+**) PE<sub>3</sub>

In this case, the supervisor affirms appreciation and provides positive feedback, which helps to strengthen the student teacher. This represents a professional emphasis and positive reinforcement of what is expected of the student teacher. This affirmation statement authenticates the knower code. The lecturer follows up on previous visits' recommendations to make sure that the student teacher has implemented them. The emphasis here is on professional growth.

#### Caveat 4: Holistic lesson evaluation

- » You started well recapping on the baseline assessment and introducing the mole concept. However, you took too much time on the introduction. [**ER-**, **SR+** (CE<sub>1</sub>)]

- » It would help if you were more assertive and confident in your presentation. [**ER-**, **SR+** (PE<sub>3</sub>)] You tend to talk too much, and you introduced too many new terms all at once; for example, mole concept, relative atomic mass, each of these is a lesson in its own right. [**ER-**, **SR+** (CE<sub>1</sub>)]
- » It looks like you were not well-prepared for this lesson. [**ER-**, **SR+** (PE<sub>1</sub>)] You kept on making small mistakes. You did not indicate, for example, why you have atomic mass and relative atomic mass. You did not explain the foundations for these. [**ER+**, **SR+** (CE<sub>1</sub>)]
- » This Periodic Table can be wrong—you need to talk about isotopes and how they (relative atomic masses) are derived from the isotopes. [**ER-**, **SR+** (CE<sub>1</sub>)]
- » This lesson was a disaster; you need to come prepared to teach. [**ER-**, **SR+** (PE<sub>1</sub>)]
- » You say RAM has no units, but the atomic mass has units. What are the units of atomic mass? [**ER+**, **SR-** (CE<sub>1</sub>)]
- » 1 amu is equal to  $\frac{1}{12}$  of C-12 atom, so the formula for relative atomic mass is 1 amu or  $\frac{1}{12} \times 12 \times$  the element. [**ER+**, **SR+** (CE<sub>1</sub>)]
- » Atomic mass is equal to the number of protons and neutrons in the nucleus. Therefore, atomic mass is a whole number. [US<sub>2</sub>] [**ER+**, **SR+** (CE<sub>1</sub>)]

In this caveat, the university supervisor's comments are distributed between knowledge, knower, and elite codes (see Figure 4a below). The university supervisor details the lesson process by indicating to the student teacher what they did well. For instance, a baseline assessment is vital in tying the previous lesson into the day's lesson topic. This enhances the student teacher's comprehension of their role as a teacher. The US also advises the student teacher to be more assertive in explaining the concept and in engaging learners. This caveat addresses all critical aspects of the teaching profession as explained above, namely classroom efficacy (comprehension, content representation, instructional selection, and adaptation) and professional efficacy (classroom management, professional identity, professional integrity, and administration). Therefore, the lecturer is not only judging the student teacher to be knowledgeable in terms of subject matter knowledge, but

also furnishing them with the right kind of knower code to become an elite teacher (Figure 4a below, upper right quadrant). They even advise the student teacher not to take things for granted when they warn the student teacher that “the Periodic Table can be wrong—you need to talk about isotopes and how they are derived from the elements.”

The above caveat affirms that the supervisor mentors the pre-service teacher to know more than what the learner textbook provides, thus training the student teacher to excel and become an expert teacher in the field *elite code*. The supervisor concerned dissects the lesson process to guide the student teacher on what it takes to become a teacher.

Caveat 5: Content representation

- » You should have provided the learners with more and varied examples similar to the ones given in their textbooks to help them master the idea of relativity before moving onto the relative molecular mass. [US4] (ER+ / SR-) CE<sub>2</sub>

Lastly, the mentorship provided to the ST aims at developing their classroom efficacy. Through the guidance given, the ST in question is inducted into what the topic entails, i.e., the teacher's PCK (Loughran, 2006).

However, it should be mentioned that most of the university supervisors were writing in the third person in their mentorship reports. Rather than addressing the student teacher, they became reports *about* the student teacher. The impersonal nature of the reporting gives the impression that these reports were not meant to build up the students, but rather to report on them—as in a summative evaluation. The authors believe that this kind of supervision had an impact on the student teacher's view of the supervision process.

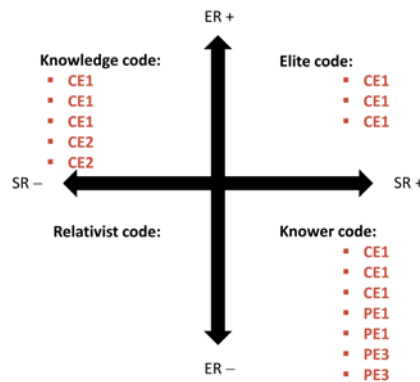

Figure 6 University lecturers: mapping of specialization codes

Figure 6 shows how the four university supervisors' comments are mapped to reflect the specialization codes. The distribution of the codes reflects an emphasis on knower and knowledge aspects of specialization, wherein the knower aspects of specialization are more instructional. One of the supervisors' comments are distributed across three of the domains/quadrants, with comments ranging from highly specific to balanced advice (elite code) through the knowledge and knower domains.

#### 4.2 Mentor teacher reports

Now a discussion about the nature of the schoolteachers' mentorship reports ensues. Caveat 1: Time-keeping

- » Arriving on time is very important! You must be here to greet them! Create your atmosphere and your own discipline. [MT<sub>1</sub>] (**ER-**, **SR+**) **PE<sub>3</sub>**

The mentor teacher's comments show that he was more concerned with the student teacher's professional behavior and projected image. Thus, these comments were aimed at motivating the student teacher to develop professional ethics, which is an important part of developing a professional identity. The reported statement emphasizes strong social relations, but a suppressed epistemological relationship.

Caveat 2: The lesson process

- » The lesson was well executed [**ER-**, **SR-** (PE<sub>1</sub>)]. The definition clearly explained through representation. The formula was also explained with emphasis on the units of concentration [**ER+**, **SR-** (CE<sub>2</sub>)]. The preservice teacher engaged learners by asking some of them to write on the board when answering homework questions [**ER-**, **SR+** (CE<sub>3</sub>)]. The class worked and followed the lesson along. [MT<sub>4</sub>] (**ER-**, **SR-**) **PE<sub>1</sub>**

Some parts of this mentor teacher's report are explicit, though there are also generalized evaluative statements. These reports were meant to benefit the student teacher, but the way this report was written indicates that it was directed at the assessors, rather than at the student. There is a sense of finality in the writing style. Although the mentor teacher touches on both classroom efficacy and professional efficacy aspects, the knowledge is suppressed.



### Caveat 3: Classroom advice

- » Madam, “I don't know” can be broken down into questions. [MT<sub>1</sub>] (**ER-**, **SR+**) **CE<sub>3</sub>**

This teacher presented more general comments. However, the comment that stood out was the one above. This is because it emphasizes knowledge of learners and contexts. What the teacher means is that if learners say they do not know something, the teacher must break down the question into further simpler questions. Hence, this was classified as revealing the knower code.

### Caveat 4: Classroom management

- » When a girl is busy on the board, think of a way to involve the whole class. Sometimes the girls (girl's) confusion can lead to disruption, ask for hands [MT<sub>3</sub>] [**ER-**, **SR+** (PE<sub>1</sub>)].

In this comment, the mentor teacher was emphasizing classroom management, advising the student on strategies for keeping the class focused. This kind of knowledge helps the student teacher acquire a deeper understanding of the learners and of learning behavior. For this reason, we classified the comment as being in the knower quadrant. See Figure 7 below.

### Caveat 5: Classroom management

- » Weird things do happen in class, draw attention of the learners to you. The back of the class is disruptive, so you must settle the class before carrying on. Don't be afraid to single out bad behavior but be wary of distracting from the lesson. [MT<sub>4</sub>] [**ER-**, **SR+** (PE<sub>1</sub>)].

In this comment, the mentor teacher was emphasizing the maintenance of discipline in class. The emphasis is once again greater in the social relations and suppressed in the knowledge domains. Thus, this comment is more focused on professional efficacy.

### Caveat 6: Contextually bound classroom management

- » Girls forget. (They) don't always work. Give spot tests. But be careful with frustration. Class clowns like to catch out the teacher. [MT<sub>3</sub>] [**ER-**, **SR-** (PE<sub>1</sub>)]

This comment by a mentor teacher at a girls' high school was focused on classroom management that is contextually bound. The advice is relational, as it applies to generalized classroom management in a specific context. Therefore, this comment is coded “relativist”, i.e., the bottom left quadrant in Figure 4b. The insight generated in this context is focused on professional efficacy, as it deals with being aware of the context in which the teacher is working.

Caveat 7: Girl-child protection

- » Make sure you have a list of the girls who are staying on after school. The rule is that the girls need to give 24hrs notice if they are going to stay behind after school. [MT<sub>3</sub>] [ER<sup>-</sup>, SR<sup>-</sup> (PE<sub>4</sub>)]

The advice is relational, as it applies to generalized classroom management in a specific context. This comment is therefore coded as “relativist”, i.e., the bottom left quadrant in Figure 4b. The comment is meant to sensitize the teacher to the need to protect the girl child and thus speaks to the ethical role of the teacher as a guardian in loco parentis.

Caveat 8: Content knowledge

- » Please make sure to use molar mass all the time when explaining and calculating. Never use mass. Mass is different and will confuse the learners. [MT<sub>2</sub>] [ER<sup>+</sup>, SR<sup>+</sup> (CE<sub>3</sub>)]

This is a precise instruction to make sure that the student teacher gets their content knowledge right. Therefore, it falls in the epistemic relations knowledge quadrant (top left in Figure 4b).

Caveat 9: Pacing

- » Marking homework is taking too long. You can give a memo to the learners to mark during break time before coming to class. They then can just ask what they do not understand. You are too slow. You need to move faster with the curriculum. [MT<sub>2</sub>] [ER<sup>-</sup>, SR<sup>+</sup> (PE<sub>3</sub>)]

In this comment, the mentor teacher was admonishing the student teacher for moving at a slow pace and using strategies that waste time. The mentor then suggested better, more efficient methods. This increases the “knower” code for the student teacher and speaks to their professional efficacy through an increased awareness of professional ethics.

### Caveat 10: Content knowledge

- » Careful with the use of the word “atom”. Don't use “one atom” of sulphate! There are 5 atoms in  $-SO_4$  but 1 set of an ion of sulphate! [MT<sub>2</sub>] [ER+, SR+ (CE<sub>3</sub>)]

This comment focuses on accuracy in techno-scientific language to avoid misconceptions. It is therefore coded in the top right quadrant, as it emphasizes specific epistemological relations and helps develop the student teacher's classroom efficacy and professional efficacy.

Figure 7 shows how the four mentor teachers' reports are mapped to reflect the specialization codes. See Figure 7 below.

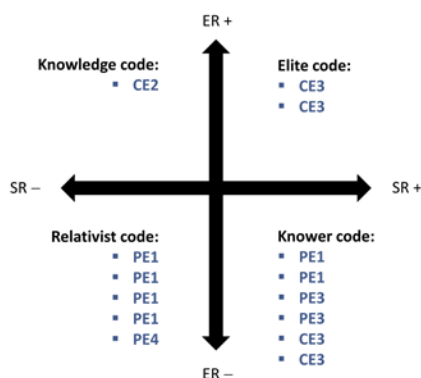

Figure 7 Mentor teachers: mapping of specialization codes

The remarks made are mainly from the knower code (ER-, SR+), the bottom-right quadrant in Figure 7 above. The code's distribution shows that the majority of the mentor teachers' concerns were more about developing the student teachers as knowers. The advice provided in the reports was of a practical nature and focused mainly on classroom / ethical behaviors, focusing on learner management, time management and pacing. Mentor teachers also made generalized comments.

Figure 8 provides combined specialization codes for the university supervisors and mentor teachers. The school mentors concentrated on professional efficacy in their reports, which varied depending on the school context. Their main emphasis was on classroom management and professional integrity. The mentor teachers paid attention to contextualized administration issues. For example, one mentor teacher's report from a girls-only school addressed issues of being early to school to set the day's atmosphere with learners. The mentor teacher then comments at length about not allowing girls to leave class. In general, all four mentor teachers provided very specific com-

ments that would fall in the relativist code, in the bottom left quadrant. The comments were more contextualized to the school culture.

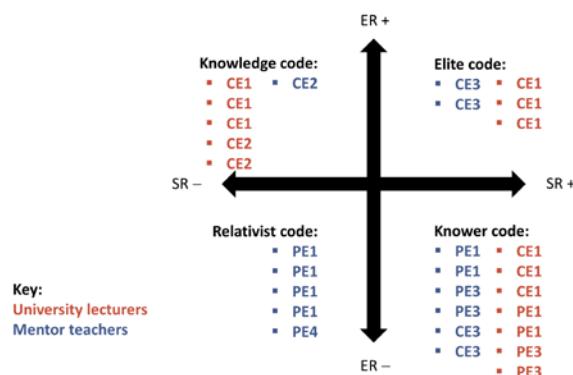

Figure 8 Combined specialization codes for university and mentor teachers

On the other hand, the university supervisors' comments revealed a strong focus on the student teacher's content knowledge. For example, in Table 2, the statement focuses the student teacher's attention on pedagogical knowledge necessary for classroom efficacy:

- » You need to demonstrate that you are aware of misconceptions that may arise in the content. These may be misconceptions that learners bring from home, from their everyday interactions or from their understanding of the content knowledge. You need to show how you will tease out these misconceptions and how you will address them. I liked that you incorporated the lesson evaluation aspect that we discussed last time I was here. (UL1)

As demonstrated in Figure 5, some of the comments by the university lecturers covered all quadrants, including the elite specialization codes, indicating strong grounding in both professional and classroom efficacies.

MR TEQ lays down minimum requirements for teacher education qualifications and specifies that student teachers should spend a total of two semesters in the schools during the four years of their education. This is to ensure that student teachers acquire practical teaching experience and develop both professional and classroom efficacies by the time they qualify. The findings of this chapter reveal a synergy between university and school-level expectations of the knowledge that student teachers are supposed to bring with them to the schools. For instance, university supervisors' reports

tended to focus on the knower, knowledge, and elite codes from the quadrants above, which are more theory-based, while the mentor teachers' reports tended to refer to all four quadrants, making their mentoring style more practical and contextualized.

## 5 Conclusions and recommendations

In this chapter, the authors sought to describe and analyze how student teacher mentoring and supervision facilitate the development of teacher efficacy in novice teachers. The study revealed that student teacher supervision and mentoring covered both professional and classroom efficacies. The foci and manner of presentation were also found to be cumulative. However, the mentoring and supervision reports were found to be oriented towards summative evaluation, when in fact they were meant to be developmental. It is therefore necessary that both the supervisors and mentors agree on the supervision process and address the student teacher to show them that supervision and mentoring are meant to help them become better teachers. The study showed that there is a synergy in the co-operation between the mentor teachers and the university supervisors, which ensures the development of professional values and rigor during the teaching experience supervision process.

### Literature

- African National Congress (1994). *A Policy Framework for Education and Training* ANC Education Department.
- Bengu, S. M. E. (1998). Developments in education since 1994: Our current challenges and plans for the future. In *Report of the National Policy Review Conference on Education and Training 1998* (pp. 29–38). University of the Witwatersrand.
- Bernadine, G. G. K. (2019). Challenges faced by educators in the implementation of Continuing Professional Teacher Development (CPTD): In Monyai, Reginald Botshabeng (Ed.), *Teacher Education in the 21<sup>st</sup> century*. IntechOpen.
- Bourdieu, P. (1999). Social space and symbolic power. *Sociological Theory*, 7(1), 14–25.
- Clarence, S. (2017). Knowledge and knowers in teaching and learning: An enhanced approach to curriculum alignment. *Journal of Education*(66), 65–84.
- Department of Basic Education. (2011). *Curriculum and assessment policy statement, grades 10–12 (CAPS) Physical Sciences*. Government printers.
- Department of Education (1995a). Education and training in a democratic South Africa: First steps to develop a new system. White Paper on Education and Training. Notice 196 of 1995. *Government Gazette Staatskoerant*, vol. 153, No. 16312. 1995.
- Department of Education (2000). Norms and standards for educators. National Education Policy Act No. 27 of 1996. *Government Gazette Staatskoerant*, vol. 415, No. 20844. 2000.
- Department of Higher Education and Training (DoE) (2007a). The minimum requirements for teacher education qualifications. *Government Gazette Staatskoerant*, No. 34467. 2011.
- Glickman, C. D., Gordon, S. P., & Ross-Gordon, J. M. (2014). *Supervision and instructional leadership. A developmental approach* (9<sup>th</sup> ed.). Pearson Education.
- Heeralal, P. J., & Bayaga, A. (2011). Pre-service teachers' experiences of teaching practice: case of South African University. *Journal of Social Sciences*, 28(2), 99–105.

- Jansen, J. D. (2004). Autonomy and accountability in the regulation of the teaching profession: A South African case study. *Research Papers in Education*, 19(1), 51–66. <https://doi.org/10.1080/0267152032000176972>
- Kimathi, F., & Rusznyak, L. (2018). Advancing professional teaching in South Africa: Lessons learnt from policy frameworks that have regulated teachers' work. *Education as Change*, 22(3), 1–25.
- Labone, E. (2004). Teacher efficacy: Maturing the construct through research in alternative paradigms. *Teaching and teacher education*, 20(4), 341–359.
- Langsford, D. (2020). 'Those who can think, Teach,' The pedagogical reasoning of pre-service teachers from different initial teacher education pathways. (Unpublished doctoral dissertation). Witwatersrand.
- Leonardo, Z. (2004). Critical social theory and transformative knowledge: The functions of criticism in quality education. *Educational Researcher*, 33(6), 11–18.
- Li, M., Fox, J., & Grieshaber, S. (2017). *Contemporary issues and challenge in early childhood education in the Asia-Pacific region*. Springer Singapore.
- Loughran, J., Mulhall, P., & Berry, A. (2004). In search of pedagogical content knowledge in Science: Developing ways of articulating and documenting professional practice. *Journal of Research in Science in Science Teaching*, 41(4), 370–391.
- Loughran, J. (2006). *Developing a pedagogy of teacher education: Understanding teaching and learning about teaching*. Taylor & Francis.
- Maodzwa–Taruvinga, M., & Cross, M. (2012). Jonathan Jansen and the curriculum debate in South Africa: An essay review of Jansen's writings between 1999 and 2009. *Curriculum Inquiry*, 42(1), 126–152.
- Martin, J. L. (2016). Musicality and musicianship: Specialisation in jazz studies. In K. Maton, S. Hood & S. Shay (Eds.), *Knowledge-building: educational studies in Legitimation Code Theory* (pp.193–213). Routledge.
- Martin, J. R., Maton, K., & Doran, Y. J. (2019). *Accessing academic discourse: Systemic functional linguistics and legitimation code theory*. Routledge.
- Maton, K. (2014). A TALL order? Legitimation code theory for academic language and learning. *Journal of Academic Language and Learning*, 8(3), A34–A48.
- Maton, K., & Chen, R. T. H. (2017). Specialization from legitimation code theory: How the basis of achievement shapes student success. In J. R. Martin, K. Maton, Wang Pin & Wang Zhenhua (Eds.), *Understanding Academic Discourse*. Higher Education Press.
- Moss, J. (2012). Teachers learning in community: Realms and possibilities. *Teaching Education*, 23(1), 111–113. <https://doi.org/10.1080/10476210.2012.651960>
- Msibi, T., & Mchunu, S. (2013). The knot of curriculum and teacher professionalism in post-apartheid South Africa. *Education as Change*, 17(1), 19–35.
- Muller, J., Davies, B., & Morais, A. (2004). *Reading Bernstein, researching Bernstein*. Routledge Falmer.
- Ogunniyi, M. B., & Mushayikwa, E. (2015). Teacher education in South Africa: Issues and challenges. *Teacher Education Systems in Africa in the Digital Era*, 71.
- Heeralal, P. J., & Bayaga, A. (2011). Pre-service teachers' experiences of teaching practice: Case of South African university. *Journal of Social Sciences*, 28(2), 99–105. <https://doi.org/10.1080/09718923.2011.11892933>
- Reddy, V., Prinsloo, C., Arends, F., Visser, M., Winnaar, L., Feza, N., ... & Maja, M. (2012). *Highlights from TIMSS 2011: The South African perspective*. Department of Basic Education South Africa.
- Shulman, L. S. (1987). Knowledge and teaching: Foundations of the new reform. In D. Hartley & M. Whitehead (Eds.), *Teacher Education. Major Themes in Education*, Volume III Curriculum and Change (pp. 119–145). Routledge.
- South African Council for Educators (SACE) (2002). *Handbook for the code of professional ethics*. Scottsville Unilever Ethics Centre and the University of Natal.
- South African Council of Educators (SACE) (2009). *The code of professional ethics (as amended)*.
- Spaull, N. (2013). South Africa's education crisis: The quality of education in South Africa 1994–2011. Johannesburg Centre for Development and Enterprise.
- Ware, H., & Kitsantas, A. (2007). Teacher and collective efficacy beliefs as predictors of professional commitment. *Journal of Educational Research*, 100(5), 303–310. <https://doi.org/10.3200/JOER.100.5.303-310>.
- Wheatley, K. F. (2005). The case for reconceptualizing teacher efficacy research. *Teaching and Teacher Education*, 21(7), 747–766.



**Pedagogical Content Knowledge  
in Higher Education Teaching and Learning Processes**

| 3





## Chapter 8

# Investigating Abstractness and Motivation as Scaffolding Elements in Biology Lesson Planning. An Explorative Study.

Eunice Nyamupangedengu and Christoph Randler

*In this chapter, we focus on lesson planning as one general competence that the biology education program at the University of Tübingen in Germany and the South African University of the Witwatersrand's School of Education (WSoE) aim to develop in teaching students. We first provide an overview of biology teacher education at Wits and Tübingen. We then present a case study in which teaching methods based on the cone of learning and practical teaching methods at Tübingen University are implemented for the school topic 'ecology and evolution'. We provide the results of a lesson plan analysis, showing that only about half of the students at Tübingen University were able to apply the knowledge from the introductory lecture to their practical lesson plans. Using the cone of learning helps to show the kinds of representation chosen by the students, but does not illuminate teaching students' pedagogical reasoning for the choice of representations. Because of this, the study recommends a mixed method approach, in which the analysis of lesson plans using the cone of learning is followed by the interviewing of the teaching students.*

### 1 Introduction

“Failing to plan is planning to fail” is an age-old adage that highlights the importance of planning in life. Even in education, lesson planning is considered to be central to good teaching and is a core activity in schools (Kosnick & Beck, 2009). Because of its

<http://dx.doi.org/10.15496/publikation-76374>



importance, preparing student teachers to plan instruction that meets the learning needs of their pupils is one goal of teacher education programs (Rusznyak & Walton, 2011). Teaching student teachers how to create lesson plans is therefore one of the key activities in pre-service teacher education (Kosnick & Beck, 2009; John, 2006). While the importance of lesson planning is widely recognized, research shows that effective lesson planning is a significant challenge for pre-service teachers (Derri, Papamitrou, Vernadakis & Koufou, 2014). One reason for this is the inability of teacher educators to strike a balance between providing lesson plan guidelines that can easily be used by student teachers while preserving what Rusznyak and Walton (2011, p. 272) describe as “the complexity that reveals the inner logic of lesson coherence”. According to Rusznyak and Walton (2011), one way of overcoming this challenge is by scaffolding the student teachers' development of lesson-planning skills. This suggestion, however, raises the question of how that scaffolding can be achieved. In this collaborative research, the authors analyzed teaching students' lesson plans at Tübingen University to determine the effectiveness of the concepts of the cone of learning and biologically relevant methods as scaffolding tools for developing teaching students' ability to prepare effective lesson plans, drawing on insights from WSoE experiences in which a specific framework was used. Effective lesson plans were taken to be those that reflect not only aspects of good teaching, as outlined by the cone of learning and the biologically relevant methods, but also coherent pedagogical reasoning (Bishop & Denley, 2007) about the choice of instruction. Through document analysis, the basic ideas of biology teaching that manifested in the lesson plans were compared with what was taught by the educators and discussed in relation to the lesson planning approaches used at the University of the Witwatersrand's School of Education (WSoE). The questions that guided this study were:

1. How do the concepts of the cone of learning and of biologically relevant methods used in the Tübingen Biology Education Department support the scaffolding of lesson planning?
2. How do the concepts of the cone of learning and of biologically relevant methods used in Tübingen relate to the TSPCK framework used in the WSoE?

## **2 Context of the study: An overview of biology teacher education at Wits and Tübingen**

The teacher education program at WSoE is made up of four streams: the academic stream, which covers the teaching of disciplinary content subjects, such as mathema-

tics, science, geography and English; the core subjects stream, which consists of the philosophy, psychology and sociology of education; the pedagogical stream, which covers courses on teaching methods referred to simply as methods courses; and the Teaching Experience stream. In the content stream, pre-service teachers are taught subject-specific knowledge. In the core subject stream, they are taught about education and its foundations and theories. In the methods courses, they are taught how to teach a specific content subject. Lastly, in the Teaching Experience stream, students are placed in schools to practice teaching (for further details on the program, see Nyamupangedengu, 2016 and Mavhunga & Rollnick, 2017). In the Division of Science Education, the pedagogical stream, i.e., the teaching of the methods courses, is guided by a pedagogical content knowledge framework called the Topic Specific Pedagogical Content Knowledge (TSPCK) framework.

There are several similarities between the WSoE and the TüSE. Similar to the WSoE's first stream, Tübingen has a strong foundation in the content subjects. Unlike at the WSoE, this content is taught separately from biological education teaching, but with overlap in some topics, such as ecology and evolution. Furthermore, a second column consists of core subjects such as the philosophy, psychology and sociology of education. The TüSE's third stream is made up of "Fachdidaktik", a term rather difficult to translate, as it refers to teaching a specific subject. Fachdidaktik combines methodological questions with subject-specific content.

To illustrate this: the topic of animal ecology is related to the content stream at the WSoE, while topics like classroom management or optimal group size are related to the core subjects stream. However, Fachdidaktik is about the teaching of specific content that is not taught in other streams. Microscopy or observation of living animals, for instance, are rarely taught in other subjects. These courses are partly comparable between both universities because they link scientific content with practical teaching. An example is "biology lessons planning", in which different methods are taught. Thus, the subject courses for biology teaching students are similar to Bachelor of Science courses in terms of biological content. However, the methodology is different for biology teaching students' courses, and teaching students receive additional courses in biology teaching methods and didactical aspects.

Other science subjects also differ in content and subject-specific teaching, while all teaching students experience more or less similar courses in education sciences. As in the fourth stream, the TüSE also has mandatory teaching experience, which is, however, placed in the master's program. It comprises about 16 weeks of teaching in regular schools and is supervised by teachers.

## 2.1 Literature review and the analytical framework for the study

As indicated in the context section above, the teaching of biology methodology courses at the WSoE is guided by the TSPCK framework. In 2009, Shen, Poppink, Cui and Fan identified pedagogical content knowledge (PCK) as knowledge that teachers need in order to plan effective lessons. PCK was defined by Shulman as a special amalgam of content and pedagogy needed for teaching the subject. Shulman further wrote that PCK, in terms of the most regularly taught topics in one's area, includes:

- » The most useful forms of representations of those ideas, the most powerful analogies, illustrations, examples, explanations, and demonstrations---in a word, the ways of representing and formulating the subject that makes it comprehensible to others. Pedagogical content knowledge also includes an understanding of what makes the learning of specific topics easy or difficult: the conceptions and preconceptions that students of different ages and backgrounds bring with them to the learning of those most frequently taught topics and lessons (Shulman, 1987, p. 8).

In 2013, Mavhunga and Rollnick argued that PCK is topic-specific, developing the Topic Specific Pedagogical Content Knowledge (TSPCK) framework. The TSPCK framework describes knowledge that teachers can use to transform content into a form understandable to learners (Mavhunga & Rollnick, 2013). With its five components—curricular saliency, learner prior knowledge (including misconceptions), what is difficult to teach, representations (including analogies) and conceptual teaching strategies—TSPCK provides ways for content to be successfully transformed for teaching during planning and instruction.

Learner prior knowledge describes the preconceptions that learners bring with them to a learning environment. Curricular saliency is a teacher's ability to identify the big ideas of a topic and its subordinates, sequence them, and grasp their importance. What is difficult to teach refers to whatever makes the learning of specific topics difficult. Representations including analogies refers to illustrations, examples, explanations and demonstrations. Conceptual teaching strategies refers to the knowledge of teaching strategies most likely to be effective when teaching a specific topic. These five components assist teachers in considering what learners already know about a topic, the big ideas it involves, as well as a consideration of the knowledge that learners should possess in order to understand the topic. Mavhunga and Rollnick (2013) have shown that TSPCK can be used to fast-track the development of PCK in pre-service teachers. As has already been indicated, the Division of Science at the Wits School of

Education has adopted TSPCK as a scaffolding framework to guide their teaching of methodology courses.

In Tübingen, two aspects—the abstraction cone of learning (Lalley & Miller, 2017) and the biologically relevant working methods (Gropengießer et al., 2016, 2018)—are an important part of the lecture “Fachdidaktik”. Parallel to the WSoE, the cone of learning is concerned with representations in the widest sense (including original objects), and can be integrated into the TSPCK as part of “Representations”. Similarly, the biologically relevant teaching methods overlap in their basic idea with the “conceptual teaching strategies”. Thus, the two schools have overlapping basic teaching content. With regard to the TüSE, Gropengießer et al. (2018) is a general textbook on biology education written in German and in use since the 1980s. This means that many cohorts of prospective teachers have read the book and been instructed along the lines of the publication. There are other books concerned with biology teaching, but this is the most widespread book and has the most editions, being updated every five years. Another benefit is that the textbook is written by German experts, therefore many authors contribute to the book, and every chapter is usually written by one or two renowned German biology teacher educators. This distinguishes the textbook from all others that have been written by a small team of two or three authors. The book is additionally used in both phases of teacher education, in the university phase and in secondary teacher education at schools. In this chapter, we have drawn on two important aspects from the contents of the book: the cone of learning and the biologically relevant teaching methods. Figure 1 below shows the cone of learning (adapted from Gropengießer et al., 2018, based on Lalley & Miller, 2007, though with a different methodology).

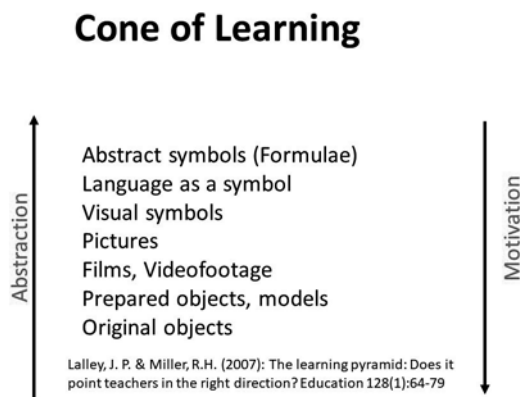

*Figure 1 Cone of learning*

The cone of learning is about the representations that can be used in biology teaching and learning. This overview arranges modes of representations according to their motivational effect on learners and visualizes the relationship between motivation and abstraction. These representations can be grouped along two continua. The first continuum is related to the abstraction level of the representation. Based on education studies, the argument is that less abstract representations foster learning success and motivation (see Chatterjee et al., 2015; Hummel & Randler, 2012; Novak & Schwan, 2021). For example, Hummel and Randler (2012) and Wilde, Hußmann, Lorenzen, Meyer and Randler (2012) showed that teaching about mice is more motivating and generates higher learning success when living animals are used instead of videos. Of course, there are numerous exceptions to this rule. For example, human biology cannot be taught with original objects and requires non-human animal organs or 3D models as media.

Following this continuum, there is an increasing abstraction from originals, which have the lowest or no abstraction level, followed by modified or prepared originals and objects that are three-dimensional representations, such as models (e.g., of organs like the heart). On the next level, two-dimensional representations follow, beginning with video footage. This is because they are two-dimensional but contain some kind of temporal structure, such as processes, so it is possible to follow a process, like the beating of the heart, on video. On the next abstraction level are pictures that are two-dimensional but lack the process component. Thus, using only an image of the heart while the function is described with a text is less motivating and more abstract. Furthermore, symbols like pictograms follow, as they are two-dimensional but do not show the original pictures and have reduced information content. In this case, one could use simplified images of hearts, which show only the four parts (the atria and ventricles) without any details. Amongst the most abstract representation are language, and symbols such as structural formulae or chemical formulae.

The cone of learning shows that when abstraction levels increase, the motivation of students decreases. To illustrate this, I will use the following example. When teaching the structure and internal organs of vertebrate fish, the original object would be the best choice, from Gropengießer et al.'s theoretical background. Therefore, using a real fish obtained from a butcher for teaching has the lowest level of abstraction; it is real and original, so it is considered to be the most motivating object. On the next abstraction level, the model of a fish would be the second choice, followed by a video showing the dissection and the organs, then by images only, and then by written text. In this respect, biology teaching should always search for the least abstract and most motivating representations. However, this does not only have to do with motivational

aspects, as higher motivation relates to higher cognitive gain (Randler, 2009). Nevertheless, the focus is mainly on motivation. In this study, an effective lesson was viewed as one in which the representations were least abstract. This is taught as one of the basics in the lecture “Fachdidaktik”, which informs teaching students' decisions in lesson planning.

### 3 Relating the cone of learning (Tübingen) to the TSPCK framework (Wits)

Comparing the concept of the cone of learning to the TSPCK framework used at the WSoE, some links as well as some disconnections become apparent. One link is that the cone of learning's focus is on representations, which is one aspect or component of the TSPCK framework that a teaching student must consider when planning. However, with the cone of learning, the focus is on the relationship between abstract and concrete representations, whereas in the TSPCK framework, the initial focus is on the nature of the concept to be taught and the teaching students' intentions. Therefore, in WSoE Biology Education classes, questions called prompts (Loughran, Mulhall & Berry, 2004) are used to guide the teaching students to understand the nature of the concept to be taught, so that they can then use that understanding to choose appropriate representations. Examples of such prompts are:

1. What do you intend learners to learn about this idea?
2. Why is it important for learners to know this?
3. Difficulties/limitations connected with teaching this idea.
4. Knowledge about learners' thinking which influences your teaching of this idea.

The fourth point is also taught in Tübingen, but usually in the education classes, and is related to Klafki's questions for didactical analyses. Klafki developed seven basic questions with some additional subquestions. Four of these didactical questions are summarized here: 1) which larger topic does this topic represent; 2) how can children and young people relate to this topic; 3) what is the topic's importance for the future; and 4) what is the inherent structure of the topic (Klafki, 1980)? Below, an example that was used in the previous paragraph and the first three prompts were used to illustrate how the prompts help the teaching student sharpen the focus of the lesson and determine appropriate representations. Referring to the first prompt, if the intention is for learners to learn the concept of fishes' internal organs, then the dissected fish is the most appropriate representation. However, if the intention is to teach



about the fish's habitat and behavior, a real fish will not be the most appropriate choice of representation. After this, looking at prompt three—difficulties associated with teaching a particular concept—when teaching about the heart, one of the difficulties is that learners find it difficult to see heart valves and sometimes also atria in a real heart that has been dissected. In such a case, a model may be a better representation for helping learners understand the heart's structure. Therefore, while a real heart could, according to the cone of the learning, be the most motivating representation, it may not be the best choice for a teaching student who is using the TSPCK framework and the associated prompts.

### 3.1 Biologically relevant teaching methods

The other concept used in the lecture “Fachdidaktik” is that of biologically relevant teaching methods. It focuses on the competencies that biology teachers need to help learners develop. Table 1 below (adapted from Gropengießer et al., 2018) summarizes these competencies.

Competence	Example
Fostering competencies, e.g., process-related competencies	Using a microscope, dissections, observations
Experimental competencies (sometimes also labelled “scientific reasoning” or “scientific inquiry”)	Planning experiments, explicating hypotheses, collecting data
Model competencies, use of models	Evaluate existing models, improve or develop own models
Gaining knowledge of biological processes	Observing, comparing, experimenting, using models, applying working techniques, microscoping
Working with living organisms	Observe in nature, make non-invasive experiments

*Table 1 An overview of the competencies that the biologically relevant teaching methods must develop in learners*

The biologically relevant methods are not based on a hierarchy, because all the methods depicted in Table 1 are biologically relevant methods, some of them explicitly mentioned in the governmental curricula. These methods include competencies involved in scientific (biological) processes, such as carrying out experiments and using models. These aspects are usually considered to be on a higher level of the cognitive hierarchy than more practical working methods (KMK BW, 2016). However, these are also important concerns: observing animals/plants, comparing different

materials, and applying working techniques such as microscoping. Using living organisms for teaching is also an important method, which overlaps with the cone of learning, where originals are the most motivating and least abstract representation. With regard to these teaching methods, students should include biologically relevant teaching methods in their lesson plans and carry them out in a practical manner. Using the fish example above, this would mean that students themselves should dissect a fish to learn the internal structure. In this case, dissection is a relevant biological method (Randler et al., 2012). Similarly, doing experiments on their own is rated higher than merely seeing a picture of an experiment and reading about the method (Randler & Hulde, 2007). Looking through a microscope is more practical and rated higher than just looking at microscopic images. Because of this, students have to explain in their lesson plans why they have chosen a specific method over another, or why they do not use any specific method. For example, when teaching about climate change, practical work is sometimes impossible, and when teaching evolution, students cannot observe millions of years of evolution during their lessons. In this case, they would have to argue for the method they think is most adequate, e.g., a simulation game for the topic of evolution. In this study, an effective lesson plan was considered to be one with methods that would actively involve learners in the teaching and learning process by using less abstract representations.

### 3.2 Relating the 'biologically relevant teaching methods' (Tübingen) to the TSPCK framework (Wits)

When the concept of biologically relevant methods is compared with the TSPCK framework, similarities with the component *conceptual teaching strategies* become apparent. The description of biologically relevant methods shows that if applied appropriately, methods that engage students and develop expected competencies can be selected. While the TüSE approach expects students to provide reasons for the choice of methods chosen in the lesson plans, it does not provide scaffolds or reasoning tools to support the development of that reasoning. At the WSoE, it was this shortfall in the methods that motivated the adoption of the TSPCK framework. The component *conceptual teaching strategies* in the framework scaffolds the students' thinking and reasoning by prompting them to consider the other four components, i.e., *learner prior knowledge including misconceptions, curricular saliency, difficulties associated with the teaching and learning of the concept* and *representations*, in deciding the strategies for teaching a particular concept. Considering these four components encourages teaching methods to be chosen that are relevant for the teaching of a particular concept to a particular group of students.

### 3.3 Research design

At the WSoE in general, but more specifically in the teaching of biology methods courses, the teaching of methods courses to pre-service teachers (referred to in this study as teaching students) training to be biology teachers is informed by the Topic Specific Pedagogical Content Knowledge Framework (Mavhunga & Rollnick, 2013) in order to support teaching students' ability to plan effective lesson plans. In Tübingen, there is no specific framework that guides the teaching of teaching methods. As indicated earlier, teaching students learn to teach based mainly on two key concepts: the cone of learning (Lalley & Miller, 2017) and the biologically relevant teaching methods (Gropengießer et al., 2016, 2018). The scaffolding component is achieved by giving general explanations for lesson planning in the introductory lecture “Fachdidaktik”, a mandatory lecture (see next section for details) that is presented throughout the semester. The scaffolding component combines theoretical approaches with empirical support from evidence-based research, then providing best practice examples of biology lessons.

## 4 Description of the Tübingen introductory lecture “Teaching Biology (Fachdidaktik)”

Fachdidaktik is a mandatory general lecture about teaching biology. The German Fachdidaktik approach has a strong theoretical basis. In Fachdidaktik classes, teaching methods and methodologies are discussed and developed, based on theoretical and empirical research. The basic Fachdidaktik lecture is therefore theory-based in its content, but also includes empirical studies about biology teaching and, lastly, best practice examples that demonstrate the combination of all three aspects. In this lecture, the basic principles are laid out. The theory part of the lecture comprises some kind of axiom, e.g., the way that biology, because of the definition of “bios” (life), should be considered with living objects. From an evidence-based or research-based viewpoint, studies are presented that examine the aspect of living organisms in teaching, their influence on (cognitive) learning success, on motivation, and on emotions such as interest in biology. Furthermore, best practice examples of lessons dealing with living organisms are presented. The main focus is to clearly show how theory informs teaching. Empirical studies are needed to test the theoretical perspective and how it can be taught in an everyday classroom. During the following course of studies, students enroll in a second course (biology lessons planning), where the main aim is to develop

a teaching sequence, usually for about 90 minutes. This teaching sequence should be informed by the knowledge gained in the previous lecture. The students have to develop a lesson plan based on the key findings of the lecture “Fachdidaktik”. The students not only present the lesson plan, but also incorporate some microteachings, where they make use of the other students as school students. They deliver their lesson plans in part as “real” lessons. This is an important topic, as students often claim that biology is a rather disparate subject without connections to other subjects, such as genetics, botany, evolution, microbiology and molecular biology. Therefore, a curriculum was developed where one step is related to the next. Although we have never tested it, we assume a higher motivation and cognitive learning success when these two parts are interrelated.

### 5 Lesson plan sampling

During the winter term 2019/2020, sixteen TüSE lesson plans were collected, in which the topics were based on the curriculum of the federal state of Baden-Württemberg (MKS). The specific topics covered in the lesson plans were ecology, evolution, and biodiversity. Two parallel courses taught by two different university teachers were studied. The students had to plan real lessons that should be teachable at regular schools and have a length of 90 minutes. They were advised to follow the instructions given in the lecture “Fachdidaktik”, which they had to finish prior to the lesson plan course. They were told that they should i) reason about the representations (abstraction, motivation), and ii) consider including real biological working methods in their lesson plans. The lesson plans contain a section dedicated to representations, in which the students write down the representations they would use for each topic. Another column contained the activity of the students, like reading, discussing, or carrying out an experiment.

### 6 Lesson plan analysis

Qualitative documentary analysis was applied (mainly based on Mayring, 2019) with respect to the aspects mentioned in the cone of learning (Figure 1) and the biologically relevant working methods and competencies. Aspects of the cone of learning and the biologically relevant methods could be extracted directly from the lesson plans, as these plans contain the respective columns. For example, students write “pu-

pils watching a video”, so the representation video is extracted. Concerning the biologically relevant teaching methods, students write, for example, “pupils doing experiments themselves”, so this was also easy to extract from the lesson plans.

The detailed analysis therefore involved identifying the representations that were planned for. The choice of representations was then compared with a possible “gold standard”. This gold standard refers to the choice of the optimal representation, meaning a representation that is likely, according to the cone of learning, to promote higher learner motivation. For example, if introduction to ecosystems was taught, the gold standard would be the use of the real ecosystem. If it is not used, the next level would be the models, followed by the videos. Because of this, the students' choice of representation was checked with reference to the cone of learning. The questions that guided the analysis included: what is the concept that was planned for? What is the ideal teaching method for this concept in terms of learner motivation for the particular concepts chosen by the students? What was possible in the same situation in the same place? If it were possible to leave the classroom within a few minutes and enter an ecosystem, then this would be labelled the gold standard that the student should have chosen under the circumstances.

Similarly, the biologically relevant teaching and learning methods have been compared to the ones that were possible, also at the same date and location. For example, when a textbook included an experiment that could have been carried out by the students themselves, it was also seen as non-optimal teaching. A classification into low, medium and high was used to represent the extent of the manifestation of both the representation's abstraction and the biologically relevant teaching methods. With regard to abstraction, a low level was rated best (e.g., an original object, like the fish), and a high level of abstraction was rated worst. As for the teaching methods, good teaching methods (e.g., use of dissection, experiment, and observation) were rated as high, while teaching methods considered poor (e.g., reading a textbook and making notes) were rated as low.

## 7 Results

Table 2 shows the analysis results of the sixteen lesson plans that were developed for the teaching of ecology and evolution. As described in the previous section, the abstractness of the representations that were chosen by the students was classified as high, medium or low, with low abstraction levels being rated as more motivating. Biologically relevant teaching methods were rated as high, medium or low, with high

meaning greater relevance. Alternative representations are examples of more appropriate representations that could have been used under the circumstances, while alternative methods are concerned with better teaching methods.

Table 2 shows that thirty-two representations were identified across the sixteen lesson plans. Below, we discuss the representations' levels of abstraction and the relevance of teaching methods that were chosen by teaching students, as revealed in the lesson plans.

Student	Topic	Identified representation in students' lesson plans	Classification of representation's abstraction	Classification of teaching methods' relevance	Possible alternative representation	Alternative method for biologically relevant methods/work
1	Biotope & ecosystems	Film clip about different ecosystems	Medium	Medium	Real ecosystem outside	Make real environmental measurements
		Paperwork about different ecosystem	High	Low		
		Planting a "bottle garden"	Low	High		
2	Ecosystems	Picture, paperwork, text	High	Low	Real ecosystem outside	Make real environmental measurements
3	Bergmann's rule	Pictures	Medium	Low		No alternative needed
		Experiments with water of different temperatures and volumes	Low	High		
4	Bergmann's rule	Cooking differently sized potatoes, using thermometers	Low	High		No alternative needed
5	Food chain & food web	Pictures of species	Medium	Medium	Original objects, three animal examples	
		Food chains with text	High	Low		
		Simulation (computer)	Medium	High		

6	Food chain & food web	Pictures	Medium	Medium	Original objects, three animal examples	
		Real food chain (pictures and using a string)	Low	Medium		
7	Biotic factors	Pictures of animals	Medium	Medium	Real ecosystems	Real measurements
		Paperwork	High	Low		
		Game / play-like activity	Low	Medium		
8	Abiotic factors	Compare different biotopes outside, measure environmental variables	Low	High		
9	Carbon cycle	Fridays for Future	Low	Medium	Video simulation	
		Puzzle / paperwork	Medium	Low		
10	Carbon cycle	Real charcoal	Low	–	No alternative	
		Video	Medium	Medium		
11	Adaptations of Vertebrates	Pictures	Medium	Medium	Comparison of real skeletons	
		Paperwork	High	Low		
12	Adaptations of Vertebrates	Pictures, Paperwork	Medium	Low		
13	Darwin's theory	Simulation of selection	Medium	High		
		Pictures, paperwork	High	Low		
14	Darwin's theory	Pictures	Medium	Medium		
		Play-like activity / Simulation	Medium	High		
15	Evidence for evolution	Paperwork Jigsaw method	High	Low		
16	Predator-prey relationships	Pictures	Medium	Medium	Simulation	
		Paperwork	High	Low		
		Skulls of prey and predator (teeth)	Low	High		
		Graphics / Population dynamics	High	High		

*Table 2 Results of the analysis of the 16 lesson plans from Tübingen in the context of teaching evolution and ecology*

7.1 Chosen representations' levels of abstraction

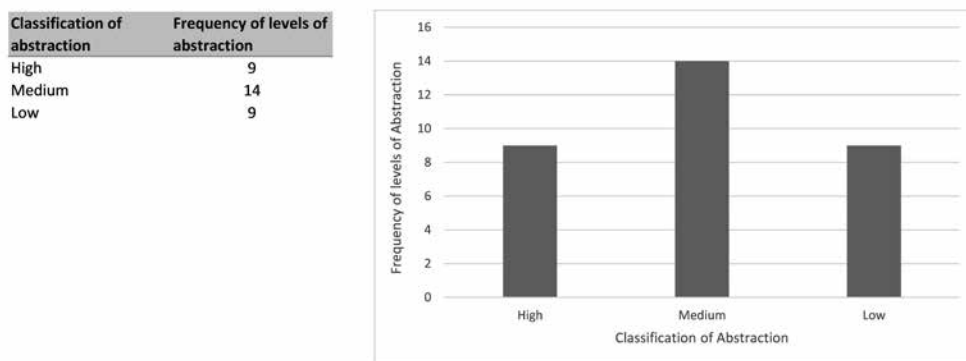

Figure 2 A graphical representation of the representations' abstraction levels, which manifested across all teacher students' lesson plans

All in all, Table 2 shows that nine out of the thirty-two representations were in the form of paperwork. Of these nine representations, six were used in conjunction with pictures and with original representations and graphics. Paperwork and graphics fall under high abstraction, pictures fall under medium abstraction, and real objects fall under low abstraction. In addition to the six pictures that were used with paperwork, pictures were also used in three other lesson plans (in conjunction with text, an experiment and a simulation). Figure 2 is a graphical representation of the abstraction levels, of the representations which were indicated across all teacher students' lesson plans. Because more than one representation was used in some lessons, the total number exceeds N=16.

Figure 2 shows that nine out of the thirty-two representations were at a high abstraction level, fourteen were at a medium level and nine were at a low level. Nine out of the thirty-two teaching methods identified in nine of the sixteen lessons contained highly relevant methods, such as experiments carried out by the students themselves. Eleven methods were at a medium level while eleven were at a low level, such as reading text and extracting it into a working sheet. Figure 3 below shows three classifications concerning the manifestation of biologically relevant working methods. As with the abstraction levels, because in some lessons more than one method was used, the total number exceeds N=16.



## 7.2 Comparison of the chosen representations with the gold standards

As explained earlier, the gold standard refers to the choice of the optimal representation, optimal meaning a representation that is likely to promote higher learner motivation according to the cone of learning. The teaching students' lesson plans were based on two broad biology topics, namely ecology and evolution. These topics are used as sub-headings in this section to highlight the quality of students' chosen representations and teaching methods.

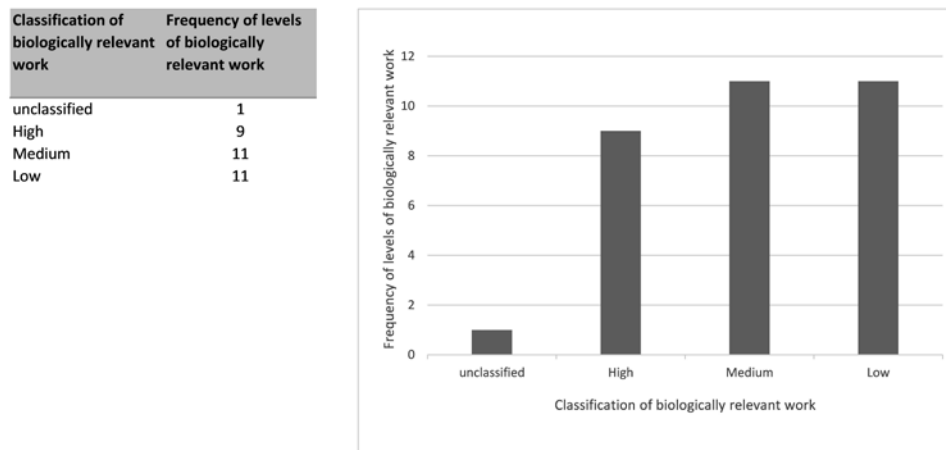

*Figure 3 Classification of the manifestation of biologically relevant working methods in the 16 lesson plans*

### 7.2.1 Topic: ecology

Students 1 to 10 planned to teach topics on ecology. The topics that were planned for are ecosystems, Bergmann's rule, food chains and webs, biotic factors and the carbon cycle. Lesson plans #1 and #2 were on ecosystems. In these two lessons, one student used a video/ film clip which provided medium-level abstraction, but used it in combination with the real objects. This lowered the abstraction level for some aspects of the lesson. Both students used paperwork, which is a plausible alternative in teaching these topics. However, a real ecosystem would be the optimal representation, as the location of the course is near a botanical garden. Getting students to take measurements in a real ecosystem would therefore be a relevant teaching method. When teaching ecosystems, students could just leave the classroom and compare different micro-ecosystems that are reachable on foot within a few minutes.

Lesson plans #3 and #4 were concerned with Bergmann's rule, which is usually illustrated by different penguin species: smaller penguins live near the equator and larger ones near the South Pole (Meiri & Dayan, 2003). Here, one student used pictures to portray the problem of body size versus latitudinal gradient, which is of medium abstraction. However, each student chose a different experimental / observational approach. Both approaches were concerned with larger bodies cooling down at a slower rate than smaller ones. However, one group used potatoes of different sizes, while the other used water beakers of different sizes. Students then had to measure temperature changes over a given period of time. In these two lessons, therefore, the level of abstraction was low and the teaching methods were biologically relevant.

Lesson plans #5 and #6 were on the topic of food chains and food webs. Student 5 used text, pictures of food chains and webs, and a computer simulation as representations, while student 6 used pictures of organisms and asked students to construct food chains using pictures and string. Most of the representations were of medium abstraction and the methods of teaching were biologically relevant. For lesson plan #7, as with lesson plans #1 and #2, the choice of representations was paperwork with books, texts, and pictures about different ecosystems. Students had to compare the biotic and abiotic factors of ecosystems and construct a table at the end of the lesson. This is from the very abstract representation level (teach ecology from paper), and also from the biologically relevant teaching methods. Paperwork is rated the lowest because it is not tied directly to biological methods. This can be directly contrasted with lesson plan #8, where students left the classroom to take some biotic / abiotic measurements in front of the classroom, e.g., by going out and comparing a small fragment of wood versus a meadow, focusing on measures like differences in ambient temperature, hygro, lux and wind speed between the locations. According to the cone of learning, the motivation is high because students encounter a real ecosystem, not a representation, while the other lesson plans used language, symbols and pictures. Furthermore, taking real measurements is a biological method, fitting the requests made by Gropengießer et al. (2018, Table 1). It is therefore rated much higher in terms of both abstraction of representation and biologically relevant teaching methods. These examples show that such teaching is possible and can be implemented into everyday lessons. In lesson plans #9 and #10, which were on the carbon cycle, representations at a low and medium level of abstraction were chosen by the teaching students.

### 7.2.2 Topic: evolution

Lesson plans #11 to #16 were based on different aspects of evolution, namely animal adaptations, Darwin, evidence for evolution and predator-prey relationships. Since the topic of evolution is abstract by nature, most of the representations used were of high and medium abstraction. However, for some of the aspects, there were alternative representations that teaching students could use. For example, with lesson plans #11 and #12, which dealt with adaptations of vertebrate species, different classes of vertebrates (e.g., fish, amphibians, reptiles, birds, and mammals) were compared by using different pictures, e.g., of their skeletons. However, a better alternative to the cone of learning would have been to use real skeletons and stuffed animals or models for the comparison, e.g., of the limbs. This would have been less abstract and more motivating. Also, comparing is an essential biological research method that can, of course, also be done with pictures on working sheets. However, motivationally speaking, it might be better to use models or real objects.

## 7.3 Discussion

The purpose of this study was to investigate the cone of learning and the biologically relevant methods as scaffolding tools for developing teaching students' capacity to prepare effective lesson plans. The questions that guided this study were:

1. How do the concepts of the cone of learning and biologically relevant methods used at Tübingen Biology Education Department support the scaffolding of lesson planning?
2. How do the concepts of the cone of learning and biologically relevant methods used in Tübingen relate to the TSPCK framework that is used at WSoE?

The results of this study showed that a representation was used in each of the sixteen Tübingen students' lesson plans to facilitate learning. However, pictures and paperwork, which fall under medium abstraction, were the most used representations, despite the availability of more motivating and less abstract alternatives. In their lesson plans, teaching students seemed to have ignored or failed to apply the aspects of lesson planning that they were taught in the general lecture about biology teaching. For example, about half of the students ignored one of the main questions that they needed to respond to in their planning: "What did you carry out as a biological method during your lesson?", and secondly: "Did you consider the abstraction level of the

representation by focusing primarily on the most original and least abstract object?” As seen in Table 2, there were plenty of alternative and better representations that students could have used.

### **8 Relating Tübingen students' lesson planning to the lesson planning approach used at WSoE**

The analysis and discussion above shows that Tübingen students' lesson plans included at least one representation and an attempt to engage students in biologically relevant methods. What was missing in the lesson plans was students' reasoning for the choice of the representations and of the biologically relevant methods. Therefore, while the representation may appear to be less abstract, a teaching student's reasoning and intention for the lesson could be aligned with that particular representation and biological method. As mentioned in an earlier viewpoint, aspects such as the intention of the teacher, or the nature of the concept being taught and learner prior knowledge can influence the choice of representation and the biologically relevant method used in a particular lesson. There is therefore a need to devise ways of capturing teaching students' reasoning for the choices they make as reflected in their lesson plans. At the WSoE, the TSPCK-aligned lesson plan templates have prompts that provide teaching students with opportunities to verbalize their thinking and reasoning as they plan. In this way, teacher educators can assess the teaching students' reasoning and the appropriateness of the representations and conceptual teaching strategies that are chosen.

### **9 Limitations of the study**

Only one source of data, teaching students' lesson plans, was used in this study. Being a qualitative study, multiple data sources would have improved the validity of the results. Another data source could be the interviews of the teaching students. In this study, the authors had plans to interview students in order to acquire more insight into their planning from their pedagogical reasoning. However, due to restrictions imposed because of the COVID-19 pandemic, the interviews could not be carried out.

## Literature

- Bishop, K., & Denley, P. (2007). *Learning science teaching: Developing a professional knowledge base*. McGraw-Hill Education.
- Chatterjee, H. J., Hannan, L., & Thomson, L. (2015). An introduction to object-based learning and multisensory engagement. In H. J. Chatterjee & L. Hannan (Eds.), *Engaging the Senses: Object-Based Learning in Higher Education* (pp. 1–18). Routledge.
- Derri, V., Papamitrou, E., Vernadakis, N., Koufou, N., & Zetou, E. (2014). Early professional development of physical education teachers: Effects on lesson planning. *Procedia—Social and Behavioral Sciences*, 152, 778–783.
- Gropengießer, H., Harms, U., & Kattmann, U. (2016). *Fachdidaktik Biologie* [Subject didactics Biology]. Aulis.
- Gropengießer, H., & Marohn, A. (2018). Schülervorstellungen und conceptual change [School student conceptions and conceptual change]. In *Theorien in der naturwissenschaftsdidaktischen Forschung* (pp. 49–67). Springer.
- John, P. D. (2006). Lesson planning and the student teacher: Re-thinking the dominant model. *Journal of Curriculum Studies*, 38(4), 483–498.
- Klafki, W. (1980). Zur Unterrichtsplanung im Sinne kritisch-konstruktiver Didaktik [On lesson planning in the sense of critical-constructive didactics]. In B. Adl-Amini & R. Künzli R. (Eds.), *Didaktische Modelle und Unterrichtsplanung*. Juventa.
- Kosnik, C., & Beck, C. (2009). *Priorities in Teacher Education: The 7 Key Elements of Pre-Service Preparation*. Routledge.
- Lalley, J. P., & Miller, R.H. (2007). The learning pyramid: Does it point teachers in the right direction? *Education*, 128(1), 64–79.
- Loughran, J., Mulhall, P., & Berry, A. (2004). In search of pedagogical content knowledge in science: Developing ways of articulating and documenting professional practice. *Journal of Research in Science Teaching*, 41(4), 370–391. <https://doi.org/10.1002/tea.20007>.
- Mavhunga, E., & Rollnick, M. (2013). Improving PCK of chemical equilibrium in pre-service teachers. *African Journal of Research in Mathematics, Science and Technology Education*, 17(1–2), 113–125.
- Mavhunga, E., & Rollnick, M. (2017). Implementing PCK topic by topic in methodology courses. In A. Sickel, & S. Witzig, *Designing and Teaching the Secondary Science Methods Course* (pp. 149–170). Brill Sense.
- Mayring, P. (2019). Qualitative content analysis: Demarcation, varieties, developments. *Forum Qualitative Sozialforschung/Forum: Qualitative Social Research*, 20(3).
- Meiri, S., & Dayan, T. (2003). On the validity of Bergmann's rule. *Journal of Biogeography*, 30(3), 331–351.
- Nesari, A. J., & Heidari, M. (2014). The important role of lesson plan on educational achievement of Iranian EFL teachers' attitudes. *International Journal of Foreign Language Teaching and Research*, 2(5), 27–34.
- Novak, M., & Schwan, S. (2021). Does touching real objects affect learning? *Educational Psychology Review*, 33(2), 637–665.
- Nyamupangedengu, E. (2015). *Teaching Genetics to Pre-Service Teachers: A Teacher Educator's Approach to Transformative Practice Through Self-Study* (Doctoral dissertation). University of the Witwatersrand, Johannesburg.
- Randler, C., & Hulde, M. (2007). Hands-on versus teacher-centred experiments in soil ecology. *Research in Science & Technological Education*, 25(3), 329–338.
- Randler, C. (2009). Association between emotional variables and school achievement. *International Journal of Instruction*, 2(2).
- Randler, C., Wüst-Ackermann, P., Vollmer, C., & Hummel, E. (2012). The relationship between disgust, state-anxiety and motivation during a dissection task. *Learning and Individual Differences*, 22(3), 419–424.
- Rusznayk, L., & Walton, L. (2011). Lesson planning guidelines for student teachers: A scaffold for the development of pedagogical content knowledge. *Education as Change*, 15(2), 271–285. <https://doi.org/10.1080/16823206.2011.619141>
- Shen, J., Poppink, S., Cui, Y., & Fan, G. (2007). Lesson planning: A practice of professional responsibility and development. *Educational Horizons*, 35(4), 248–258.
- Shulman, L. S. (1987). Knowledge and teaching: Foundations of the new reform. *Harvard Educational Review*, 57(1), 1–22.
- Wilde, M., Hußmann, J. S., Lorenzen, S., Meyer, A., & Randler, C. (2012). Lessons with living harvest mice: An empirical study of their effects on intrinsic motivation and knowledge acquisition. *International Journal of Science Education*, 34(18), 2797–2810.

## Chapter 9

# Global Realities and Economic (Teacher) Education in the Twenty-First Century: A Conceptual Contribution

3

Emmanuel Ojo and Taiga Brahm

*This chapter examines how economic teacher education in South Africa and Germany must develop in terms of curriculum and pedagogy in order to address contemporary global challenges in multicultural contexts. The chapter focusses on economic teacher education but draws on economic content knowledge in higher education curricula, considering the two broad fields of microeconomics and macroeconomics, on which the discipline of economics is built. Drawing on the South African and German schooling contexts, the chapter presents an overview of the literature and theoretical constructs. It discusses the curriculum of economic teacher education and the role of the economics teacher. For this we use five contemporary discourses, focusing on money beyond fiat, pluralism in economic thinking, sustainability as thinking beyond economic growth, the intersectionality of migration, culturalization and 'glocalization', and digitalization in the economics classroom. The authors draw on current studies related to economic teacher education, contemporary discourses influencing 21<sup>st</sup> century economic teacher education content and context, and their own practice as teachers and researchers to argue for the importance of and need for reflective practice that is integrative and critical. This is to be achieved through curriculum development and differentiated teaching in South Africa and Germany's multicultural contexts.*

<http://dx.doi.org/10.15496/publikation-76373>



## 1 Economic education and its challenges

The year 2008 challenged the way economics is thought of as a discipline. The global economic downturn happened unexpectedly. Consequently, societies asked why economists could not predict this economic meltdown or mitigate its negative impact. In the same year, Nakamoto (2008) authored a white paper on the use of blockchain technology to create Bitcoin, now known as the world's leading digital currency. The years after this economic crisis saw the world questioning the relevance of economics as a discipline and the role played by leading economists in shaping the discipline, beyond thinking of economic growth as the ultimate goal of society. Both in the global north and the global south, the role of economists in policymaking is key in the development of economies and global society (Hirschman & Berman, 2014). With evidence of the poverty and inequality across the world, the dichotomy between the global north and south, especially in the wake of the crisis and the subsequent years of recovery, was brought to the fore. While the world has evolved since this crisis, the need to rethink the economics curriculum and how it is taught in schools and in universities, has not lost any topicality. Instead, the global pandemic has restated its importance.

The COVID-19 pandemic has strained a global economy that, after the 2008 economic crisis, is already delicate. With the global outlook pointing more to a recessionary trend according to the World Bank (2022), the discipline of economics has come into the limelight once again. These events have cast a completely different light on the years 2020 and 2021 than was anticipated. Fifteen months after the initial global lockdown, the need to engage what we teach in economics (the curriculum), how we teach it in the classroom, specifically in high schools (the pedagogy), and how we make the link with current national and global challenges (contemporary issues), has to be revisited if we take the future of economics education seriously.

The overarching question in this chapter is: how should economics teacher education be designed in terms of curriculum and pedagogy in order to address contemporary global challenges in multicultural contexts, beyond the pandemic, in a future of uncertainties? In answering this question, we examine economic teacher education from a conceptual perspective, drawing on the literature and bringing together different perspectives from the South African and German contexts. Through the lens of this literature and the authors' reflective practice as teachers and researchers in economic education, the chapter argues for an integrative and critical reflective practice in reconceptualizing the economics curriculum and how it is taught in the

classroom. The authors argue for rethinking and re-examining the economics content and how it is taught in a multicultural and diverse classroom. The next section starts with a review of the literature on the theoretical constructs of the economic curriculum and how it is taught in the classroom in both high school and the university contexts.

## 2 Teaching economics in Germany and South Africa

In this section, the authors examine the state of economic teacher education. They show the knowledge gap in the literature and argue for the need to re-examine how high school economics is taught in multicultural contexts, drawing on examples from Germany and South Africa.

### 2.1 The curriculum of economic teacher education

Economics is a social science that often assumes the ability of humans to make rational decisions. It seeks to understand how limited resources can be efficiently and effectively allocated amongst unlimited wants. In both the South African and German contexts of economic education, in high school and at university, two branches of economics taught in the curriculum are microeconomics and macroeconomics (Asarta & Méndez-Carbajo, 2020; Walstad, Rebeck & Butters, 2013; Walstad & Soper, 1988). Based on these two branches, the concepts of scarcity, choice and opportunity costs are foundational to the teaching of economics in pre-university and university contexts. These concepts are also referred to as threshold concepts, i.e., they are required for an understanding of economics as a discipline (Bolinger & Brown, 2015). A threshold concept such as opportunity costs “can be considered as akin to a portal, opening up a new and previously inaccessible way of thinking about something. It represents a transformed way of understanding, or interpreting, or viewing something without which the learner cannot progress” (Meyer & Land, 2003, p. 1). Such concepts are also central to the curriculum taught in high schools.



Weighting of curriculum	Topic
Macroeconomics (Weighting 25%)	Economics: basic concepts
	Basic economic problem
	Circular flow
	Quantitative elements
	Economic systems
	Business cycles
Microeconomics (Weighting 25%)	Dynamics of markets
	Public sector intervention and composition of the Republic of South Africa (RSA) economy
Economic pursuits (Weighting 25%)	Economic growth and development
	Money and banking
	Population and labor force
	Labor market
	Redress since 1994
Contemporary economic issues (Weighting 25%)	Unemployment
	Labor relations
	Globalization
	Inflation
	Tourism
	Poverty
	Other economic issues and quantitative elements of economics

*Table 1 The curriculum for the subject of economics in South Africa (Department of Basic education, 2011, p. 8)*

In South Africa, there is a standard curriculum for teaching economics at the High School level, which includes several economics topics, as mentioned above (see Table 1).

In comparison, there is no general curriculum for economics at the High School level in Germany. Economics is taught in various subjects and to different extents in the different federal states. For instance, in Baden-Württemberg, a state in the south-west of Germany, it is obligatory for school students to study economics and vocational orientation from grade 7 or 8 up to the 10<sup>th</sup> grade of high school (depending on the school track). The students who continue schooling until their school leaving certificate (i.e., Abitur) then have the option of choosing economics as a core subject in grades 11 and 12.

In addition to the curricula, the teaching contexts and the level of economic literacy differ. Salemi (2005) argued that students are considered to be economically literate “if they can apply basic economic concepts years later, in situations relevant to their lives and different from those encountered in the classroom” (p. 47). Drawing on the importance of economic literacy in international perspectives, Jappelli (2010) pointed to the large volume of evidence that “economic literacy differs widely across households and tends to be rather limited in the less educated, poorer demographic groups” (pp. F429–F430). In presenting the state of economic teaching in Germany, “economic content is currently not very well anchored in the curriculum” (Happ, Kato & Rüter, 2021, p. 49). In both South Africa and Germany, evidence from the literature showed that the student's previous economic knowledge has an effect on academic success (Fourie & Krugell, 2015; Happ et al., 2021). Economic literacy is depicted as a life skill, highlighting the need for teaching economics in schools and beyond. The teaching of the economics curriculum is very different to other social science subjects. Every economics teacher must have a good command of mathematics to teach the curriculum. Economics and mathematics go together, especially because mathematical operations are a significant tool in teaching and learning the subject. Economic models always present relationships and are often based on data which are represented as (presented in) graphs or diagrams (Ring & Brahm, 2020). To teach these, the teacher must be able to mathematically express the relationships between the dependent and independent variables. In addition to this, graphs are needed to illustrate these relationships for the learners to make connections between theory and reality (Ojo, 2016; Ojo, Booth & Woollacott, 2019; Ojo & Jeannin, 2016). Both in South Africa and Germany, the economics curriculum has been primarily taught through ‘talk and chalk’ (Becker, 1983a, 1983b, 2002; Siegfried & Fels, 1979). This has changed little in the 21<sup>st</sup> century (Becker & Watts, 2001; Onger, 2017). The authors acknowledge that the economics curriculum has been predominantly driven by a neoclassical perspective. While the authors take into account the dominant mode of teaching the economics curriculum and its mainstream neoclassical perspective, the need for curricular transformation and differentiated teaching through critical reflective practice is more relevant today than ever. The 2008 economic crisis sparked a debate over the discipline of economics and challenged the role of economists in society. As the 2020 global pandemic has exacerbated the decade's economic problems, other perspectives should be considered (Dequech, 2007), including plural economics (Davis, 2006). We will address these new(er) developments for economic education further (see section 3.2), but before this, the authors will address the role of the economics teacher and its importance.

## 2.2 The role of the economics teacher

Different conceptions emphasize the importance of the economics teachers' professional knowledge for successful student learning (Rassuli & Manzer, 2005; Sahlberg, 2010). In this context, Shulman (1986) developed a model which includes teachers' content knowledge (CK), a thorough understanding of economic theory, models, and methods; pedagogical content knowledge (PCK), knowledge of how to teach the economic content; and pedagogical knowledge (PK), knowledge about classroom management, student-teacher-interactions, and student learning in general. This model has been further developed in light of the digitalization of teaching and learning by Koehler, Mishra, and Cain (2013), who added the technology component in their so-called Technological Pedagogical and Content Knowledge (TPACK) model. We will focus on the CK and the PCK needed by economics teachers in this chapter (Koehler et al., 2013).

Although highly relevant, this emphasis on individual teachers' knowledge and competences falls short of recognizing the ongoing challenges in economic teacher education. Teachers should, of course, be professionals with regards to how they teach economics. Economics teachers should also develop competencies to reflect upon and shape the future curriculum of economic education (at schools and beyond). The notion of teachers as curriculum developers rather than as implementers of a given curriculum is also aligned with further developing teachers' professional autonomy (Lynch, McCormack & Hennessy, 2017). It also contributes to keeping up professional standards (ibid.): by contributing to curriculum development processes, teachers also further develop their own competencies (Shawer, 2010). Lynch et al. (2017) argued that “teacher engagement in curriculum development can therefore be seen as fundamental to *inter alia*, the profession assuming collective responsibility for the development and maintenance of professional standards, the continued enhancement of a professional knowledge base, and the progression of student-centered learning” (2017, p. 446).

In the following section, we present and discuss major challenges in curriculum development facing economic teacher education globally, and specifically in Germany and South Africa.

### 3 Examining contemporary discourses in economic teacher education in the twenty-first century

This section discusses five contemporary discourses that, according to the authors, are influencing the content and context of economic teacher education in the 21<sup>st</sup> century, as well as how economics is taught. The authors argue that these five discourses were triggered by two events within the two decades of the 21<sup>st</sup> century: the 2008 global economic crisis and the 2020/21 coronavirus pandemic. The authors present these discourses as important conceptual ideas in re-examining and re-presenting the curriculum for economic teacher education and how it is taught.

#### 3.1 Money beyond fiat: The emergence of digital currencies

Social interaction is crucial to production, consumption, and trade. Trade is about exchange and in this process money plays an important role. Money represents value and is the lifeblood of any economy. The varied forms of the lockdowns across the world has impacted global trade and slowed down global capital flows (OECD, 2020). At about the same time as the 2008 economic woes, Nakamoto's (2008) White Paper titled 'Bitcoin: A peer-to-peer electronic cash system' reshaped the world's understanding of money. The author argued for the use of Blockchain and Distributed Ledger Technology (DLT) to redefine money as value beyond fiat with the emergence and growth of digital currencies (cryptocurrencies). The cumulative market capitalization of cryptocurrencies was USD\$237.1 billion in 2019 (Statistica, 2020). Economics as a discipline cannot continue to ignore how such technology has redefined money as value. For example, Peneder (2022) argues that Bitcoin has redefined money as an example of a cryptocurrency. In his words, Bitcoin "constitutes a radical departure from the conventional institution of money, [a system] absent of any central organisation and exclusively based on rules such as those algorithms that define the maximum number of new coins to be issued per period and establish the first transaction in a new block" (p.188). Key stakeholders in the global banking system have claimed that central banks have to take digital currencies seriously (Bossone & Natarajan, 2020; Joshi & Joshi, 2020). The authors claim that Central Bank Digital Currency (CBDC) can disrupt the global financial system, yet with multiple benefits as "efficient trade, greater financial access for millions of people and a reduction in crime" (Joshi & Joshi, 2020, p. 1).

The adoption of digital currencies has heightened during the COVID-19 pandemic, with evidence showing that Mauritius, an African nation, is making bold plans for the

total adoption of digital currencies (De, 2020). The authors argue in this first contemporary discourse that economics as a discipline, and thus economic education, must adapt to the 21<sup>st</sup> century's current realities. As the 2008 economic downturn was happening and challenging the economics discipline (the curriculum, how it is taught and its relevance in the 21<sup>st</sup> century), blockchain technology was redefining money as a store of value, global trade and global financial flows. The discipline has to be aware of this development, as it challenges the way teachers have taught fiat money as a store of value in the economics curriculum. There is compelling evidence that Blockchain and Distributed Ledger Technology (DLT) was adopted during the COVID-19 pandemic in the global economy (Marbough et al., 2020; Peng, 2020). Economics as a discipline must take this disruption seriously. It will affect the development of economic teacher education in multicultural contexts, as well as how teachers teach learners in an uncertain future in which technology plays a significant role in changing global communities. It is important for economics teachers to have content knowledge regarding technology-based kinds of money. At the same time, it is important for them to be able to critically reflect on the challenges of the blockchain technology.

### 3.2 Pluralism in economic thinking

Beyond neoclassical economics, the authors argue for the inclusion of heterodox economic theories in the curriculum and in resource materials for teaching economics in high schools and at universities. This is a key element of the 'multiplicities of meanings' in revisiting economic (teacher) education. To define the subject matter of future economics teaching more precisely, the authors consider economics to be a social science characterized by a plurality of paradigms, explanatory approaches, and methods. In terms of future curriculum development, economics should still be regarded as the core discipline for the training of economics teachers. In addition to the neoclassical economic approach, which is referred to as "mainstream", other approaches—often referred to as heterodox in the Anglo-American discussion (Dow, 2008)—should also be discussed in curriculum development processes in order to include the entire spectrum of plurality in the economic reference discipline. After all, future economics teachers should be able to initiate educational processes among their students that allow them to analyze pressing social challenges and to generate ideas for solutions.

It is well-known that neoclassicism, with its equilibrium model, is considered the chief model of thought, which also predominates in economics textbooks at universities [cf. for a comprehensive analysis of German curricula, see van Treeck and Urban (2016)].

This approach is criticized in particular for its strict assumptions, such as the rational, benefit-maximizing behavior of the human being, the time-constant preferences, the dominance of seeing the economic system in equilibrium, the lack of consideration of information deficits (Hodgson, 2004). Within the neoclassically-oriented mainstream, an increasing plurality can be observed, for example, in behavioral or social science approaches. It is particularly noticeable that the academic discourse shows a growing plurality of theoretical references and methodological implementations, but that this development is taken into account little or not at all, especially in the basic (introductory) courses on economics (Denis, 2009). On the contrary, it appears that the education of economics students (and this includes future economics teachers), at least in the first semesters, involves a relatively clear canon of micro- and macroeconomic approaches (ibid.). As a result, the so-called heterodox schools of thought are often given little attention in the training of economics teachers.

### 3.3 Thinking beyond economic growth: sustainability and the SDGs

The authors contend that economic growth alone cannot adequately describe human prosperity, even though this has historically been the primary indicator of economic progress throughout the world. Beyond economic growth, the concept of sustainability is deemed critical for the discipline of economics and its curriculum. According to the United Nations' World Commission on Environment and Development (*WCED, or the Brundtland Commission*), sustainability development is 'development that meets the needs of the present without compromising the ability of future generations to meet their own needs' (World Commission on Environment and Development (WCED), 1987, p. 24). This notion encompasses economic and social progress, recognizing the efficient use of natural resources, social justice, and the effective protection of the environment (Jucker, 2002). In the light of the north-south divide, the notions of equality and environmental protection are both of particular importance for the further development of economic education. Because of this, there is a need to incorporate sustainability into the economics curriculum and its teaching to make the discipline relevant (Venkatesan, 2021).

### 3.4 Migration, culturalization and 'glocalization'

The authors acknowledge the impact of migration on global economics. With restrictions on movement during the global lockdown, what impact does this have on the curriculum and how it is taught? In extending the pluralism argument, it is im-

portant to think of culture as an element of economic education (Jeannin & Ojo, 2021). The authors also highlight the importance of understanding diversity in multicultural teaching contexts as it relates to the teaching of the economics curriculum. Finally, there is a need to be 'locally relevant and responsible, yet globally responsive' with respect to the economics curriculum and how it is taught. In other words, it is important to be culturally relevant locally within the broader perspective of globalization. Culture shapes societies and invariably shapes the economy.

### 3.5 Digitalizing the economic classroom: what and how?

The COVID-19 pandemic presented an unprecedented situation for schooling worldwide. As of June 2020, UNESCO data claimed that in 144 countries, over one billion students studied at home instead of their usual classrooms in schools, training institutions and universities due to the global lockdown (UNESCO, 2020). Schooling, learning, and teaching have moved online with more use of Learning Management Systems (LMS). Although this chapter does not analyze how economic teacher education responds to this, the authors identify the pandemic as a significant disruptor, highlighting the importance of digitalizing the economics classroom.

Digitalization was a topic in economic education even before the global pandemic. Through the use of digitally supported simulations, learners were supported to further understand economic content and develop important skills (Engelhardt, Johnson & Meder, 2020). In general, digital media can have a positive effect on learners' performance, although this depends on the design and integration in the classroom (Herzig, 2014). This integration is again connected to the teachers' knowledge and skills (Köhler et al., 2008). Above all, it is important to make use of digital media's advantages, such as multimedia, interactivity and adaptivity (Ferrarini, 2017). As graphs and diagrams are crucial material for teaching economics (Ring & Brahm, 2020), digital versions of such representations can further enhance students' comprehension. Digital media can further enable students and teachers to produce diagrams and graphs. Here, the interactive component of a digital diagram comes into play (e.g., changing diagram types, more information to be accessed via hyperlinks).

#### 4 The findings

Drawing on the literature, the reflective practice of the authors as economics teachers and researchers, and the contemporary discourses presented in the previous section, what ‘multiplicities of meanings’ can be deduced from this data as a conceptual frame? In this section, the authors seek to re-engage with what is taught in high school economics and how teachers should be educated to adequately teach it.

Based on the literature, five contemporary discourses were discussed as a basis for reflection for the future of economic education. The disruptions caused by the two global events within the past twenty years are significant. The first was the economic and financial crisis; and the current one, the COVID-19 pandemic, had a snowballing effect on the global economy. With the advent of technology, redefining how we think and trade money as value, two key meanings emerged: the first discusses the foundations for curriculum change and reforms, and the second addresses the pedagogy of the reformed curriculum. For the latter, the authors posit the importance of differentiated teaching. As Happ et al. (2021) noted: “teaching demands that teachers provide a standard of teaching that is appropriate to the [learners] and that picks up the students at their respective levels of knowledge” (p. 49).

The concept of economic growth as defined by growth in the gross domestic product (GDP) of a country is not sufficiently linked to the Sustainable Development Goals (SDGs). For economic growth to be inclusive and sustained, the way the economics discipline defines it and the way economics is taught in the curriculum both need a total overhaul. This will require engaging the foundations of the economic curriculum and rethinking economic theories and models (and the assumptions underlying them) as academic economists in higher education teaching and research (Brahm & Jenert, 2019). Furthermore, the way this reformed curriculum is taught, which is the second meaning of the authors' conceptualization in this chapter, will have to change, taking into consideration that economics is best taught and learned when the concepts are linked to the real world (Ojo et al., 2019).

In sum, critical reflection and discussion need to be implemented in the pedagogy of economic education. To support students in their reflection processes, in-depth reflection must form an integral part of the economics curriculum. Its importance should be emphasized by teacher educators, so that students dare to adopt different perspectives and ask critical questions (Hibbert, 2013). Thus, it is necessary to implement clear tasks and to support students in tackling them, since it is often unclear what teachers expect from their students in critical reflection (Dyment & O'Connell, 2011).



Finally, technology has had a significant impact on the global economy since 2008, including the current Central Bank Digital Currency (CBDC), which is disrupting the global financial system. The economics discipline must acknowledge that new thinking and a reformed curriculum are required for high school economic (teacher) education. This foregrounds economic literacy in high school, for university contexts and for life. In a similar vein, digitalization affected economic teaching even before the major school closings due to the pandemic. Accordingly, both the content and the pedagogy of economic education must be reconsidered to include the massive technological developments the world is currently witnessing.

## 5 Conclusion

Taking the ongoing societal challenges into account, economic teacher education is facing the need for curriculum change and differentiated teaching. Change is needed in at least two ways.

With regard to economic education, it is, first of all, necessary to design the curriculum in such a way that plural perspectives on the global economy and the UN's sustainable development imperatives are considered (see above). This includes the consideration and inclusion of resource materials that could be used in teaching this, and could be achieved by rethinking the threshold concepts earlier identified within the global economic realities of the 21<sup>st</sup> century. The authors argue for a curriculum reform that moves beyond and extends the economic theories and models put together in the previous century. Additionally, a specific course focusing on the current realities could be developed. A more effective way might be to discuss these questions with colleagues in higher education to make more teacher educators aware that the pluralistic approach is necessary from the perspective of economic education. Pluralistically oriented materials are available, for instance the "Economics Anti-Textbook" (Hill & Myatt, 2010).

However, such processes of change in the curriculum and the pedagogy are often connected with feelings of loss and discomfort among teachers (Handal & Herrington, 2003) and students. Research from other school subjects, such as Mathematics, has shown that a curriculum change process will not result in actual changes unless teachers' values and beliefs are considered (ibid.). In a similar vein, it is often stressed that for change to occur, those who are responsible for bringing about new initiatives, i.e., future economics teachers, should be involved in the development and implementation of the required changes. Consequently, economics teachers are seen as

important agents of change, who, in collaboration with the authorities and teacher educators, are co-constructing curriculum change (Fullan, 1993; Hargreaves & Goodson, 2006). From the author's point of view, it is important to already include a critical-reflective practice in initial teacher education. This critical-reflective practice is important for at least three reasons. Firstly, it allows in-depth discussions regarding the underlying assumptions in the discipline of economics, deepening the content knowledge of future teachers. Secondly, it addresses students' beliefs and values, which were shown to impact teachers' curriculum decisions and teaching approaches (Olafson & Schraw, 2006). Thirdly, it prepares teachers for their future role as agents of change in curriculum change processes (Fullan, 1993).

### Literature

- Asarta, C. J., & Méndez-Carbajo, D. (2020). Bringing down the walls in business and management Education: A textual analysis of economic education articles. *Journal of Education for Business*, 1–12.
- Becker, W. (1983a). Economic education research: Part I, issues and questions. *Journal of Economic Education*, 14(1), 10–17.
- Becker, W. (1983b). Economic education research: Part III, statistical estimation methods. *Journal of Economic Education*, 14(3), 4–15.
- Becker, W. (2002). Teaching quantitative methods in economics: Alternatives to theorem and proof and chalk and talk. *Economic Analysis and Policy*, 32(2), 159–180.
- Becker, W., & Watts, M. (2001). Teaching economics at the start of the 21<sup>st</sup> century: Still chalk-and-talk. *American Economic Review*, 91(2), 446–451.
- Beveridge, T. S., Fruchter, L. L., Sanmartin, C. V., & Delottinville, C. B. (2014). Evaluating the use of reflective practice in a nonprofessional, undergraduate clinical communication skills course. *Teaching in Higher Education*, 19(1), 58–71.
- Bolinger, A. R., & Brown, K. D. (2015). Entrepreneurial failure as a threshold concept: The effects of student experiences. *Journal of Management Education*, 39(4), 452–475.
- Bossone, B., & Natarajan, H. (2020). *Getting funds to those in need and enabling access to money during COVID-19, part 3: Central bank digital currencies and other instruments*. Center for Economic Policy Research. <https://voxeu.org/article/covid-19-central-bank-digital-currencies-and-other-payments-instruments>.
- Brahm, T. & Jenert, T. (2019). Untangling faculty misinformation from an educational perspective: Rejoinder to “the menace of misinformation: Faculty misstatements in management education and their consequences”. *Journal of Management Education*, 43(4), 446–453.
- Datar, S. M., Garvin, D. A., Cullen, P. G., & Cullen, P. (2010). *Rethinking the MBA: Business education at a crossroads*. Harvard Business Press.
- Davis, J. B. (2006). The turn in economics: neoclassical dominance to mainstream pluralism? *Journal of Institutional Economics*, 2(1), 1–20.
- De, N. (2020). *Mauritius central banker confirms island's digital currency plans*. CoinDesk. <https://www.coindesk.com/mauritius-central-banker-confirms-islands-digital-currency-plans> [16.01.2022].
- Denis, A. (2009). Pluralism in economics education. *International Review of Economics Education*, 8(2), 6–22.
- Department of Basic Education (2011). *Curriculum and assessment policy statement Grades 10–12 Economics*. [https://www.education.gov.za/Portals/0/CD/National%20Curriculum%20Statements%20and%20Vocational/CAPS%20FET%20\\_%20ECONOMICS%20\\_%20GR%2010-12%20\\_%20WEB\\_BD13.pdf?ver=2015-01-27-154011-050](https://www.education.gov.za/Portals/0/CD/National%20Curriculum%20Statements%20and%20Vocational/CAPS%20FET%20_%20ECONOMICS%20_%20GR%2010-12%20_%20WEB_BD13.pdf?ver=2015-01-27-154011-050).
- Dequech, D. (2007). Neoclassical, mainstream, orthodox, and heterodox economics. *Journal of Post Keynesian Economics*, 30(2), 279–302.

- Dow, S. C. (2008). Plurality in orthodox and heterodox economics. *Journal of Philosophical Economics*, 1(2), 73–96.
- Dyment, J. E., & O'Connell, T. S. (2011). Assessing the quality of reflection in student journals: *A review of the research. Teaching in Higher Education*, 16(1), 81–97.
- Engelhardt, B., Johnson, M., & Meder, M. (2020). *Learning in the time of COVID-19*. <https://dx.doi.org/10.2139/ssrn.3670173>.
- Ferrarini, T. H. (2017). Teaching economics within the multimedia landscape. In M. B. Henning (Ed.), *Innovations in economic education: Promising practices for teachers and students* (pp. 122–143).
- Fourie, A., & Krugell, W. (2015). Determining the economic literacy of introductory economic students in South Africa. *International Journal of Education Economics and Development*, 6(1), 86–96.
- Fullan, M. G. (1993). Why teachers must become change agents. *Educational leadership*, 50, 12–12.
- Handal, B., & Herrington, A. (2003). Mathematics teachers' beliefs and curriculum reform. *Mathematics education research journal*, 15(1), 59–69.
- Happ, R., Kato, M., & Rüter, I. (2021). Results from the test of economic literacy in Germany and Japan: A critical discussion on the gender effect. *Citizenship, Social and Economics Education*, 20(1), 48–68.
- Hargreaves, A., & Goodson, I. (2006). Educational change over time? The sustainability and nonsustainability of three decades of secondary school change and continuity. *Educational administration quarterly*, 42(1), 3–41.
- Herzig, B. (2014). *Wie wirksam sind digitale Medien im Unterricht?* [How effective are digital media in the classroom?]. Bertelsmann Stiftung. [https://www.researchgate.net/profile/Bardo\\_Herzig/publication/269669941\\_Wie\\_wirksam\\_sind\\_digitale\\_Medien\\_im\\_Unterricht/links/549146110cf2d1800d87d673/Wie-wirksam-sind-digitale-Medien-im-Unterricht.pdf](https://www.researchgate.net/profile/Bardo_Herzig/publication/269669941_Wie_wirksam_sind_digitale_Medien_im_Unterricht/links/549146110cf2d1800d87d673/Wie-wirksam-sind-digitale-Medien-im-Unterricht.pdf).
- Hibbert, P. (2013). Approaching reflexivity through reflection: Issues for critical management education. *Journal of Management Education*, 37(6), 803–827.
- Hill, R., & Myatt, T. (2010). *The economics anti-textbook: a critical thinker's guide to microeconomics*. Zed Books.
- Hirschman, D., & Berman, E. P. (2014). Do economists make policies? On the political effects of economics. *Socio-Economic Review*, 12(4), 779–811.
- Hodgson, G. M. (2004). *The evolution of institutional economics*. Routledge.
- Jappelli, T. (2010). Economic literacy: An international comparison. *The Economic Journal*, 120(548), 429–451. <https://doi.org/10.1111/j.1468-0297.2010.02397.x>.
- Jeannin, L., & Ojo, E. (2021). Culturally responsive differentiated instruction: What lessons for economics lecturers in South Africa?. In M. Cross, C. Long, S. Ndlovu & P. Nyoni (Eds.), *Transformative Curricula, Pedagogies and Epistemologies: Teaching and Learning in Diverse Higher Education Contexts*, 11 (pp. 81–89). Brill.
- Joshi, M., & Joshi, D. (2020). Why it's time to take central banks' digital currencies seriously. <https://europeansting.com/2020/08/14/why-its-time-to-take-central-banks-digital-currencies-seriously> [22.09.2022].
- Jucker, R. (2002). *Our common illiteracy: Education as if the Earth and people mattered* (Vol. 10). Peter Lang.
- Koehler, M. J., Mishra, P., & Cain, W. (2013). What is technological pedagogical content knowledge (TPACK)? *Journal of Education*, 193(3), 13–19.
- Lynch, R., McCormack, O., & Hennessy, J. (2017). *Exploring the position of curriculum studies across the continuum of teacher education in Ireland*. *Irish Educational Studies*, 36(4), 439–456.
- Marboub, D., Abbasi, T., Maasmi, F., Omar, I. A., Debe, M. S., Salah, K., . . . Ellahham, S. (2020). Blockchain for COVID-19: Review, opportunities, and a trusted tracking system. *Arabian Journal for Science and Engineering*, 1–17.
- Meyer, J., & Land, R. (2003). Threshold concepts and troublesome knowledge: Linkages to ways of thinking and practising within the disciplines. In C. Rust (Ed.), *Improving student learning: Theory and practice—ten years on* (pp. 412–424). Centre for Staff and Learning Development.
- Nakamoto, S. (2008). *Bitcoin: A peer-to-peer electronic cash system*. bitcoin. <http://www.bitcoin.org/bitcoin.pdf>
- OECD. (2020). COVID-19 and global capital flows. <http://www.oecd.org/coronavirus/policy-responses/covid-19-and-global-capital-flows-2dc69002/> [03.07.2020].
- Ojo, E. (2016). *On teaching economics 1: A qualitative case study of a South African university*. (Doctor of Philosophy, Ph.D), Faculty of Humanities, University of the Witwatersrand, Johannesburg, South Africa.

- Ojo, E., Booth, S., & Woollacott, L. (2019). Faculty's conceptions of teaching introductory economics in higher education: A phenomenographic study in a South African context. *International Review of Economics Education*, 30, 100–134.
- Ojo, E., & Jeannin, L. (2016). *The way economics is taught needs an overhaul: a South African case study*. The Conversation. <https://theconversation.com/the-way-economics-is-taught-needs-an-overhaul-a-south-african-case-study-67260s>.
- Olafson, L., & Schraw, G. (2006). Teachers' beliefs and practices within and across domains. *International Journal of Educational Research*, 45(1–2), 71–84.
- Ongeri, J. D. (2017). Instruction of economics at higher education: A literature review of the unchanging method of “talk and chalk”. *The International Journal of Management Education*, 15(2), 30–35.
- Peneder, M. (2022). Digitization and the evolution of money as a social technology of account. *Journal of Evolutionary Economics*, 32(1), 175–203.
- Peng, T. (2020). *China's blockchain service network integrates three more public chains*. <https://cointelegraph.com/news/china-blockchain-service-network-integrates-three-more-public-chains>. Cointelegraph. [02.10.2020].
- Rassuli, A., & Manzer, J. P. (2005). “Teach us to learn”: Multivariate analysis of perception of success in team learning. *Journal of Education for Business*, 81(1), 21–27.
- Ring, M., & Brahm, T. (2020). Logical pictures in secondary economic education: textbook analysis and teacher perception. *RISTAL. Research in Subject-matter Teaching and Learning*, 3, 86–107.
- Sahlberg, P. (2010). The secret to Finland's success: Educating teachers. *Stanford Center for Opportunity Policy in Education*, 2, 1–8.
- Salemi, M. K. (2005). Teaching economic literacy: Why, what and how. *International Review of Economics Education*, 4(2), 46–57.
- Shawer, S. (2010). Classroom-level teacher professional development and satisfaction: Teachers learn in the context of classroom-level curriculum development. *Professional Development in Education*, 36(4), 597–620.
- Shulman, L. S. (1986). Those who understand: Knowledge growth in teaching. *Educational Researcher*, 15(2), 4–14.
- Siegfried, J. J., & Fels, R. (1979). Research on teaching college economics: A survey. *Journal of Economic Literature*, 17(3), 923–969.
- Statista. (2020). *Cryptocurrency market capitalization 2013–2019*. Statista. <https://www.statista.com/statistics/730876/cryptocurrency-market-value/> [22.06.2021].
- UNESCO. (2020). *1.3 billion learners are still affected by school or university closures, as educational institutions start reopening around the world, says UNESCO*. <https://en.unesco.org/news/1.3-billion-learners-are-still-affected-school-university-closures-educational-institutions> [29.04.2020].
- Van Treeck, T., & Urban, J. (2016). *Wirtschaft neu denken. Blinde Flecken der Lehrbuchökonomie* [Rethinking the economy. Blind spots of textbook economics]. iRights Media.
- Venkatesan, M. (2021). Making economics relevant: incorporating sustainability. In W. L. Filho, A. L. Salvia & F. Frankenberg (Eds.), *Handbook on Teaching and Learning for Sustainable Development* (pp. 350–365). Edward Elgar.
- Walstad, W. B., Rebeck, K., & Butters, R. B. (2013). The test of economic literacy: Development and results. *Journal of Economic Education*, 44(3), 298–309.
- Walstad, W. B., & Soper, J. C. (1988). What is high school economics? TEL revision and pretest findings. *Journal of Economic Education*, 19(1), 24–36.
- World Bank. (2022). *Global growth to slow through 2023, adding to risk of 'hard landing' in developing economies*. *The World Bank Group*. <https://www.worldbank.org/en/news/press-release/2022/01/11/global-recovery-economics-debt-commodity-inequality> [20.10.2022].
- World Commission on Environment and Development (WCED). (1987). *Our Common Future*. Oxford Paperbacks.



## Chapter 10

### Shared Perspectives from Two Universities on Teaching Electricity: Lessons for Science Teacher Education

Jan-Philipp Burde, John Bradley and Peter Moodie

*Hardly any other discovery has had such a lasting impact on modern civilization as the discovery of electricity. The teaching of electricity is therefore not only part of science curricula in South Africa and Germany, but also throughout the world. However, it is acknowledged in schools and universities worldwide that the topic represents a great challenge to students and teachers alike. Although there is an abundance of educational research on students' difficulties with DC circuits and electrochemical cells, this research has rarely been brought together. In this chapter, we shall focus on the question of whether considering these two bodies of work together can give us new insights, and suggest new approaches for designing science teacher education at university.*

*As DC circuits have traditionally been a physics topic and electrochemical cells a chemistry topic, many educational institutions and policy makers maintain a silo mentality. Even when the teaching subject is physical science (as in South Africa), rather than physics and chemistry (as in Germany), teaching does not, in general, succeed in helping students understand how cells and circuits constitute an electrical system. In this chapter, we will first provide an overview of the science teacher preparation programs at the University of Tübingen and the University of the Witwatersrand. We proceed by looking more closely at the physics and chemistry of electric circuits, before providing an analysis of students' typical conceptual difficulties with cells and circuits. Drawing on our experiences in the two contexts, Wits and Tübingen, we discuss possible pedagogical implications for science teachers-in-training. In particular, we propose that teacher education about electricity should over-*

<http://dx.doi.org/10.15496/publikation-76372>



*come the silo mentality and emphasize that cells and circuits constitute an electrical system, focus more on the concept of voltage by examining how voltage is created and maintained by cells, and provide students with powerful models and analogies that help visualize potential differences in circuits.*

## 1 Introduction

Ever since, some two centuries ago, Volta constructed his “pile” and observed current electricity, the world has been changed by the consequences, and is still being changed. Explaining the pile's working and the phenomenon of current electricity took many years of research and required the parallel development of the atomic theory, which was re-launched by Dalton. Today, cells and circuits are standard topics in school curricula around the world, and science teachers try to explain them at a suitable level. Likewise, the preparation of new science teachers necessarily pays attention to these topics and how best to teach them.

These educational tasks have proved difficult. There is abundant evidence around the world that science teachers and their students often do not fully understand the phenomena involved (Burde, 2018; Duit, 2009; McDermott & Shaffer, 1992; Pardhan & Bano, 2001). There are numerous reasons for these conceptual difficulties, ranging from an unnecessary focus on current rather than voltage (Cohen et al., 1983), to the fact that the physical processes in circuits are generally hard to imagine, as they elude direct perception (Burde & Wilhelm, 2017). In addition to the abstract nature of electric circuits, the conceptual difficulties involved in voltage, as well as cells and their role in circuits, may also be attributed to the fact that DC circuits are traditionally a physics topic and electrochemical cells a chemistry topic.

These problems are known in both our institutions. Research efforts have been conducted to overcome them. The approaches have been somewhat different in emphasis, which can be attributed to the different school and teacher education curricula followed in the two countries. While research at Wits aims to help students understand the interaction between the physics and chemistry components in circuits, research at Tübingen primarily focusses on approaches that provide students with a better understanding of voltage.

In this chapter of the book “Teacher Education in South Africa and Germany. Shared Perspectives”, we shall briefly compare the science teacher education curricula at our two universities, give a brief introduction to the physics and chemistry of electric circuits, and describe students' conceptual difficulties with cells and circuits. Based on

these considerations, we bring together educational research on cells and circuits, which has rarely been done before. In particular, we propose that teacher education about electricity should focus more on the concept of voltage, e.g., by looking more closely at how voltage is created and maintained by cells. Teaching should emphasize that cells and circuits constitute an electrical system. Furthermore, we suggest that prospective teachers be aware of typical misconceptions (sometimes called “alternative conceptions”), as well as effective models and analogies that take these learning difficulties into account, in order to help students develop a better qualitative understanding of circuits.

## 2 Science teacher preparation

### 2.1 At the University of the Witwatersrand (Wits)

Wits University is a medium-sized, urban university with faculties of science, engineering and health sciences. However, these faculties play no part in the preparation of science teachers, since all school-teacher preparation (content and methodology) falls under the School of Education within the Faculty of Humanities. Furthermore, the School of Education is located on a campus separate from those housing the other faculties mentioned. The result of this physical and administrative arrangement is that there is little contact between the staff teaching future science teachers and the staff of other faculties with cognate subject interests.

The following remarks provide context for understanding the 4-year Bachelor of Education curriculum followed by student science teachers. In the first two years, the science content and method courses relate strongly to the grade 4–9 Natural Sciences school curriculum, even if a student intends to teach grade 10–12 Physical Sciences or Life Sciences. It is only in the 3<sup>rd</sup> and 4<sup>th</sup> years that students aiming at the latter qualification engage with the grade 10–12 subject content and method. Little time is left for developing in-depth knowledge of the school science content in these circumstances.

The national school curriculum offers Physical Sciences as a subject for grades 10–12, but the subjects physics and chemistry are not offered separately. The subject matter content of the Physical Sciences curriculum is quite distinctly divided into a physics and a chemistry component, and the final matriculation exam comprises two papers: one devoted to physics and one to chemistry. The same kind of separation is maintained in the Physical Sciences content courses in the 3<sup>rd</sup> and 4<sup>th</sup> year of the B. Ed.



curriculum. This, of course, is consistent with the B. Ed.'s strong emphasis on preparing students to teach the existing school subject.

The Wits authors' current research is in promoting the interaction between the physics and chemistry components of the Physical Sciences courses in the B. Ed. curriculum. Cells and circuits are the primary topics in this research (Bradley et al., 2019a, 2019b).

## 2.2 At the University of Tübingen

Tübingen University, founded in 1477, is not only one of the oldest, but also one of the strongest research universities in Germany. With more than 27,000 enrolled students, it is a mid-sized university and is located in the state of Baden-Württemberg, in the south-west of Germany. Teacher education is organized by the Tübingen School of Education (TüSE), which coordinates the different programs of study across the faculties of the university. While prospective primary school teachers (for grade 1 to 4) and prospective lower secondary school teachers (grade 5 to 10) receive their training at specialized Universities of Education in the state of Baden-Württemberg, teacher training at Tübingen University is aimed at prospective Gymnasium teachers intending to teach grade 5 to 13. In Tübingen, students complete a course tailored specifically to the needs of prospective teachers, leading to a Bachelor of Education (B. Ed.) or Master of Education (M. Ed.). Since the natural sciences at most German schools are usually not taught in the form of an integrated subject “science”, but as separate subjects like chemistry, biology, and physics (KMK, 2020), teacher training at the University of Tübingen is also subject-specific.

As a result, future physics teachers mostly attend the same physics lectures and seminars organized by the Department of Physics as their peers studying for a Bachelor of Science (B. Sc.). As part of their course, future teachers not only specialize in two subjects (e.g., physics and mathematics) to develop their content knowledge (CK), but also attend seminars that are specifically designed to advance their pedagogical knowledge (PK) as well as their pedagogical content knowledge (PCK) (TüSE, 2019). In Tübingen, lectures and seminars aimed at increasing students' content knowledge (CK) are held by lecturers of the respective departments, e.g., the Department of Physics. Consequently, students at Tübingen University receive a well-founded education in physics that goes beyond the typical school content, but may not necessarily have a strong understanding of chemistry, as many teaching students in Tübingen have math as their second subject. This difference between the two teacher education curricula also reflects the differences between the school systems in Germany and South Africa. In the semi-

nars designed to enhance the prospective physics teachers' PCK, organized by the Physics Education Research Group, one area of focus lies in familiarizing future physics teachers with typical misconceptions, e.g., in the fields of mechanics, optics and electricity, and in discussing effective, research-based approaches to help secondary school students develop an adequate conceptual understanding, e.g., of electric circuits.

### 2.3 Research in electricity concepts in the two curricular contexts

The different curricular contexts in which the authors of this chapter teach naturally have an influence on the research that attracts their attention. Given that no integrated subject “science” exists at the University of Tübingen, as physics and chemistry are taught here as separate subjects, its research primarily focusses on how to provide students with a better conceptual understanding of the physics of, for example, DC circuits. In this case, research projects in Tübingen focus on identifying students' misconceptions about DC circuits, ways to foster a better conceptual understanding of voltage, as well as effective models and analogies to better illustrate key aspects of simple DC circuits.

In the Wits context, the 3<sup>rd</sup> and 4<sup>th</sup> year courses are titled Physical Science, and equal time in each year is given to physics and chemistry topics. Furthermore, following the secondary school curriculum structure, the physics and chemistry topics in the B. Ed. at Wits are presented almost entirely as separate topics: the chemistry topic of electrochemical cells and the physics topic of DC circuits. The research focus here is on the understanding of cell chemistry that can result in understanding these circuits better.

In sections 3, 4 and 5 of this chapter, separate sub-sections are devoted to chemistry and physics issues in understanding what is, in fact, one physico-chemical system. These sub-sections come from Wits and Tübingen respectively, and reflect the different research interests of the two institutions.

## 3 The physics and chemistry of electric circuits

Before discussing students' conceptual difficulties with cells and circuits, e.g., with regard to current and voltage, it is important to first give a brief introduction to the physics and chemistry of electric circuits. The following sections will therefore explain the role of potential difference in circuits and briefly describe how a cell works from a chemical perspective.

### 3.1 What happens inside a cell?

A short answer is: there is a chemical reaction. Chemical reactions usually involve two reactants. The reaction occurs when the different reactant molecules collide with sufficient vigor. As the reaction takes place, there is an energy change: usually the products have a lower potential energy than the reactant molecules and energy is transferred to the surroundings. Such reactions are called exothermic. This energy change (usually measured in kJ/mol) may be said to be the driving force of the reaction (neglecting entropy for simplicity). One class of reaction involves electron transfer between the different molecules. These are called redox reactions. It is only this class of reaction that can be used in an electrochemical cell.

In the cell, the reactants are kept separate from one another. One reactant is concentrated around one terminal and the other reactant is concentrated around the other terminal. The reactant that is the source of electrons is located around the  $-$  terminal, while the reactant that receives electrons is located around the  $+$  terminal. The outer casing of commercial cells always shows  $-$  and  $+$  signs at the corresponding terminals. When the two terminals are connected by a metal wire, which is a conductor of electrons, electron transfer can take place. We say there is an electric current in the conductor; this may be described as a flow of electrons. In this context, the driving force originating in the cell is described as the emf (electromotive force) and is measured in volts (J/C). Commercial cells usually have this quantity shown on the outer casing (e.g., 1.5 V). The casing does not show the current because it depends on the circuit in which the cell is incorporated. The current reflects the rate of the chemical reaction inside the cell, so the rate varies with the circuit.

Inside the cell, there are additional changes. The electron transfer results in positive charges accumulating inside the cell around the  $-$  terminal and negative charges accumulating around the  $+$  terminal. Movement of positive ions away from the  $-$  terminal and negative ions away from the  $+$  terminal takes place to maintain a uniform distribution of positive and negative charges in the cell electrolyte. This two-way ion movement forms part of the continuity of current through the system in operation, the electronic transfer external to the cell being the more obvious part of this.

### 3.2 What is the role of voltage in circuits?

When hearing the term “electric circuit”, most people think of electric current, which is often associated with the mental picture of a flowing river. Even if this association is not wrong, there is another physical quantity that is at least as import-

ant as the electric current: voltage. However, in contrast to current, most people lack a qualitative understanding of voltage (Burde, 2018; McDermott & Shaffer, 1992; Rhöneck, 1986). This is problematic for at least two reasons: firstly, voltage plays a more important role in everyday life than current. Every child learns that high voltage is dangerous and that you should never stick your fingers into an electric socket, as it works with a voltage of 230 V. In addition, voltage specifications can be found on everyday objects, e.g., cells marked as 1.5 V. Thirdly, voltage also plays a central role from a physical point of view, since there is only a current through an electric device if a voltage – created and maintained by the chemical reaction in the cell – is applied to it. This raises the question of what voltage is and what role it plays in electric circuits.

As described at the beginning, batteries maintain a constant voltage between their two terminals. This simple statement contains two important aspects: firstly, that batteries are not a source of a constant current, but of a constant voltage; and secondly, that voltage is a physical quantity that only occurs between two distinct points, in this case between the two terminals of a battery. Without going into too much detail, this example already shows that voltage is a differential quantity, therefore the voltage  $V_{AB}$  between point A and point B is defined as the potential difference between the electric potential at point A and B, in this case between the terminals of the battery:

$$V_{AB} = \Phi_B - \Phi_A$$

$V_{AB}$ : Voltage between point A and B  
 $\Phi_A$ : Electric potential at point A  
 $\Phi_B$ : Electric potential at point B

If a wire is attached to each battery terminal, the electric potential in each wire is the same as at its battery pole. In an open circuit, this means that the potential difference between the unconnected ends of the two wires is the same as the potential difference between the two battery terminals. If these two previously unconnected wires are attached to a light bulb, it is this potential difference that causes the electric current to go through the light bulb. For the purpose of this chapter, it is important not only to be aware of this cause-effect-relationship between voltage and current, but also to realize that the higher the voltage, the higher the electric current through the light bulb.

## 4 Students' conceptual difficulties with cells and circuits

The science education literature clearly shows that DC circuits represent a great challenge for many learners (Burde, 2018; McDermott & Shaffer, 1992; Rhöneck, 1988; Waltner et al., 2009). This section therefore provides an overview of three misconceptions of cells and circuits that we think should be part of a modern teacher education curriculum. Based on our shared observation at Wits and Tübingen that these misconceptions are widespread among teaching students, we believe that this calls for the development of PCK within the framework of national school curricula (Goes et al., 2020).

However, because of the mindset and institutional structures that treat chemistry and physics as separate subjects, school curricula and the teacher preparation curricula may in fact be contributing to the misconceptions described in this section. The consequence of this silo mentality is that chemistry teachers deal with electrochemical cells and physics teachers with DC circuits, and each does so with little reference to the other. The latter are uneasy teaching about how the cell works, partly out of ignorance and partly out of conformity with curriculum specifications. At the same time, chemistry teachers often take little interest in the “external circuit”, focusing instead on the significance of electrode potentials and their interpretation.

Moreover, language and terminology are important for helping students develop a good understanding of circuits. Based on our experience at Wits and Tübingen, students should be made aware of ambiguous language that can cause confusion. For example, the terms cell and battery are not interchangeable. The full name for a battery is a battery of cells, and they are in series. Similarly, the electric current represents a flow of charges. The charges (be they ions or electrons) may be said to flow, but not the current. Hence current can neither “flow” nor be stored.

### 4.1 Misconceptions regarding the cell

Looking at the misconceptions about DC circuits, it becomes clear that, among other factors, they can also be attributed to an unwillingness to understand how the cell works. Regular teaching does not explain circuit phenomena adequately if cells are simply described as a store of energy, a source of energy, a source of voltage, or a source of current. Such descriptions may be correct, but unless they are investigated more concretely, learners will make up the details for themselves. And, like the scientists of the early 19<sup>th</sup> century, they will often get them wrong.

Teachers of chemistry are often astonished by the ideas their students have about elec-

trochemical cells. Some of these were reported many years ago by Garnett and Treagust (1992), and Ogude and Bradley (1994). A more recent report by Sesen and Turhan (2013) listed more than 20 misconceptions, and research into students' understanding of electrochemistry concepts continues (Karamustafaoğlu & Mamlok-Naaman, 2015). On the whole, chemistry teachers focus mostly on voltaic cells and their equilibrium properties, emphasizing electrode potentials and their application and interpretation. Most curricula identify redox reactions as the type of reaction to be found in cells, and in many senior secondary schools, the cell emf is explicitly related to the free energy change of the reaction. Electric current is more prominent in the teaching of electrolytic cells and the link is between the amount (mol) of chemical change and the quantity (C) of electricity. This link, studied by Faraday in the 1830s, was key evidence that there is a particle of electricity, which was later given the name electron. The Faraday constant,  $F$  (96 485 C/mol), indicates his name as the discoverer of the link. One of the most widespread of all misconceptions is a product of the emphasis on the electric current in, and continuity of, the electric circuit. This leads to the following misconceptions:

- ▶ Electrons flow not only through the electric circuit, but also through the cell itself (Ogude & Bradley, 1994).
- ▶ The electrons passing through the cell are re-energized as they do so, in ways that are not satisfactorily explained.
- ▶ The current is the cause of potential differences in the circuit (Cohen et al., 1983).
- ▶ The cell stores electric current and releases it when the circuit is completed.

None of these is true. Their origin is probably in teaching and learning about circuits rather than cells. Some models used in teaching about DC circuits explicitly state or imply the first two of these misconceptions (Stocklmayer & Treagust, 1994). Other models simply ignore the inner workings of the cell. By paying more attention to the role and functioning of a cell in teaching electric circuits at an early stage, such misconceptions could be avoided or at least ameliorated.

Another area of confusion is linked with the meaning of the + and – symbols when they appear in diagrams and are described as positive and negative. The terminal signs suggest they have charges and use of the descriptors “positive” and “negative” reinforce this interpretation. These are sometimes invoked in accounting for the direction of electron flow in the external circuit, e.g., negative electrons move towards the + terminal. Unfortunately, within the cell, the + terminal is the external manifestation of the cathode inside the cell, towards which cations move. These cations may or may not accept electrons from

the cathode, depending on the presence of neutral molecule competitors. In short, the idea that the + terminal has a positive charge may have a simple appeal, but it is untenable. Finally, the cell is described as a store of energy, implying that in some form or other, energy is trapped inside the cell. This view echoes the old phlogiston theory, which was overthrown primarily through the work Lavoisier carried out at around the time that Volta made his pile. The cell may be described as a source of energy, but it should be clarified that it is the redox reaction inside it that is the actual source of energy (Schmidt-Rohr, 2018).

#### 4.2 Problems understanding the circuit as a system

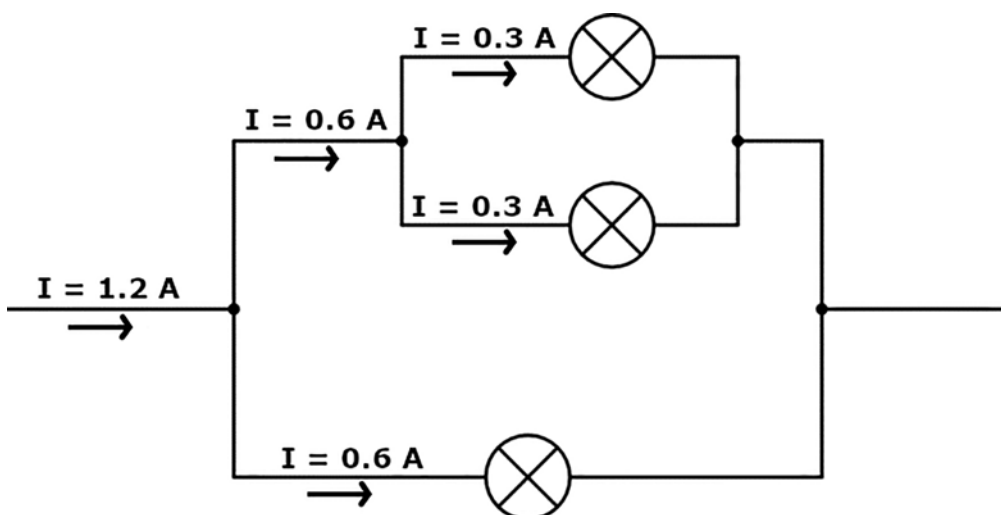

*Figure 1 The circuit diagram shows the distribution of current as assumed by students with “local reasoning”. All light bulbs in the circuit have the same resistance.*

From a physics perspective, a major difficulty for students is understanding that the electric circuit constitutes an interconnected system. Students tend to analyze electric circuits exclusively from the perspective of the charge flow believed to travel sequentially around the circuit, component by component (Shipstone, 1984). In a parallel circuit like that shown in Fig. 1, for example, students often believe that the electric current divides into equal parts at each junction – completely ignoring the effects of the other components in the circuit and the role of potential differences. As a result of this particular misconception, often referred to as “local reasoning” (Closset, 1984), students assume that the two upper bulbs in the parallel circuit in Fig. 1 should shine less brightly than the lower bulb, when in fact all have the same brightness. This example also illustrates the problems that arise if current rather than voltage is the students’

primary concept. However, if students were taught to first analyze the potential differences (p.d.) in the circuit, they would realize that the p.d. is the same across all three light bulbs. Since the same p.d. leads to the same current through identical light bulbs, all three light bulbs in Fig. 1 shine equally brightly.

#### 4.3 Voltage as a property of the electric current

In physics education research, voltage has proven to be a quantity that presents many learners with particular difficulties, as it is often perceived as a property or component of the electric current rather than an independent physical quantity, even after instruction (Burde, 2018; Rhöneck, 1986). In particular, research has shown that students often think of voltage as the “force” or the “strength” of the electric current. This kind of reasoning about electric circuits is problematic for at least two reasons: firstly, because students fail to realize that voltage, as a potential difference, represents an independent physical quantity that refers to two points in a circuit and that can exist independently of an electric current (Maichle, 1982). As a result, students wrongly believe that, in a simple circuit attached to a battery, you can measure the voltage at a closed switch but not across an open switch (Rhöneck, 1981). Second, some students believe that the electric current simply exists in the circuit, seeing no need for a cause-and-effect-relationship between voltage and current (Cohen et al., 1983). The students' development of an independent concept of voltage is further complicated by the often extensive quantitative study of Ohm's law in the classroom. In particular, there is a danger that the traditional focus on the formula  $V = RI$  strengthens the students' misconception that voltage is not an independent physical quantity, but a property of the electric current, since the formula seems to suggest that voltage  $V$  is always proportional to the electric current  $I$  (Muckenfuß & Walz, 1997; Rhöneck, 1988).

### 5. Towards an understanding of circuits as physico-chemical systems

Whilst there is much of interest to be learnt from the perspective of physics and that of chemistry, we are convinced that understanding DC circuits requires both perspectives. Drawing on our research and different curricular experiences at Wits and Tübingen, we suggest overcoming the traditional silo mentality when discussing electrochemical cells and electric circuits in science teacher education, and helping prospective science teachers understand circuits as physico-chemical systems. By integrating the two perspectives, learners in schools and in teacher education



courses can develop a more holistic understanding. This suggested integration by the authors of Wits and Tübingen is highly relevant for science teacher education, as it should result in far fewer alternative conceptions arising. Such an ambition is, in principle, readily achievable in the context of a physical science curriculum, as in South Africa. Where separate physics and chemistry curricula are in force, as is the case at Tübingen University, this may be less easy, but certainly not impossible. Having reached a shared view on desirable developments and research in teaching about cells and circuits, the following sub-sections, 5.1 and 5.2, describe the current thrusts of our two groups.

#### 5.1 Design of an interdisciplinary topic in a B. Ed. course for prospective teachers of Physical Sciences – a view from Wits

Students in this degree bring with them the knowledge about cells and circuits they acquired in school, much of it fragmentary and some of it erroneous. They would most likely be taught something about cells and circuits in the 3<sup>rd</sup> and/or 4<sup>th</sup> year of the B. Ed. curriculum. The chemistry content and the physics content are taught separately and usually in different years. These facts and the preceding analysis has led us (Bradley & Moodie, 2021) to the following design of a proposed interdisciplinary topic, probably most suited to the 3<sup>rd</sup> year of the B. Ed.

1. Sources of Energy and How They Transfer Energy  
Combustion of fuels and using cells and batteries
2. Why is Combustion of Fuels a Source of Energy?  
Differences in electronegativity of atoms results in exothermic redox/electron-transfer reactions
3. Cells as a Source of Energy  
Redox reactions in a hydrogen fuel cell and in a traditional 1.5 V cell
4. How Can Electron Transfer Take Place Through an External Circuit?  
Reductant (electron donor) separated from oxidant (electron acceptor), electron transfer externally and ion migration internally. The + and – symbols on the cell.
5. How the Source of Energy is Quantitatively Described  
Volts and kJ/mol: the link explained

We envisage that this topic would be a worthwhile basis for teaching more purely chemistry concepts (standard electrode potentials, Nernst equation) and more purely physics concepts, as exemplified in the following sub-section 5.2. It would also support teaching about alternative energy sources and energy storage. At the time of writing, it has not yet been possible to debate the teaching of this topic with our colleagues, primarily due to the additional stresses resulting from the COVID-19 pandemic.

### 5.2 New approaches to teaching about circuits for prospective teachers of physics – a view from Tübingen

Most students enrolled in the physics teacher course at Tübingen University do not choose chemistry as their second subject. However, as prospective physics teachers, they mostly attend the same physics lectures as their peers studying for a Bachelor of Science (B.Sc.). As a result, students in Tübingen usually have well-founded content knowledge in physics, but not in chemistry. Despite their advanced understanding of electricity, for instance, many students still hold various alternative conceptions of electric circuits. Considering their lack of content knowledge in chemistry, it is necessary to provide prospective physics teachers with an understanding of the important role that cells play in electric circuits, as well as in the electrochemical processes taking place inside these cells. Furthermore, it is essential to enhance their PCK on simple circuits by familiarizing them with typical alternative conceptions and introducing them to effective, research-based teaching approaches. Considering that educational research on cells and circuits has rarely been brought together, and taking typical alternative conceptions into account, teacher education at institutions where separate physics and chemistry curricula are in force, such as Tübingen University, may be improved if the following aspects are taken into account:

- A. Discussing cells before circuits
- B. Discussing open circuits before closed circuits
- C. Illustrating potential differences using effective models and analogies

The following sections will elaborate the rationale for each of these three aspects based on research by the Tübingen-based author, exchanges with the authors from Wits, and findings from science education research of the past decades.

### 5.2.1 Discussing cells before circuits

Building on the ideas of Cohen et al. (1983), Psillos et al. (1988), Burde (2018) and their “voltage first approach”, cells should not be treated as a black box at universities with separate physics and chemistry curricula, but as the starting point for a more in-depth study of circuits. It should be pointed out that the configuration of materials and substances inside the cell will enable it to produce a constant voltage as soon as its terminals are connected, but its current output will depend on the resistance in the connection. This is particularly important as many students think of cells as a source of constant current rather than constant voltage. Studying the electrochemical processes in a cell at the beginning of a unit on circuits could also counteract the development of the alternative conception that electrons do not only flow through the circuit, but also flow through the cell, getting re-energized along the way.

Another argument in favor of studying the chemical processes of cells is that it will help students better understand the role of ions and electrons in circuits. Such an approach not only facilitates an understanding of the Drude model (Drude, 1900), helping students develop deeper insight into the conduction processes (e.g., the collisions between electrons and the ion lattice), it would also make them aware of how closely chemical and physical aspects of the electric circuit are interrelated. Overcoming the traditional silo mentality between chemistry (teaching only the working of cells) and physics (teaching only the working of circuits) at the beginning of the topic “electric circuits” becomes particularly important in view of the increasing socio-economic prominence of batteries in our world, e.g., in smartphones and electric cars.

### 5.2.2 Discussing open circuits before closed circuits

Since the electric current often dominates students' thinking of electric circuits (Cohen et al., 1983; Maichle, 1982; Rhöneck, 1986), it is important to focus on open rather than closed circuits after studying how cells work. The reason for this is that in closed circuits, voltage and current, according to the formula  $V = R I$ , only ever occur simultaneously. This may make it more difficult for students to develop an independent concept of voltage and instead foster the alternative conception that voltage is a property of the electric current. As there is no current in open circuits, such circuits are ideal for illustrating that voltage is an independent physical quantity (Burde & Wilhelm, 2021). Furthermore, such an approach would be consistent with the ideas

of Cohen et al. (1983) and Psillos et al. (1988), who, considering that the electric current often dominates teaching, called for a curriculum that starts with the concept of voltage rather than current, as “first impressions are strong and may impede a later, more rigorous, study of electricity” (Cohen et al., 1983, p. 411).

### 5.2.3 Illustrating potential differences using effective models and analogies

Given the importance of conceptually understanding voltage as a potential difference for an adequate understanding of electric circuits, it is important that science teachers-in-training are aware of models and analogies that have proved effective in science education research. In particular, such models and analogies should help students understand three important aspects of circuits: firstly, that voltage refers to two points in a circuit; secondly, that there is a current only when a voltage is present, and thirdly, that electric circuits represent interconnected systems, which cannot be exclusively analyzed from the perspective of charge flow.

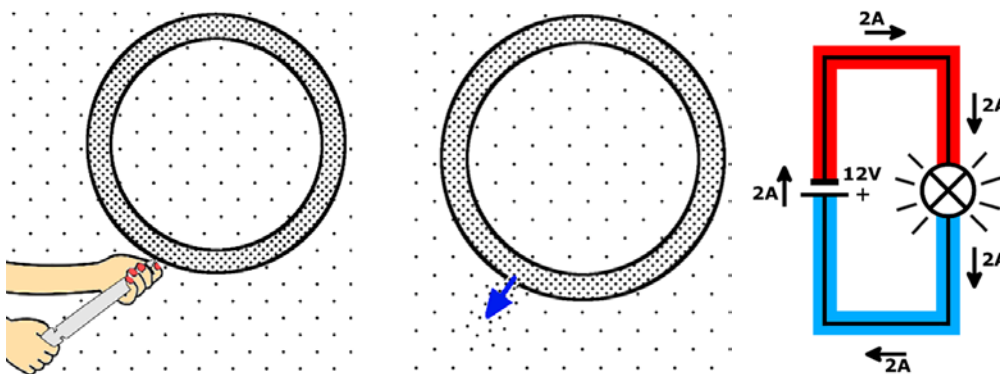

*Figure 2 Just as air pressure differences cause air flow (left) from an inflated bicycle tire (blue arrow), electric pressure differences cause electron flow through a light bulb (right)*

A promising way to help students develop a qualitative understanding that voltage refers to two points in a circuit and that there is a current only when a voltage is present is the use of an air pressure analogy (Steinberg & Wainwright, 1993). By comparing potential differences with air pressure differences in electric circuits, students can relate the rather abstract physical quantities “electric potential” and “electric potential difference” to their everyday experiences. In particular, students can have first-hand experience with air pressure using everyday objects such as air mattresses or bicycle tires to learn that air pressure differences are the cause of air flow (see Fig. 2). In the

next step, their understanding of air pressure can be transferred to electric circuits, helping them develop a qualitative understanding of voltage by comparing the electric potential in circuits to an “electric pressure”. It can then be argued that just as air pressure differences cause air flow, electric pressure differences cause electron flow, e.g., through a light bulb. By color-coding the “electric pressure” in the wires as shown in Fig. 2, students can easily identify potential differences in various circuits.

Moreover, a key advantage of this “electric pressure” model in combination with color-coding is that it helps make voltage rather than current the students' primary concept when analyzing electric circuits. This may, for example, reduce students' tendency to reason locally and help them understand that the electric circuit represents an interconnected system (Burde & Wilhelm, 2021). Furthermore, the suggested approach helps students develop an intuitive understanding of the cause-and-effect relationship between voltage and current in circuits.

## 6 Visions for science teacher education in an electrical future

In this chapter we have focused on our research on students' understanding of voltage, cells and circuits as physico-chemical systems. However, these aspects point to a broader concern, namely that students should begin to see the world as an interconnected set of systems that affect each other. The global efforts to end the world's dependence on energy from fossil resources and move toward a more sustainable future following the Paris Climate Agreement (United Nations, 2015) has created a focus on renewable energy systems, such as photovoltaic cells and wind turbines. Batteries and fuel cells using hydrogen produced via these systems are now critically important technologies. From an educational perspective, it is essential that these more recent developments also find their way into school and university curricula.

The UN's (United Nations, 2021) call for “Education for Sustainable Development” demands a response from those engaged in science teacher education. Prospective science teachers should therefore not only have adequate content knowledge, but also be aware of its relevance for society and everyday life by addressing STS (“Science, Technology, and Society”) aspects of electricity (Solomon & Aikenhead, 1994). Education for Sustainable Development must be designed on such principles, which means making the walls between disciplinary silos more permeable.

## Literature

- Bradley, J. D., Khulu, S., Moodie, P., & Mphahlele, M. (2019a). Pre-service teachers' misconceptions about current and potential difference in electric circuits—using microscience kits in a POE activity. *African Journal of Chemical Education*, 9(3), 75–96.
- Bradley, J. D., Khulu, S., Moodie, P., & Mphahlele, M. (2019b). Using microscience kits to address a student-teacher misconception in electric circuits: at the interface between chemistry and electricity. *African Journal of Chemical Education*, 9(3), 37–45.
- Bradley, J. D., & Moodie, P. (2021). A systemic approach to teaching and learning about electrical cells and circuits using two big ideas of science. *African Journal of Chemical Education*, 11(1), 1–14.
- Burde, J. P. (2018). *Konzeption und Evaluation eines Unterrichtskonzepts zu einfachen Stromkreisen auf Basis des Elektronengasmodells* [Conception and evaluation of a teaching concept for simple electric circuits based on the electron gas model], Vol. 259. Logos-Verlag.
- Burde, J. P., & Wilhelm, T. (2017). Modelle in der Elektrizitätslehre [Models in electricity science]. *Unterricht Physik*, 28(157), 8–13.
- Burde, J. P., & Wilhelm, T. (2021). Teaching electric circuits with a focus on potential differences. *Physical Review Physics Education Research*, 6(2).
- Closset, J. L. (1984). Woher stammen bestimmte "Fehler" von Schülern und Studenten aus dem Bereich der Elektrizitätslehre? Kann man sie beheben? [From where do certain "mistakes" made by pupils and students in the field of electricity come from? Can they be fixed?]. *Der Physikunterricht*, 18(2), 21–31.
- Cohen, R., Eylon, B., & Ganiel, U. (1983). Potential difference and current in simple electric circuits: A study of students' concepts. *American Journal of Physics*, 51(5), 407–412.
- Duit, R. (2009). *Bibliography—STCSE: Students' and teachers' conceptions and science education*. IPN—Leibniz-Institut für die Pädagogik der Naturwissenschaften. <http://archiv.ipn.uni-kiel.de/stcse/> [25.06.2021].
- Garnett, P. J., & Treagust, D. F. (1992). Conceptual difficulties experienced by senior high school students of electrochemistry: Electric circuits and oxidation-reduction equations. *Journal of Research in Science Teaching*, 29(2), 121–142.
- Goes, L. F., Fernandez, C., & Eilks, I. (2020). The development of pedagogical content knowledge about teaching redox reactions in German chemistry teacher education. *Education Sciences*, 10(170).
- Karamustafaoglu, S., & Mamluk-Naaman, R. (2015). Understanding electrochemistry concepts using the POE strategy. *Eurasia Journal of Maths, Science and Technology Education*, 11(5), 923–936.
- KMK. (2020). *Bildungsstandards der Kultusministerkonferenz* [Educational standards of the Standing Conference of the Ministers of Education and Cultural Affairs]. Kultusministerkonferenz. <https://www.kmk.org/themen/qualitaetssicherung-in-schulen/bildungsstandards.html#c5034> [25.06.2021]
- Maichle, U. (1982). Schülervorstellungen zu Stromstärke und Spannung [Pupils' ideas about current and voltage]. *Naturwissenschaften im Unterricht. Physik/Chemie*, 30(11), 383–387.
- McDermott, L. C., & Shaffer, P. S. (1992). Research as a guide for curriculum development: An example from introductory electricity. Part I: Investigation of student understanding. *American Journal of Physics*, 60(11), 994–1013.
- Muckenfuß, H., & Walz, A. (1997). *Neue Wege im Elektrizitätsunterricht* [New ways of teaching electrics] (2<sup>nd</sup> rev. ed.). Aulis Deubner.
- Ogude, N. A., & Bradley, J. D. (1994). Ionic conduction and electrical neutrality in operating electrochemical cells: Pre-college and college student interpretations. *Journal of Chemical Education*, 71(1), 29–34.
- Pardhan, H., & Bano, Y. (2001). Science teachers' alternate conceptions about direct-currents. *International Journal of Science Education*, 23(3), 301–318. <https://doi.org/10.1080/095006901750066538>
- Psillos, D., Tiberghien, A., & Koumaras, P. (1988). Voltage presented as a primary concept in an introductory teaching sequence on DC circuits. *International Journal of Science Education*, 10(1), 29–43. <https://doi.org/10.1080/0950069880100104>
- Rhöneck, C. v. (1981). Schüleräußerungen zum Begriff der elektrischen Spannung beim Erklären der Meßwerte am Schalter [Pupils' comments on the concept of electrical voltage when explaining the measured values on the switch]. *Naturwissenschaften Im Unterricht. Physik/Chemie*, 29(6), 210–215.
- Rhöneck, C. v. (1986). Vorstellungen vom elektrischen Stromkreis und zu den Begriffen Strom, Spannung und Widerstand

- [Ideas about the electric circuit and the concepts of current, voltage and resistance]. *Naturwissenschaften Im Unterricht—Physik*, 34(13), 10–14.
- Rhöneck, C. v. (1988). Wege zum Spannungsbegriff [Ways to the concept of voltage]. *Naturwissenschaften Im Unterricht. Physik/Chemie*, 36(31), 4–11.
- Schmidt-Rohr, K. (2018). How batteries store and release energy: explaining basic electrochemistry. *Journal of Chemical Education*, 95, 1801–1810.
- Sesen, B. A., & Turhan, I. (2013). Inquiry-based laboratory activities in electrochemistry: High school students' achievements and attitudes. *Research in Science Education*, 43, 413–435.
- Shipstone, D. M. (1984). A study of children's understanding of electricity in simple D.C. circuits. *European Journal of Science Education*, 6(2), 185–198.
- Solomon, J., & Aikenhead, G. (Eds.). (1994). *STS education: International perspectives on reform*. Ways of knowing science series. Teachers College Press.
- Steinberg, M. S., & Wainwright, C. L. (1993). Using models to teach electricity—the CASTLE project. *The Physics Teacher*, 31(6), 35–357.
- Stockmayer, S. M., & Treagust, D. F. (1994). A historical analysis of electric currents in textbooks: A century of influence on physics education. *Science & Education*, 3(2), 131–154. <https://doi.org/10.1007/BF00486388>
- TüSE (2019). Der Leitfaden für Lehramtsstudierende [The guide for teaching students]. <https://uni-tuebingen.de/de/197827>.
- United Nations. (2015). *Paris Agreement*. [https://unfccc.int/sites/default/files/english\\_paris\\_agreement.pdf](https://unfccc.int/sites/default/files/english_paris_agreement.pdf) [25.06.2021].
- United Nations. (2021). *Education for Sustainable Development*. <https://en.unesco.org/themes/education-sustainable-development> [25.06.2021].
- Waltner, C., Späth, S., K., D., & Wiesner, H. (2009). Einführung von Stromstärke und Spannung—Ein Unterrichtskonzept und Ergebnisse einer Vergleichsstudie [Introduction of amperage and voltage—A teaching concept and results of a comparative study]. In D. Höttecke (Ed.), *Entwicklung naturwissenschaftlichen Denkens zwischen Phänomenen und Systematik: Jahrestagung der GDGP in Dresden 2009* (Vol. 30) (pp. 182–184). Lit-Verlag.

## Chapter 11

### Education for Sustainable Development as a Challenge for Teacher Education: Implementation at the University of Tübingen

Diana Grundmann, Matthias Bornemann and Thomas Potthast

*This chapter focuses on Education for Sustainable Development (ESD) and its implementation in the education of academic high school (Gymnasium) teachers at the University of Tübingen in Germany. First, an overview is provided of ESD's political context and its implementation in Germany's teacher education, particularly in the state of Baden-Württemberg, where Tübingen is located. Then, the results of the analysis of ESD implementation and related concepts in teacher education at the University of Tübingen are presented. This is based on two different methodological approaches: i) an analysis of module manuals and an online survey of teacher education staff representatives; ii) an analysis of an exemplary course (Seminar) at the University of Tübingen, in which students of the school subject Science and Technology (NwT) are brought into contact with ESD, with regard to the conceptual framework and results from surveys of the participants. In sum, the findings indicate that there are still many challenges that arise when implementing ESD in teacher education and that further effort is needed to overcome them. On the institutional level, ESD is still mainly present in the relevant topics of study in the natural sciences, and there, mainly in the bachelor's courses. At the same time, however, there are promising approaches to a broader implementation that need to be strengthened in social sciences, as well as in literary and language subjects. On the individual level, future teachers interested in ESD profit from the approach, but often struggle with putting the theoretical perspectives into practice and therefore need further support. The results of this chapter build a bridge to the chapter „Education for Sustainable Development (ESD) classroom practices: A South African perspective”. Looking at ESD also widens the scope of the book, since it is a cross-cutting theme beyond the canon of ‘classical’ school disciplines.*

<http://dx.doi.org/10.15496/publikation-76379>





## 1 Introduction

In 1987, the United Nation's World Commission on Environment and Development (WCED) coined the term “Sustainable Development” as a “development that meets the needs of the present without compromising the ability of future generations to meet their own needs. It contains within it two key concepts: the concept of ‘needs’, in particular the essential needs of the world's poor, to which overriding priority should be given; and the idea of limitations imposed by the state of technology and social organization on the environment's ability to meet present and future needs” (WCED, 1987, 41). To date, Sustainable Development has become increasingly important due to the worsening of environmental issues, like biodiversity loss and the climate crisis (IPBES, 2019, IPCC 2019), as well as socio-economic issues like poverty, malnutrition, and global ill health. In September 2015, the UN General Assembly adopted the 2030 Agenda for Sustainable Development, “a plan of action for people, planet and prosperity“ (UN, 2015, p. 3). The Sustainable Development Goals (SDGs) are at the core of the 2030 Agenda. SDGs describe the global challenges and, in 169 sub-goals, propose tangible steps towards Sustainable Development for the entire world. Their aim is “to secure a sustainable, peaceful, prosperous and equitable life on earth for everyone now and in the future” (UNESCO, 2017, p. 6).

Due to the importance of the problems at stake and the political significance of the SDGs in international, national, and regional governance, Sustainable Development has also become a major issue for education on every level. In this chapter, the focus lies on Education for Sustainable Development (ESD), which is a challenge for teacher education, more specifically for the education of high school teachers at a particular German university. First overviews are provided of the political and governance framework internationally, in Germany, and in Baden-Württemberg (section 2). Regarding the implementation at the University of Tübingen, results are presented of an analysis of module manuals (“Modulhandbücher”) and of an online survey of teacher education staff representatives regarding the implementation of ESD (section 3). This is complemented by a case study of ESD implementation in a specific curriculum for the school topic “Science and Technology” (“Naturwissenschaft und Technik”, NwT; chapter 4). Conclusions on the current state of ESD implementation for high school teachers at the University of Tübingen and further challenges are drawn in the final chapter (5).

## 2 Education for Sustainable Development (ESD) in teacher education

### 2.1 Sustainable Development (Goals) and ESD

Since the late 1980s, education has played a crucial role in the international discussion about Sustainable Development, as shown by *Agenda 21* (1992), the *UN-Decade for ESD* (2005–2014), the *Global Action Program on ESD* (2015–2019), the *SDGs* (2015) and the new framework *ESD for 2030* (2020–2030)<sup>1</sup>. Goal 4 of the SDGs promotes inclusive and equitable quality education for all. Thus, the SDGs are of special importance and interest for ESD and its implementation. Moreover, the SDGs stress the idea that ESD is an essential component of quality education (UNESCO, 2017). It must be ensured that by 2030, “all learners acquire the knowledge and skills needed to promote Sustainable Development, including, among others, through education for sustainable development”, as demanded in SDG 4.7 (UN 2015). ESD is an approach that encourages and promotes knowledge, skills, values, and attitudes that enable people to direct sustainable development (Leicht, Heiss & Byun, 2018; Rieckmann, 2019). But regardless of the direct link between ESD and the concept of Sustainable Development, the educational approach is not instrumental, but transformative, emancipatory, and competence-based (Rieckmann, 2018).

### 2.2 ESD and teacher education

In the international context (Leicht, Heiss & Byun, 2018) as well as in Germany (National Platform on Education for Sustainable Development, 2019), it is emphasized that ESD encompasses formal, non-formal and informal education. The implementation of ESD in schools is a major challenge and goal (UNESCO, 2014; National Platform on Education for Sustainable Development, 2019; KMK, DUK, 2007; Siege, Schreiber, 2016). Germany's National Action Plan on Education for Sustainable Development reads: “When it comes to successfully establishing Education for Sustainable Development (ESD) in the education system, school education is particularly important because of its formative influence on individual educational biographies” (National Platform on Education for Sustainable Development, 2019, p. 23). Teacher education is a prerequisite for achieving this goal and, accordingly, is demanded by UNESCO as the lead UN agency for ESD. This also holds for the national member states of the UN and signatories of the Agenda 2030, and

<sup>1</sup> The new framework „ESD for 2030“ was officially launched in May 2021. It was postponed due to the COVID-19 pandemic, the “Roadmap” being issued in Fall 2020 (UNESCO, 2020).

therefore also for Germany (UNESCO, 2014, p. 20; National Platform on Education for Sustainable Development, 2019; Qablan, 2018). In both the Global Action Program on ESD (2015–2019) and the global framework on ESD for 2030 (2020–2030), it is one of the five priority areas. The promotion of teachers' competencies for ESD involves two dimensions (Rieckmann, Holz, 2017, p. 6): teachers need to acquire sustainability competencies, and, moreover, specific teacher competencies for ESD that enable them to deal with issues of sustainable development in class, in a way that is appropriate in terms of content and didactics (Program Transfer-21, 2007, p. 9).<sup>2</sup> This entails, for example, the ability of teachers to help learners explore alternative possibilities for the future, or to help them act in situations of uncertainty (Scherak & Rieckmann, 2020).

### 2.3 Framework and state of implementation in Germany with a focus on Baden-Württemberg

The first phase of teacher training in Germany takes place at universities and colleges of education (Pädagogische Hochschulen; in some states, there is no more separation, but not in Baden-Württemberg). Thus, the topic “ESD in teacher education” is linked to the general discussion on ESD in higher education institutions (Bellina, Tegeler, Müller-Christ & Potthast, 2018; Rieckmann & Bormann, 2020). The German Rector's Conference has committed itself to the principle of Sustainable Development (HRK & DUK, 2009; HRK, 2018).

The following list provides an overview of important (educational) policy documents on ESD in Germany's teacher education:

- ▶ 2007: the KMK (Standing Conference of the Ministers of Education and Culture) and the DUK (German Commission for UNESCO) jointly published a recommendation on “Education for Sustainable Development at School”. The document addresses institutions for the training and continuing education of teachers. According to this recommendation, teachers should, during their initial training, acquire skills for covering Sustainable Development at school (KMK & DUK, 2007);
- ▶ 2007 and 2016: the KMK and the BMZ (German Federal Ministry of Economic Cooperation and Development) published the “Curriculum Framework Education for Sustainable Development”. The 2<sup>nd</sup> edition gives detailed information on

<sup>2</sup> For an overview of different concepts of sustainability competencies and concepts of competencies for ESD educators see Rieckmann (2018).

ESD in teacher education (requirements of ESD, steps of integration, examples). In the first phase, ESD needs to be integrated on the levels of subject systems (“Fachsystematiken”), subject-related didactics (“Fachdidaktiken”), and the educational science parts (“bildungswissenschaftliche Anteile”) of the study program (Overwien, 2016);

- ▶ 2008: the KMK published content-related requirements for subject systems and subject-related didactics in teacher education. Sustainable Development and/or ESD is explicitly reflected in the following subjects: Household and Nutrition; Technology; Textile; Economy; Biology, Chemistry; Geography (KMK, 2008);
- ▶ 2017: the National Action Plan on ESD is published by the BMBF (Federal Ministry of Education and Research). In this document, teacher and educational assistant training is described as a central action area for the integration of ESD at school. It states that “the Länder and teacher training institutions are committed to establishing ESD in initial and further training for teachers and will implement this on a Länder-specific basis according to their capabilities” (National Platform on Education for Sustainable Development, 2019, p. 30).

Baden-Württemberg is one of the 16 states that make up the Federal Republic of Germany, and the points listed above show important activities on the German federal level. Notwithstanding, it needs to be noted that school policy is, ultimately, a legislative and governance matter for the respective states. This leads to a somewhat heterogeneous landscape of school and teacher education in Germany. Since the University of Tübingen is located in Baden-Württemberg, the teacher training that takes place there relates directly to the requirements of the curricula relevant for this state. Hence the following steps and documents are important:

- ▶ 2007: Baden-Württemberg's sustainability strategy started in 2007. ESD has been anchored there as one central element. More specifically, the strategy states that ESD should be integrated in formal, non-formal and informal education. An integrated cross-departmental ESD strategy is currently being developed (UM BW, 2020).
- ▶ 2012: the university network on ESD in Baden-Württemberg (BNE-Hochschulnetzwerk)<sup>3</sup> was established in 2012. This network strengthens both the anchoring of ESD in the university context (focus: teacher training) and the networking of actors in ESD.

<sup>3</sup> <http://www.bne-hochschulnetzwerk.de>

- ▶ 2015: according to the legal framework for teacher education programs (“Rahmenvorgabenverordnung Lehramtsstudiengänge”) in Baden-Württemberg, ESD should be systematically implemented with the introduction of the new study programs for teachers (Bachelor and Master). The framework describes ESD as a cross-sectional competence of overriding importance, which therefore should be incorporated into the educational science part of all teacher education programs, as well as into the practical studies and the subject-related sciences and didactics.
- ▶ 2016: Baden-Württemberg's new formal curriculum was introduced, with six cross-curricular guiding perspectives. According to the curriculum, these guiding perspectives, including ESD, must be integrated into each school subject (see section 4 for an exemplary implementation).
- ▶ The principles of the so-called Beutelsbach Consensus explicitly apply to the new curriculum (Pant, 2016). Originally developed in the context of political education during the Cold War, the “Beutelsbach Consensus” declares the prohibition of indoctrinating school students with political and world views (“Überwältigungsverbot”), the imperative to present controversial standpoints, and the consideration of student interests. This underlines both the understanding and the task of ESD as a non-instrumental approach (see above and Pottthast, 2019).

Regarding the integration of ESD in Baden-Württemberg's teacher education, the following should be noted: in 2014, before the new legal framework for teacher education programs and the new curriculum came into force, a study on the integration of ESD in Baden-Württemberg's teacher education was conducted. It turned out that in 2014, there was hardly any evidence of a structural anchoring of ESD in the study regulations (Mrazek & Siegmund, 2016). Three years later, in 2017, at half-time of the Global Action Program on ESD (2015–2019), the Conference of the Ministers of Education (Kultusministerkonferenz, KMK)<sup>4</sup> published a report on the situation and perspectives of ESD in Germany. It was based on information provided by the federal states themselves. For Baden-Württemberg, it was reported that a comprehensive integration of ESD in teacher education for all subjects is ensured via the framework regulations (KMK, 2017, p. 53).

<sup>4</sup> „The Standing Conference of the Ministers of Education and Cultural Affairs” is the oldest conference of ministers in Germany and plays a significant role as an instrument for the coordination and development of education in the country. It is a consortium of ministers responsible for education and schooling, institutes of higher education and research and cultural affairs, and in this capacity formulates the joint interests and objectives of all 16 federal states; <https://www.kmk.org/kmk/information-in-english.html>.

However, the academic monitoring of the Global Action Program shows that this is not entirely successful, although in Baden-Württemberg, the integration of ESD into teacher education seems to be more effective than in other federal states (Brock, 2018; Holst & Brock, 2020; Holst et al., 2020). Within the scope of the monitoring study, examination regulations and course handbooks from 15 higher education institutions in five federal states (Baden-Württemberg, Berlin, Lower Saxony, North Rhine-Westphalia, Saxony) were analyzed.<sup>5</sup> The monitoring reveals a high discrepancy between the “structural implementation of ESD in curricula and its integration into teacher training. While no or very few references to ESD and related concepts were found within the documents from Lower Saxony, North Rhine-Westphalia, and Saxony, some subject-specific matches were found for Berlin and Baden-Wuerttemberg” (Holst et al., 2020, p. 8).

### 3 Empirical findings on ESD in teacher education at the University of Tübingen

To gain an overview of ESD implementation in teacher education at the University of Tübingen, two empirical surveys with different methodical approaches were conducted: a qualitative analysis of the module manuals for teacher education and an online survey of teaching staff within the University of Tübingen. The first approach shows the extent to which ESD is anchored in the various degree programs of teacher education. The second supplements this with an actor-related perspective and provides insights into the practical implementation of the curricular requirements. The combination of methodological approaches was chosen to get a multifaceted first picture. It should be noted that due to resource limitations, the studies are more exploratory than encompassing. Nevertheless, they allow for important insights.

#### 3.1 Analysis of module manuals

The approach of the document analysis is based on classical procedures of educational monitoring. It was a central element in the German Monitoring of the Global Action Program on ESD (Brock, 2018; Holst et al., 2020). In accordance with this national approach, a total of 50 module manuals of the teacher education program at the University of Tübingen were analyzed. The study encompasses all 24 degree pro-

<sup>5</sup> The three universities with the largest number of teaching graduates in Baden-Württemberg: PH Freiburg, PH Heidelberg, PH Ludwigsburg.

grams that can be studied as a first or second major for the Bachelor and Master of Education.<sup>6</sup> In addition, the Educational Science Studies (“Bildungswissenschaftliches Studium”), which are compulsory for all teacher training students, were taken into consideration (Bachelor and Master). The analysis of module manuals consisted of four steps: 1. lexical content analysis, 2. differentiated analysis of the general qualification goals of all degree programs, 3. differentiated analysis of all course modules (without didactics) and 4. analyses of all the didactic modules. These steps are described below.

In the first step, a lexical content analysis of relevant terms was performed using MAXQDA. The keywords were selected in accordance with the methodological approach of the Global Action Program's monitoring on ESD. These are (translated from German):

- ▶ Education for Sustainable Development, ESD, shaping competency (“Gestaltungskompetenz”)
- ▶ Sustainable Development, Sustainability, Sustainable, Sustain (in German and English)
- ▶ Environmental Education/Pedagogy, Nature Education/Pedagogy, Ecological Education, Global Learning, Learning in Global Contexts, Global Development, Development Policy Education, Intercultural Education/Learning.

The lexical content analysis shows 25 matches relevant to the normative concept of SD in 10 (of 50) study degree programs. Without differentiating between the bachelor's and master's, these matches are found in Science and Technology (10), Geography (4), Chemistry (3), Economics (3), Educational Science Studies (3) and Biology (2). The results are shown in table 1.

Alternative suffixes were included in the analysis. The table contains only subjects and keywords with matches. In cases where the terms are used in other connotations (e.g., “sustainable” in the sense of long-lasting) the matches are shown in brackets.

---

<sup>6</sup> Biology, Catholic Theology, Chemistry, Chinese, Computer Science, Economics, English, French, Geography, German, Greek, History, Islamic Religious Education, Italian, Latin, Mathematics, Philosophy/Ethics, Physical Education, Physics, Political Science, Protestant Theology, Russian, Science and Technology, Spanish.

		Sustainable	Sustainability	Education for Sustainable Development	Sustainable Development	Total
<b>Biology</b>	B.Ed.		1			1
	M.Ed.		1			1
<b>Chemistry</b>	B.Ed.		2			2
	M.Ed.		1			1
<b>Economics</b>	B.Ed.		3			3
<b>Educational Science Studies</b>	B.Ed.		1			1
	M.Ed.			2		2
<b>Geography</b>	B.Ed.	1		2		3
	M.Ed.			1		1
<b>Political Science</b>	M.Ed.	(1)				(1)
<b>Science and Technology</b>	B.Ed.		7		3	10
	M.Ed.	(1)				(1)
<b>Total</b>		1 (+2)	16	5	3	25 (+2)

*Table 1 Results of the lexical analysis*

These findings indicate three systematic insights. Firstly, Sustainable Development and ESD are only anchored in a minority of degree programs (10 of 50). Secondly, this mainly concerns degree programs that are closely related to Sustainable Development (i.e., Biology and Geography). Thirdly, it is noticeable that the concept of ESD appears increasingly, or in some cases even exclusively, in the bachelor's degree programs.

In the second step, a differentiated analysis was carried out regarding the sections in the module manuals where the general qualification goals (competencies and learning outcomes) of the respective degree programs are established. In addition to the lexical analysis, it was also examined whether the normative concept of SD is implicitly reflected in the qualification goals. This analysis shows matches of explicit / implicit SD use or the integration of key aspects in 18 (of 50) study programs. The results are shown in table 2.



<b>Explicit use of the terms Sustainability / Sustainable Development / ESD (Total: 5)</b>	Biology (B.Ed., M.Ed.)	
	Chemistry (B.Ed., M.Ed.)	
	Educational Science Studies (M.Ed.)	
<b>Implicit use of the concept of Sustainable Development (Total: 2)</b>	Geography (B.Ed., M.Ed.)	human-environment interactions; linking of ecological, economic, and social perspectives
<b>Key aspects of Sustainable Development are included (Total: 11)</b>	Computer Science (B.Ed., M.Ed.)	reflection on social impacts in the context of information technology
	Economics (B.Ed. / M.Ed.)	business ethics questions in economic education
	Educational Science Studies (B.Ed.)	social change processes and their relation to the teaching profession
	History (B.Ed., M.Ed.)	transformation processes in history
	Philosophy / Ethics (B.Ed., M.Ed.)	the ethical dimension of life-world topics / social issues
	Physics (M.Ed.)	the evaluation of social issues from a physical perspective
	Science and Technology (M.Ed.)	integration of perspectives from nature, society, natural sciences, and technology
	All language study programs and the theological subjects	interculturality, heterogeneity, diversity

*Table 2 SD/ESD in the general qualification goals*

These results show that it is worth going beyond the lexical content analyses. Sustainability, Sustainable Development and/or ESD are mentioned explicitly in the qualification goals of 5 study programs and implicitly in 2 other programs. But by broadening one's perspective, one can see that, on the level of the qualification goals' key aspects, Sustainability can be found in an additional 11 degree programs. Compared to the previous lexical content analysis (table 1, matches in 10 of 50 programs), this analysis of qualification goals shows ESD topics and connecting points in a total of 18 degree programs, including Philosophy / Ethics, Computer Science, and History.

In the third step, the implementation of Sustainable Development in the modules

(without didactics) was examined. As Table 3 shows, different groups could also be distinguished here.

<b>Sustainability / Sustainable Development / ESD in module titles</b>	Science and Technology (B.Ed.)	Energy, Environment and Sustainability
<b>Sustainability / Sustainable Development / ESD in module descriptions</b>	Geography (B.Ed.)	Regional Geography of Germany / Southern Germany
	Economics (B.Ed.)	Introduction to Business Administration Ethical principles
	Chemistry (B.Ed.)	General and Inorganic Chemistry for student teachers 1
	Educational Science Studies (B.Ed.)	Educational Science Studies 1
	Educational Science Studies (M.Ed.)	In-depth module
<b>Highly relevant modules (without using the term explicitly)</b>	Biology (B.Ed.)	Ecology and Biodiversity 1
	Biology (M.Ed.)	Ecology and Biodiversity 2
	Geography (B.Ed.)	Geo-ecology Climate and hydrogeography
	Geography (M.Ed.)	People and environment

Table 3 SD/ESD in the modules (without didactics)

A total of 12 sustainability modules in 10 different study programs (out of 50) were found. In addition, 31 modules in 15 study programs were identified that, in principle, offer immediate opportunities to integrate the perspective of sustainability. These 31 modules are listed in table 4.<sup>7</sup>

<b>Module</b>	<b>Link to sustainability topic</b>
Catholic Theology (B.Ed.)	Responsibility in Culture and Society
Catholic Theology (M.Ed.)	Systematic Theology and Theological Ethics
Chinese (B.Ed.)	Extension Module Sinology / Chinese Studies
Economic Sciences (B.Ed.)	Economic Education Political Science

<sup>7</sup> It should be noted that ESD elements can also be integrated in subjects not listed here, and allegedly unrelated to SD; for example, in mathematics, the importance of understanding how to deal with statistics regarding climate change. See also for further potential in (E)SD below.

English (B.Ed.)	Basic Module Cultural Studies Literary and Cultural Studies Advanced Module Literary Studies
English (M.Ed.)	Literary and Cultural Studies
Geography (B.Ed.)	Economic Geography Basics of Human Geography Population and Social Geography
History (B.Ed.)	Deepening and Specialization: History of the Modern Era
Islamic Theology (B.Ed.)	Islamic Religious Education I Theoretical Approaches to Religion Islam and Society Islamic Religious Education II
Islamic Theology (M.Ed.)	Religion and Society Theoretical Approaches to Religion
Philosophy (B.Ed.)	Basic Module Practical Philosophy Basic Module Interdisciplinary Issues Advanced Module Practical Philosophy Advanced Module Interdisciplinary Issues
Philosophy (M.Ed.)	Advanced Module Interdisciplinary Issues Advanced Module Practical Philosophy
Politics (B.Ed.)	Policy Fields Political Theory International Relations
Politics (M.Ed.)	European Politics and International Relations Peace and Conflict Studies
Sports (M.Ed.)	Interdisciplinary Contexts

*Table 4 Modules with links to sustainability topics*

In the last step of the manual analyses, the didactic modules of all subjects were screened. Here, references to Sustainable Development were only found in geography, where ESD is explicitly addressed in both the master's and bachelor's programs. In addition, ESD plays an important role in "Science and Technology" (Course: Understanding and Teaching Sustainable Development). However, this course is not located in didactics. This shows that the topics of sustainable development and ESD have so far been given little consideration in the didactic training of teaching students.

### 3.2 Online survey of teacher training staff representatives

The online questionnaire was accessible to the invited respondents for a total of three weeks (from 20<sup>th</sup> August until 14<sup>th</sup> September 2020) on the Sosci-Survey platform. The interviewees were contact persons for the individual teacher education courses in different subjects at the University of Tübingen. A total of 21 data sets were collected, 16 of which could be used for evaluation. For the bachelor's and master's programs, 10 questions each were collected, 5 of them open and 5 closed questions. The closed questions also included a ranking question on the topic of students' interests in SD.

To summarize the results, we can distinguish three categories of ESD integration in the teaching subjects, namely established ESD, potential for ESD, and negated ESD.

1. **Established ESD:** there are subjects that already offer modules and courses on ESD. It can be clearly seen that ESD is still understood with a strong reference to environmental topics, which is why integration in subjects such as biology and Science and Technology (NwT) is pronounced. Consequently, sustainability issues such as the adequate handling of natural resources and biodiversity show the importance of ESD. This is also evident in sports, where a strong connection is made with questions of sport and nature, and with other topics, such as nutrition and the sustainability of big sport events or sportswear (e.g., environmental impact of different sports, production conditions for workers in the sports industry). At the same time, there are also ESD modules in the study programs of Islamic Theology and Economics. There, the view is widened, going beyond environmental references to topics like maturity and sustainable management.
2. **Potential ESD:** the second category consists of subjects that have no explicit ESD offerings, but where this topic could, in principle, have been included. Many teacher-training courses in language and literary studies (French, Italian, Spanish, English, German) do not currently offer ESD, but many of the participants in the survey do see opportunities and points of contact. Several references have been made to the possibility of dealing with the literature of so-called ecocriticism (humankind's place in nature, environmental issues etc.) and the reinterpretation of classical literature regarding current questions of Sustainable Development.
3. **Negated ESD:** some teacher education program representatives firmly reject the need to integrate perspectives on ESD and see no need for this topic. For example, it is argued that astronomy is a subject that deals with the cosmos, not the earth.

It should also be mentioned that in the given responses, there are no significant differences within the subjects between bachelor's and master's programs. The answers from the participants responsible for both types of courses are mostly identical. Another remarkable point is the students' interest in ESD issues, as perceived by the survey participants. This was rated as very high in both category 1 and category 2 answers. Only the answers from category 3 gave few or no points or left the question unanswered. The possible consequences for curriculum design, however, have not been dealt with in the answers.

#### 4 Example of implementation at the University of Tübingen

In this section, an exemplary course (“Seminar”) that introduces elements of ESD into teacher education will be presented. In the context of this seminar, questionnaires were distributed among the students over two semesters. The results of these questionnaires suggest that the students have difficulties in transferring the theoretical perspectives of ESD into the practical implementation of teaching.

Science and Technology (NwT = **N**atur**w**issenschaft und **T**echnik) is a school subject which, besides the federal state of Saxony, is only taught in this form in Baden-Württemberg and was first implemented in 2007. The subject is designed for higher grades (mainly grades 7–10) and is therefore taught in secondary schools. The special conception of the subject comes with the idea of a connected thinking and of observing issues in an interrelated way. This means that the subject follows the idea of interdisciplinarity and therefore does not replace the linked subjects, e.g., biology, chemistry, and geography. The aim of NwT is to connect the knowledge the students have acquired in the natural sciences and to focus more on practical technological aspects and the everyday reality of the students (MKJS, 2015).

The NwT courses are oriented to different so-called central guiding perspectives (“Leitperspektiven”), which were introduced with the renewal of the school curricula. One of these principles is Education for Sustainable Development. By focusing on the needs and resources of current and future generations, it follows the Brundtland-Report understanding (WCED, 1987). Concerning the NwT curricula, the general idea is to transmit the relations of nature, technology, and society (MKJS, 2015, p. 4). Consequently, the structure of the teaching subject also determines the basic pillars (interdisciplinarity and practical orientation) of the NwT course. And because of the importance of ESD in the subject, seminars on this topic are also needed in the training of teachers for the teaching of NwT. This is where a seminar conducted by the

authors of this text is situated. “Nachhaltige Entwicklung verstehen, gestalten und unterrichten” (Understanding, Shaping and Teaching Sustainable Development) is a course within the Bachelor of Education for NwT. It was first developed within the University of Tübingen’s Competence Center for Sustainable Development. In a second step, it was connected to approaches and topics of the transdisciplinary research project “Energy Laboratory Tübingen” (see Albiez et al., 2018) and further adopted throughout the years in accordance with the students’ feedback. It was the topic of sustainable energy systems (see also SDG 7 “Affordable and clean energy”) that enabled the perspective of ESD to be integrated in the NwT module. The teaching staff was initially a co-teaching team from physics and pedagogy, later also in combinations of one person from natural science and another from social/ educational science.

The course is composed of two parts. In the first half of sessions (each unit 90 minutes), the participants get to know the theoretical background not only of ESD, but also of ESD teaching methods, the idea of transdisciplinarity, and the creation of a draft lesson plan (“Unterrichtsentwurf”). The view becomes more and more focused, so that from a very broad input on SD, the participants get to know several knowledge components and didactic tools, allowing them to shape their own teaching. They do so by preparing a lesson unit(s) plan on a course topic of their own choice, also selecting the student’s level (years 7–10). This draft is presented to the other participants at the beginning of each session in the second part of the course. The presenting group has time to practise a certain part of their lesson idea with the other participants, who simulate a school class. Afterwards, the presentation group receives feedback on their conceptual draft, their presentation of it, and their simulation of a lesson from the other participants as well as from the lecturers. The feedback focuses on certain criteria, such as: does the draft fit the target group (e.g., is it adapted to the grade level)? How are the relations to (E)SD presented? Is the planned draft feasible on a practical level, e.g., in terms of time and materials?

In two courses (winter terms 2018/19 and 2019/20), the participants (each term 21 students = 42 in sum) were asked to fill out an additional feedback form on a voluntary basis. Besides the generic and more formal evaluation sheets for courses by the university itself, the former focused on questions concerning the general conception of the course. The students had the possibility of answering the following open questions:

- ▶ What did you like about the seminar? What did you take home?
- ▶ What did you not like about the seminar? What was missing?
- ▶ What suggestions for improvement do you have for the seminar and the lecturers?

In the winter term 2018/19, we received 8 questionnaires, and 15 in the winter term 2019/20 (n=23). As they were open questions, the responses are, of course, quite diverse. However, there are some common threads in the questionnaires. The participants had positive views on the course in general and especially on the opportunity to create their own draft lesson plan, which is quite rare throughout their studies. They saw it as a chance to try something new. Several participants profited from and appreciated the setting (“*particularly good: working out lesson plans with feedback → first (and probably only) time in the degree course where you really get an insight into practical teacher work*”; “*we were allowed to experience, plan, and also carry out a teaching unit independently. This develops ideas/new perspectives for later careers*”)<sup>8</sup> and the open discussions (“*Many discussions → have been thought-provoking*”). Others saw them as distracting and sought for more natural science input (“*Most of us are not versed in philosophical and ethical theory. It would have made more sense (would have taken me further) if the conclusions about sustainability had been drawn more from scientific methods and facts and less from ethical theory*”).<sup>9</sup> Furthermore, most of the participants had the impression that the theoretical part did not directly prepare them for creating the lesson plan. This impression was shared by the lecturers: although the lesson plans were quite well prepared, hardly one of them was based on the theoretical input on ESD provided in the first part of the course. Especially when it comes to more nuanced aspects of SD, the presentation groups often neglected to integrate them. Yet this rather sobering impression should be viewed in its context: students of NwT are already located in a demanding interdisciplinary setting, between science and technology and its practical implementation. To successfully integrate ESD into this study context in and by just one course is an ambitious aim, both for students and for teachers not familiar with SD and ESD. At the same time, it is the opening of broader reflective perspectives by both SD and ESD that enables us to take another step towards SDG 4.

## 5 Conclusions

Although high on the political and educational agendas, and well-equipped with elaborate theories as well as practical suggestions (sections 1 and 2), the implementation of ESD is still a desideratum in large swathes of teacher education. This holds for

---

<sup>8</sup> All translations from the student quotes in German by the authors.

<sup>9</sup> The issue of inferring ethical or political consequences mainly from alleged ‘scientific’ facts, is a critical one for science education and indicates a lack of proper epistemological and ethical training.

Germany and, more specifically, for the state of Baden-Württemberg and the University of Tübingen<sup>10</sup>. This finding also matches the situation in South Africa, as described in the chapter by Mandikonza and Kawai (2022; this volume).

As our analysis of module handbooks and the online survey show, ESD is still mainly located—and thriving—in ‘classical’ subjects like geography and biology, where the relation to environmental education is direct and established (section 3). The analysis of the module handbooks revealed the inclusion of sustainability and/or ESD in about one fifth of the study programs. At the same time, promising potentials are visible in science and technology subjects, social sciences, and in literary and language subjects. Fostering these and implementing them more fully in the respective curricula shall be the next steps.

As the case example of a Science and Technology course showed, integrating ESD by means of just one course appears too high an expectation for both students and teachers (section 4). Explicit integration of ESD in more courses needs to be set in practice, which is in accord with the overall strategies for implementing ESD as a cross-cutting perspective (rather than only by one topical course). A first step may be emphasizing the links between ESD and environmental education, as Mandikonza and Kawai (2022; this volume) suggest. However, we strongly argue for not restricting Sustainable Development to environmental questions (cf. Albiez et al., 2018; Bellina et al., 2020).

Although, for reasons of limited resources, we could not investigate the didactics of ESD, we want to stress that ESD didactics training of students as well as university teachers is generally an issue and deserves special attention. In didactics of teacher education in general, ESD plays a rather subordinate role. ESD requires teaching students to reflect on the normative concept of Sustainable Development, to acquire solid knowledge on sustainability issues in their own subject, and to develop pedagogical competencies for implementing this transformative, emancipatory, and competency-based educational approach (Bellina et al. 2020). Again, the challenge of normativity is also noted in the South African context (Mandikonza & Kawai, 2022; this volume), and the following question remains open: how exactly can and should normativity be dealt with, especially by students not acquainted with academic philosophical or ethical reasoning?

In general, the challenge remains to teach ESD by integrating environmental and technical, as well as social and cultural perspectives. It calls for an attempt to integrate ESD in several—ideally all—courses throughout the curriculum. This also follows

---

<sup>10</sup> It may be noted that the situation in Tübingen, compared to other universities in this state, is rather advanced, despite being beyond 50% implementation in the modules investigated.



the folk wisdom that repetition—or to be exact, variation of the same motif—shall bring about success in education. In addition, explicit integration of ESD into the didactics courses is desired. Advanced peer-to-peer and cross-disciplinary ESD training for teaching staff are therefore required to ensure successful and broad implementation.

## Acknowledgements

We would like to thank the (anonymous) reviewers for their constructive and helpful remarks. Our gratitude goes to our colleagues from the Physics Department: Peter Grabmayr, for actively bringing ESD into the NwT curriculum and participating in the first courses, and Johannes Bleibel for his ongoing support. Marius Albiez and Andri König from the International Center for Ethics in the Sciences and Humanities (IZEW) have been co-teaching three runs. Last but by far not least, Jasmin Goldhausen and Luisa Böhm provided support in the survey activities, which proved to be extremely valuable.

## Literature

- Albiez, M., König, A., & Potthast, T. (2018). Transdisziplinarität und Bildung für Nachhaltige Entwicklung in der Lehre an der Universität Tübingen: Konzeptionelle Fragen mit Bezug auf Lehraktivitäten des „EnergieLABs Tübingen“ [Transdisciplinarity and education for sustainable development in teaching at the University of Tübingen: Conceptual questions with reference to teaching activities of the „Energy Laboratory Tübingen“]. In W. L. Filho (Ed.), *Nachhaltigkeit in der Lehre. Eine Herausforderung für Hochschulen. Theorie und Praxis der Nachhaltigkeit* (pp. 189–206). Springer. [https://link.springer.com/chapter/10.1007/978-3-662-56386-1\\_12](https://link.springer.com/chapter/10.1007/978-3-662-56386-1_12).
- Bellina, L., Tegeler, M.K., Müller-Christ, G., & Potthast, T. (2018). Bildung für Nachhaltige Entwicklung (BNE) in der Hochschullehre (Betaversion). BMBF-Projekt „Nachhaltigkeit an Hochschulen: entwickeln—vernetzen—berichten (HOCHN)“ [Education for sustainable development (ESD) in higher education (2<sup>nd</sup> ed.). BMBF project “Sustainability at universities: develop—network—report (HOCHN)”. <https://www.hochn.uni-hamburg.de/-downloads/handlungsfelder/lehre/hoch-n-leitfaden-bne-in-der-hochschullehre.pdf>.
- Brock, A. (2018). Verankerung von Bildung für nachhaltige Entwicklung im Bildungsbereich Schule [Anchoring education for sustainable development in the school education sector]. In A. Brock, G. de Haan, N. Etzkorn & M. Singer-Brodowski (Eds.), *Wegmarken zur Transformation. Nationales Monitoring von Bildung für nachhaltige Entwicklung in Deutschland* (pp. 67–116). Barbara Budrich.
- Hochschulrektorenkonferenz (HRK). (2018). *Empfehlung der 25. Mitgliederversammlung der HRK am 06. November 2018 in Lüneburg. Für eine Kultur der Nachhaltigkeit* [Recommendation of the 25<sup>th</sup> General Assembly of the HRK on 6. November 2018 in Lüneburg. For a culture of sustainability]. [https://www.hrk.de/fileadmin/redaktion/hrk/02-Dokumente/02-01-Beschluesse/HRK\\_MV\\_Empfehlung\\_Nachhaltigkeit\\_06112018.pdf](https://www.hrk.de/fileadmin/redaktion/hrk/02-Dokumente/02-01-Beschluesse/HRK_MV_Empfehlung_Nachhaltigkeit_06112018.pdf).
- Hochschulrektorenkonferenz (HRK), Deutsche UNESCO-Kommission (DUK). (2009). *Hochschulen für nachhaltige Entwicklung. Erklärung der Hochschulrektorenkonferenz (HRK) und der Deutschen UNESCO-Kommission (DUK) zur Hochschulbildung für nachhaltige Entwicklung* [Higher education for sustainable development. Declaration of the German rectors' conference (HRK) and the German commission for UNESCO (DUK) on higher education for sustainable development]. [https://www.hrk.de/fileadmin/\\_migrated/content\\_uploads/Hochschulen\\_und\\_Nachhaltigkeit\\_HRK\\_DUK.pdf](https://www.hrk.de/fileadmin/_migrated/content_uploads/Hochschulen_und_Nachhaltigkeit_HRK_DUK.pdf).

Holst, J., & Brock, A. (2020). *Bildung für nachhaltige Entwicklung (BNE) in der Schule. Strukturelle Verankerung in Schulgesetzen, Lehrplänen und der Lehrerbildung: Kurzbericht zu Beginn des UNESCO BNE-Programms „ESD for 2030“* [Education for sustainable development (ESD) in schools. Structural anchoring in school laws, curricula and teacher education: Short report at the start of the UNESCO BNE-program “ESD for 2030”].

Holst, J., Brock, A., Singer-Brodowski, M., & de Haan, G. (2020). Monitoring progress of change: Implementation of education for sustainable development (ESD) within documents of the German education system. *Sustainability*, 12(10), 1–19.

IPBES—Intergovernmental science-policy platform on biodiversity and ecosystem services (2019): *Global assessment report on biodiversity and ecosystem services*. <https://www.ipbes.net/global-assessment-report-biodiversity-ecosystem-services>

IPCC—Intergovernmental Panel on Climate Change (2018). *Special report: Global warming of 1.5 °C*. <https://www.ipcc.ch/sr15/>

Kultusministerkonferenz (KMK). (2008). *Ländergemeinsame inhaltliche Anforderungen für die Fachwissenschaften und Fachdidaktiken in der Lehrerbildung: (Beschluss der Kultusministerkonferenz vom 16.10.2008 i. d. F. vom 16.05.2019)* [Common content requirements for the sciences/humanities and didactics in teacher education: (Decision of the conference of education ministers on 16.10.2008, as amended on 16.05.2019)]. [https://www.kmk.org/fileadmin/Dateien/veroeffentlichungen\\_beschluesse/2008/2008\\_10\\_16-Fachprofile-Lehrerbildung.pdf](https://www.kmk.org/fileadmin/Dateien/veroeffentlichungen_beschluesse/2008/2008_10_16-Fachprofile-Lehrerbildung.pdf)

Kultusministerkonferenz (KMK). (2017). *Zur Situation und zu Perspektiven der Bildung für nachhaltige Entwicklung: Bericht der Kultusministerkonferenz vom 17.03.2017* [On the situation and perspectives of education for sustainable development: Report of the conference of education ministers on 17.03.2017]. [https://www.kmk.org/fileadmin/Dateien/veroeffentlichungen\\_beschluesse/2017/2017\\_03\\_17-Bericht-BNE-2017.pdf](https://www.kmk.org/fileadmin/Dateien/veroeffentlichungen_beschluesse/2017/2017_03_17-Bericht-BNE-2017.pdf)

Kultusministerkonferenz (KMK) und Deutsche UNESCO-Kommission (DUK). (2007). *Empfehlung der Ständigen Konferenz der Kultusminister der Länder in der Bundesrepublik Deutschland (KMK) und der Deutschen UNESCO-Kommission (DUK) vom 15.06.2007 zur „Bildung für nachhaltige Entwicklung in der Schule“* [Recommendation of the Standing Conference of the Ministers of Education and Cultural Affairs of the states in the Federal Republic of Germany (KMK) and the 15/06/2007 German commission for UNESCO (DUK) on “education for sustainable development in schools“]. [http://nachhaltigkeit.bildung-rp.de/fileadmin/user\\_upload/nachhaltigkeit.bildung-rp.de/Downloads/070615\\_KMK-DUK-Empfehlung\\_BNE.pdf](http://nachhaltigkeit.bildung-rp.de/fileadmin/user_upload/nachhaltigkeit.bildung-rp.de/Downloads/070615_KMK-DUK-Empfehlung_BNE.pdf)

Leicht, A., Heiss, J., & Byun, W. J. (Eds.) (2018). *Education on the move. Issues and trends in education for sustainable development*. UNESCO. [https://en.unesco.org/sites/default/files/issues\\_o.pdf](https://en.unesco.org/sites/default/files/issues_o.pdf)

Mandikonza, C. & Kavai, P. (submitted for publication). Education for Sustainable Development (ESD) Classroom Practices: A South African Perspective. In E. Hofmann, E. Mavhunga, T. Bohl, F. Maringe, D. Diekmann (Eds.) (2023). *Teacher Education in South Africa and Germany. Shared perspectives on national and global questions*. Tübingen University Press.

MKJS—Ministerium für Kultus, Jugend und Sport Baden-Württemberg (2015). *Rahmenvorgabenverordnung Lehramtsstudiengänge—RahmenVO-KM* [Framework ordinance on teacher education programs—FrameworkVO-KM]. <http://www.landesrecht-bw.de/jportal/?quelle=jlink&docid=jlr-LehrRahmenVBWrahmen&psml=bsbawueprod.psm1&max=true>

MKJS—Ministerium für Kultus, Jugend und Sport Baden-Württemberg (2016). *Naturwissenschaft und Technik (NwT)—Profilsfach* [Science and technology (NwT)—Profile subject]. *Bildungsplan des Gymnasiums*, 3(38), 1–44.

Mrazek, J., & Siegmund, A. (2016). *Bildung für nachhaltige Entwicklung (BNE) im Lehramtsstudium in Baden-Württemberg* [Education for sustainable development (ESD) in the teacher education program in Baden-Württemberg]. *Lehren & Lernen. Zeitschrift für Schule und Innovation aus Baden-Württemberg*, 42(8/9), 39–42.

National Platform on Education for Sustainable Development c/o Federal Ministry of Education and Research (2019). *National action plan on Education for Sustainable Development: The German contribution to the UNESCO global action program*. [https://www.bne-portal.de/bne/shareddocs/downloads/files/bmbf\\_nap\\_bne\\_en\\_screen\\_2.pdf?\\_\\_blob=publicationFile](https://www.bne-portal.de/bne/shareddocs/downloads/files/bmbf_nap_bne_en_screen_2.pdf?__blob=publicationFile)

Overwien, B. (2016). Education for global and sustainable development in teacher education. In H. Siege & J. R. Schreiber (eds.), *Education for sustainable development: Curriculum framework: a contribution to the global action program education for sustainable development* (2<sup>nd</sup> updated and extended edition, pp. 420–435). Cornelsen.

Pant, H. A. (2016). *Einführung in den Bildungsplan 2016* [Introduction to the 2016 education plan]. <http://www.bildungsplaene-bw.de/Lde/LS/BP2016BW/ALLG/EINFUEHRUNG>.

Pothast, T. (2019). *Berufsethos für Lehrerinnen und Lehrer, Ethik in den Wissenschaften und die Frage der Werte-Orientierung—kritische Überlegungen* [Professional ethics for teachers, ethics in the sciences and the question of value orientation

- critical reflections]. In C. Cramer, M. Drahmman & F. Oser (Eds.), *Ethos: Interdisziplinäre Perspektiven auf den Lehrerinnen- und Lehrerberuf*. In Memoriam Martin Drahmman (pp. 143–151). Waxmann.
- Programm Transfer-21. (2007). *Bildung für nachhaltige Entwicklung in der Lehrerbildung—Kompetenzerwerb für zukunftsorientiertes Lehren und Lernen* [Education for Sustainable Development in teacher education—acquiring competencies for future-oriented teaching and learning]. [http://www.transfer-21.de/daten/lehrerbildung/AGL\\_Strategiepapier.pdf](http://www.transfer-21.de/daten/lehrerbildung/AGL_Strategiepapier.pdf).
- Qablan, A. (2018). Building capacities of educators and trainers. In A. Leicht, J. Heiss & W. J. Byun (Eds.), *Education on the move. Issues and trends in education for sustainable development* (pp. 133–156). UNESCO. [https://en.unesco.org/sites/default/files/issues\\_o.pdf](https://en.unesco.org/sites/default/files/issues_o.pdf)
- Rieckmann, M. (2018). Learning to transform the world: Key competencies in Education for Sustainable Development. In A. Leicht, J. Heiss & W. J. Byun (Eds.), *Education on the move. Issues and trends in education for sustainable development* (pp. 39–59). UNESCO. [https://en.unesco.org/sites/default/files/issues\\_o.pdf](https://en.unesco.org/sites/default/files/issues_o.pdf)
- Rieckmann, M. (2019). Beiträge einer Bildung für nachhaltige Entwicklung zum Erreichen der Sustainable Development Goals—Perspektiven, Lernziele und ForschungsB.Ed.arfe [Contributions of education for sustainable development to achieving the Sustainable Development Goals—perspectives, learning objectives, and research needs]. In I. Clemens, S. Hornberg & M. Rieckmann (Eds.), *Bildung und Erziehung im Kontext globaler Transformationen* (pp. 79–94). Barbara Budrich.
- Rieckmann, M., & Holz, V. (2017). Verankerung von Bildung für nachhaltige Entwicklung in der Lehrerbildung in Deutschland [Anchoring education for sustainable development in teacher education in Germany]. *ZEP: Zeitschrift für internationale Bildungsforschung und Entwicklungspädagogik*, 40(3), 4–10.
- Rieckmann, M., & Bormann, I. (2020). *Higher education institutions and sustainable development: implementing a whole-institution approach*. Printed Edition of the Special Issue Published in Sustainability. Basel. <https://doi.org/10.3390/books978-3-03936-989-8>
- Scherak, L., & Rieckmann, M. (2020). Developing ESD competences in higher education institutions—staff training at the University of Vechta. *Sustainability*, 12(24), 10336. <https://doi.org/10.3390/su122410336>
- Schopp, K., Bornemann, M., & Potthast, T. (2020). The whole-institution approach at the University of Tübingen: Sustainable Development set in practice. *Sustainability*, 12(3), 861, p. 24. <https://doi.org/10.3390/su12030861>
- Siege, H., & Schreiber, J. R. (Eds.). (2016). *Education for sustainable development: Curriculum framework: A contribution to the global action program education for sustainable development* (2<sup>nd</sup> updated and extended edition). Cornelsen.
- UM BW—Ministerium für Umwelt, Klima und Energiewirtschaft Baden-Württemberg. (2020). *Nachhaltigkeitsstrategie Baden-Württemberg, Bilanz 2007 bis 2020* [Sustainability strategy Baden-Württemberg, taking stock 2007 to 2020]. [https://www.nachhaltigkeitsstrategie.de/fileadmin/Downloads/Publikationen/Strategie/N\\_-Berichte/Bilanz\\_2007-2020-N-Strategie\\_BF.pdf](https://www.nachhaltigkeitsstrategie.de/fileadmin/Downloads/Publikationen/Strategie/N_-Berichte/Bilanz_2007-2020-N-Strategie_BF.pdf)
- UNESCO. (2014). *UNESCO roadmap for implementing the global action program on education for sustainable development*. <https://sustainabledevelopment.un.org/content/documents/1674unescoroadmap.pdf>
- UNESCO. (2017). *Education for sustainable development goals: Learning objectives*. [https://www.unesco.de/sites/default/files/2018-08/unesco\\_education\\_for\\_sustainable\\_development\\_goals.pdf](https://www.unesco.de/sites/default/files/2018-08/unesco_education_for_sustainable_development_goals.pdf)
- UNESCO. (2020). *Education for sustainable development—A roadmap*. <https://unesdoc.unesco.org/ark:/48223/pf0000374802>.
- United Nations (UN). (2015). *Transforming our world: The 2030 agenda for sustainable development*. <https://sdgs.un.org/2030agenda>
- World Commission on Environment and Development (WCED). (1987). *Report of the world commission on environment and development: Our common future*. <https://sustainabledevelopment.un.org/content/documents/5987our-common-future.pdf>.

## Chapter 12

### Education for Sustainable Development (ESD) Classroom Practices: A South African Perspective

Caleb Mandikonza and Portia Kawai

*In this chapter, we explore how a South African teacher-training program prepares Natural Science and Life Sciences preservice teachers for ESD (Education for Sustainable Development). We illustrate how the notion of ESD evolved from that of Environmental Education (EE) and how that process is taken up into the university's teacher training system. Issues of sustainability, which mainly focused on the environment in its totality, have always been considered in South Africa, and EE was the driving educational imperative for understanding this relational process. However, the anthropocentric sustainability focus was not prominent. As a result of this focus, Environmental Education in South Africa led to a review of the curriculum in high school education, which subsequently meant that the teacher education curriculum had to take up EE to prepare teachers for the schools' EE. Following the 2005 promulgation of the Decade of Education for Sustainable Development (DESD), the notion of EE transformed into ESD, a more anthropocentric form of education that foregrounded sustainability and sustainable development. This study uses a qualitative case study in which data were collected through document analysis of course outline, as well as through semi-structured interviews with the lecturers for Natural Science and Life Sciences to pre-service teachers. The thematic patterns that emerged were used to analyze the data. The findings of the study provided an understanding of how preservice teachers were being prepared for ESD classroom practices. It was clear that the preparation of pre-service teachers for ESD was not explicitly planned for in most courses and would mostly emphasize environmentally related topics.*

<http://dx.doi.org/10.15496/publikation-76378>



*The study makes recommendations for a more systematic and explicit way of integrating ESD in Natural and Life Sciences teacher education classroom practices. To this end, ESD is found in school-level syllabi; therefore, Teacher Education needs to equip teachers with knowledge of ESD. This study showed that the mainstreaming of ESD is not in the guiding policies of the university but driven by the agency of individual lecturers. This insight is key, as it allows the comparison of ESD mainstreaming between the University of Witwatersrand and Tübingen University, the latter case being presented in another chapter.*

## **1 The South African sustainability context**

South Africa is part of the southern Africa sub-regional group of 15 tropical and subtropical countries, the Southern Africa Development Community (SADC), which lie south of the equator. The countries are characterized by many years of colonization and its consequent extractive resource economies. These years of devastating economic and political domination left a legacy of development challenges that manifest in poverty for the majority of the almost 360 million citizens (Ocheni & Nwanko, 2012). Almost 75% of the citizens live in rural areas, relying directly on environmental resources such as clean air, clean water, agriculturally productive soils, vegetation for timber and firewood, and associated ecosystem services. The strain on the environment results in social issues such as poverty and its associated social, economic, and political effects (Shackleton, 2014; SADC, 2020a). The remaining population, which is urban and progressively urbanizing, also has its own challenges, including unequal wealth and other physical, economic, and social issues. Southern Africa sees economic growth as the solution to these societal ills, which were caused by poor economic growth trajectories. Therefore, the need to balance economic growth through the bolstering of development activities becomes paramount for the whole SADC region (SADC, 2020b).

South Africa is the most economically powerful and most developed of the southern African states. This focus on economic growth development position also raises environment and development challenges for the same resources and people on which it is based. Issues of climate change, overexploitation, uncontrolled urbanization, unsustainable consumption patterns, poor waste management, and air and water pollution come to mind. Other issues include crime, poor transport, lack of clean water, unsafe and unhygienic food, food insecurity, and health issues for the majority (Brownlie, Walmsley & Tarr, 2016).

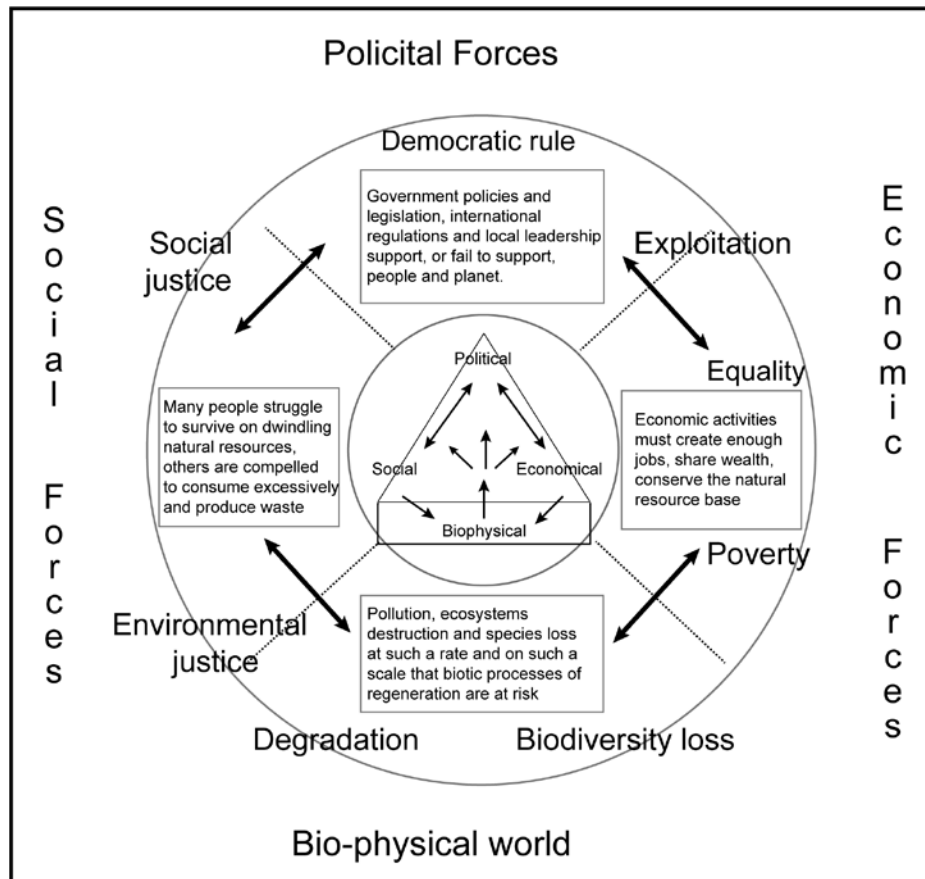

Figure 1 Interacting forces in the environment (O'Donogue, 2001 in UNEP, 2004, p. 20)

Furthermore, over 70% of the country's electricity comes from thermal power stations that are coal-fed. These power stations release huge quantities of carbon dioxide into the air annually, yet the country's need for electrical power continues to grow and the notion of alternative power sources, which must be sold to the nation through education, has not gained much momentum. All sustainability issues bedeviling the country are related to increased inequity and poverty across the country. Giddens (1999) saw development issues to be associated with risk, in that they pose a risk to well-being in the future. To this end, Beck (2000) noted development issues as being diverse, complex, and interacting in such a way that they cannot be solved by a single or straightforward solution. Such issues, according to Rittel and Webber (1973), are 'wicked problems'. A solution to one such problem tends to expose another problem. Engstrom and Saninno (2018) use a similar term, a 'runaway object' to denote these

everchanging and evolving problems. There is a need to develop the capacity to deal with these development concerns and risks, and education through teacher education is one possible solution.

To this end, South Africa sought to promote educational processes that help the nation redress this unsustainable condition through gaining an understanding of environment and development issues. Environmental education was envisaged as an educational response to these environment and sustainability challenges. The environment was constituted of interacting biophysical, economic, social, economic, and social aspects or forces, as shown in Figure 1 (O'Donoghue, 2001 in UNEP, 2004).

This implies that the manifestation of an environmental issue is an outcome of the above-mentioned aspects' interactions. To respond to any issue, it was important to establish the interacting factors in these aspects. The model points to the inseparability of environmental components and the nonlinear nature of responses in the development discourse. It further suggests that educational responses need to be more holistic, so that challenges are not considered in isolation from each other.

The environment model (O'Donoghue, 2001) seems to complement the Hattingh (2004) model for sustainable development well (see in Figure 2 below).

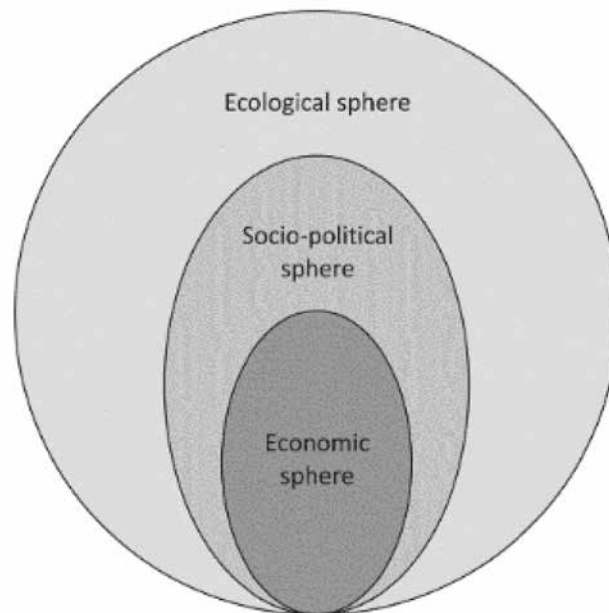

*Figure 2 Hattingh's view of sustainable development in terms of three embedded spheres (Hattingh, 2004, p. 161)*

Hattingh (2004) observed the dependence of sustainability on the physical environment in which development takes place. To this, Lotz-Sisitka et al. (2015) added that the economy, society, and environment are a nexus that cannot be treated in isolation. Sustainability, sustainable development interests and Education for Sustainable Development need to be inclusive and considerate of the intricate relationships between the component parts, avoiding piecemeal and quick-fix responses. This assertion tends to complicate the role of education in sustainable development and sustainability.

One of the sustainable development goals in this Anthropocene era is the building of a responsible and sustainable society, a society that has attained sustainability through a process called sustainable development. Sustainable development has been defined in many ways. Kopnina (2012) considers sustainable development as a context which depends on social, cultural, and environmental situations, and that in turn depends on societal behavior and responsibility. In a UN report, Brundtland (United Nations, 1987: 41) defines sustainability as “development that meets the needs of the present without compromising the ability of future generations to meet their own needs”. This definition does not explicitly mention the word *environment* but “needs” include the benefits of the natural environment. From the above definitions, sustainable development depends a lot on human behavior and responsibility.

South Africa sought to integrate environmental education into the schools' curriculum through the National Environmental Education Program for General Education and Training (NEEP-GET) since the body's establishment in 2005 (Schudel, le Roux, Lotz-Sisitka, Loubser, O'Donoghue & Shallcross, 2008). Furthermore, it produced resources and engaged capacity development for teachers in schools. It could not, however, make much inroad into teacher training. When Education for Sustainable Development (ESD) was taken up nationally in 2005, in line with the UNESCO Decade of Education for Sustainable Development (UNESCO, 2005), South Africa, as well as other SADC countries, noted Environmental Education as a vehicle and carrier for ESD (Lotz-Sisitka, 2006). Based on the framework shown in Figure 1, the need to expand the anthropocentric component to include more sustainability concerns was recognized. Teacher education still lacked support for ESD. In 2011, a national program called ‘Fundisa for Change’ was conceptualized to support preservice and in-service training in ESD.

The country does not have any education policies that speak directly to ESD, but some do speak to aspects of it. For example, the Minimum Requirements for Teacher Education Qualifications-MRTEQ (DHET, 2015) lays down the competences expected of beginner teachers and exit levels for the various qualifications but makes



little reference to education for sustainable development. Mainstreaming of ESD is therefore not policy driven. The lack of policy guidelines poses a challenge even for educators who have the capacity and agency to mainstream ESD, particularly in face of the need to build the capacity to achieve sustainable development through the 17 aspirational Sustainable Development Goals (SDGs) (UN, 2015). The United Nations Educational, Scientific and Cultural Organization (UNESCO) further converted the SDGs into Educational for Sustainable Development Goals Learning Objectives (ESDGs) for ease of use in education settings (UNESCO, 2017). Without policy guidelines, it is a mammoth task for teacher educators to implement the ESDGs as part of the classroom content.

To develop the knowledge, competences, and capabilities requisite for a sustainable future, educators should engage learners' cognitive, socio-emotional and behavioral domains through ESD pedagogy. Educators promote ESD through pedagogical approaches focused on learner-centered, action-oriented, and transformative learning. These approaches depend on the principles of ESD, which include pedagogies that promote multidisciplinary learning, that is, learning in which several disciplines are engaged, as well as multidimensional learning, which considers contextual ways of thinking while bringing together complex adaptive systems to innovate (Eilam & Trop, 2010). Pedagogies need to include emotional learning, which includes clarifying values and ethical considerations.

This chapter therefore aims to show how ESD is represented in the South African teacher education curricular documents, how it manifests in classroom practices, and in what conditions it is implemented. We will use the term program to signify the four years of study towards a degree. We will also refer to the course as a specific subject that students engage in over time, such as a semester or a year. Within the course are topic-specific or subject-specific modules. The Natural Sciences course is taught over a year and is constituted of the Life Sciences and Physical Sciences modules. Life Sciences (Biology) courses are organized into topic modules. University teaching is guided by outlines of the courses, which according to Archer (1995) constitute the structure of the planned topics of modules and which Mahon, Francisco and Kemmis (2017) describe as practice architectures that frame academic practice at the course level. Modules for content and for pedagogy or teaching methods generally go together.

This qualitative case study intended to address the research question: how does a South African teacher-training program prepare Natural Science and Life Sciences preservice teachers for ESD?

## 2 Research design

An interpretative, qualitative case study research design was used to develop this study. This design was appropriate because it offered the study flexibility to deduce meanings in the phenomenon of ESD classroom practice, based on the researchers' understanding of education for sustainable development in the institutional context (Yin, 1984; 2014). This was a case of ESD classroom practice in a specific teacher training context and within a specific discipline of Life Sciences (III and IV), which is a component of Natural Sciences (I and II) (Creswell et al., 2007). Although document analysis was used to establish if the course outlines referred to ESD, semi-structured interviews were the main source of data. The interviews were structured to inquire into lecturers' understanding of ESD; whether it was part of their institutional mandate to implement ESD; why they thought ESD was relevant for the science curriculum; how they were mainstreaming it into their practice; and what successes and challenges they were encountering when mainstreaming ESD. Use of the case study method permitted making conclusions of the study to the Life Sciences sub-discipline (including Life Science III and IV), rather than generalizing the whole of Natural Sciences I and II.

Data collection was conducted through the document analysis of course outlines and through semi-structured interviews with lecturers who teach the Life Sciences component of Natural Sciences I and II, as well as Life Sciences III and IV modules. Each of the courses has a course outline, meaning that four course outlines were analyzed deductively to establish whether ESD was present and presented in the document through content, pedagogy and assessment. Key features of ESD included the development of sustainability knowledge with understanding, sustainability skills, sustainability values and actions or practices for creating a more sustainable world, contributing to a more sustainable world, promoting environmental protection and conservation, promoting social equity, and promoting conditions that encourage economic sustainability. The four content course outlines (NSI, NSII, LSIII and LSIV) as well as three methods courses (Methodology for NSI, NSII and LSIII) were analyzed deductively using key features of ESD. The program does not have Methodology for LSIV. Five Life Sciences lecturers share parts of the content and methods course outlines. Therefore, a total of five semi-structured interviewees were conducted with lecturers. Semi-structured and audio-recorded interviews were conducted with the Life Sciences lecturers to investigate how they mainstreamed ESD in their teaching and what influenced their ESD practice.

Data were analyzed qualitatively and inductively; the analytical process was guided by the definition and characteristics of ESD presented earlier in this chapter.

### 3 Results

ESD in guiding curriculum documents: All Natural Sciences (I and II) and Life Sciences (II and IV) course outlines for both the content and methods point to the paucity of explicit ESD. Course outlines are generic when it comes to the teaching of scientific content. The Life Sciences modules of Natural Sciences course outlines

*“... include cell biology and biodiversity in order to build understanding of life processes, conservation, variety and classification of common life forms, adaptation to habitat and the environment. Students will also study interactions that occur in nature between living organisms and their environment, and the terminology and concepts that describe them.”* (Wits School of Education, 2021a)

The Life Sciences content course outlines aim

*“... to help students to acquire knowledge, develop skills and competencies, and to develop positive attitudes towards science, towards the living world in particular and towards the teaching and learning of Life Sciences.”* (Wits School of Education, 2021b; 2021c)

Both course outlines do not explicitly refer to the development of competences for ESD, but to traditional content. There is nothing in these documents which compels the educator to teach ESD. However, the Methods Course outlines propose the development of preservice teachers' professional knowledge through their intimate engagement with the Pedagogical Content Knowledge (PCK) framework (Shulman, 1986). This framework does not reflect ESD but is the closest that an educator can use to develop ESD competences in preservice Life Sciences and Natural Sciences courses through pedagogical initiatives. However, this gap is worrisome, since some of the primary schools' and high schools' subjects' curriculum documents have explicit ESD content. Although the case study did not empirically establish links in content between ESD in teacher education and the teachers' practice, there is a gap between curricular experiences in PCK for Natural Sciences during teacher development and ESD competence demands in the schools' curriculum documents. Teacher education lacks the ability to develop competences for teaching ESD; ultimately, the teacher graduate will not have adequate PCK for teaching ESD in the school's curriculum. Such a view undermines the possibility of the role that the SDG 4 plays on Quality Education and especially Target 4.7 as the basis for the achievement of all the other 16

SDGs (United Nations, 2015). Target 4.7 is the backbone for ESD, so its absence in the teacher education curriculum points to poor development of ESD at all levels of formal education. The lack of guidelines for mainstreaming ESD and developing ESD competences among teacher educators hinders them from contributing to the achievement of sustainable development goals through teacher education for a country that has development challenges.

#### 4 ESD in classroom practice

Despite the lack of supporting guidelines in course outlines, there are isolated cases of lecturers who teach ESD content within the current Life Sciences and Natural Sciences modules. However, the integration of ESD in their classrooms is more due to the self-initiative and passion of those specific individuals. Lecturers who have attended capacity development on their own or have been involved in the ESD collaborative research projects mentioned individually and independently explored mainstreaming ESD in their classroom practice. Their teaching depends on individual capabilities and agency for teaching that develops ESD competences. Since these explorations are not guided by any clear university policy, they are individually motivated by the desire to develop competences for ESD and the sustainable development goals. These lecturers expressed that even though the course outlines cover traditional biological content, they view the same content as social-ecological. The course outline for Life Sciences ends with suggesting that students would be expected “...to develop positive attitudes towards science, towards the living world in particular...” (Wits School of Education, 2021b; 2021c). They interpret the positive attitudes towards the living world as having an implicit intent for mainstreaming ESD and the development of ESD competences. To this end, a lecturer noted that:

*“Life Sciences content is connected to ESD because life forms exist within a finite biophysical space. One cannot teach the content without extending to show how the organisms impact and are impacted by their relationships in the living space.”*

The content they teach remains within the limits of the finite ecological space. Therefore, they recognize that the content influences and is influenced by human interactions. Their view is influenced by the Hattingh (2004) framework, in which human endeavors are dependent on the natural environment and natural systems. Although this perspective depends on the lecturer's capabilities and agency for developing ESD

competences, it shows that PCK for ESD is implicit within some of the existing content. However, lecturers bemoaned the lack of time to adequately address the sustainability content within the confines of the course outlines, since the modules are structured to accommodate traditional content. To make ESD mainstreaming and teaching more widespread among the lecturers, it must be made explicit in the curriculum documents.

It has been difficult to distinguish what constitutes ESD-aligned pedagogy. Ultimately, lecturers tend to be guided into ESD-aligned methods by other concepts that are not unique to ESD, such as Vygotsky (1978)'s sociocultural learning. Even though lecturers may not consciously engage with ESD teaching and learning methods and assessments, they conduct these for other reasons. One lecturer remarked:

*"I use collaborative learning because I believe in Vygotsky, in that I am a knowledgeable other whose role is facilitator of learning, rather than giver of knowledge."*

The lecturer therefore presented one key aspect of ESD pedagogy through learner-centered facilitation of learning, even though there was no reference to the development of ESD competences.

The lecturer further recognized that:

*"...students are not blank slates; they bring a wealth of knowledge, and personal and social lived experiences from their backgrounds. I make effort to tap into that knowledge in order to scaffold new knowledge."*

The lecturer bases their teaching on sociocultural approaches. This is already one of the ESD approaches. However, most of the concepts that are scaffolded are traditional biology concepts. One lecturer expressed his desire to engage transformative pedagogies:

*"I keep exploring working with transformative pedagogies. However, the challenge is that the pedagogies would best be conducted together with relevant ESD content, which the curriculum does not allow. The module ends before I can make any meaningful observations on what could have transformed in learner agency."*

Individual capability and agency in this individual's practice are therefore limited by the structural constraints. Furthermore, the observation emphasizes that ESD content and practice cannot be separated if agency is to become apparent in transforma-

tive learning pursuits. Therefore, PCK for ESD is likely to make sense if relevant content and appropriate methods are integrated. Although course outlines are open to interpretation, time constraints limit the agency of the lecturers, who must teach the traditional content and the teaching methods separately. Approaches to ESD must integrate content and methods.

## 5 Opportunities for ESD classroom practices

It should be noted that the integration of ESD in teacher-education curricular practices is more implicit than explicit and depended on teacher-educators' agency, personal interest and inclination towards ESD. Such a condition has been made possible by the existence of lecturers who are passionate about the idea of ESD. Some consider it essential to the work that they do, seeing it as the organizing framework for their teacher education practice, which includes developing appropriate pedagogical content knowledge and practice. Each school subject in the curricula has a unique part to play in the integration of education for sustainable development. Science subjects such as Biology are strategically positioned to deal with some of the UN Sustainable Development Goals, based on the overlap of content and social aspects (Fien, Maclean & Park, 2009). The integration of ESD must be explicitly planned and implemented in all subjects, including Biology. In the same view, each topic can contribute to ESD in its unique way if the lecturer is knowledgeable of ESD and Sustainable Development Goals. In another sense, teaching for Education for Sustainable Development Goals (ESDGs) Learning Objectives can be starting point for teaching ESD. In another sense, teaching for Education for Sustainable Development Goals (ESDGs) Learning Objectives can be starting point for teaching ESD. Being UNESCO's translation of SDGs into the education sector, ESDGs provide educators with a launchpad for responding to SD in the classroom. Each ESDG is organized into three learning objectives: cognitive, socio-emotional and behavioral. These objectives already guide the educator in their planning, where they should seek to develop foundational or content knowledge, teach to influence the affective domain, while also helping the learner to develop their ability to take action.

One of the Sustainable Development Goals (SDG no. 4) emphasizes the importance of inclusive and equitable quality education with improved life-long learning opportunities (United Nations, 2018). It is important to have preservice teachers prepared to ensure that Biology education encapsulates the values of inclusivity and equitable access, in addition to providing learners with life-long learning opportunities through ESD.

Some studies on the integration of sustainable development into science teaching use environmental education as an entry point for their PCK, which is what the SA curricula introduced before the advent of ESD as part of the initial ESD integration. Environmental education served as a vehicle for mainstreaming ESD, based on the O'Donoghue (2001) model presented earlier. This was in view of the model that sees the environment as being composed of political, social, economic and biophysical aspects. The assumption was that environmental education focuses on the inculcation of behaviors, values and practices for the sustainability of life on planet earth (Stanisic & Maksic, 2014; Schild, 2016). The uptake of ESD, which foregrounds sustainability, has gained slow momentum, mainly because the idea has not received any impetus from institutional policy. The environment is one of the major pillars for sustainability in addition to the social and economic pillars (Burmeister, Rauch & Eilks, 2012). Abdullah, Halim and Shahali (2011) observe that in the Malaysian context, Biology was more amenable to the integration of environmental education than the other science subjects, Chemistry and Physics. This trend is also evident in South Africa, where Physics and Chemistry teachers struggle with mainstreaming ESD into their curricular practice. Even though the environment pillar is important when considering sustainability issues in classroom practices, more holistic approaches to implementing ESD through various courses/modules should be explored. This will broaden the integration of ESD in teacher education, in schools and in society.

## 6 Challenges in integration of ESD classroom practices

Teacher education curricula lack policy guidelines on Education for Sustainable Development. If there were a policy guideline, it would encourage all lecturers to consider mainstreaming ESD in their curriculum practice. To this end, training programs for Biology pre-service teachers must adjust to the sustainable development imperatives on the policy level so that they can build capacity in the pre-service teachers, who will in turn integrate ESD in their classroom practices. Institutional leadership at the school and faculty levels needs to promote and facilitate capacity development for ESD, which in turn may lead to the transformation of mindsets and of teacher education practice.

Teacher educators showed a lack of preparedness for ESD starting with lack of knowledge of the concept and consequently ideas of how to mainstream it in their curricular practice. There is a need for more concerted effort to develop capacity for mainstreaming ESD. South Africa has started that process through the 'Fundisa for Change'

(Teach for Change) program, which develops teacher educators' capacity to mainstream ESD. However, the program lacks funding to scale up and reach out to more higher education contexts at a time. Even though ESD can be used as an entry point, capacity for this process is still wanting in the South African context, where some teacher educators do not know about the SDGs. Another program sponsored by UNESCO for Southern African Development Community (SADC) teacher educators is Sustainability Starts with Teachers (SST), which also instils ESD integration in practicing teachers and teacher educators for various subjects, as well as guiding them in the ESD Change Projects they implement in their schools. Some of the SDGs exist as topics in Biology, but it is not very clear to the teachers how they can present them in relation to sustainability issues; hence the need to have it clearly outlined so that ESD is included in all topics and in subjects across the curricula. However, the teaching of the topics may not translate to the teaching of ESD and the attainment of the set SDGs. This was confirmed by Grimm (2008), who observed that some practices in education have contributed to the current sustainability challenges.

The implication is that Biology should be taught for sustainable development, and that the existence of common topics between the subject and the SDGs serves as an enabling springboard for implementation. The university has some teacher educators involved in the 'Fundisa for Change' and the SST programs. A few teacher educators are invited to participate per intake, since both programs have limited capacity and can only take a few candidates from each South African university. The last intake could accommodate more participants, since it was online due to COVID-19 restrictions. Such programs are essential initiatives, especially since issues of ESD are urgent in this Anthropocene, but the spread of ESD knowledge to other parts of the country is very slow.

One of the challenges we observed is that the preparation of Biology preservice teachers for ESD is more biased towards environmental education, whereas the other pillars for sustainability—the economic, social and citizen skills and the pedagogies pillar—tend to be under-represented. Furthermore, the way these are dealt with tends to depend on the topic and the agency of the teacher-educator. This becomes a challenge in terms of the prospective teachers' preparedness to then integrate ESD in their classroom practices. Inasmuch as ESDGs' learning objectives could assist, the challenge is that teachers are clearly informed as to how they can present them in relation to sustainability issues aligned with the content they will be teaching.

Another challenge is that the teacher-educators do not acknowledge the feasibility of integrating ESD in every topic. This shows that they are not acknowledging the other pillars of sustainability and the other Sustainable Development Goals (SDGs).



## 7 Conclusion

Although the discourses of sustainable development and ESD have been prominent on the international level, they have failed to stimulate the desired responses in terms of teacher development. ESD is either implicit or wholly absent from curriculum documents on an institutional as well as course level, including preservice teacher education in Natural Sciences and Life Sciences. This lack of guidelines makes the mainstreaming of ESD and the development of ESD competences into a voluntary enterprise for concerned teacher educators, whose practices are also limited by inadequate time allocation for the respective modules, considering that the integration of ESD was not taken into consideration when allocating time to the teaching and learning of the respective modules. The University of Witwatersrand's School of Education has not yet developed any ESD strategy or ESD standards that would ensure that educators have an enabling environment, adequate capacity and PCK for developing ESD competencies. If preservice teacher education must contribute more to the achievement of SDGs, there is a need for more concerted effort in ensuring that policy documents address ESD explicitly. The explicit nature of ESD in policy will constitute Archer's structure (1995), which will iteratively guide culture and agency. However, having a few lecturers demonstrating that ESD competences can be developed is crucial, since there are already a few lecturers who are investing their efforts in this direction.

Lecturers use a variety of pedagogical approaches as guided by the PCK framework: knowing one's learners, relevant presentations and knowing one's content. The PCK framework offers the potential to develop ESD competences by transforming content through appropriate pedagogy. However, this potential can only be harnessed better if lecturers receive the capacity to mainstream ESD, which is currently found only in isolated cases. The lecturers who show ESD-aligned pedagogy noted that it should be easier for preservice teachers to develop ESD competences further if lecturers receive more capacity, but that enhanced capacity could be more meaningful if course outlines accommodated ESD content.

### Literature

Abdullah, S. I. S. S., Halim, L., & Shahali, E. H. M. (2011). Integration of environmental knowledge across biology, physics and chemistry subjects at secondary school level in Malaysia. *Procedia—Social and Behavioural Sciences*, 15, 1024–1028.

Archer, M. S. (1995). *Realist social theory: The morphogenetic approach*. Cambridge University Press.

Beck, U. (2000). *World risk society*. Polity Press and Blackwell Publishers.

- Creswell, J., W., Hanson, W., E., Plano, C., Vicki L., & Morales, A. (2007). Qualitative research designs: Selection and implementation. *The Counseling Psychologist*, 35(2), 236–264. <https://doi.org/10.1177%2F0011000006287390>
- Giddens, A. (1999). *Runaway world: How globalisation is reshaping our lives*. Profile Books.
- Brownlie, S., Walmsley, B., & Tarr, P. (2006). Guidance document on biodiversity, impact assessment and decision making in Southern Africa as part of IAlA's capacity building in biodiversity and impact assessment project.
- Burmeister, M., Rauch, F., & Eilks, I. (2012). Education for sustainable development (ESD) and chemistry education. *Chemistry Education Research and Practice*, 13, 59–68.
- Department of Higher Education and Technology (2015). *Minimum requirements for teacher education qualifications*. South Africa.
- Eilam, E., & Trop, T. (2010). ESD pedagogy: A guide for the perplexed. *Journal of Environmental Education*, 42(1), 43–64. <https://doi.org/10.1080/00958961003674665>
- Engestrom, Y., & Saninno, A. (2018). Cultural-historical activity theory: Founding insights and new challenges. *Cultural-Historical Psychology*, 14(3), 43–56. [https://psyjournals.ru/en/kip/2018/n3/Sannino\\_Engestrom.shtml](https://psyjournals.ru/en/kip/2018/n3/Sannino_Engestrom.shtml)
- Fien, J., Maclean, R., & Park, M. G. (2009). *Work, learning and sustainable development: Opportunities and challenges*. Springer.
- Hattingh, J. (2004). Speaking of sustainable development values... a response to Alistair Chadwick's viewpoint responding to destructive interpersonal interactions: A way forward for school-based environmental educators. *Southern African Journal of Environmental Education*, 21, 154–165.
- Kopnina, H. (2012). Education for Sustainable Development (ESD): The turn away from 'environment' in environmental education? *Environmental Education Research*, 18, 699–717.
- Lotz-Sisitka, H. (2006). *Positioning education for sustainable development in southern Africa*. Howick: SADC Regional Environmental Education Program, Share-Net.
- Lotz-Sisitka, H., Wals, A. E. J., Kronlid, D., & McGarry, G. (2015). Transformative, transgressive social learning: Rethinking higher education pedagogy in times of systemic global dysfunction. *Current Opinion in Environmental Sustainability*, 16, 73–80. <https://doi.org/10.1016/j.cosust.2015.07.018>
- Mahon, K., Francisco, S., & Kemmis, S. (2017). *Exploring education and professional practice: Through the lens of practice architectures*. Springer Science.
- Ocheni, S., & Nwankwo, B., C. (2012). Analysis of colonialism and its impact in Africa. *Cross-Cultural Communication*, 8(3), 46–54. <http://dx.doi.org/10.3968/j.ccc.1923670020120803.1189>
- Rittel, H. W. J., & Webber, M. M. (1973). Dilemmas in a general theory of planning author(s). *Policy Sciences*, 4(2), 155–169. <http://www.jstor.org/stable/4531523> [09.02.2011].
- Shackleton, C., M. (2004). *Assessment of the livelihoods importance of forestry, forests and forest products in South Africa*. [https://www.dffe.gov.za/sites/default/files/reports/livehoodsimportance\\_forestproducts.pdf](https://www.dffe.gov.za/sites/default/files/reports/livehoodsimportance_forestproducts.pdf)
- Southern African Development Community (2020a). *SADC demographics and social statistics, 2019*. [https://www.sadc.int/files/4816/1279/0669/SADC\\_SYB\\_2019\\_Print\\_version\\_V1.0.pdf](https://www.sadc.int/files/4816/1279/0669/SADC_SYB_2019_Print_version_V1.0.pdf)
- Southern African Development Community (2020b). *Southern African Development Community (SADC) Vision 2050*. Gaborone, Botswana.
- Schudel, I., le Roux, C., Lotz-Sisitka, H., Loubser, C., O'Donoghue, R., & Shallcross, T. (2008). Contextualising learning in advanced certificate in education (Environmental Education) courses: synthesising contexts and experiences. *South African Journal of Education*. *EASA*, 28, 543–559.
- Shulman, L. (1986). Those who understand: Knowledge growth in teaching. *Educational Researcher*, 15(2), 4–14.
- Stanisic, J., & Maksic, S. (2014). Environmental education in Serbian primary schools: Challenges and changes in curriculum pedagogy and teacher training. *Journal of Environmental Education*, 45(2), 118–131.
- UNEP (2004). *Module 1: Environment, sustainable development and the university in Africa*. <http://www.unep.org/training/downloads/toolkit/4.0%20-%20Module%201.pdf> [15.07.2021].
- UNESCO (2005). *United Nations decade of education for sustainable development: International implementation scheme*. <http://unesdoc.unesco.org/images/0014/001486/148654e.pdf> [16.02.2012].
- UNESCO (2017). *Education for sustainable development goals (ESDGs) learning objectives*. UNESCO.

- United Nations (1987). *Report of the world commission on environment and development: Our common future (the Brundtland report)*. <https://sustainabledevelopment.un.org/content/documents/5987our-common-future.pdf>.
- United Nations (2015). *Transforming our world: The 2030 agenda for sustainable development*. <https://sdgs.un.org/goals>.
- United Nations (2018). *The sustainable development goals report 2018*. United Nations Publications.
- Vygotsky, L. S. (1978). *Mind in society: The development of higher psychological processes*. M. Cole, V. John-Steiner, S. Scribner & E. Souberman (Eds.). Harvard University Press.
- Wits School of Education, (2021a). *Natural sciences I course outline*. University of Witwatersrand.
- Wits School of Education, (2021b). *Life sciences III course outline*. University of Witwatersrand.
- Wits School of Education, (2021c). *Life sciences IV course outline*. University of Witwatersrand.
- Yin, R. K. (1984). *Case study research: Design and methods*. Sage Publications.
- Yin, R. K. (2014). *Case study research: Design and methods*. Sage Publications.

## Authors' information



**Prof. Dr. Karin Amos** is professor of educational science with a focus on international comparative education and (inter-) cultural education at the Institute of Education. She is vice president for academic affairs at the University of Tübingen (karin.amos@uni-tuebingen.de).

**Dr. Douglas Andrews** is a research associate and postdoc at the Wits School of Education, Faculty of Humanities, University of the Witwatersrand. He is a school principal and a member of the UNESCO Chair in Teacher Education for Diversity and Development and (douglas.andrews@wits.ac.za)

**Jonas Bischof** was an assistant at the chair of education with a focus on inclusion, heterogeneity and diversity. He completed a master's degree in educational science from the University of Tübingen (jonas.bischof@uni-tuebingen.de).

**Prof. Dr. Thorsten Bohl** is professor of educational science with a focus on school pedagogy at the Institute of Education and Director of the Tübingen School of Education at the University of Tübingen (leitung@tuese.uni-tuebingen.de).

**Matthias Bornemann** is a coordinator of the Competence Center for Sustainable Development and of the platform Global Encounters at the University of Tübingen (matthias.bornemann@uni-tuebingen.de).

**Prof. Dr. John Bradley** is honorary professor with a focus on chemistry education in the division of science education at the Wits School of Education, University of the Witwatersrand (john.bradley@wits.ac.za).

**Prof. Dr. Taiga Brahm** is professor of economic education at the faculty of economics and social sciences at the University of Tübingen (taiga.brahm@uni-tuebingen.de).

**Jun.-Prof. Dr. Jan-Philipp Burde** is professor of physics education and vice-dean of academic affairs for teaching degree courses of physics and astronomy at the University of Tübingen (jan-philipp.burde@uni-tuebingen.de).

**Deborah Diekmann** is a researcher and coordinator in the area of internationalization at the Tübingen School of Education, University of Tübingen (deborah.diekmann@uni-tuebingen.de).

**Dr. Reuben Dlamini** is a senior lecturer in educational information and engineering technology at the Wits School of Education, University of the Witwatersrand (Reuben.Dlamini@wits.ac.za).

**Prof. Dr. Marcus Emmerich** is professor of education with a focus on inclusion, heterogeneity and diversity at the Tübingen School of Education and director of the Institute of Education at the University of Tübingen (marcus.emmerich@uni-tuebingen.de).

**Tamara Falcone** is a student of philosophy and Middle Eastern studies and student assistant in the area of internationalization at the Tübingen School of Education, University of Tübingen (tamara.falcone@student.uni-tuebingen.de).

**Dr. Felician Führer** is an educational researcher and project coordinator with a focus on the teaching profession at the Tübingen School of Education, University of Tübingen (felician.fuehrer@tuese.uni-tuebingen.de).

**Dr. Diana Grundmann** is a researcher with a focus on education for sustainable development and coordinator of the Competence Center for Sustainable Development at the University of Tübingen (diana.grundmann@uni-tuebingen.de).

**Elisabeth Hofmann** is a researcher and coordinator in the area of internationalization at the Tübingen School of Education, University of Tübingen (elisabeth.hofmann@uni-tuebingen.de).

<http://dx.doi.org/10.15496/publikation-76377>



**Dr. Portia Kawai** is lecturer of life sciences (biology) education with a focus on curriculum instructional design and development at the Wits School of Education, University of the Witwatersrand (portia.kawai@wits.ac.za).

**Dr. Caleb Mandikonza** is lecturer of life sciences (biology) education at the Marang Centre for Mathematics and Science Education at the Wits School of Education, University of the Witwatersrand (caleb.mandikonza@wits.ac.za).

**Prof. Dr. Felix Maringe** is professor of higher education, editor in chief of the Journal of Education, former Head of the Wits School of Education and currently deputy vice chancellor at University of Kigali (felix.maringe@wits.ac.za).

**Prof. Dr. Elizabeth Mavhunga** is professor of science education (chemistry) at the Wits School of Education and the chair of the Research Capacity Building Committee of SAARMSTE (elizabeth.mavhunga@wits.ac.za).

**Peter Moodie** is a visiting lecturer in science education and teacher education at the Setlhare Science Curriculum Trust, RADMASTE Centre, Wits School of Education at the University of the Witwatersrand (peter.moodie@wits.ac.za).

**Dr. Emmanuel Mushayikwa** is a senior lecturer in physics education with a focus on the self-directed professional development of STEM teachers and the integration of science and Indigenous Knowledge Systems (IKS) in the science classroom at the Wits School of Education, University of the Witwatersrand (emmanuel.mushayikwa@wits.ac.za).

**Ngonidzashe Mushaikwa** is a research assistant at the University of the Witwatersrand (ngonic68@hotmail.com)

**Prof. Dr. Eunice Nyamupangedengu** is associate professor in science education and director of Marang Centre for Mathematics and Science Education at the University of the Witwatersrand (eunice.nyamupangedengu@wits.ac.za).

**Dr. Emmanuel Ojo** is a senior lecturer of social and economic sciences with a research focus on higher education, sustainability and interdisciplinary studies at the Wits School of Education, University of the Witwatersrand (emmanuel.ojo@wits.ac.za).

**Prof. Dr. Ruksana Osman** is professor of education in the field of teacher education and higher education at the Wits School of Education and Senior Deputy Vice-Chancellor of Academic at the University of the Witwatersrand. She holds the UNESCO Chair in Teacher Education for Diversity and Development and is an elected member of the Academy of Science of South Africa (ruksana.osman@wits.ac.za).

**Prof. Dr. Thomas Potthast** holds the chair of ethics, philosophy, and history of the life sciences and is director of the International Center for Ethics in the Sciences and Humanities, and of the Competence Centre for Sustainable Development at the University of Tübingen (potthast@uni-tuebingen.de).

**Prof. Dr. Christoph Randler** is professor for didactics in biology at the Faculty of Science at the University of Tübingen (christoph.randler@uni-tuebingen.de).

**The volume presents international collaborative and comparative approaches in teacher education, addressing researchers, teachers, and other educational professionals who are interested in the following topics:**

- ▶ Binational research perspectives on teacher education in South Africa and Germany
- ▶ Inclusion and educational equity
- ▶ Professionalization and mentoring
- ▶ Curricular characteristics and pedagogical content knowledge in education in economics, biology, and physical chemistry
- ▶ Education for sustainable development as a growing cross-sectional topic

The results shed light on similarities and on different challenges experienced within the South African and the German educational, historical, socio-political, and institutional contexts. They reveal the struggles towards the best possible preparation of future teachers, and introduce the Wits School of Education and the Tübingen School of Education as players who consistently and energetically advance teacher education, based on research, relevance, and responsibility.

Successful international collaboration has the ability to generate new impulses, increase global awareness of whole institutions, and open horizons for mutual understanding in academia. Wits School of Education and Tübingen School of Education are thankful for the support from the German Academic Exchange Service (DAAD), from the excellency funding of the University of Tübingen, and from the Global South Center, University of Tübingen.

**Elisabeth Hofmann** has led the area of internationalization at Tübingen School of Education from 2016 to 2022.

**Elizabeth Mavhunga** is a professor of science education (Chemistry) at the Wits School of Education, and the chair of the Research Capacity Building Committee of SAARMSTE.

**Thorsten Bohl** is a professor of educational science and director of the Tübingen School of Education.

**Felix Maringe** is a professor of higher education, former head of the Wits School of Education and currently deputy vice chancellor at the University of Kigali.

**Deborah Diekmann** is leading the area of internationalization at Tübingen School of Education since 2023.



9783947251704

SCHRIFTENREIHE  
DER TÜBINGEN  
SCHOOL OF EDUCATION

HERAUSGEGEBEN VON  
THORSTEN BOHL,  
NINA BECK,  
SIBYLLE MEISSNER

TÜBINGEN  
UNIVERSITY  
PRESS 